

MODEL: 1350-RVB
1350 LB. ROLLING MOBILE VEHICLE STEEL BARRIER

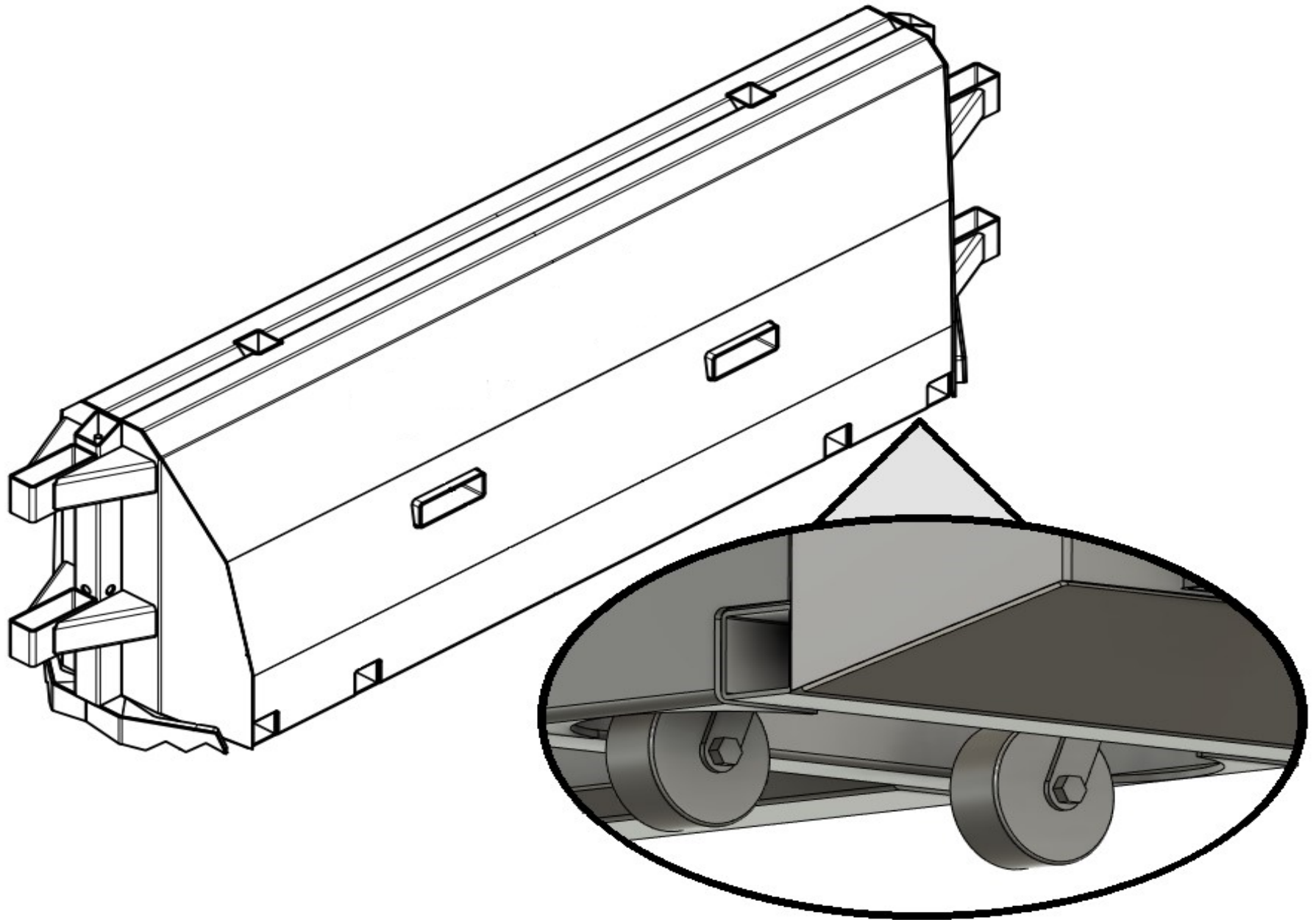

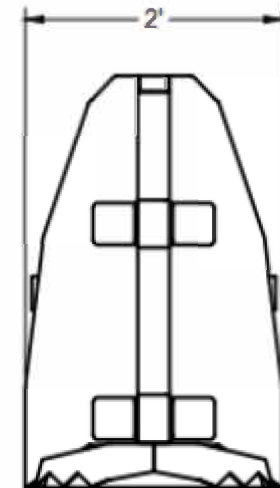
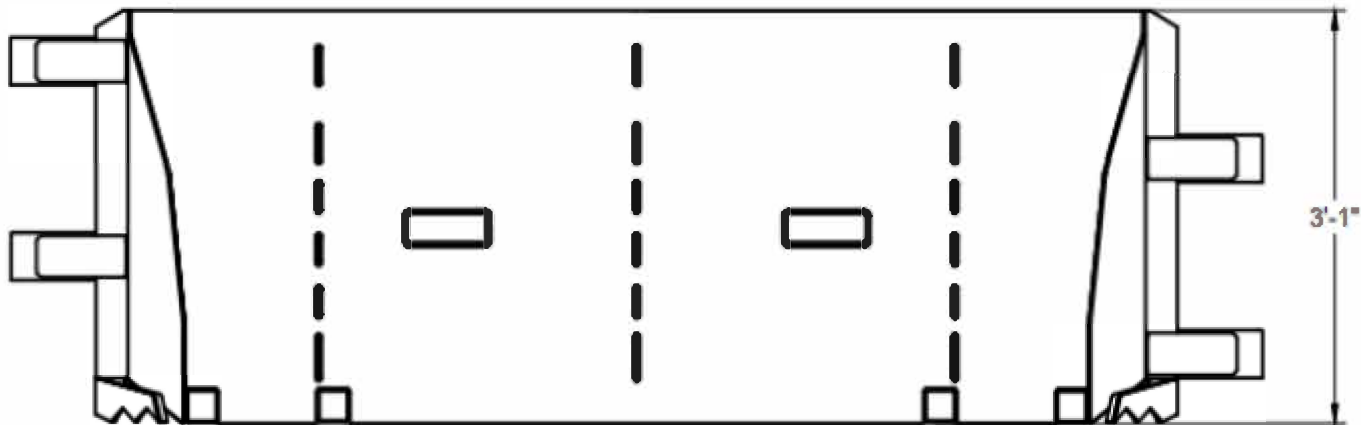

100% STEEL - 1/4" REINFORCED TUBING AND RIBS - HOT DIPPED GALVENIZED

Designed for Safe, Fast, Easy Barrier Deployment

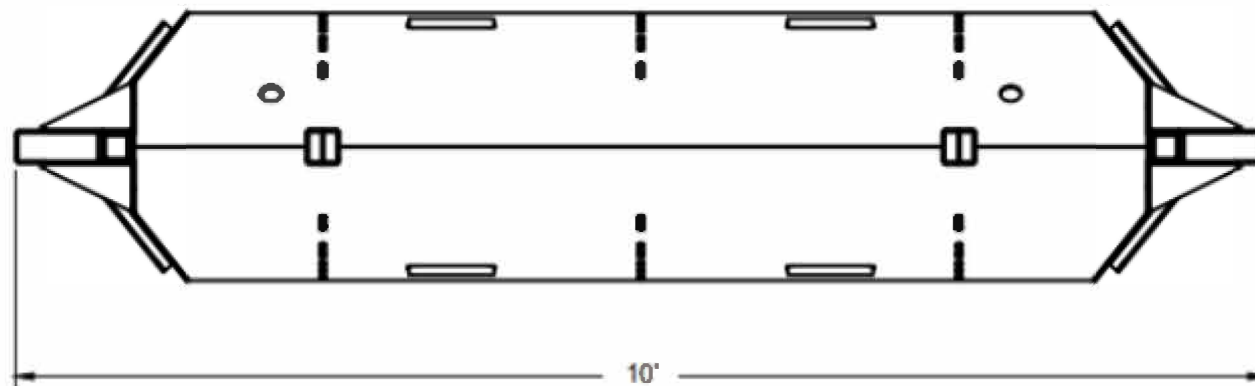

TRAILER SPECIFICATIONS:

Max Load Capacity: 12,000 LB

Max Barrier Capacity: 6

Max Barrier Weight: 9,000 LB

Load Angle: 3 Degrees

BARRIER SPECIFICATIONS: 1350 LBS

Length: 10' Bottom Width: 2'

Height: 3' 1" Top Width: 7"

Deployable wheels, spiked claws, tow bar, and barrier linking system. Two person transport, deploy and take-down. Industry leading affordability per linear foot.

