

EKKO[®]

MATERIAL HANDLING EQUIPMENT

MOVING AHEAD

3-WHEEL ELECTRIC FORKLIFT EK15A SERIES

- Load Capacity 3300 lbs.
- Lift Height 177 in. 3 Stage
- Side Shifting Forks
- Free Lift 59"
- EPS (Elec. Power Steer)
- Length 106.6 in.
- Curtis Controller
- Tilt 2/5 degree
- Mast Height 79.6 in.
- Overhead Guard 77 in.
- Batteries & Charger
- 3 Year Limited Warranty



EK15A

Superior quality, maneuverable, compact, and durable for all your material handling applications. Ideal for small aisles and areas.

WEIGHT CAPACITY: 3300 lbs. @ 24" load center

LIFT HEIGHT: 177" (14.75 ft) 3 Stage

SIDE SHIFTING FORKS: 45.3"

MAST HEIGHT: 79.6"

TURNING RADIUS: 53

FREE LIFT: 59"

TILT: 2/5 degree

INTEGRAL BATTERY / CHARGER: 24V 400AH, 24-volt Industrial batteries with external direct connect 110A 110VAC plug-in automatic 24V/50A charger (both Included)

BRAKING: Drum brakes

SPEED TRAVEL: 6.21 mph empty ; 5 mph loaded

LIFTING SPEED: 5.5 ips empty; 4 ips loaded

LOWERING SPEED: 4.7 ips empty; 5.3 ips loaded

DRIVE WHEELS: 9.8" x 5" cushion

LOAD WHEELS: (2) 12" x 5" cushion

HYDRAULICS LIFTING MOTOR: 24V 2500 Watt lifting motor with hardened chrome moly steel for durability.

DRIVE MOTOR: 24V 2000 Watt AC drive motor for efficiency and high torque.

AC CONTROLLER: 24V Curtis provides performance through entire range of speed; Constant travel speed regardless of load; Battery discharge indicator combination gauge.

BRAKES: Drum Brakes with Electro-magnetic braking for secure stopping power; Electronic neutral braking for accurate control.

LIGHTING: LED Head lights and Brake lights.

OPERATOR CONTROLS: EPS (Electric Power Steering), tilt lifting, lowering, side shifting forks, horn functions are located in the ergonomic sit down; Led lighting.

CHASSIS AND MAST: Robotic Welding; Heavy duty steel chassis with I-beam mast for durability; Telescoping mast.



3-Wheel Electric Forklift

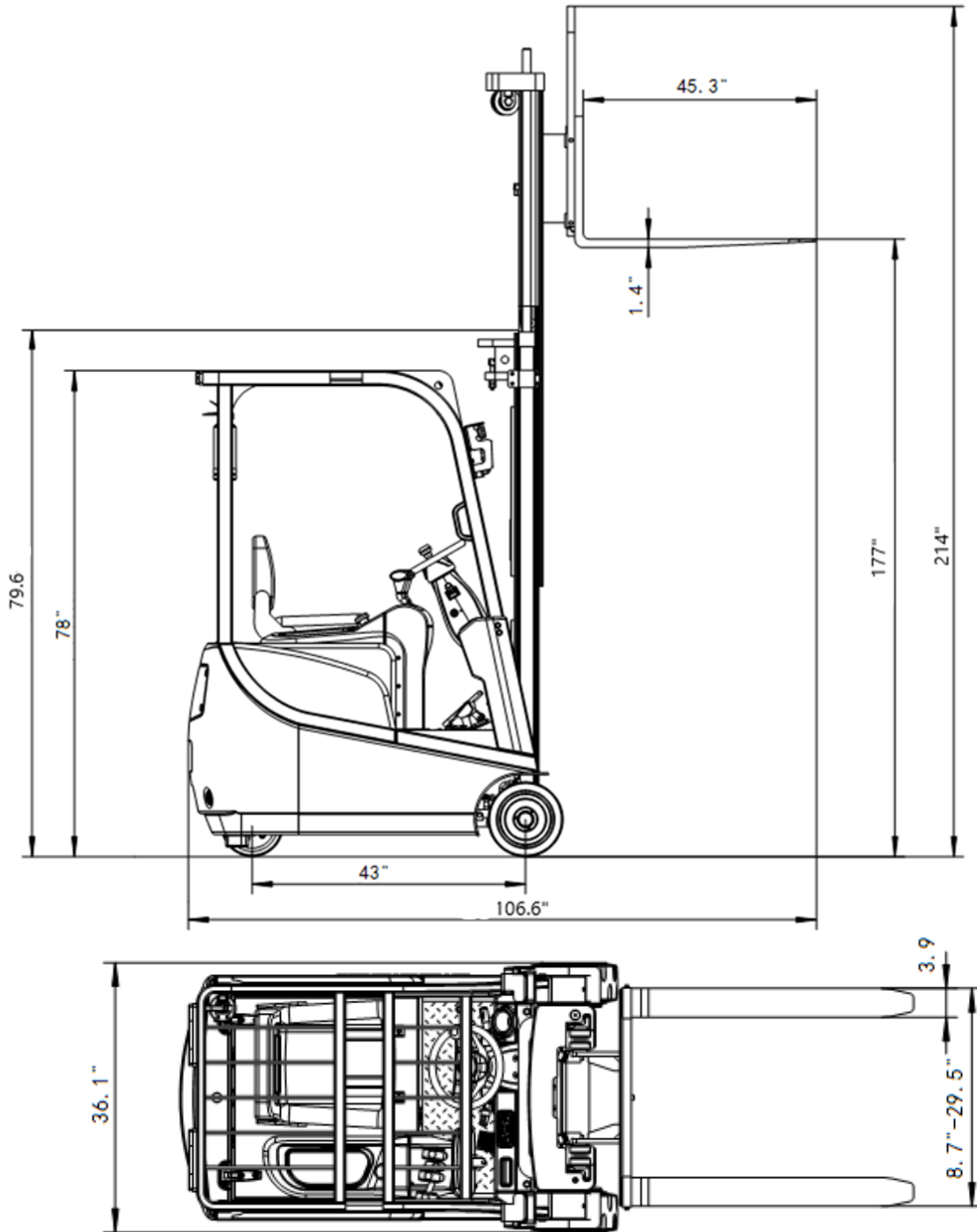

MODEL #	MAST	LIFT HEIGHT	MAX MAST HEIGHT	TOTAL LENGTH	SERVICE WEIGHT
EK15A	79.6"	177"	214"	106.6	5665