

EKKO[®]

MATERIAL HANDLING EQUIPMENT

MOVING AHEAD

WALKIE STRADDLE STACKER EB18E / EB20E

- 4000-4400 lbs. Capacity
- 138-177 in. Lift Height
- Narrow Aisles 8 ft.
- Adjustable Legs 45.5-59.1 in.
- Adjustable Forks 8.3-33.5 in.
- Curtis Instrument Controller
- Batteries and Charger Included
- 3 Year Limited Warranty



EB18E / EB20E SERIES

Superior quality, maneuverable, compact, and durable for all your material handling applications. Ideal for small aisles and areas.

WEIGHT CAPACITY: 4000-4400 lbs. @ 24" load center

LIFT HEIGHT: 138" or 177" (11.5 ft. to 14.75 ft.)

FORK LENGTH: 45.3"

ADJUSTABLE OUTRIGGERS: 45.7" - 59.1"

ADJUSTABLE FORKS: 8.3" - 33.5"

MAST HEIGHT: 82" or 92"

TURNING RADIUS: 60"

INTEGRAL BATTERY / CHARGER: 24V 160-210AH, 24-volt deep cycle maintenance-free batteries with external direct connect 110A 110VAC plug-in automatic 24V/20-30A charger (both Included)

SPEED TRAVEL: 3.3 mph empty ; 3.0 mph loaded

LIFTING SPEED: 5.35 ips empty; 3.6 ips loaded

LOWERING SPEED: 3.85 ips empty; 4.4 ips loaded

DRIVE WHEELS: 9" x 3" polyurethane

STABILITY: 4" x 2" polyurethane

LOAD WHEELS: (2) 4" x 3" polyurethane per outrigger

HYDRAULICS LIFTING MOTOR: 24V 2200 Watt lifting motor with hardened chrome moly steel for durability.

DRIVE MOTOR: 24V 750Watt AC drive motor for efficiency and high torque.

AC CONTROLLER: 24V CURTIS Instrument provides performance through entire range of speed; Constant travel speed regardless of load; Battery discharge indicator combination gauge.

BRAKES: Electro-magnetic braking for secure stopping power; Electronic neutral braking for accurate control.

OPERATOR CONTROLS: Throttle, lifting, lowering, turtle mode and horn functions are located in the ergonomic handle; Offset steering handle to provide better visibility; Belly button reverse safety feature allows the unit to stop and reverse to avoid collision or injury.

CHASSIS AND MAST: Robotic Welding; Heavy duty steel chassis with I-beam mast for durability; Telescoping mast includes a protective steel guard.



Walkie Straddle Stacker

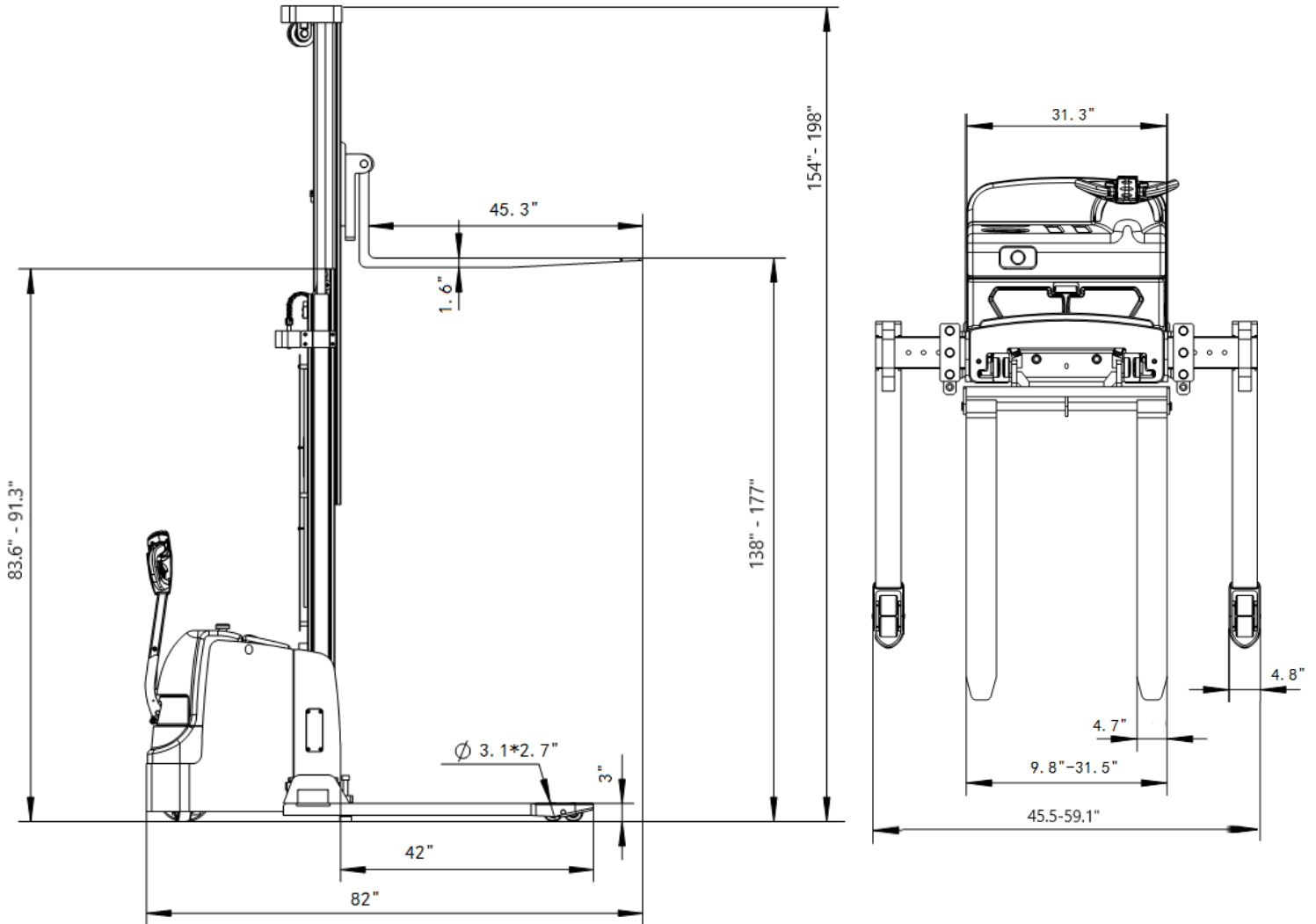

MODEL #	MAST	LIFT HEIGHT	MAX MAST HEIGHT	SERVICE WEIGHT
EB18E	91.3	138"	154"	2100
EB20E	83.6	177"	198"	2800