

ASSEMBLY INSTRUCTIONS

STEP #1--ASSEMBLY OF RACK END UNITS

FIGURE #1

- 1.) IN ORDER TO BUILD A RACK SECTION, YOU FIRST NEED TO MAKE UP TWO RACK END UNITS.
- 2.) TO MAKE UP AN END UNIT, ASSEMBLE TWO ANGLE POSTS (COMPONENT E) AND TWO DOUBLE-RIVET BEAMS. USE EITHER THE DOUBLE RIVET FLANGED (COMPONENT B), OR THE DOUBLE-RIVET CHANNEL BEAMS, DEPENDING ON YOUR CONFIGURATION AND LOAD REQUIREMENTS.
- 3.) THE BOTTOM BEAMS ARE TO BE NO MORE THAN 3" UP FROM THE FLOOR. USE A RUBBER HAMMER OR Mallet TO SEAT THE RIVETS INTO THE UPRIGHTS.

NOTE:

THE DOUBLE RIVET BEAMS ARE TO BE USED TO MAKE UP THE RACK END UNITS. THIS WILL RESULT IN THE STRONGEST RACK STRUCTURE.

STEP #2--ASSEMBLY OF SINGLE RACK FRAMES

FIGURE #2

- 1.) THE BASIC RACK FRAME CONSISTS OF TWO END UNITS AND FOUR DOUBLE RIVET BEAMS.

- 2.) ATTACH THE TWO BOTTOM DOUBLE RIVET BEAMS TO THE TWO END UNITS. USE A RUBBER HAMMER OR Mallet TO SEAT THE RIVETS INTO THE UPRIGHTS. THEN, ATTACH THE TWO TOP DOUBLE RIVET BEAMS.

- 3.) IF REQUIRED, INSTALL CENTER SUPPORT TIES (COMPONENT D) TO THE FRONT AND REAR BEAMS. THE CENTER SUPPORT IS TO BE INSTALLED BETWEEN THE BEAMS AT EVERY LEVEL, USING (4) 1/4"-20 NUTS AND BOLTS PROVIDED. REFER TO CATALOG FOR QUANTITY OF CENTER SUPPORTS REQUIRED BASED UPON LENGTH OF BEAMS USED.

NOTE:

THE DOUBLE RIVET BEAMS ARE TO BE USED TO MAKE UP THE RACK FRAMES. THIS WILL RESULT IN THE STRONGEST RACK STRUCTURE.

- 4.) BUILD UP THE VARIOUS INTERMEDIATE LEVELS AS DESIRED. USE EITHER THE SINGLE-RIVET, THE DOUBLE RIVET-FLANGED, OR THE DOUBLE-RIVET CHANNEL BEAMS, DEPENDING ON YOUR CONFIGURATION AND LOAD REQUIREMENTS.

ASSEMBLY OF CONSECUTIVE RACK FRAMES

FIGURE #3

- 1.) FOR ATTACHING TWO OR MORE EXISTING SINGLE RACK ASSEMBLIES TOGETHER, USE THE TIE PLATES (COMPONENT G).
- 2.) AS AN OPTION, YOU MAY USE THE "T" POST STYLE UPRIGHTS FOR THE INTERMEDIATE RACK ENDS (COMPONENT F). BOTH WILL YIELD THE SAME RESULT.
- 3.) FOLLOW THE SAME GUIDELINE IN STEPS 1 AND 2 FOR COMPLETION OF THE SECTIONS.

FOOT PLATE ATTACHEMENT (OPTIONAL)

FIGURE #4

- 1.) IF FOOT PLATES WERE ORDERED, ATTACH FOOT PLATE (COMPONENT H) TO ANGLE POST UPRIGHT USING (1) 5/16-12 X 1/2" SLOTTED HEAD SHEET METAL SCREW. POSITION FOOT PLATE SO THAT MAJORITY OF THE FOOTPLATE IS BENEATH THE UNIT.
- 2.) IF FOOT PLATES WERE ORDERED, ATTACH FOOT PLATE (COMPONENT H) TO "T"-POST UPRIGHT USING (2) 5/16-12 X 1/2" SLOTTED HEAD SHEET METAL SCREWS.
- 3.) THE SHEET METAL SCREWS ENGAGE INTO THE HOLE IN THE LOWEST BEAM, WHEN PLACED AT THE LOWEST POSITION.

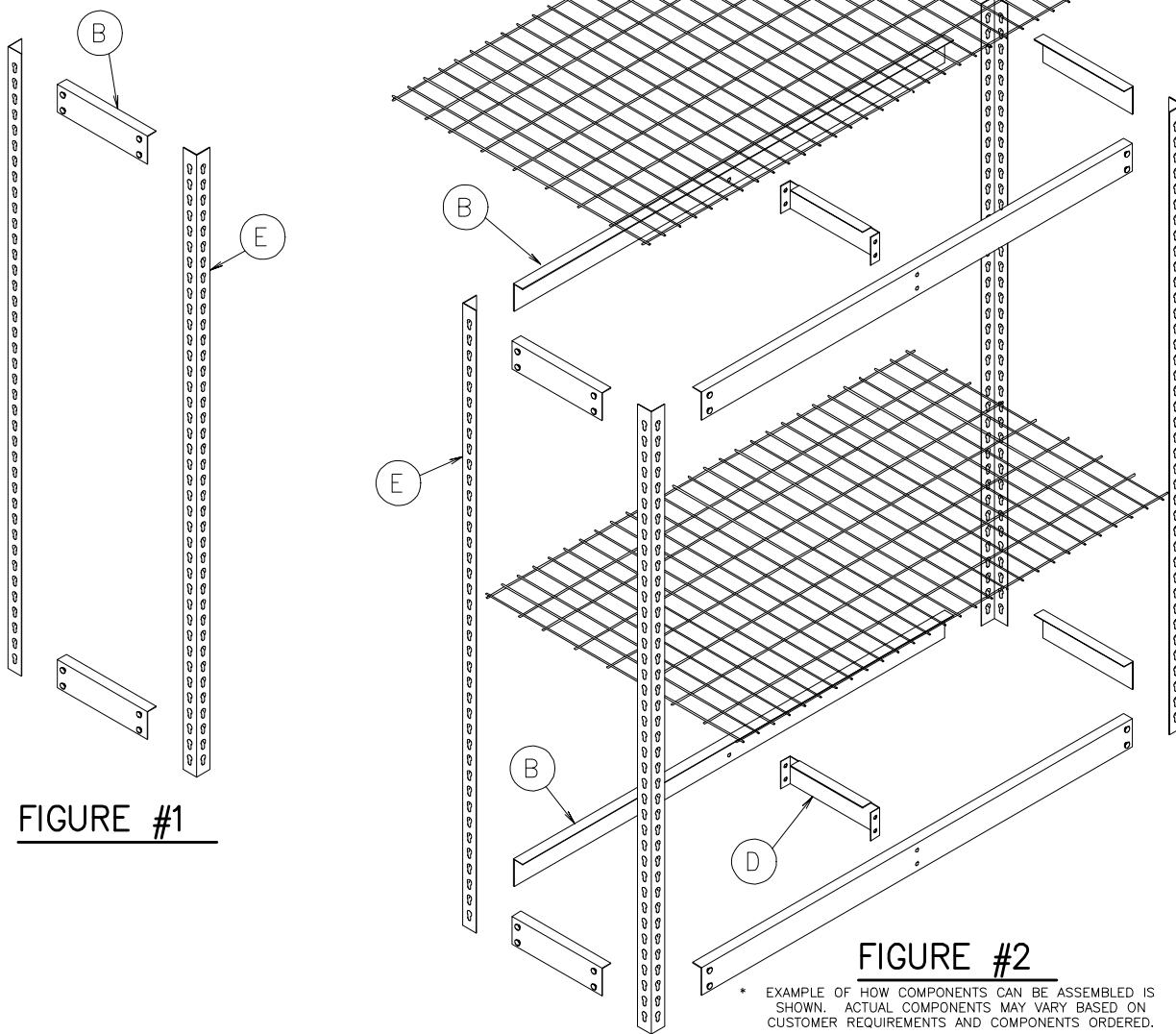

FIGURE #1

FIGURE #2

* EXAMPLE OF HOW COMPONENTS CAN BE ASSEMBLED IS SHOWN. ACTUAL COMPONENTS MAY VARY BASED ON CUSTOMER REQUIREMENTS AND COMPONENTS ORDERED.

COMPONENT IDENTIFICATION

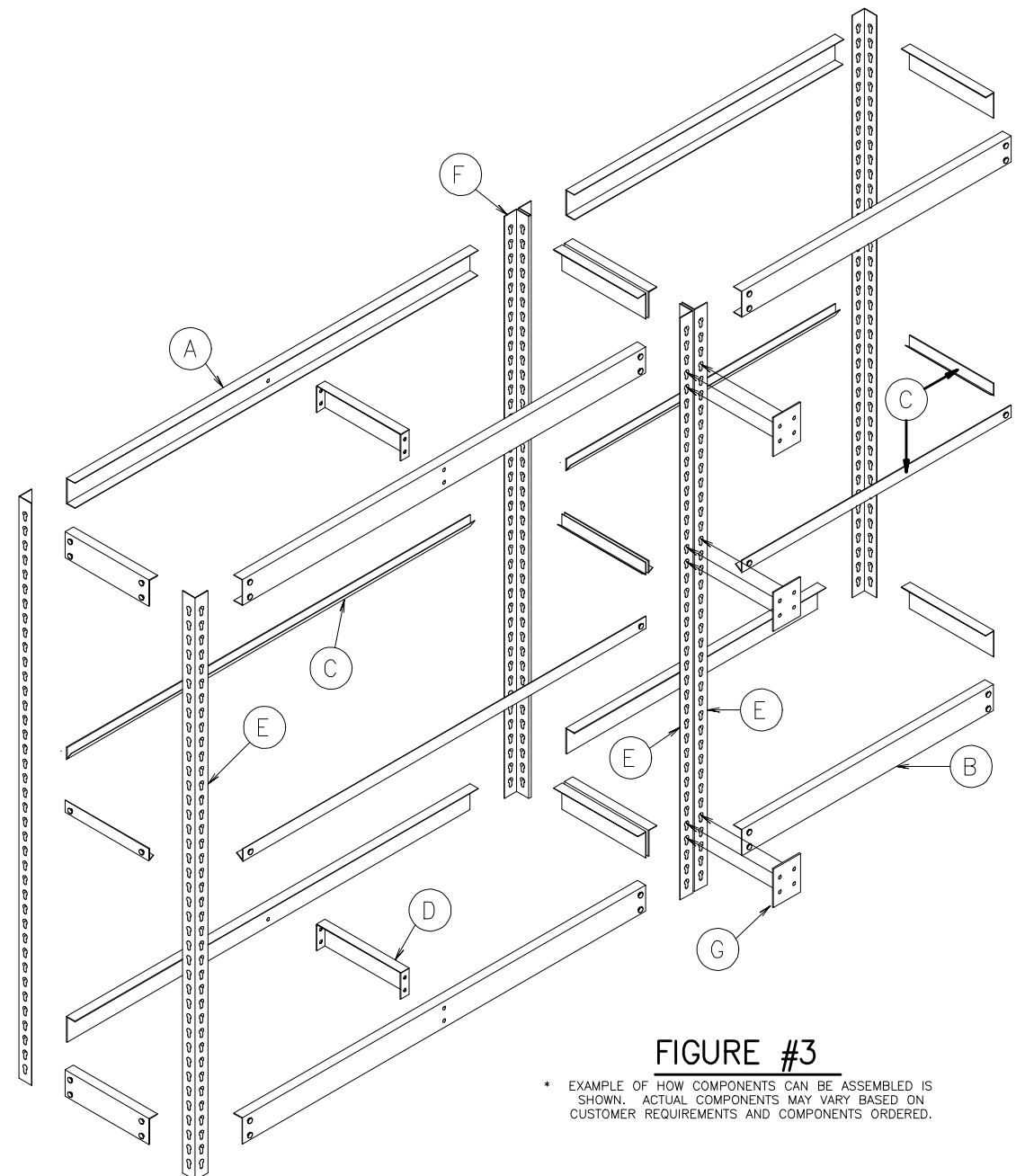
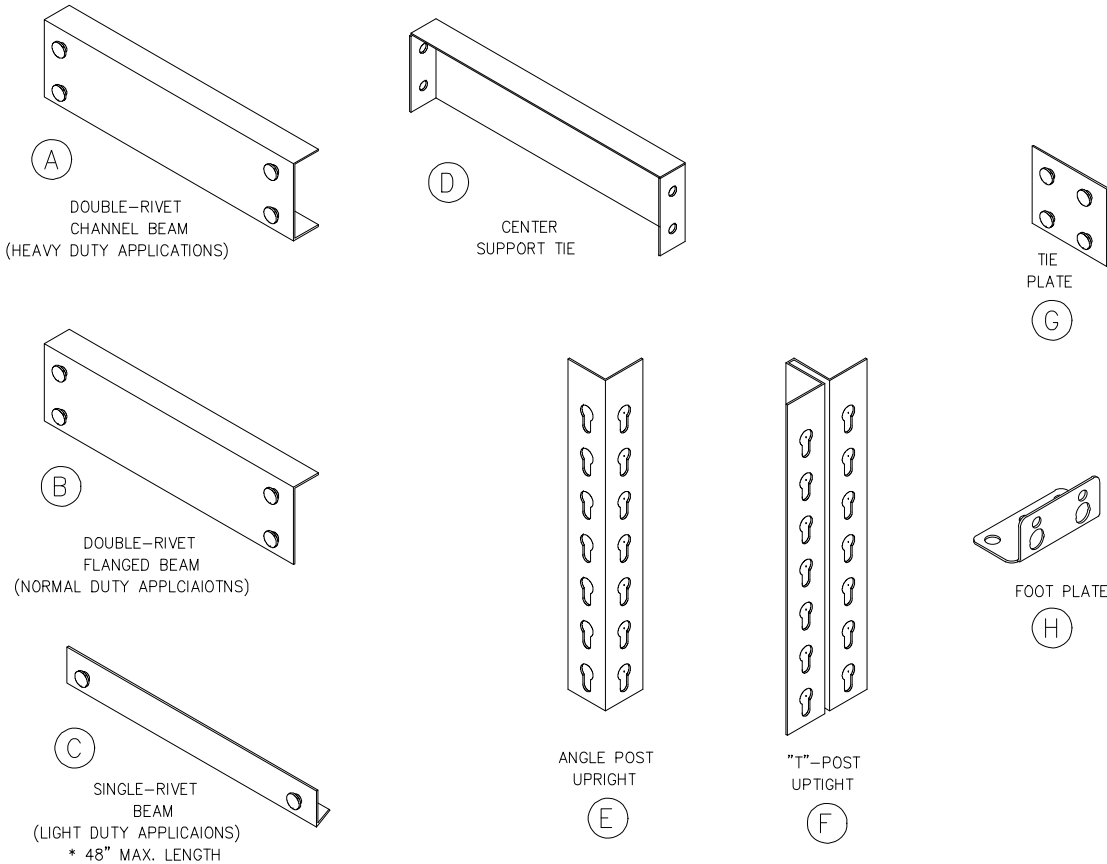

FIGURE #3

* EXAMPLE OF HOW COMPONENTS CAN BE ASSEMBLED IS SHOWN. ACTUAL COMPONENTS MAY VARY BASED ON CUSTOMER REQUIREMENTS AND COMPONENTS ORDERED.

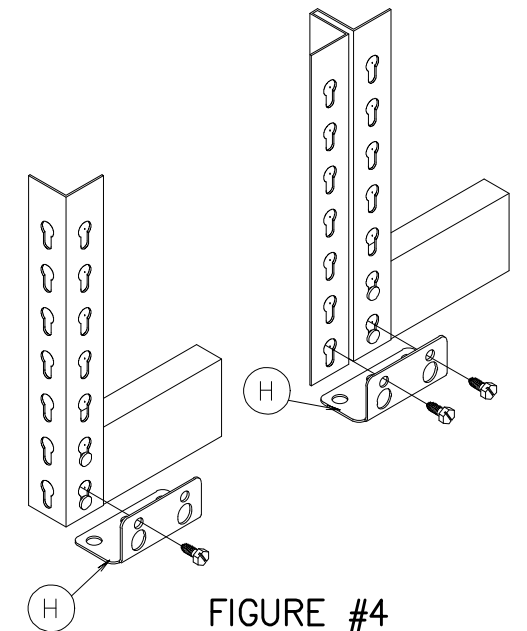

FIGURE #4

* FOOT PLATE IS AN OPTIONAL ACCESSORY AND MUST BE ORDERED SEPARATELY

ASSEMBLY INSTRUCTIONS FOR BOLTLSS RIVET RACK SHELVING

UGH REPUBLIC LYON LYON GROUP HOLDINGS

REVISIONS CORR. VIEW ADDED FIG. 4 E-190701-01 E-200303-1 E-200319-1

RIVET RACK

SHEET 1 OF 1