



# Stair Trac

Portable Wheelchair Lift



# Technical Information

## Specifications

---

Load Capacity	150 kg (330 lbs)
Weight	59 kg (130 lbs)
Speed	Up: 6.1 meters (20 ft) per minute Down: 10.7 meters (35 ft) per minute
Operating Controls	Constant pressure drive control switch
Motor	12V DC
Batteries	2 x 6V - 20A hours
Maximum Charge Rate	4 amp
Optimum Stair Angle	35°
Typical Battery Charge Capacity	650 stairs

## Features

---

- Attaches to most standard manual wheelchairs with push handles
- Robust battery - fully charged it can carry 150 kg (330 lbs) up 30 flights of stairs
- Works on virtually any indoor or outdoor stairway
- Stable and self supporting
- Durable steel reinforced rubber tracks grip stairs securely
- Detachable support handle for compact storage and easy transport
- Quick release safety belt
- Key switch controls unauthorized use
- Rechargeable batteries and charger
- Optional Vehicle Loading Ramp (see opposite page)

## Benefits

---

- An economical alternative to stairway lifts and elevators
- May be used on several different stairways
- Provides accessibility where power is unavailable
- Stores easily when not in use
- Requires minimal maintenance
- Available immediately
- 5 year limited warranty

# Dimensions

## Assembled Equipment Dimensions

---

Height	903 mm (35 5/8")
Length	1453 mm (57 1/4")
Width	644 mm (25 3/8")

## Clearance Dimensions

---

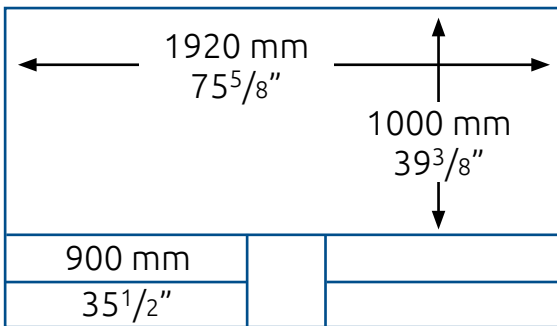

### Required Clearances

This diagram (left) shows typical clearances required on turnback stairways. Dimensions vary slightly with stairway width and operator experience.

## Optional Loading Ramp

---



The optional vehicle loading ramp allows the Stair-Trac to be easily and safely loaded and unloaded from vehicles using the drive motor.