

Vinkøleskab

Betjeningsvejledning

CCI92DB

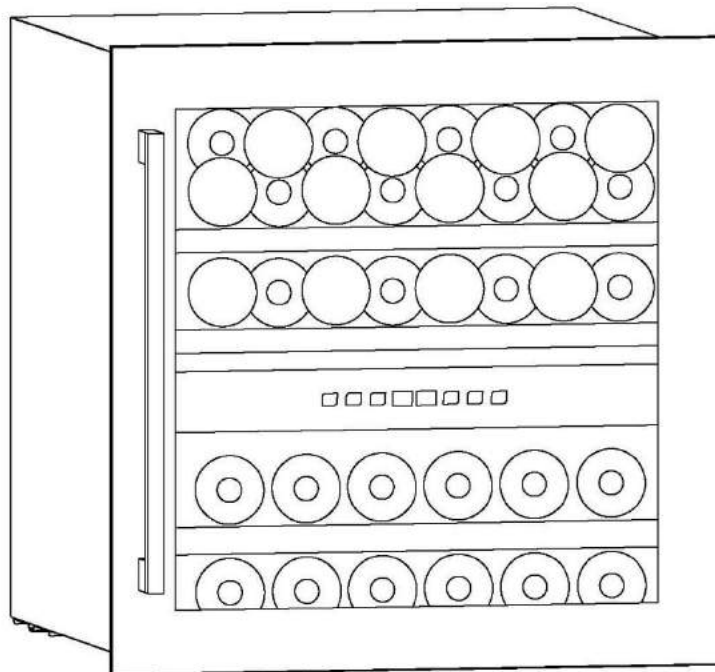

Tak for dit køb af dette vinkøleskab, vi håber du bliver tilfreds med at opbevare din vinsamling.



Indhold

Sikkerhed og advarsler.....	DK1- DK 2
Installation.....	DK 3
Beskrivelse af apparatet.....	DK 4-6
Operation.....	DK 6- DK 9
Problem løsning.....	DK 10
Vedligehold og rengøring.....	DK 11
Tekniske specifikationer.....	DK 12

Sikkerhed og advarsler

Din sikkerhed er yderst vigtig for vores firma. Venligst læs denne vejledning inden du tager apparatet i brug. Skulle du være tvivl om nogle informationer i denne vejledning, venligst kontakt os.



Forbud



Advarsel



Bemærk



Bemærk

- Dette apparat bør ikke betjenes af børn. Børn må ikke lege med apparatet, da der kan fare forbundet.
- Dette apparater beregnet til brug i private hjem og ikke til professional eller industrielt brug.



Advarsel

- Hold ventilations åbninger frie på apparatet og udluftning fri ved indbygning.
- Brug ikke mekaniske apparater eller andre redskaber for at gøre afrimning og optøning hurtigere.
- Ødelæg ikke kølerør og lignende.
- Benyt ikke elektriske apparater inden i skabet.
- Apparatet må kun tilsluttes strøm i.h.t. til ratinglabel på siden eller bagsiden af apparatet.
- Tilslut apparatet til 220-240 V / 50 Hz vekselstrøm via en korrekt installeret stikkontakt med jordforbindelse. Stikkontakten skal være sikret med en

10 -13 A sikring. Vinkøleskabet leveres med en såkaldt Schuko stikprop som er standarden i de fleste lande i europa. Dette er et 2-benet stikprop med sidejord.

Mange danske hjem har en stikkontakt med dansk jord (3 ben). I de tilfælde skal du tilkøbe en adapter hos din forhandler, som nemt klikkes på. Alternativt skal du eller en autoriseret elinstallatør skifte stikproppen til den danske 3-benede stikprop som du ligeledes kan købe hos din forhandler.

- Stikket bør være nemt tilgængeligt i tilfælde nødstop.
- Opbevar ikke benzin, brandbare væsker, og lignende indeni eller i nærheden af apparatet.

Børne sikkerhed

- Tillad ikke børn at lege inden i skabet, da de kan blive spærret inde.
- Tillad ikke børn at lege med eller hænge på døren, da skabet kan vælte.
- Tillad ikke børn at røre ved kompressor eller andre ting under skabet pga. fare.

Vinkøleskabet tåler ikke vand

- Sprøjt eller hæld ikke vand i skabet, da det kan kortslutte.

Pas på fryseskader

- Rør ikke ved de indvendige flader med våde hænder, da det kan give fryse skader.

Åben ikke døren i længere tid

- Hvis døren er åben i lang tid vil det påvirke skabet køleevne.

Modificer ikke skabet

- Lav ikke konstruktions ændringer på skabet, da det kan ødelægge apparatet.

Sluk for strømmen og træk stikket ud hvis:

- Sluk for strømmen og træk stikket ud før rengøring og vedligehold.

- Træk stikket ud i tilfælde af strømsvigt i huset eller området.

Bortskaffelse af apparatet

- Skal afleveres på den nærmeste genbrugs plads
- Før du smider apparatet ud bør døren afmonteres, så børn ikke leger med apparatet



FORBUDT

Lav ikke skader på ledningen

- Træk ikke stikket ud ved at hive i ledningen, men kun ved at trække stikket ud.
- Stil ikke apparatet oven på ledningen.
- Rul ledningen sammen når skabet flyttes for at undgå skader.

Hvis ledninger er skadet

- Brug ikke ledningen hvis den er skadet, få en ny monteret af autoriseret montør.

Installation

Position

- ⚠ ved flytning af apparatet bør det ikke vippes over 45°.
- ⚠ Placer ikke apparatet i et fugtigt rum.
- ⊘ Placer ikke apparatet i et rum der ikke er frost frit.
- ⊘ Placer ikke apparatet udendørs.

Dette vinkøleskab er designet til indbygning.

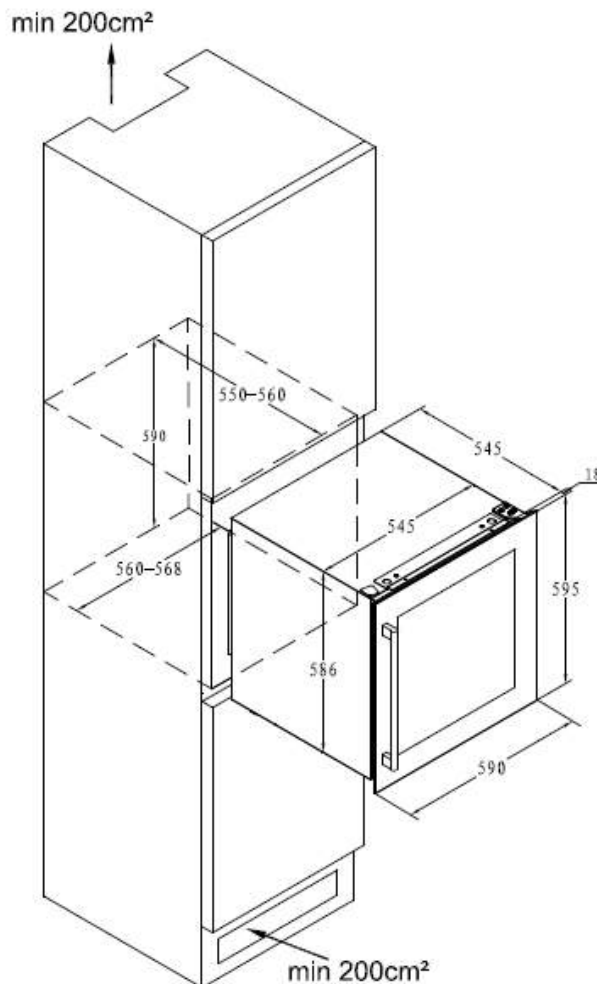

Vinflasker kan opbebares i skabet, så snart du kan mærke køling i skabet, efter ca. 1 time

Beskrivelse af apparatet

Tilbehør og navne

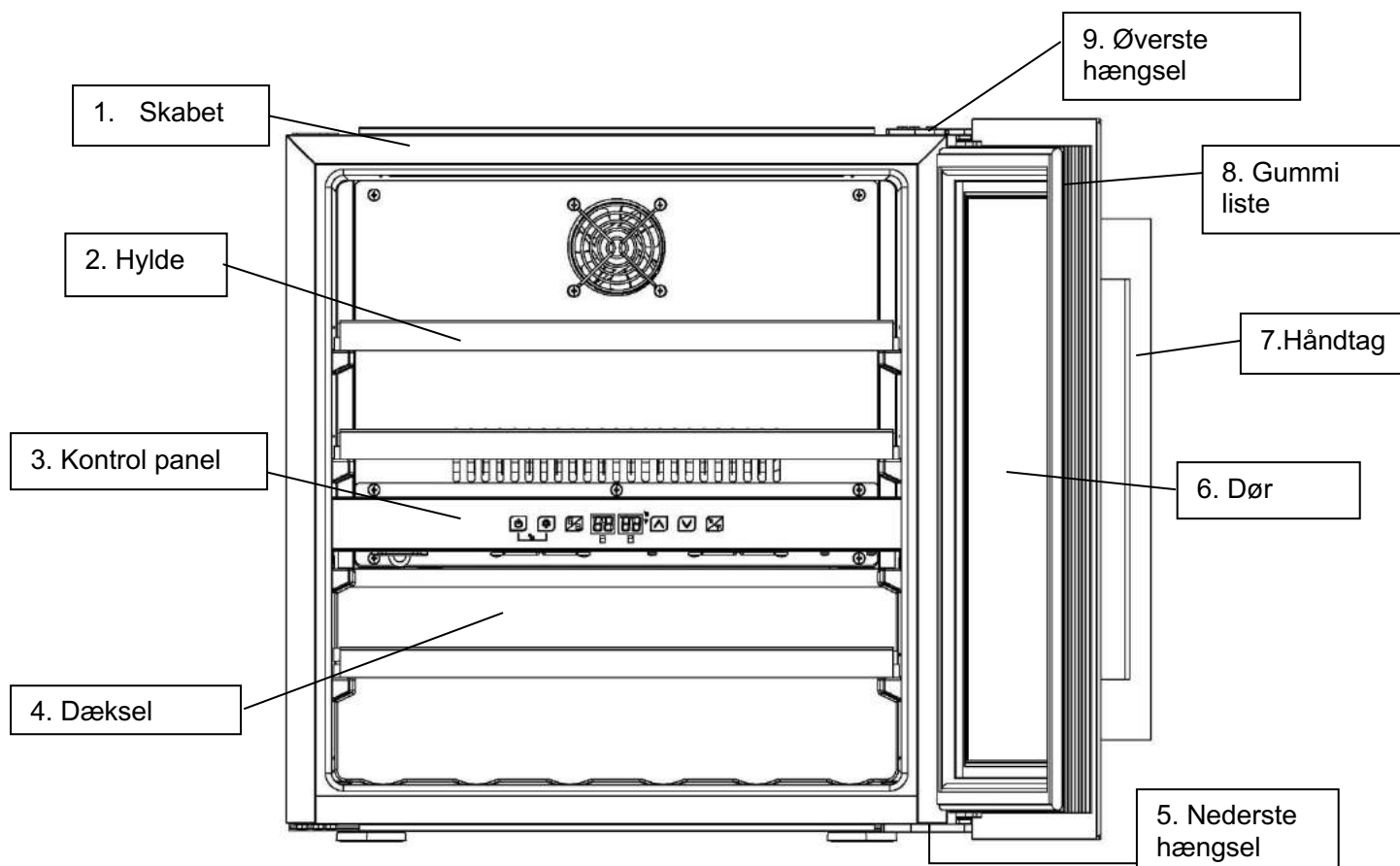

Note: Hylde, dør ramme, håndtag og andre dele kan være forskellige på forskellige modeller. Alle foto og tegninger i denne manual er kun for reference.

Installation af dørhåndtag og vending af døren

1. Monter håndtaget på dør rammen.

Håndtaget følger med i en separate pakke med skruer og ligger i skabet.

① Ved at trække et lille stykke af gummilisten fri, kan man se 2 småskruer huller i dørrammen ② Sæt skruerne i hullerne indefra og monter håndtaget på ydersiden af døren ③ Stram skruerne med en skruetrækker ④ Sæt gummi listen på plads igen.

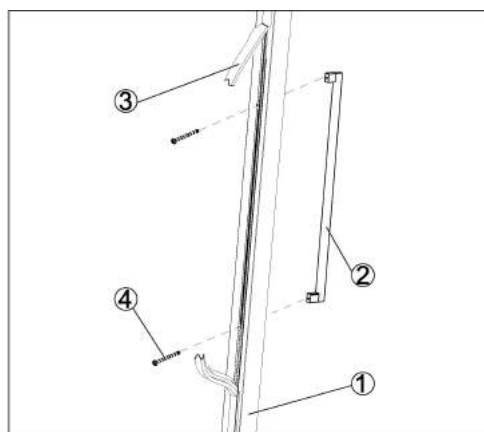

2. Vending af døren

Vinkølskabet er leveret med åbning fra venstre til højre. For at vende åbningsretningen:

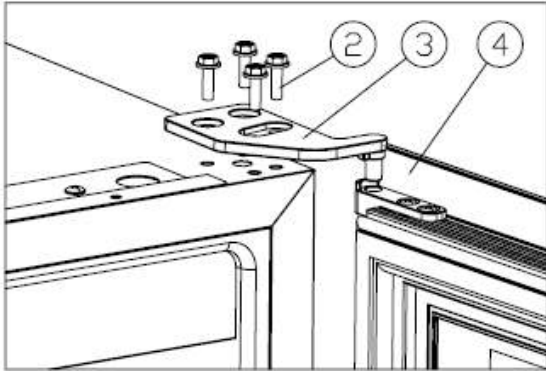

Figur 1

- ✧ Åben døren 90 grader og hold den stille.
- ✧ Løsn M5*16 skruerne (2), Fjern det øverste hængsel, mens døren holdes (3), og løft døren af.[Figur 1].

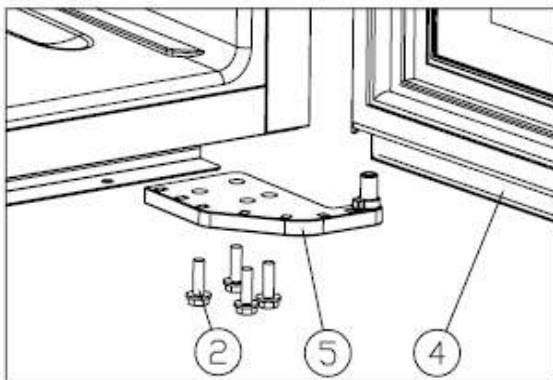

Figure 2

- ✧ Løsn M5*16 skruerne (2), fjern det nederste hængsel (5). [Figur 2]

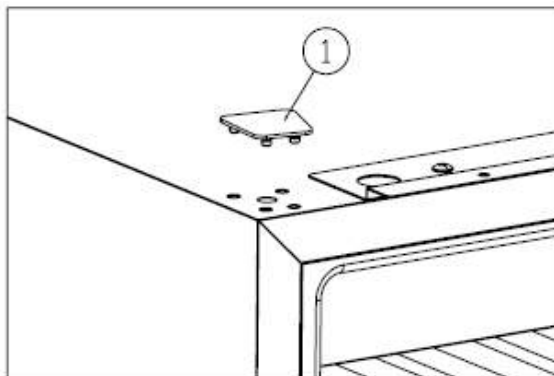

Figure 3

- ✧ Fjern det midlertidige dæksel (1). [Figur 3]

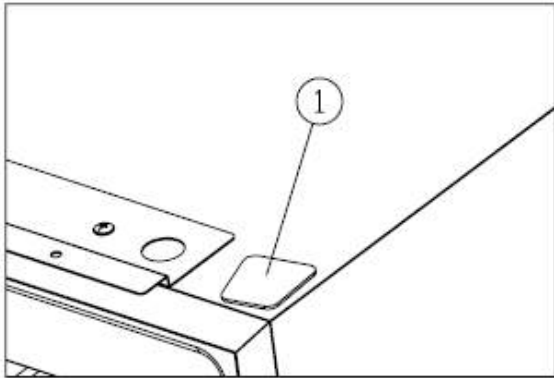

Figure 4

- ✧ Monter det midlertidige dæksel i modsatte side ①. [Figur 4]

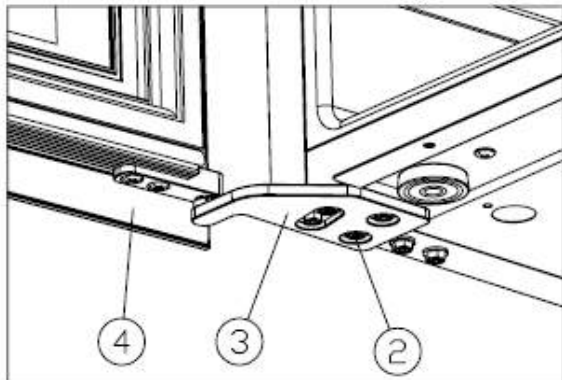

Figure 5

- ✧ Monter det øverste hængsel ③, og stram M5*16 skruer ②. [Figur 5]

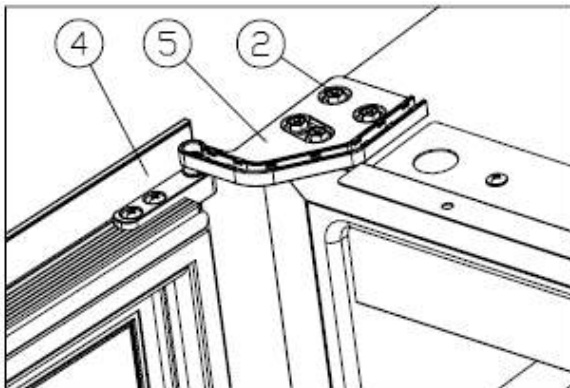

Figure 6

- ✧ Vend døren ④ 180 grader rundt, og monter det nederste hængsel ⑤, Stram M5*16 skruerne ②. [Figur 6]. Vending af døren er foretaget.

Betjening

Opstart

1. Rengøring af skabet

Før strømmen tilsluttes bør apparatet rengøres. (For detaljer, se “Vedlige og Rengøring”)

2. Placering

Før skabet tilsluttes strøm, bør det stå i mindst 30 minutter.

3. Tilslut og Tænd

Apparatet vil starte nedkøling som tager ca. 1 time inden det kan mærkes.

Kontrol panel

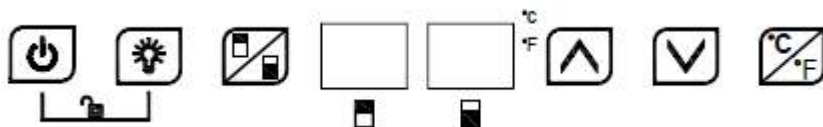

Alle knapper virker ikke hvis skabe er i “Låst mode”. Husk at låse op først.



Tænd / Sluk

1. Hold knappen inde i 3 sekunder, for at tænde.
2. Hold knappen inde i 3 sekunder for at slukke.



Lys

Tryk på knappen, for at tænde eller slukke Led lyset inde i skabet.



Zone skift

Tryk på knappen for at skifte mellem øverste og nederste ved temperature skift. Ved et tryk, blinker LED displayet. Tryk op og ned knapperne for skifte temperature. Tryk igen for at skifte zone.



OP

Tryk på knappen een gang, LED Display blinker og viser den faktiske temperatur. Fortsæt med at trykke for at justerer den ønskede temperatur, et tryk øger temperturen med 1°C. Efter 5 sekunder uden tryk på knappen holder displayet op med at blinke og den ny tempertur er sat. LED displayet viser nu den faktiske temperatur I skabet.

 **NED**

Tryk på knappen een gang, LED Display blinker og viser den faktiske temperatur. Fortsæt med at trykke for at justerer den ønskede temperatur, et tryk sænker temperturen med 1°C. Efter 5 sekunder uden tryk på knappen holder displayet op med at blinke og den ny tempertur er sat. LED displayet viser nu den faktiske temperature i skabet.



 **Børne lås (Kombinations knapper)**

1. Lås: Trykke begge knapper samtidigt i 3 sekunder for at låse.
2. Lås op: Trykke begge knapper samtidigt i 3 sekunder for at låse op.



Fahrenheit/Celsius display Skift

Skift temperaturvisning i displayet mellem Fahrenheit og Celsius ved at trykke på knapper.



Bemærk

1. Temperaturen kan justeres fra **5 til 22°C i både den øverste og nederste zone**. Temperaturen i den nederste zone kan kun sættes til at være den samme eller højere end den nederste temperatur.
2. Alarm lyd: Hvis systemet svigter vil en alarm lyde. Tryk på en vilkårlig knap på kontrol panelet for at annullere lyden.
3. Fejlkode:
Hvis en temperature sensor svigter, vil displayet vise E1 for midlertidig fejl; E2 for kortslutning. Hvis temperaturføleren svigter vil der komme en fejlkode; E5 for afbrudt forbindelse og E6 for en kortslutning. Hvis defrost sensoren svigter vil der komme en fejlkode E3 for afbrudt forbindelse og E4 for en kortslutning.

Opbevaring af vin

- ✧ Dette vinkøleskab har individueller hylder til opbevaring af din vin, stille og roligt uden at flasken skal flyttes hele tiden.
- ✧ 2+1 træhylder kan opbevare: **36** flasker. (standard Bordeaux 750ml)

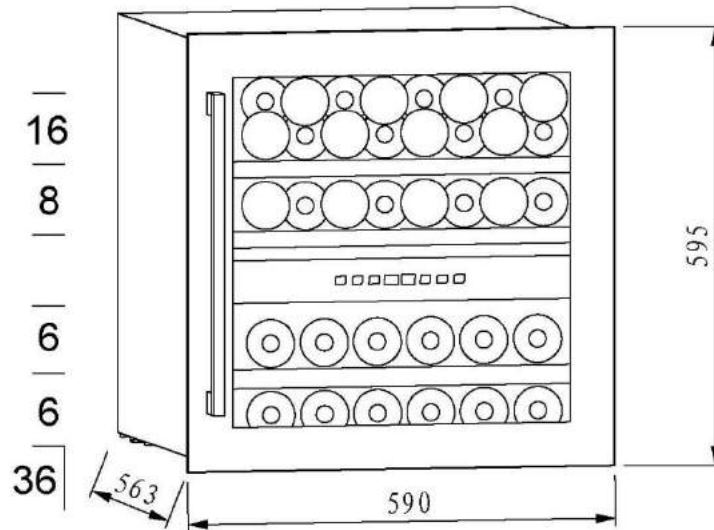

- ✧ Opbevarings kapacitet kan variere i.h.t. flaskernes placering og størrelser.
- ✧ Hver hylde er designet to 1 eller 2 lag af flasker. Mere end 2 lag af flasker per hylde kan ikke anbefales.
- ✧ Hver hylde kan trækkes delvis ud for nemmere adgang.
- ✧ Åben døren helt op inden hylderne trækkes ud.
- ✧ Hvis skabet er tomt i længere tid, anbefaler vi at skabet slukkes, rengøres, og åben døren for udluftning.
- ✧ Nedenstående er vores anbefaling for temperaturer til opbevaring og drikning:

Rødvin	15-18°C
Hvidvin	9-14°C
Rosevin	10-11°C
Champagne & Mousserende	5- 8°C

Problem løsning

Apparatet larmer meget	<ul style="list-style-type: none"> ● Juster de foreste fødder, for at holde apparatet i water/lige ● Undgå at apparatet rører ved væggen bag.
Væske lyd indenfra skabet	<ul style="list-style-type: none"> ● Dett er er normal medens apparatet kører
Apparatet kan ikke starte	<ul style="list-style-type: none"> ● Forvis dem om at stikket er sat i og strømmen tændt ● Kompressoren vil auto starte efter 5 minutter efter strømsvigt
Kompressoren kører hele tiden	<ul style="list-style-type: none"> ● Hvis der ikke producers kulde skal der ringes efter service
Dør gummiliste slutter ikke tæt	<ul style="list-style-type: none"> ● Efter lang tids brug kan gummilisten blive stiv og ude af facon. 1. Opvarm gummilisten med varm luft blæser eller et varmt håndkæde.
Apparatet køler ikke effektivt	<ul style="list-style-type: none"> ● Juster temperature på displayet ● Hold apparatet væk fra sollys og varmekilder. ● Åben ikke døren konstant.
Ubehagelig lugt inde i skabet	<ul style="list-style-type: none"> ● En smule plastik lugt i nye apparater er normalt og vil forsvinde efter et stykke tid. ● Rengør apparatet og udluft det i et stykke tid
Kondensvand på glas døren	<ul style="list-style-type: none"> ● Åben ikke døren konstant, lad den være lukket i længere tid. Sæt ikke temperature for lavt ● Høj temperatur og luftfugtighed i omgivelserne skaber også kondens i skabet
Lyset virker ikke?	<ul style="list-style-type: none"> ● Forvis dem om stikket er sat i og strømmen tændt. ● Ring efter service hvis lyset er itu

Vedligehold og rengøring

Rengøring

- Sluk for strømmen og træk stikket ud inden rengøring begyndes.
- Rens apparatet med en fugtig klud eller svamp med vand.
- Brug ikke rengøringsmidler, opvaskemiddel, kogende vand, vaskepulver eller lignende.
- Skyl ikke apparatet hverken indvendigt eller udvendigt.

Nedenstående vil ødelægge overflade på apparatet:

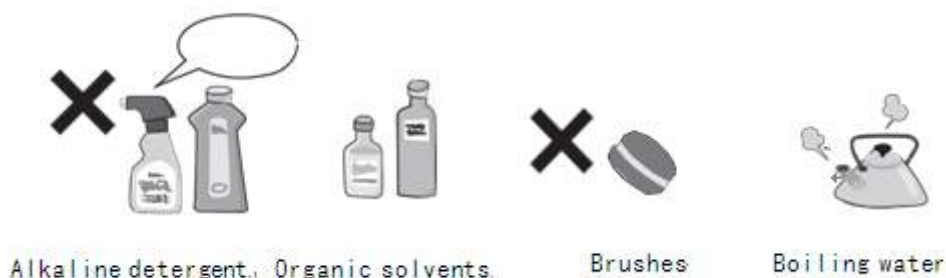

Strømsvigt

De fleste strømsvigt ophører efter kort tid. For at beskytte vinen i tilfælde af strømsvigt bør du undgå at åbne døren.

Ude af brug i længere tid

Fjern alle flasker fra apparatet, sluk apparatet og træk stikket ud, defrost, rengør skabet og lad døren stå åben for udluftning.



Hvis apparatet slukkes eller der er strømsvigt, vent venligst 5 minutter inden gen-start.

Flytning af apparatet

- Sluk for strømmen og træk stikket ud
- Fjern alle flasker.
- Under flytning må apparatet ikke tippes/ hælde mere end 45°.



Tekniske specifikationer

Product model	CCI92DB
Volt/frekvens	220-240V~/50Hz
Kølemiddel/vægt	R600a/25g
Effektiv volume	85 L
Flaske kapacitet	36 flasker
Net vægt	34 kg
Skabets størrelse (BxDxH)	590×563×595mm
Pakke størrelse (BxDxH)	650×650×655mm

Bemærk :

1. Netto vægten er inklusiv hylder og størrelse er uden håndtag monteret.
2. Yderligere oplysninger ses på siden eller bagsiden apparatets label
3. Flaske kapacitetkan varierer alt efter antal hylder og flaske størrelser (standard Bordeaux with 750ml er brugt her).



Wine Cooler

Instruction Manual

CC192DB

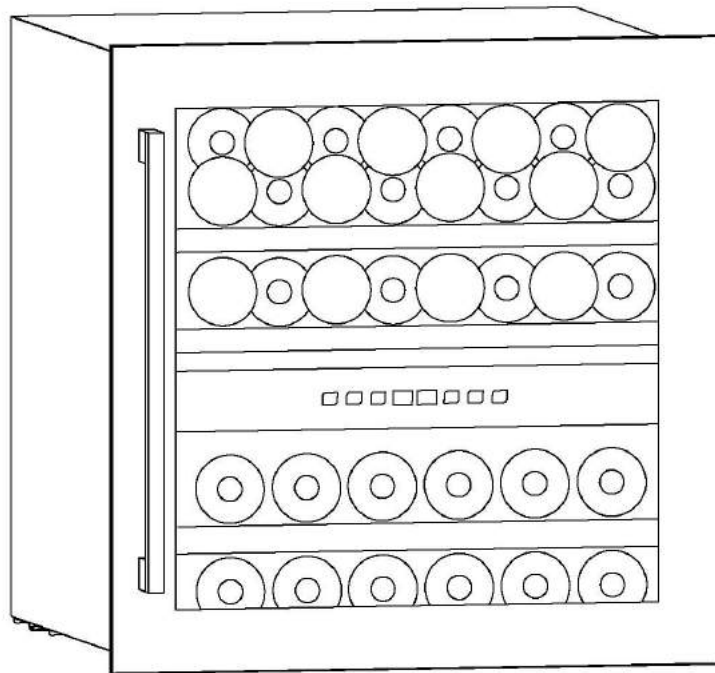

***NOTE: Thank you for your purchase and use our wine cooler !
Our product will create perfect temperature and humidity
environment to store your collection of wine quietly and peacefully.***

www.cavecool.com



Content

Safety instructions & warnings.....	EN1- EN 2
Installation.....	EN3
Description of the appliance.....	EN 4- EN 6
Operation.....	EN 6- EN 9
Troubleshooting.....	EN 9
Maintenance and cleaning.....	EN.10
Technical parameters.....	EN 11

Safety instructions & warnings

Your safety is of the utmost importance to our company. Please make sure that you read this instruction booklet before attempting to install or use the appliance. If you are unsure of any of the information contained in this booklet, please contact the Technical Department.



Prohibition



Warning



Caution



Caution

- This appliance can be used by children aged from 8 years and above and persons with reduced physical, sensory or mental capabilities or lack of experience and knowledge if they have been given supervision or instruction concerning use of the appliance in a safe way and understand the hazards involved. Children shall not play with the appliance. Cleaning and user maintenance shall not be made by children without supervision.
- Children aged from 3 to 8 years are allowed to load and unload refrigerating appliances. Children should be supervised to ensure that they do not play with the appliance.
- This appliance is intended for HOUSEHOLD USE ONLY and not for commercial or industrial use.



Warning

- Keep ventilation openings, in the appliance enclosure or in the built-in structure, clear of obstruction.

- Do not use mechanical devices or other means to accelerate the defrosting process, other than those recommended by the manufacturer.
- Do not damage the refrigerant circuit.
- Do not use electrical appliances inside the storage compartments of the appliance, unless they are of the type recommended by the manufacturer.
- Make sure that the appliance is connected to power supply in accordance with the rating label.
- Use an independent grounded socket with 10A or higher, do not connect to transformer or socket with multiple outlets.
- Make sure socket is grounded properly and do not modify power cord & plug.
- Connect power plug with socket firmly in case of possible risk of fire.
- Plug should be within reach for easy disconnection after the appliance positioned in case of accidents occurred.
- Do not store or burn gasoline or other inflammables near the appliance in case of possible fire.

- Do not store inflammables, explosives, acid & alkaline liquids etc. in the compartment of the appliance.
- Do not operate other appliances in the compartment.

Child Safety

- Do not allow child play inside the appliance in case of entrapment.
- Do not allow child hang on the door to play in case of falling of the appliance.
- Do not allow child reach into compressor compartment or touch metal components at rear of the appliance in case of possible injury.

Keep away from water

- Do not spray water on the appliance or wash the appliance by pouring or filling water in case of invalid insulation and possible electric shock.

Be careful of freezing

- Do not touch surface of the liner inside the compartment, especially with wet hand, in case of frozen injury while the appliance is in operation.

Do not open the door for long periods

- Opening the door for long periods can cause a significant increase of the temperature in the compartments of the appliance.

Modification on the appliance not allowed

- Do not reconstruct the appliance by yourself which might cause damages to the appliance.

Unplug the appliance under certain conditions

- Unplug the appliance before cleaning & maintenance.
- Unplug the appliance when power cut occurred.

Disposal of the appliance

- Please according to local regulations regarding disposal of the appliance for its flammable refrigerant and blowing gas.
- Before you scrap the appliance, please take off the doors to prevent children trapped.
- Send the appliance to the designated disposal location.

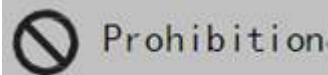

Do not damage the power cord

- Do not disconnect the appliance by pulling power cord rather than pulling the plug.
- Do not set the appliance above the power cord or step on the cord intentionally.
- Put the power cord at right place when moving the appliance.





When the power cord is damaged

- Do not use damaged power cord, and get it replaced immediately by manufacturer service agent or by qualified electrician.
- If needed, extend the power cord with cord of 0.75mm² or bigger by qualified electrician.



Installation

Position

-  Do not lean the appliance over 45° when moving it to position.
-  Do not put the appliance in the wet place.
-  Do not use the appliance in the frozen place.
-  Do not use the appliance outdoor in case of sunlight or rain.

The appliance is designed to fully build into the cabinet.

Demonstration for building into the cabinet:

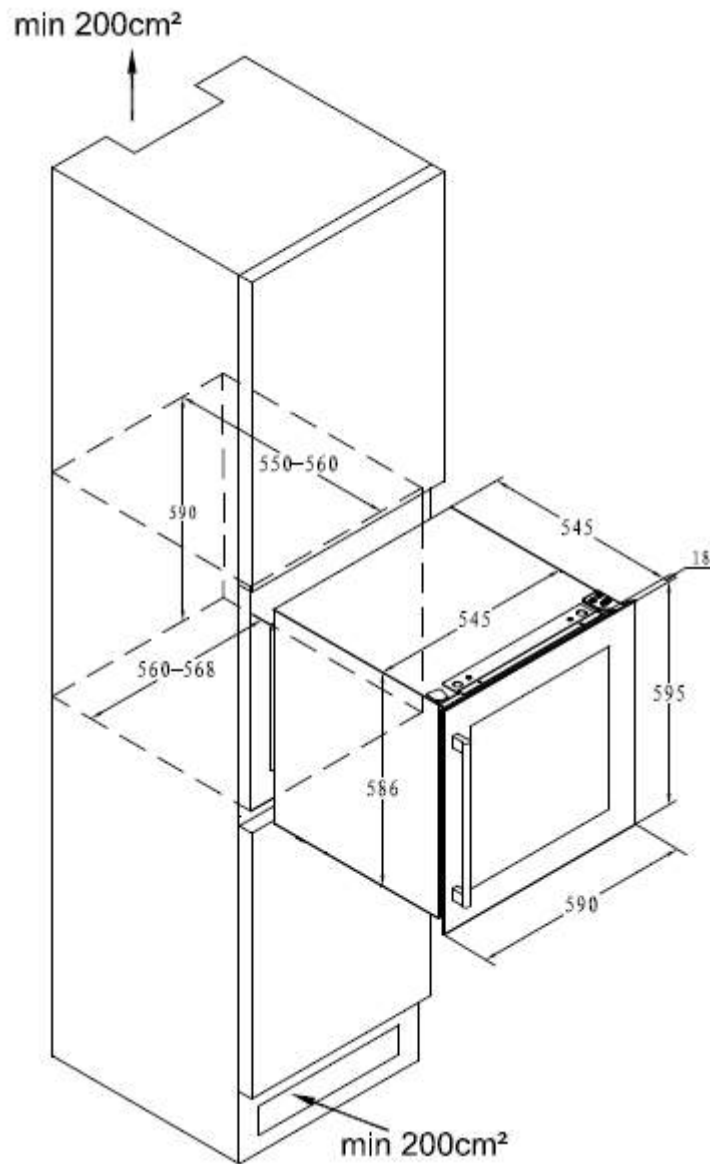

Wine bottles could be stored when you feel cooling inside after the appliance operates around 1 hour.

Description of the appliance

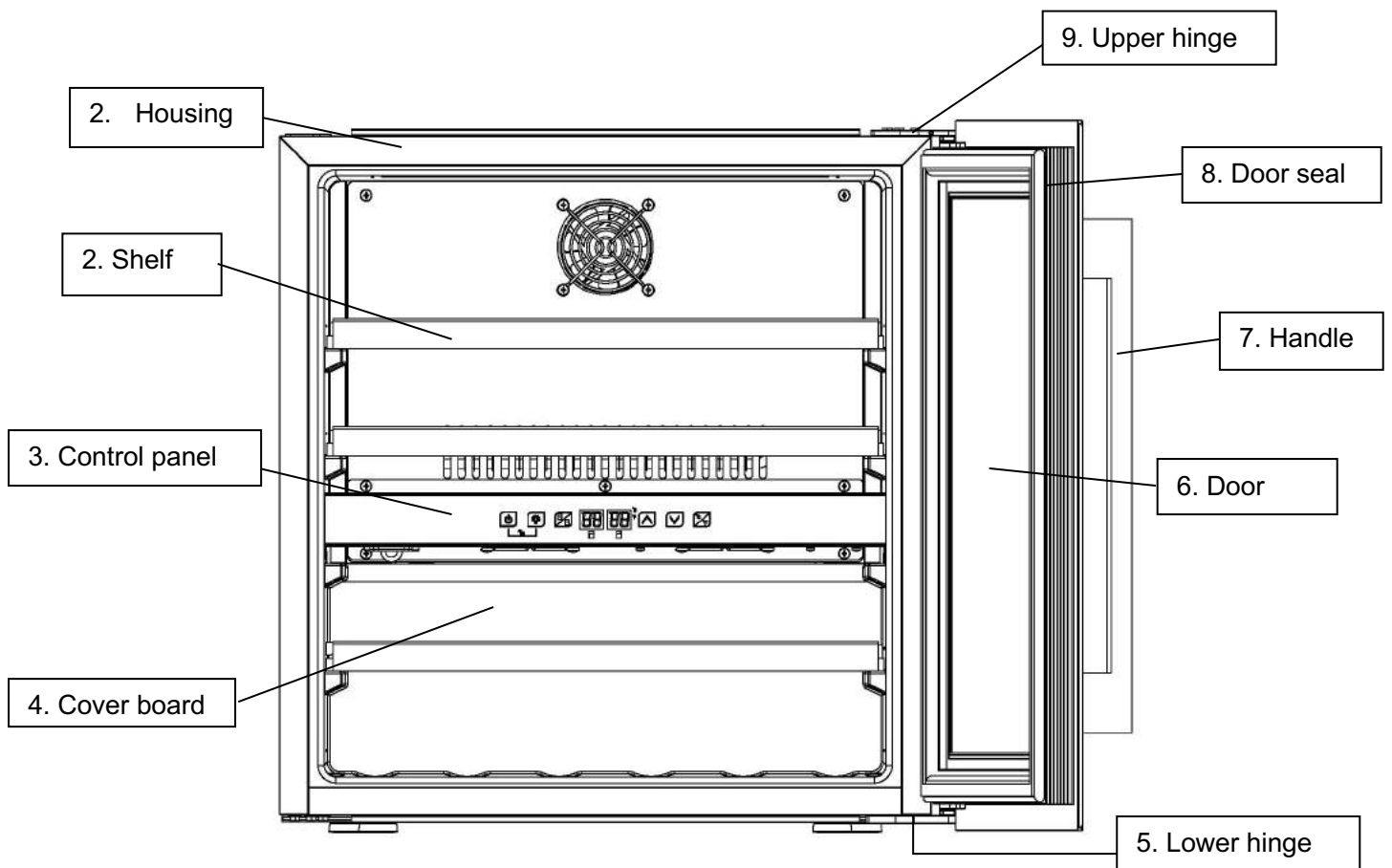

Note: Shelves, door frame, handle and other accessories could be different according to different models and configuration. All photos in this manual are for reference. The appliance you buy might not be exactly the same as shown here. Please refer to the actual product.

Installing the handle and reversing the door of wine cooler

3. Install handle to the door frame of the appliance.

The handle is delivered in a separated package with screws together inside the carton.

- ① Reveal two small holes on the door frame from inner side by pulling out a bit the door seal
- ② Aim the handle to the holes and insert the screws from inside
- ③ Screw them up with screw-driver
- ④ Put back door seal to cover the screws.

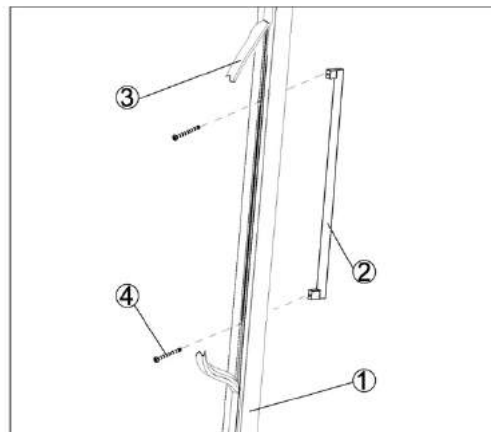

4. Reversing the door

Our wine cooler is delivered with the door opening from left to right. To reverse the opening direction:

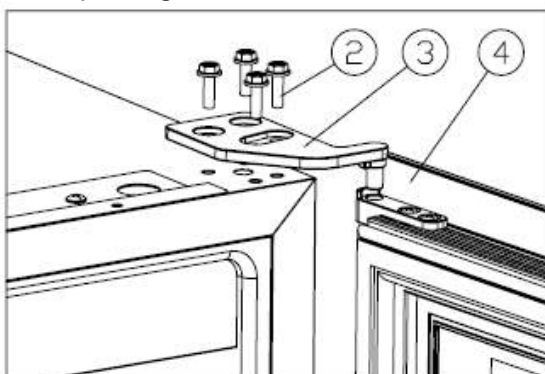

Figure 1

- ✧ Open the door at 90 degrees and keep it steady.
- ✧ Unscrew the M5*16screws(2),dismantle the right upper hinge(3),and remove the door.[Figure 1].

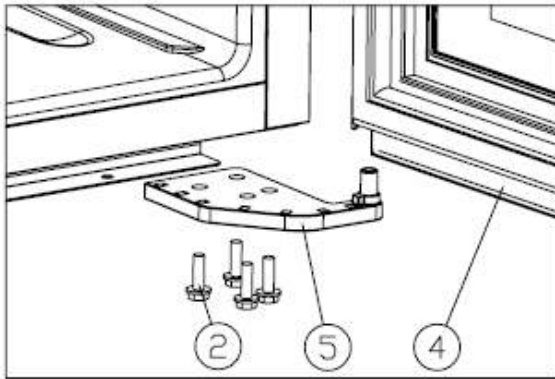

Figure 2

- ✧ Unscrew the M5*16screws②,dismantle the right lower hinge⑤.[Figure 2]

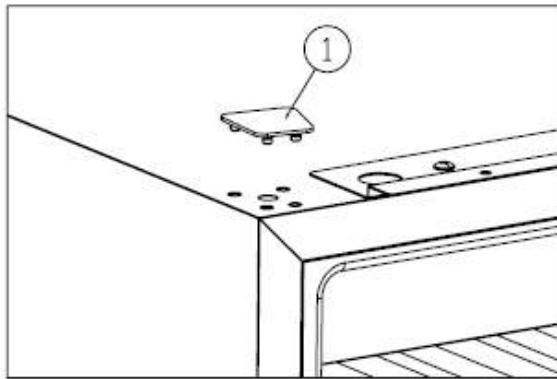

Figure 3

- ✧ Removethegerminal lid①.[Figure 3]

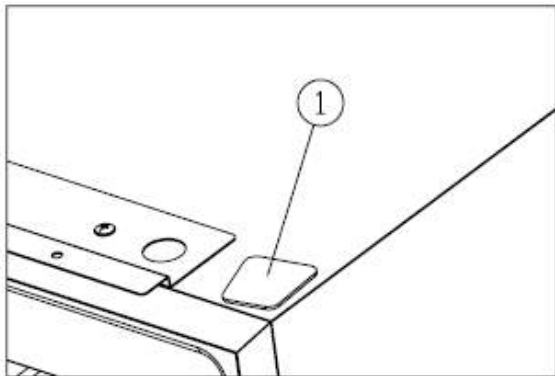

Figure 4

- ✧ Install the germinal lid①.[Figure 4]

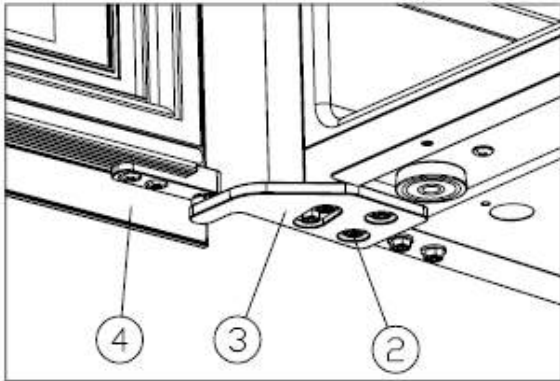

Figure 5

- ✧ Install the right upper hinge (3), and screw tight the M5*16 screws (2). [Figure 5]

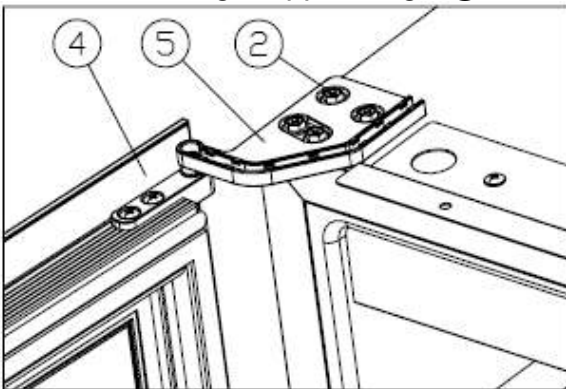

Figure 6

- ✧ Turn the door (4) 180 degrees, and insert the right lower hinge (5), screw tight M5*16 screws (2). [Figure 6] Door reversing is finished.

Operation

Start operation

1. Cleaning the compartment

Before power on, clean inside of the appliance and check the drainage pipe in good connection. (For details, please refer to the "Maintenance and cleaning")

2. Put the appliance still

Before power on in the first time, keep it static at least 30 minutes.

3. Power on

The appliance start operation and it will cool down inside after 1 hour, otherwise you should check the power connection.

Control panel

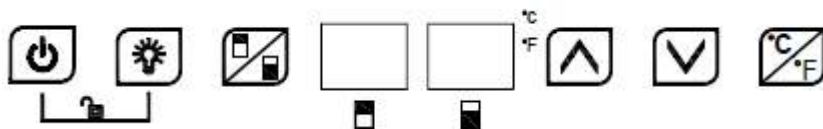

All keys would be invalid in lock mode. Please unlock first.

 **ON/OFF**

1. Keep pressing the key 3 seconds, power down, goes to stand-by mode.
2. Keep pressing the key again 3 seconds to return back to normal working.

 **Light**

Press the key, turn on or turn off the LED lights inside. In stand-by mode, the key is invalid.

 **Zone switch**



Press the key to switch between upper zone and lower zone for choosing which zone to set temperature. Press the key once, the LED display in chosen zone flash regularly. Press up and down key to set temperature. Press the key again; switch the zone to set temperature.

 **UP**

Press the key once, LED Display in regular flash showing current set temperature. Continue pressing to adjust set temperature, one press increase 1°C. Regular flash quit after 5 seconds detecting no press and new set temperature save. LED display return to show actual temperature inside.

 **Down**

Press the key once, LED Display in regular flash showing current set temperature. Continue pressing to adjust set temperature, one press reduce 1°C. Regular flash quit after 5 seconds detecting no press and new set temperature save. LED display return to show actual temperature inside.

  **Child Lock (Combination key)**

1. Lock: Press both keys at the same time for 3 seconds to lock.
2. Unlock: Press both keys at the same time for 3 seconds to unlock.

 **Fahrenheit/Celsius display interchange**

Switch temperature display between Fahrenheit and Celsius by pressing the key.

 **Attention**

4. For both upper and lower zone, the cooling temperature could be set from **5 to 22°C**. And temperature of lower zone could only be set equal to or higher than that of upper zone.
5. Alarm sound: when the system malfunction occur and alarm sound, press any

key on the control panel to cancel the alarm sound.

6. Error code:

When the temperature sensor of upper zone failure occur, error code displays: E1 for open circuit; E2 for short circuit.

When the temperature sensor of Lower zone failure occur, error code displays: E5 for open circuit; E6 for short circuit.

When the defrost sensor failure occur, error code displays: E3 for open circuit; E4 for short circuit.

Wine storage

- ✧ The appliance equips with independent shelf to allow your collection of wine get mature quietly and peacefully.
- ✧ 2+1 wooden shelves loading capacity: **36** bottles. (standard Bordeaux with 750ml)

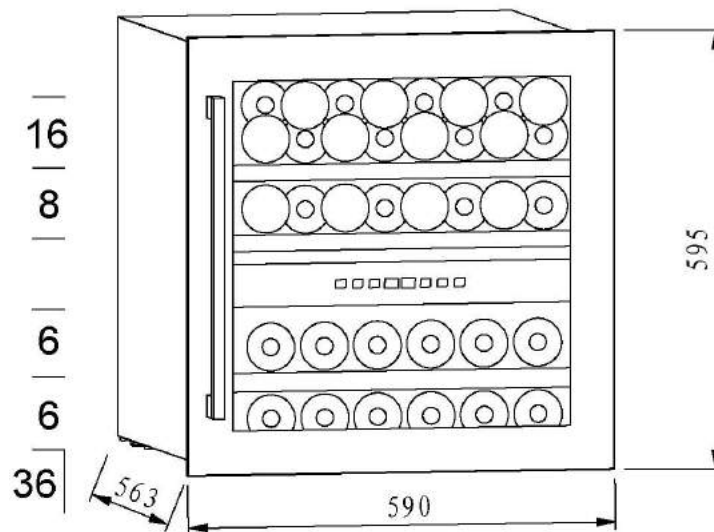

- ✧ Loading capacity will vary in terms of different way of bottle arrangement or different bottle sizes.
- ✧ Each shelf is designed to put on 1 or 2 layers of wine bottles. More than 2 layers of bottle arrangement on one shelf are not recommended.
- ✧ Each shelf could pull out partly to store wine bottles easily.
- ✧ Open the door straight enough before pulling out shelves.
- ✧ If the wine cooler would have no load for a long time, it is recommended to power it off, clean it carefully, and open the door for ventilation.



✧ Below table is the recommended temperature for wine storing & drinking:

Red Wine	15-18°C
White Wine	9-14°C
Rose wine	10-11°C
Champagne & sparkling wine	5- 8°C

Troubleshooting

The appliance makes lots of noise?	<ul style="list-style-type: none"> ● Please adjust the front foot, keep the appliance leveling. ● Please keep the appliance a bit space from walls.
Liquid flowing sound inside the cabinet?	<ul style="list-style-type: none"> ● It is normal because of the refrigerant working inside.
The appliance does not start?	<ul style="list-style-type: none"> ● Make sure the appliance is connected to the power properly. ● Make sure switch on the power. ● The compressor re-starts after 5 minutes for a power cut.
Compressor runs continuously?	<ul style="list-style-type: none"> ● If no cold is being produced, call the after-sale service.
Door does not seal tightly?	<ul style="list-style-type: none"> ● After long time use, the door seal might get stiff & distorted partially. 2. Heat the door seal with hot-wind blower or hot towel. 3. The door seal get softened and close the door.
The appliance does not cool sufficiently?	<ul style="list-style-type: none"> ● Please adjust temperature setting. ● Keep the appliance away from sunlight or heat. ● Please do not open the door frequently if no need.
Unpleasant smells inside cabinet?	<ul style="list-style-type: none"> ● A little bit plastic smell for newly-buy appliance is normal and will disappear after a short time. ● Clean the compartment and ventilate it for a few hours.
Condensate on the glass door?	<ul style="list-style-type: none"> ● Please do not open the door frequently or for a long time. ● Please do not set the temperature too low. ● High ambient temperature and humidity would

	cause condensate.
The light is not working?	<ul style="list-style-type: none"> ● Check the power supply first. ● Call the retailer's after-sale service if the light is broken.

Maintenance and cleaning

Cleaning

- Disconnect the appliance before cleaning.
- Clean the appliance with soft cloth or sponge by water.
- Do not use organic solvents, alkaline detergent, boiling water, washing powder or acid liquid etc.
- Do not flush the compartment of the appliance.
- Clean regularly surfaces that can come in contact with accessible drainage systems.

The below items will damage the surface of wine cooler:

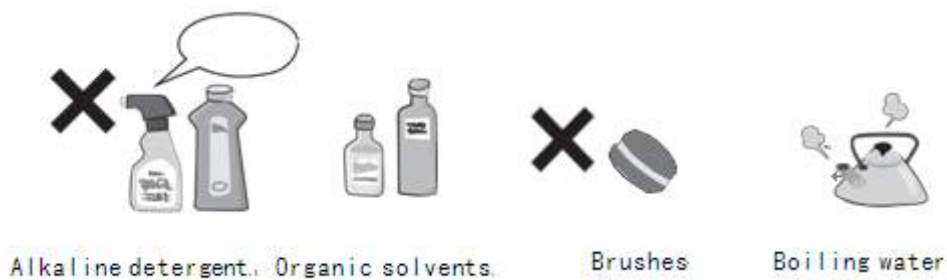

Power cut

Most power cuts could be resolved within a short time. To protect your wines during a power cut, avoid opening the door as much as possible. During very long power cuts, take the necessary measures to protect your wine.

Out of service for long time

Remove all bottles from the appliance, defrost, clean, dry, and leave the door open to prevent mould developing within the appliance.



If the appliance is disconnected or if there is a power cut, you must wait at least five minutes before re-starting.

Moving the appliance

- Cut off the power supply and unplug the appliance.
- Remove all bottles from the appliance.
- When moving the appliance, do not lean the appliance over 45°.



Technical parameters

Product model	CCI92DB
Voltage/frequency	220-240V~/50Hz
Refrigerant/weight	R600a/25g
Effective volume	85 L
Loading capacity	36 bottles
Net weight	34 kg
Unit dimension (WxDxH)	590×563×595mm
Packing dimension (WxDxH)	650×650×655mm

Remarks :

4. The Net weight includes shelves and the Unit dimension is without handle on the door.
5. The manufacturer reserves all the rights to change the above parameters without prior notice. Please refer to the nameplate of your appliance.



6. Loading capacity will vary in terms of different way of bottle arrangement or different bottle sizes (standard Bordeaux with 750ml is applied here).