





# COMPANY

King Shocks, the industry leader for over a decade, continues to leave the competition in the dust by providing the level of quality, consistency and performance that champions demand. Our ongoing product development has led the way long before we opened our doors in 1996. The original designs drawn by Lance King back in the early 80's were created to fill the needs of the top level racers of the day. Nothing existed at the time that could stand up to the punishment dished out by racers like Bill Stroppe, Parnelli Jones and Walker Evans. The faster cars and trucks ran several shocks on each wheel which were often changed at pit stops along with the tires. Our original 3" shock was designed with pure function in mind from only the best quality materials available. King has remained true to that formula to this day.

Every facet of design and manufacturing is continuously refined and then put to the test with winning results from Baja to Dakar. In addition to the quality and innovative design features you will find on all King shocks we provide you with the highest level of customer support. Our depth of knowledge when it comes to shock tuning and suspension set-up is second to none. We are in the dirt on a weekly basis at races, offroad events and tuning sessions helping you attain the most effective performance from your suspension.

Every part we sell is the product of constant testing and development done with top racers in all classes world wide. This real world testing exposes our designs to a level of abuse and destructive forces that cannot be duplicated in a laboratory or on a computer spreadsheet. Our "hands on" experience enables us to make rapid advancements others haven't even dreamed up yet. Racecars have become heavier, faster and more powerful over the years. King's exclusive damping technology and precision componentry have made possible the rapid evolution of offroad suspension design.

Many of the high performance features available today such as bypass tubes, seal technology, shaft diameters and tube construction were pioneered by King's product development team working to give our customers the competitive edge they need. Our understanding of fluid dynamics and piston design alone has created performance levels unlike all others. Nothing rides like a King.

We don't stock "off the shelf" shocks, everything we make is custom made to fit your application from the finest raw materials and billet stock obtainable. You won't find any cast pieces on a King shock, they don't measure up to our demanding standards. All parts used in our products are machined in house right here in the U.S.A. on precision equipment to exacting standards and hand assembled by our technicians. Regardless which of our products you purchase they all contain the latest technology and materials used in our top of the line racing shocks. When you choose to ride on Kings you can rest assured you will have the finest shocks available.



Options 5

Performance Race Series 7

Pure Race Series 15

Monster Truck Shocks 19

Air Shocks 21

Bump Stops 23

OEM Performance Series 25

Toyota 28

Ford 31

Jeep 33

Nissan 35

Chevy / GMC / Hummer 36

UTV Performance Series 37

Kawasaki 39

Polaris 40

Yamaha 41

Arctic Cat 42

King Jack 43

Springs 45

Replacement Parts 47

Warranty 50



# R & D

At King, our ultimate goal is unparalleled performance. We don't count on others to supply us with yesterdays off the shelf technology and we aren't constrained by conventional wisdom. We have already incorporated technology into our shocks that others haven't even dreamed up yet. We seek out the latest advances in materials and processes to maintain our commitment of providing you with the very best. We are constantly working with designers, builders, crew chiefs and drivers to develop the next level of ground breaking advances. This constant interaction with real world conditions allows us firsthand knowledge of how our products perform on a wide array of vehicles and allows us to make rapid progress testing new designs. Our 100% custom made for your application process allows us the flexibility to incorporate improvements rapidly to evolve with our latest advancements and changing conditions.

Bypass shock design, large diameter bodies and shafts, advanced fluid dynamics, seal and wear band efficiency and tight tolerance control have all been developed on a hyper intensive schedule. Our theories and practices are constantly tested in the dirt and on the rocks under race conditions day in and day out.

Unlimited race vehicles have gotten bigger, faster and heavier. Tire sizes and weights continue to expand and horsepower has increased to staggering levels. None of these advancements would be possible without Kings technological breakthroughs in strength, performance and function. This commitment to research and development sets King apart from the competition and goes way beyond what other manufacturers offer.



# SERVICE

King shocks attain unprecedented levels of performance and functionality. Our strict adherence to critical tolerances and our attention to detail combine to create a shock capable of producing real results with even minute adjustments. Convenient regularly scheduled shock servicing can be performed at our facility with minimal turnaround times. Our experienced shock experts can easily spot unusual wear patterns and other anomalies that could lead to reduced performance before they become an issue.

Service procedures include precision honing and polishing of shock cylinders, micro polishing of shafts, seal and wear band replacement, all using original replacement parts and precision processes for a perfect fit. Each factory serviced shock is pressure tested after assembly to verify proper sealing.

If you choose to do your own maintenance all of our shocks are serviceable with our fully stocked rebuild kits that contain all necessary original parts. All Kings are easily adjustable by anyone with simple tools and an understanding of shock construction and valving.

For those of you who wish to take advantage of our depth of knowledge in setting up your new shocks or optimizing your existing set-up we offer weekly in the field shock servicing and tuning. Many teams plan their test sessions around our service schedule and when it comes to race weekend we are there too, in the dirt, where you need us, with our fully stocked support trailer to handle any last minute needs. At King, our service to our customers is second to none.





## KING OPTIONS



**Chrome Cylinder**, available option for all smoothie and bypass shocks.



**Polished or Anodized Reservoir**, available option for all shocks with reservoir.



**Polished or Color Anodized Components**, available option for all King products.



**45 Degree Hose Fitting at End Cap**, available option on all remote reservoir shocks for restrictive mounting location.



**90 Degree Hose Fitting at End Cap**, available option on all remote reservoir shocks for restrictive mounting location.



**45 Degree Hose Fitting at Reservoir**, available option on all remote reservoir shocks for restrictive mounting location.



**90 Degree Hose Fitting at Reservoir**, available option on all remote reservoir shocks for restrictive mounting location.



**45 Degree Piggy Back Mounting**, available option on 2.0 Performance Race Series shocks and coilovers with restrictive reservoir mounting location.



**90 Degree Piggy Back Mounting**, available option on 2.0 & 2.5 Performance Race Series shocks and coilovers with restrictive reservoir mounting location.



**Longer Remote Reservoir Hose**, available option on all remote reservoir shocks



**Black Remote Reservoir Hose**, available option on all remote reservoir shocks



**Stainless Steel Braided Remote Reservoir Hose**, available option on all remote reservoir shocks



**Viton Seals**, seals withstand temperatures up to 450 degrees. Available option on Performance Race series shocks. Standard on all Pure Race Series shocks.



**Compression Adjuster**, available option for 20 positions of adjustability for all piggyback and remote 2.0" & 2.5" Performance Race and Pure Race Series.



**Spherical Bearing Reducers / Spacers**, available to fit 1/2" & 5/8" bolt sizes and 1 1/4" & 1 1/2" mounting tab widths, some metric sizes available .



**Pop-off Rebound Valving**, makes shock a compression dampening only. Available option on all Performance Race and Pure Race Series shocks.



**Additional Bypass Tube**, available option for all bypass shocks.



**Custom Cylinder Length**, available option for all shocks.



**Custom Shaft Length**, available option for all shocks.



**Lighter 3/4" Shock Shaft**, available option for all 2.0 and 2.5 Performance Race Series shocks.



**Rubber Bump**, available option for all Performance Race and Pure Race Series shocks.



**Foam Bump**, available option for all Performance Race and Pure Race Series shocks.



**Longer Rod Ends**, optional available sizes -3/8" (3/4" shaft only), +1/2", +3/4", +1", +2", +3", available option for most Performance Race and Pure Race Series shocks.



**Welded Loop Rod End**, available option for all Performance Race and Pure Race Series shocks.



**Black Coil Slider**, available option for all 2.0 & 2.5 Performance Race Series coil over shocks.



**Billet Nylon Coil Slider**, withstands temperature up to 450 degrees. Available option for all 2.0, 2.5, Performance Race Series coil over shocks. Standard on Pure Race Series coil over shocks.



**Aluminum Coil Slider Cover**, option available in countless colors for all 2.0 & 2.5 Performance Race & Pure Race Series coil over shocks.



**Triple Rate Spring Assembly**, available option for all Performance Race & Pure Race Series coil over shocks.



**Raised Spring Plate**, available option for all Performance Race & Pure Race Series coil over shocks.



**Black King Logos**, available option for all King products.



2.4kt GOLD PLATED SHOCK CYLINDER WITH RED ANODIZED COMPONENTS & RESERVOIR, AND RUBBER BUMP OPTIONS

## KING CUSTOM

At King Shocks "custom" is our normal procedure. If you don't see it, ask for it. Every shock we make is built for your particular application. When you order your shocks, our sales consultants review the information provided on your pre-order form to come up with the basic configuration you will need. They then guide you through the over thirty different options available to come up with the ultimate set of shocks tailored to your vehicle, driving style, and personal preferences. Almost every component on our shocks has a custom option available. Body and shaft lengths and diameters, rod end styles, hose materials and lengths, bump stops, seals, single or dual rate springs and of course custom colors and finishes to make your vehicle stand out from the crowd or blend into the terrain, we even offer camouflage if that is what you desire.

If you can dream it, King can build it. We provide solutions to any damping demands you might have regardless of what you are building or your vehicles intended use. Whether you are restoring a vintage racer, building a monster truck, or in the conceptual stage of a brand new chassis, we have the knowhow and the tools necessary to help you accomplish your goals. Don't let your ideas become compromised by having to run shocks designed for who knows what. King can provide whatever you need to fit your unique design with the ease of adjustment, serviceability and controlled ride quality that we are known for. When it comes time to prove your design in the dirt, King will be there too with our unmatched service and support.

## KING COILPASS

The King, Coilpass shock, is another prime example of King's ability to conceive and build shocks to fit your application no matter what the design parameters are.

The Coilpass shock is used as a primary suspension member to carry the weight of the vehicle and maintain ride height while providing precise adjustability and the high quality ride characteristics King is famous for. It gives you the same performance as a traditional dual shock set-up but with greater simplicity and less weight. The Coilpass also conforms to single shock per wheel rules mandated in certain racing classes.

The King Coilpass may look exotic but it uses the same time tested components as the rest of our shock line. This unique design can be built in a dual piston configuration offering both velocity and position sensitive damping. You get all the function of dual shocks in one package. Let King's engineering prowess and depth of knowledge provide creative solutions to your suspension design challenges. Nothing rides like a King.







**RHYSMILLEN**  
RED BULL EXPERIMENT - NEW YEARS EVE



PERFORMANCE RACE SERIES 2.5"x 12" COIL OVER WITH REMOTE RESERVIOR

## PERFORMANCE RACE SERIES

King's Performance Race series shocks are brimming with technological breakthroughs conceived during strenuous testing in the harshest environments. Utilizing only the highest quality materials and strict precision tolerances they deliver unparalleled performance. Our understanding of fluid dynamics and piston design has created unmatched levels of ride quality and superior control.

We offer a wide range of shock types and configurations such as bypass shocks, coilovers, smooth bodies with reservoir, or pure emulsion. Our shocks don't sit on a shelf looking for a home but instead are 100% custom made for your application. All our shocks are easily tunable with simple tools to provide the level of damping you need.

When you choose to ride on Kings you can rest assured you will have the finest shocks available. A set of King, Performance Race series shocks, are all you need to make your suspension perform to its full potential.

100% made in the USA under the strictest tolerances from the highest quality materials obtainable. Easily tunable and serviceable with simple hand tools.

High quality fittings are mated to Aeroquip high pressure hoses, when remote reservoirs are used, which resist abrasion and allow a tighter bend radius without kinking like braided stainless or cloth lines do.

Lightweight hard anodized 6063 aluminum alloy reservoirs dissipate heat quickly and will not rust due to gas charging contamination.

Shock cylinders are precision bored to within +/- .001, then honed after cadmium plating to remove buildup for a tight piston seal and optimum valving function. Coilover shocks are machined with our own truncated thread design for ultimate strength and trouble free spring adjustments.

The heat treated 6061 aluminum alloy piston has our highly developed port configurations that contribute to the famous king damping performance.

Heat treated stainless alloy valve shims have a unique grain structure that does not fracture and remains stable at high temperatures.

Wear bands are made from an exclusive Rulon composite that wears longer than any other material available.

Large 3/4" or 7/8" diameter shafts have a minimum tensile strength of 100,000 pounds per square inch. They are hard chromed and micro-polished to a 6 RA finish for extended seal life.

Aluminum components are machined from aircraft quality billet.

Steel, Teflon lined, spherical bearings for smooth articulation and long life with no metal to metal contact.

### STANDARD STROKE LENGTHS

2.0 STROKE		2.5 STROKE		3.0 STROKE	
COMP	EXT	COMP	EXT	COMP	EXT
6"	13	6"	14	8"	16
8"	15	8"	16	10"	18.375
10"	17.05	10"	18.375	12"	20.65
12"	19.585	12"	20.65	14"	23.25
14"	21.585	14"	23.25	16"	26
16"	23.6	16"	26	18"	28
	39.5	18"	28		46

\*CUSTOM LENGTHS AVAILABLE



STEERING STABILIZER  
PERFORMANCE RACE "PR"



SMOOTHIE PIGGYBACK RESERVOIR  
PERFORMANCE RACE "PR"

2.0 DIAMETER		2.5 DIAMETER	
6"	PR2006-SSPB	6"	PR2506-SSPB
8"	PR2008-SSPB	8"	PR2508-SSPB
10"	PR2010-SSPB	10"	PR2510-SSPB
12"	PR2012-SSPB	12"	PR2512-SSPB
14"	PR2014-SSPB	14"	PR2514-SSPB
16"	PR2016-SSPB	16"	PR2516-SSPB



SMOOTHIE EMULSION  
PERFORMANCE RACE "PR"

2.0 DIAMETER		2.5 DIAMETER	
6"	PR2006-SSNR	6"	PR2506-SSNR
8"	PR2008-SSNR	8"	PR2508-SSNR
10"	PR2010-SSNR	8"	PR2510-SSNR
12"	PR2012-SSNR	10"	PR2512-SSNR
14"	PR2014-SSNR	12"	PR2514-SSNR
16"	PR2016-SSNR	14"	PR2516-SSNR
		18"	PR2518-SSNR

2.0 DIAMETER		2.5 DIAMETER	
6"	PR2006-STNR	8"	PR2508-STNR
8"	PR2008-STNR	10"	PR2510-STNR
10"	PR2010-STNR	12"	PR2512-STNR
12"	PR2012-STNR		



SMOOTHIE REMOTE RESERVOIR  
PERFORMANCE RACE "PR"

2.0 DIAMETER		2.5 DIAMETER		3.0 DIAMETER	
6"	PR2006-SS	6"	PR2506-SS	8"	PR3008-SS
8"	PR2008-SS	8"	PR2508-SS	10"	PR3010-SS
10"	PR2010-SS	10"	PR2510-SS	12"	PR3012-SS
12"	PR2012-SS	12"	PR2512-SS	14"	PR3014-SS
14"	PR2014-SS	14"	PR2514-SS	16"	PR3016-SS
16"	PR2016-SS	16"	PR2516-SS	18"	PR3018-SS
		18"	PR2518-SS		

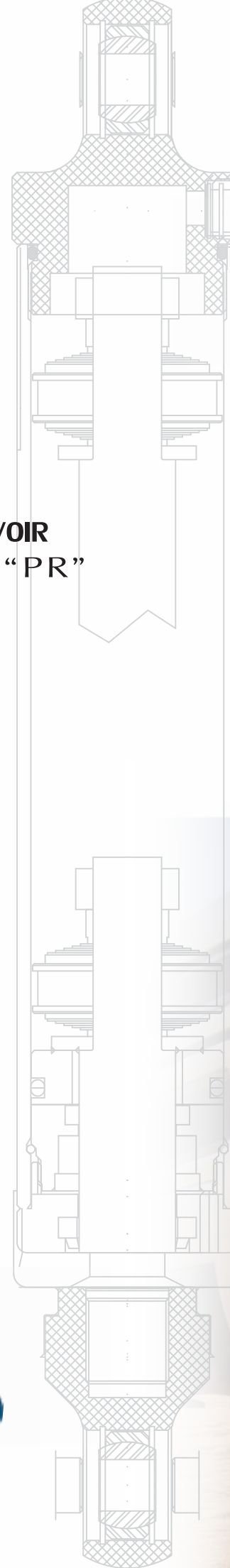

\*OPTIONS SHOWN: ANODIZED BLACK COMPONENTS, BLACK HOSE, CHROME SHOCK BODY, POLISHED RESERVOIR, AND RESERVOIR BRACKET.





**CASEYMEARS**  
NASCAR SPRINT CUP SERIES DRIVER

\*SHOWN OPTIONS: ANODIZED BLACK COMPONENTS & RESERVOIR, BLACK HOSE, CHROME SHOCK BODY, BLACK COIL SPACER, AND CUSTOMER POWDER COATED BLACK SPRINGS



3 TUBE BYPASS SHOWN,  
2-5 TUBE CONFIGURATIONS AVAILABLE

**BYPASS REMOTE RESERVOIR  
PERFORMANCE RACE "PR"**

2.0 DIAMETER	2.5 DIAMETER	3.0 DIAMETER
2 TUBE BYPASS	2 TUBE BYPASS	2 TUBE BYPASS
6" PR2006-BP2H	6" PR2506-BP2H	8" PR3008-BP2H
8" PR2008-BP2H	8" PR2508-BP2H	10" PR3010-BP2H
10" PR2010-BP2H	10" PR2510-BP2H	12" PR3012-BP2H
12" PR2012-BP2H	12" PR2512-BP2H	14" PR3014-PB2H
14" PR2014-BP2H	14" PR2514-BP2H	16" PR3016-BP2H
16" PR2016-BP2H	16" PR2516-BP2H	18" PR3018-BP2H
3 TUBE BYPASS	3 TUBE BYPASS	3 TUBE BYPASS
6" PR2006-BP3H	6" PR2506-BP3H	8" PR3008-BP3H
8" PR2008-BP3H	8" PR2508-BP3H	10" PR3010-BP3H
10" PR2010-BP3H	10" PR2510-BP3H	12" PR3012-BP3H
12" PR2012-BP3H	12" PR2512-BP3H	14" PR3014-BP3H
14" PR2014-BP3H	14" PR2514-BP3H	16" PR3016-BP3H
16" PR2016-BP3H	16" PR2516-BP3H	18" PR3018-BP3H



2 TUBE BYPASS SHOWN,  
2-5 TUBE CONFIGURATIONS AVAILABLE

**BYPASS PIGGYBACK RESERVOIR  
PERFORMANCE RACE "PR"**

2.0 DIAMETER	2.5 DIAMETER	3.0 DIAMETER
2 TUBE BYPASS	2 TUBE BYPASS	2 TUBE BYPASS
6" PR2006-BP2P	6" PR2506-BP2P	8" PR3008-BP2P
8" PR2008-BP2P	8" PR2508-BP2P	10" PR3010-BP2P
10" PR2010-BP2P	10" PR2510-BP2P	12" PR3012-BP2P
12" PR2012-BP2P	12" PR2512-BP2P	14" PR3014-PB2P
14" PR2014-BP2P	14" PR2514-BP2P	16" PR3016-BP2P
16" PR2016-BP2P	16" PR2516-BP2P	18" PR3018-BP2P
3 TUBE BYPASS	3 TUBE BYPASS	3 TUBE BYPASS
6" PR2006-BP3P	6" PR2506-BP3P	8" PR3008-BP3P
8" PR2008-BP3P	8" PR2508-BP3P	10" PR3010-BP3P
10" PR2010-BP3P	10" PR2510-BP3P	12" PR3012-BP3P
12" PR2012-BP3P	12" PR2512-BP3P	14" PR3014-BP3P
14" PR2014-BP3P	14" PR2514-BP3P	16" PR3016-BP3P
16" PR2016-BP3P	16" PR2516-BP3P	18" PR3018-BP3P

-STANDARD STROKE LENGTHS ON PAGE 8 \*CUSTOM LENGTHS AVAILABLE



**COIL OVER EMULSION  
PERFORMANCE RACE "PR"**

2.0 DIAMETER		2.5 DIAMETER	
6"	PR2006-CNRS	6"	PR2506-CNRS
8"	PR2008-CNRS	8"	PR2508-CNRS
10"	PR2010-CNRS	10"	PR2510-CNRS
12"	PR2012-CNRS	12"	PR2512-CNRS
14"	PR2014-CNRS	14"	PR2514-CNRS
16"	PR2016-CNRS	16"	PR2516-CNRS
		18"	PR2518-CNRS

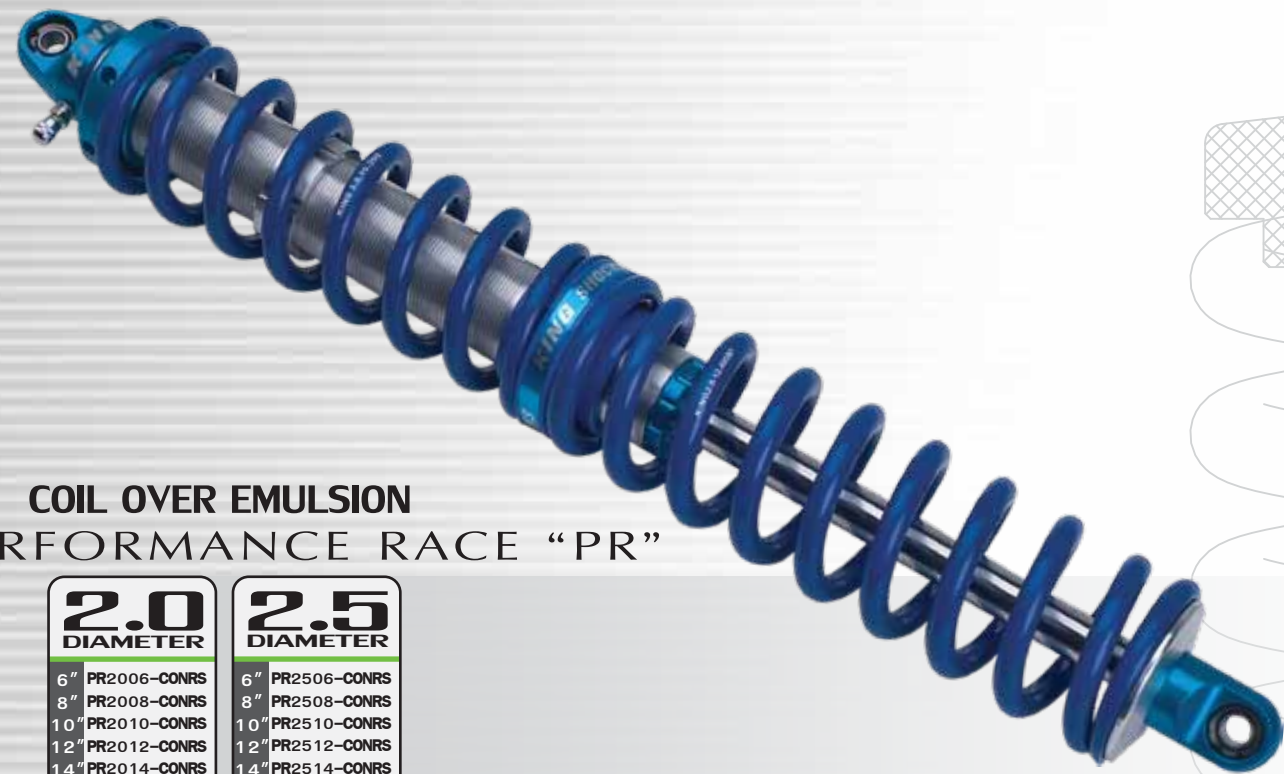

**COIL OVER PIGGYBACK RESERVOIR  
PERFORMANCE RACE "PR"**

2.0 DIAMETER		2.5 DIAMETER	
6"	PR2006-COPBS	6"	PR2506-COPBS
8"	PR2008-COPBS	8"	PR2508-COPBS
10"	PR2010-COPBS	10"	PR2510-COPBS
12"	PR2012-COPBS	12"	PR2512-COPBS
14"	PR2014-COPBS	14"	PR2514-COPBS
16"	PR2016-COPBS	16"	PR2516-COPBS
		18"	PR2518-COPBS



**COIL OVER REMOTE RESERVOIR  
PERFORMANCE RACE "PR"**

2.0 DIAMETER		2.5 DIAMETER		3.0 DIAMETER	
6"	PR2006-COHS	6"	PR2506-COHS	8"	PR3008-COHS
8"	PR2008-COHS	8"	PR2508-COHS	10"	PR3010-COHS
10"	PR2010-COHS	10"	PR2510-COHS	12"	PR3012-COHS
12"	PR2012-COHS	12"	PR2512-COHS	14"	PR3014-COHS
14"	PR2014-COHS	14"	PR2514-COHS	16"	PR3016-COHS
16"	PR2016-COHS	16"	PR2516-COHS	18"	PR3018-COHS
		18"	PR2518-COHS		

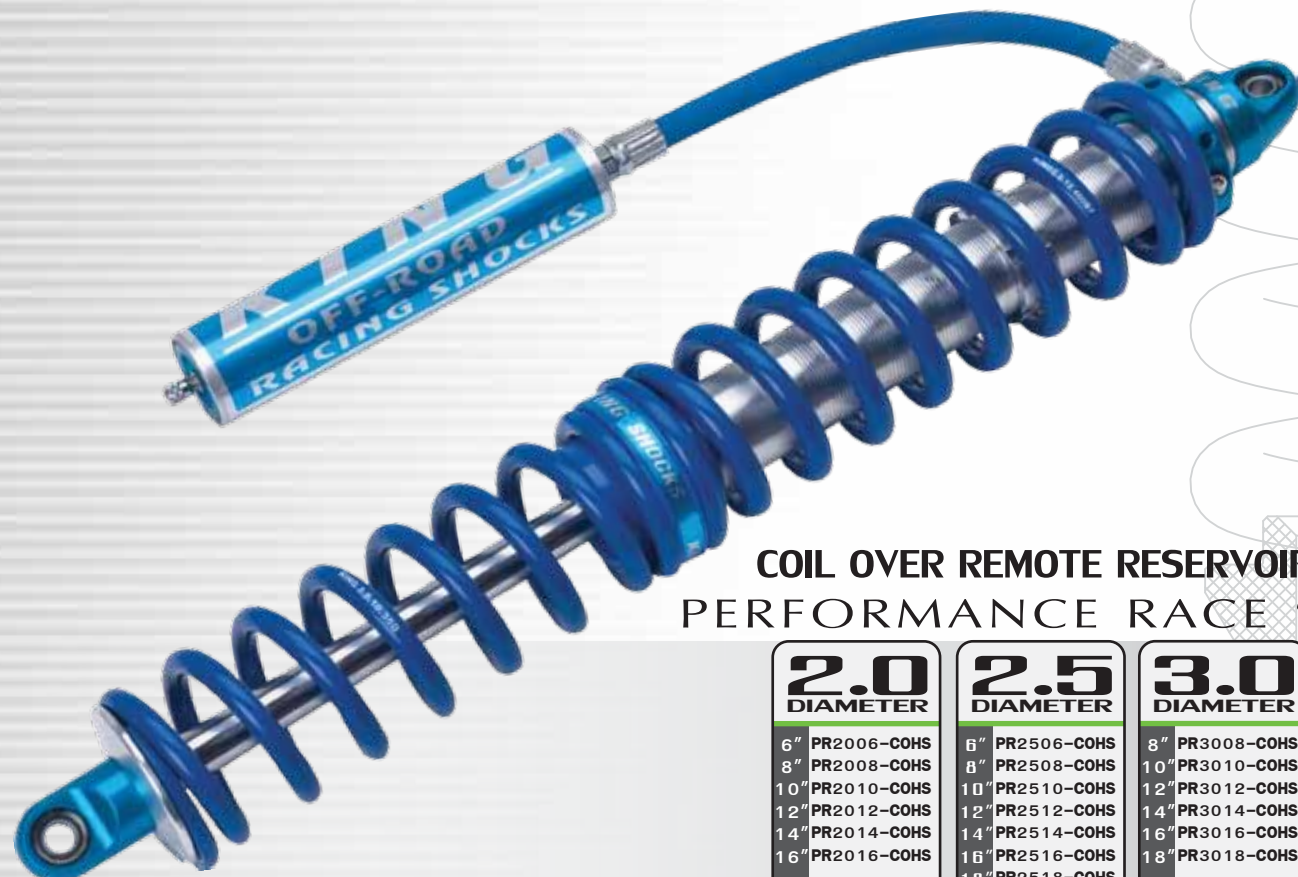

**COIL CARRIER  
PERFORMANCE RACE "PR"**

2.0 DIAMETER		2.5 DIAMETER	
6"	PR2006-CCNRS	6"	PR2506-CCNRS
8"	PR2008-CCNRS	8"	PR2508-CCNRS
10"	PR2010-CCNRS	10"	PR2510-CCNRS
12"	PR2012-CCNRS	12"	PR2512-CCNRS
14"	PR2014-CCNRS	14"	PR2514-CCNRS
16"	PR2016-CCNRS	16"	PR2516-CCNRS
		18"	PR2518-CCNRS



SHOWN WITHOUT SPRINGS



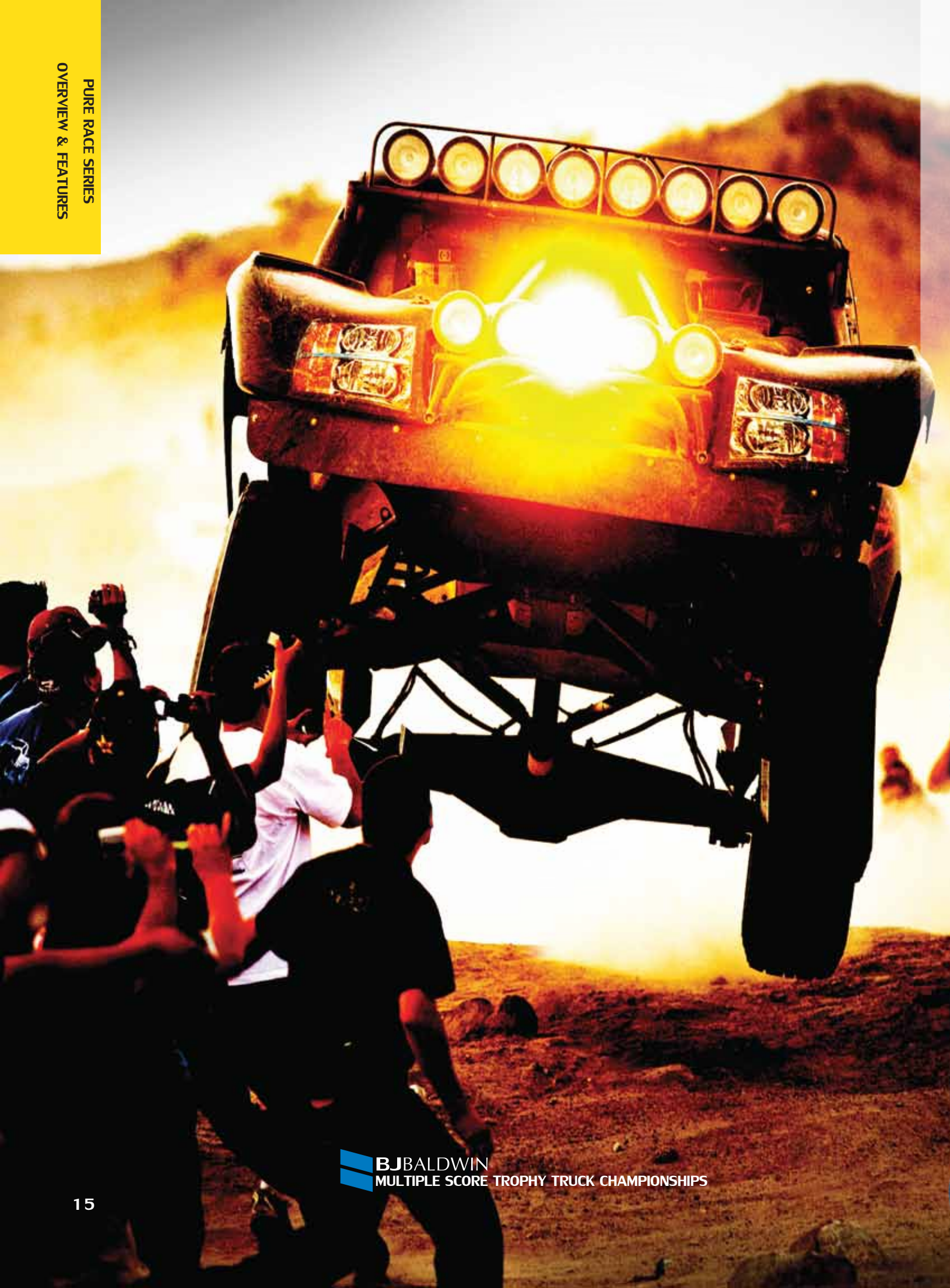

**BJBALDWIN**  
MULTIPLE SCORE TROPHY TRUCK CHAMPIONSHIPS



RACE SERIES 4.0" x 1.6" B TUBE BYPASS WITH PIGGYBACK RESERVIOR

## PURE RACE SERIES

King's Pure Race Series shocks represent the highest level of race shock development; they are designed with one purpose in mind, all out racing. Our constant process of research and development has allowed us to dominate in the toughest races on the planet like the legendary Baja 1000 and the Dakar Rally.

The Pure Race series have unique materials and design features to withstand blistering temperatures up to 450 degrees and the immense forces encountered by the fastest competition only vehicles. Every aspect of these shocks has been optimized to deliver brute strength, unparalleled performance and precision adjustability. King Pure Race series shocks deliver the control you need whether you are floating through the whoops in a high strung screamer or pushing the dirt in your big bore heavyweight. If your goal is to dominate the competition you need to experience the level of control a set of Kings will provide.

100% made in the USA under the strictest tolerances from the highest quality materials obtainable. Easily tunable and serviceable with simple hand tools.

- Shock cylinders are precision bored to within +/- .001, then honed after cadmium plating to remove buildup for a tight piston seal and optimum valving function. Coilover shocks are machined with our own truncated thread design for ultimate strength and trouble free spring adjustments.
- Lightweight hard anodized 6063 aluminum alloy reservoirs dissipate heat quickly and will not rust due to gas charging contamination. Threaded end caps withstand high pressures and ease in maintenance.
- O-ring Schrader cover that mounts to the cap, not the valve itself, creates a positive seal and keeps dirt and moisture out.
- The heat treated 2024 aluminum alloy piston has our highly developed port configurations that contribute to the unique damping performance.
- Heat treated stainless alloy valve shims have a unique grain structure that does not fracture and remains stable at high temperatures to maintain consistent valve function.
- Wear bands are made from an exclusive Teflon bronze composite that wears longer than any other material available.
- Viton rod seals withstand temps up to 450 degrees. Wiper seals are machined with diamond tooling from a high temperature resistant carbon composite material.
- Large diameter shafts are induction heat treated, hard chromed and micro polished to a mirror finish. The 58-62 Rockwell hardness and 100,000 psi tensile strength shafts require expensive, specialized machining operations but the additional effort eliminates rock damage and creates a superior sealing surface.
- Aluminum components are machined from aircraft quality billet.

## STANDARD STROKE LENGTHS

ALL STROKE		
	COMP	EXT
8"	17.81	25.81
10"	19.81	29.81
12"	21.81	33.81
14"	24.56	38.56
16"	27.31	43.06
18"	30.06	48.06
20"	32.06	52.06
26"	38.06	64.06

\*CUSTOM LENGTHS AVAILABLE



### BYPASS PIGGYBACK RESERVOIR PURE RACE SERIES

2.5 DIAMETER		3.0 DIAMETER		4.0 DIAMETER	
<b>2 TUBE BYPASS</b>		<b>3 TUBE BYPASS</b>		<b>5 TUBE BYPASS</b>	
8"	RS2508-BP2P	8"	RS3008-BP3P	10"	RS4010-BP5P
10"	RS2510-BP2P	10"	RS3010-BP3P	12"	RS4012-BP5P
12"	RS2512-BP2P	12"	RS3012-BP3P	14"	RS4014-BP5P
14"	RS2514-BP2P	14"	RS3014-BP3P	16"	RS4016-BP5P
16"	RS2516-BP2P	16"	RS3016-BP3P	18"	RS4018-BP5P
18"	RS2518-BP2P	18"	RS3018-BP3P	20"	RS4020-BP5P
<b>3 TUBE BYPASS</b>		<b>5 TUBE BYPASS</b>		<b>6 TUBE BYPASS</b>	
8"	RS2508-BP3P	10"	RS4010-BP6P	10"	RS4010-BP6P
10"	RS2510-BP3P	12"	RS4012-BP6P	12"	RS4012-BP6P
12"	RS2512-BP3P	14"	RS4014-BP6P	14"	RS4014-BP6P
14"	RS2514-BP3P	16"	RS4016-BP6P	16"	RS4016-BP6P
16"	RS2516-BP3P	18"	RS4018-BP6P	18"	RS4018-BP6P
18"	RS2518-BP3P	20"	RS4020-BP6P	20"	RS4020-BP6P
		26"	RS4026-BP6P	26"	RS4026-BP6P



### WHY PURE RACE SERIES?

King, Pure Race series bypass and coil over shocks are built to exacting standards with one thing in mind; performance above all else. Bypass shock tubes are made from 4130 Chromoly material. The bypass ports are cnc drilled then hand de-burred and polished. The bypass tubes are beautifully tig welded in their designated locations before the completed assemblies are pressure tested to 300 psi. The welded and plated bodies are then precision bored to +/- .001 of an inch before honing. The ports consist of an array of smaller holes to help maintain piston seal. The piston slides over the fluid passages without scuffing the wear band or seals. The port openings are meticulously flow matched to the bypass tubes to provide unrestricted fluid flow to the valves. Tube locations are determined using your vehicle specifics and our knowledge base accumulated through years of testing. They are designed as a left and right and come with your choice of reservoir mounting options to fit your chassis like a glove.

King bypass valves are built to critical tolerances using high-temp 17-4 stainless steel alloy. Our adjusters offer a level of functional adjustability that is unmatched. The first turn of the high strength heat treated adjusting screw offers the same precise metering as the last. Each bypass stage is separately tunable, position sensitive and operates independently from the others. King's cold drawn 2024 billet aluminum piston design incorporates our deep understanding of fluid dynamics and precision machining abilities. The gapless, Teflon impregnated bronze wear band is pre-loaded in the piston groove with a Viton o-ring so it fits tightly into the bore and creates a double seal. This optimizes valving function and on the bypass shock seals so well that it allows the final compression stage to be used as a hydraulic bump stop. King bypass and coil over shocks contain stainless alloy heat treated valve shims that remain stable at high temperatures to maintain consistent damping and avoid fatigue cracks like carbon steel shims.

King Pure Race coil over shock bodies are machined with our own truncated thread design to produce ultimate strength and trouble free spring adjustments. Our three piece adjusting nut assembly has a unique pinch bolt design that offers superior clamping force to retain your coil preload adjustments without crushing the threads like set screw style collars do. It also includes an upper spring centering ring and nylon antifricition disc to make quick work of adjusting even the heaviest springs under substantial preload. Our machined billet nylon coil sliders maintain proper spring alignment and silent operation while withstanding temperatures up to 450 degrees. Progressive dual rate spring applications use a set of lockable secondary nuts threaded onto the body to allow precise adjustment of secondary spring engagement.

### BYPASS REMOTE RESERVOIR PURE RACE SERIES

2.5 DIAMETER		3.0 DIAMETER		4.0 DIAMETER	
<b>2 TUBE BYPASS</b>		<b>3 TUBE BYPASS</b>		<b>5 TUBE BYPASS</b>	
8"	RS2508-BP2H	8"	RS3008-BP3H	10"	RS4010-BP5H
10"	RS2510-BP2H	10"	RS3010-BP3H	12"	RS4012-BP5H
12"	RS2512-BP2H	12"	RS3012-BP3H	14"	RS4014-BP5H
14"	RS2514-BP2H	14"	RS3014-BP3H	16"	RS4016-BP5H
16"	RS2516-BP2H	16"	RS3016-BP3H	18"	RS4018-BP5H
18"	RS2518-BP2H	18"	RS3018-BP3H	20"	RS4020-BP5H
<b>3 TUBE BYPASS</b>		<b>5 TUBE BYPASS</b>		<b>6 TUBE BYPASS</b>	
8"	RS2508-BP3H	10"	RS4010-BP6H	10"	RS4010-BP6H
10"	RS2510-BP3H	12"	RS4012-BP6H	12"	RS4012-BP6H
12"	RS2512-BP3H	14"	RS4014-BP6H	14"	RS4014-BP6H
14"	RS2514-BP3H	16"	RS4016-BP6H	16"	RS4016-BP6H
16"	RS2516-BP3H	18"	RS4018-BP6H	18"	RS4018-BP6H
18"	RS2518-BP3H	20"	RS4020-BP6H	20"	RS4020-BP6H
		26"	RS4026-BP6H	26"	RS4026-BP6H

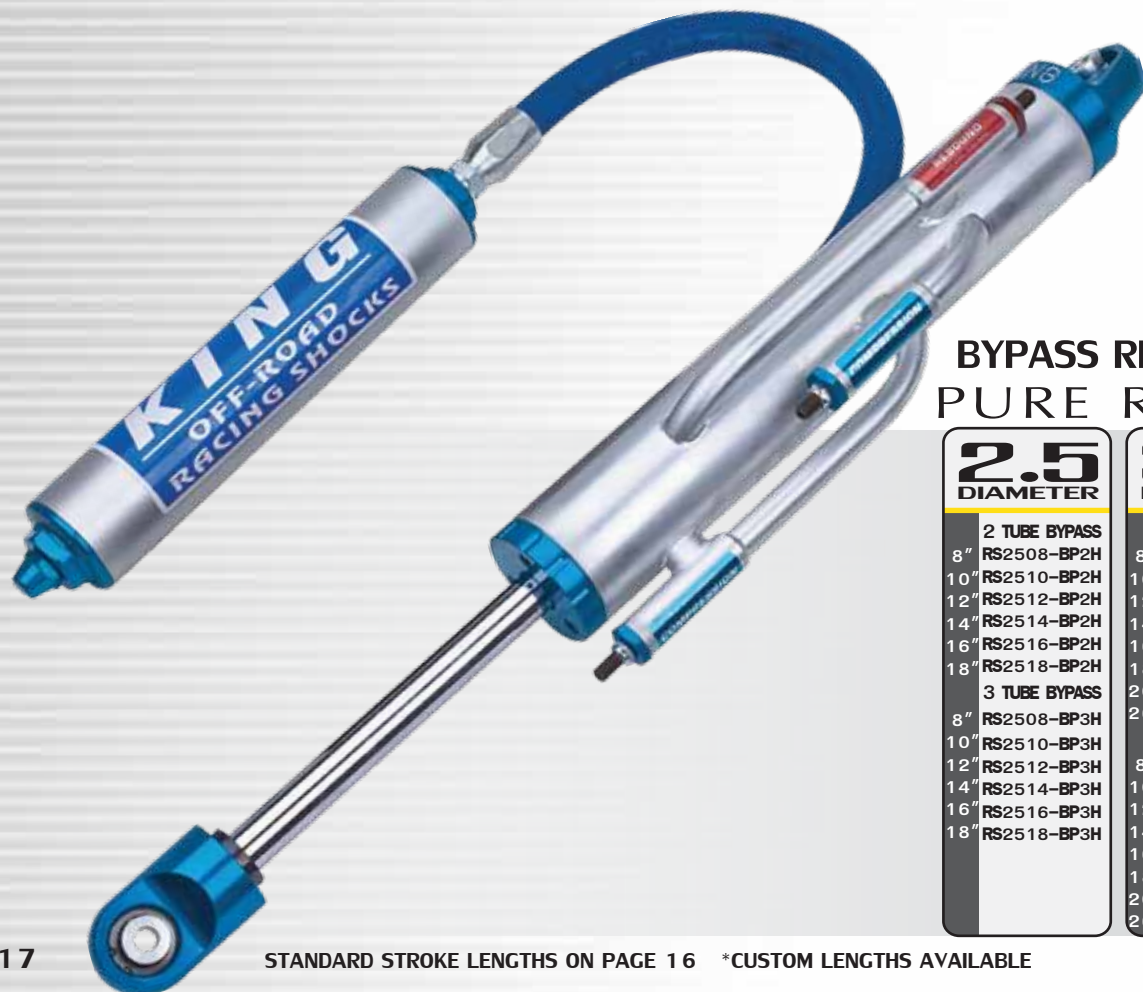

### COIL OVER REMOTE RESERVOIR PURE RACE SERIES

2.0 DIAMETER		2.5 DIAMETER		3.0 DIAMETER	
8"	RS2008-COS	8"	RS2508-COS	8"	RS3008-COS
10"	RS2010-COS	10"	RS2510-COS	10"	RS3010-COS
12"	RS2012-COS	12"	RS2512-COS	12"	RS3012-COS
14"	RS2014-COS	14"	RS2514-COS	14"	RS3014-COS
		16"	RS2516-COS	16"	RS3016-COS
				18"	RS3018-COS
				20"	RS3020-COS
				26"	RS3026-COS



Springs twist during extension and compression. The King 3 Piece coil nut allows the springs natural rotation without binding.

### COIL CARRIER PURE RACE SERIES

2.0 DIAMETER		2.5 DIAMETER	
8"	RS2008-CCS	8"	RS2508-CCS
10"	RS2010-CCS	10"	RS2510-CCS
12"	RS2012-CCS	12"	RS2512-CCS
14"	RS2014-CCS	14"	RS2514-CCS
16"	RS2016-CCS	16"	RS2516-CCS

COIL OVER REMOTE RESERVOIR SHOWN  
COIL SPRINGS SOLD SEPARATELY





## MONSTER TRUCK SHOCKS

King Shocks is the leader when it comes to custom design and engineering. King air springs, coilovers and bypass shocks for Monster Trucks contain the same proven technology constantly being developed in brutal competition from stadiums across America to Baja and Dakar. Monster Trucks have evolved from merely a spectacle, performing slow speed car crushing, into highly engineered, competitive race trucks.

The unique demands placed on Monster Truck suspensions in competition require the highest level of damping performance and brute strength that only King custom shocks provide. King's constant progression in damping function, quality of materials and ultimate strength of components make us the natural choice if your goal is to dominate the competition. King's easily serviceable and tunable designs give you the adjustability you need to maintain your competitive edge and if needed, our tuning expertise is only a phone call or email away. Once you experience the performance and ride quality of King Shocks you will know there really is a difference. Nothing rides like a King.

### AIR SPRINGS

**3.0 DIAMETER**

18"	RS3018-AS
20"	RS3020-AS
26"	RS3026-AS



### BYPASS

3.0 DIAMETER		4.0 DIAMETER	
4 TUBE BYPASS		4 TUBE BYPASS	
18"	RS3018-BP4P	18"	RS4018-BP4P
20"	RS3020-BP4P	20"	RS4020-BP4P
26"	RS3026-BP4P	26"	RS4026-BP4P
5 TUBE BYPASS		5 TUBE BYPASS	
18"	RS3018-BP5P	18"	RS4018-BP5P
20"	RS3020-BP5P	20"	RS4020-BP5P
26"	RS3026-BP5P	26"	RS4026-BP5P



### COIL OVER

**3.0 DIAMETER**

18"	RS3018-COS
20"	RS3020-COS
26"	RS3026-COS





## SMOOTHIE AIRSHOCK AIR SHOCK SERIES

2.0 DIAMETER		2.5 DIAMETER	
6"	PR2006-ASNR	6"	PR2506-ASNR
8"	PR2008-ASNR	8"	PR2508-ASNR
10"	PR2010-ASNR	10"	PR2510-ASNR
12"	PR2012-ASNR	12"	PR2512-ASNR
14"	PR2014-ASNR	14"	PR2514-ASNR
16"	PR2016-ASNR	16"	PR2516-ASNR
		18"	PR2518-ASNR

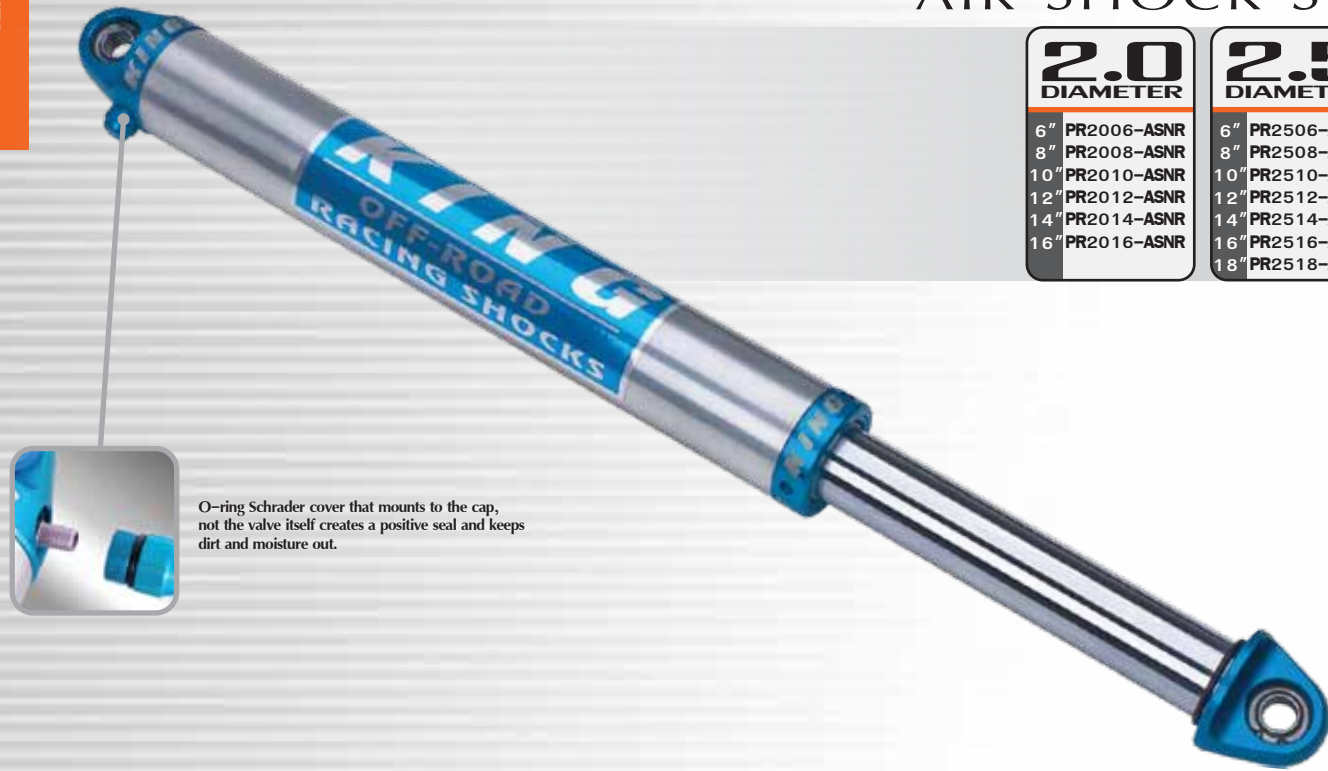

O-ring Schrader cover that mounts to the cap, not the valve itself creates a positive seal and keeps dirt and moisture out.



**TRACY JORDAN**  
MULTI-TIME ROCK CRAWLING CHAMPION

## AIR SHOCK SERIES

Air shocks have been around for a long time. King's quality materials, unique design features and precise tolerances are what set our air shocks apart. King air shocks offer infinite height and pressure settings in addition to our easily adjustable valving. Tubular, hard chromed shafts further reduce the weight and urethane seals insure proper sealing and long life. The quality of our internal sealing allows you to set-up your air shock to also function as a bumpstop if needed.

King's air bypass shock provides the features of our air shock with the position sensitive damping control of our bypass design. This shock is a prime example of King's custom built for your application approach. If you don't see it, ask for it. Once you experience King shocks you will know there really is a difference. Nothing rides like a King.

100% made in the USA under the strictest tolerances from the highest quality materials obtainable. Easily tunable and serviceable with simple hand tools.

O-ring Schrader cover that mounts to the cap, not the valve itself creates a positive seal and keeps dirt and moisture out. Not available on air bypass.

Shock cylinders are precision bored to within +/- .001, then honed after cadmium plating to remove buildup for a tight piston seal and optimum valving function.

Aluminum components are machined from aircraft quality billet.

The heat treated 6061 aluminum alloy piston has our highly developed port configurations that contribute to the unique damping performance and famous King ride quality.

Heat treated stainless alloy valve shims have a unique grain structure that does not fracture and remains stable at high temperatures to maintain consistent valve function.

Wear bands are made from an exclusive Teflon bronze composite that wears longer than any other material available. The same material is used on beds and ways of precision cnc machines.

Large 1-1/4" or 1-5/8" diameter shafts have a minimum tensile strength of 75,000 pounds per square inch. They are hard chromed and micro-polished to a 6 RA finish for extended seal life.

Steel Teflon lined spherical bearings for smooth articulation and long life with no metal to metal contact.



## BYPASS AIR SHOCK AIR SHOCK SERIES

2.0 DIAMETER		2.5 DIAMETER	
3 TUBE BYPASS		3 TUBE BYPASS	
8"	PR2008-AS3T	8"	PR2508-AS3T
10"	PR2010-AS3T	10"	PR2510-AS3T
12"	PR2012-AS3T	12"	PR2512-AS3T
14"	PR2014-AS3T	14"	PR2514-AS3T
16"	PR2016-AS3T	16"	PR2516-AS3T
		18"	PR2518-AS3T

## STANDARD STROKE LENGTHS

STROKE	2.0		2.5	
	COMP	EXT	COMP	EXT
6"	14.17	20.17	14.60	20.60
8"	16.17	24.17	16.60	24.60
10"	18.17	28.17	19.10	29.10
12"	20.67	32.67	21.10	33.10
14"	22.67	36.67	23.03	37.03
16"	24.67	40.67	25.78	40.78
18"			27.78	45.78

\*CUSTOM LENGTHS AVAILABLE





## BUMP STOP BUMP STOP SERIES

2.0 DIAMETER		2.5 DIAMETER	
2"	BS2020	2.5"	BS2525
4"	BS2040	4"	BS2540



King Bump Stops are available in 4 different sizes.



## MOUNTING SLEEVE BUMP STOP SERIES

2.0 DIAMETER		2.5 DIAMETER	
2"	BS2021	2.5"	BS2526
4"	BS2041	4"	BS2541



## BUMP STOP SERIES

King bump stops provide an additional level of bottoming control when you are using every bit of suspension travel available. We offer 2.0 and 2.5 inch diameter bodies with stroke lengths from 2 to 4 inches to fit any mounting location requirements and handle any suspension arresting loads. Our 4130 Chromoly mounting sleeves are precision machined to size and offer a secure and sturdy mount without pinching the bump stop body. Our unique Schrader cover mounts to the housing not the Schrader valve itself to protect it and acts as a double seal to keep dust and moisture out. Our bump stops contain a unique piston design that offers superior flow characteristics and the same quality micro polished shafts and advanced seal technology as our race shocks. Our long wearing nylon contact pad insures quiet operation and mounts with a simple yet effective single bolt design.

King bump stops help you use all the suspension travel you have to get the most out of your vehicle. They are easily tuned and serviceable with simple hand tools. You really need to experience the comfort and control a set of King bump stops provide. Nothing rides like King.

100% made in the USA under the strictest tolerances from the highest quality materials obtainable. Easily tunable and serviceable with simple hand tools.

Double o-ring Schrader cover that mounts to the body, not the valve itself creates a positive seal and keeps dirt and moisture out.

Unique mounting boss design with locating pin securely locates the bump stop without pinching the outside of the tube.

Bump stop bodies are precision bored to within +/- .001, then honed after cadmium plating to remove buildup for a tight piston seal and optimum valving function.

Aluminum components are machined from aircraft quality billet.

Large 1-1/4" or 1-5/8" diameter shafts have a minimum tensile strength of 75,000 pounds per square inch. They are hard chromed and micro-polished to a 6 RA finish for extended seal life.

long wearing nylon contact pad insures quiet operation and mounts with a simple yet effective single bolt design.

4130 Chromoly bump stop mounting sleeve is bored to size after tig welding to provide a precise fit and strong mounting surface.





FROM TROPHY TRUCK TO  
**YOUR TRUCK**



TOYOTA TUNDRA 07+ FRONT COIL OVER

## OEM PERFORMANCE KITS

King's new line of Original equipment manufacturer, (OEM), shock upgrade kits provide a bolt on suspension system that elevates your on and off-road performance to unmatched levels. Each kit has been subjected to punishing real world testing to develop the optimal damping curves and spring rates for your vehicle. Built with the same quality of materials and precise tolerances found on our high end race shocks our OEM upgrade kits enable you to experience the famous King ride quality on your daily driver.

Built with race winning design features our kits come complete and provide simple 100% bolt on installation with no cutting or welding done to your vehicle. Our front kits provide an adjustable ride height and up to a 25% increase in wheel travel. Rear kits typically allow a 15% travel increase. Large 2.5" diameter shock bodies and external reservoirs dramatically increase fluid capacity and heat dissipation to provide sustained damping performance even under the most punishing conditions. Our OEM upgrade shocks feature the same serviceable design that allows for valve adjustments with simple hand tools just like our race shocks.

Our experienced shock technicians are a phone call away to help should any questions arise during installation or use. Our kits are available ready to bolt into stock vehicles or with custom length rod end for vehicles running lifted aftermarket suspensions.

100% made in the USA under the strictest tolerances from the highest quality materials obtainable. Easily tunable and serviceable with simple hand tools.

Lightweight hard anodized 6063 aluminum alloy reservoirs dissipate heat quickly and will not rust due to gas charging contamination. High quality fittings are mated to Aeroquip high pressure hoses which resist abrasion and kinking.

2.5" Shock cylinders are precision bored to within +/- .001, then honed after cadmium plating to remove buildup for a tight piston seal and optimum valving function. Coilover shocks are machined with our own truncated thread design for ultimate strength and trouble free spring preload and height adjustments.

The heat treated 6061 aluminum alloy piston has our highly developed port configurations that contribute to the unique damping performance and famous King ride quality.

Wear bands are made from an exclusive Rulon composite that wears longer than any other material available.

Large 3/4" or 7/8" diameter shafts have a minimum tensile strength of 100,000 pounds per square inch. They are hard chromed and micro-polished to a 6 RA finish for extended seal life.

Aluminum components and vehicle specific mounts are machined from aircraft quality billet.

Steel Teflon lined spherical bearings for smooth articulation and long life with no metal to metal contact.

Front and rear kits all include the necessary vehicle specific mounting brackets and hardware along with detailed installation instructions.



## All Available Performance Series Kits

NEW KITS CONTINUOUSLY DEVELOPED CHECK WEBSITE OR CALL FOR UPDATES

\*International valving, increased damping for heavy duty use.

Part #	International Valving Part #	Product Description	Reservoir Type	Max Tire	Lift
25001-259	25001-259E	Land Cruiser HDJ100, Toyota 98-02 Front Shocks	Piggyback	N/A	0"
25001-258	25001-258E	Land Cruiser HDJ100, Toyota 98-02 Rear Shocks	Piggyback	N/A	0"
25001-261	25001-261E	Land Cruiser HDJ120, Toyota 03-07 Front Coil Overs	Hose Remote	N/A	2"-3.5"
25001-262	25001-262E	Land Cruiser HDJ120, Toyota 03-07 Rear Shocks	Hose Remote	N/A	0"
25001-266	25001-266E	Land Cruiser HDJ200, Toyota 08+ Front ?	Hose Remote	N/A	2"-3.5"
25001-267	25001-267E	Land Cruiser HDJ200, Toyota 08+ Rear ?	Hose Remote	N/A	0"
25001-151	N/A	Tacoma, Toyota 96-04 (6 Lug) Front Coil Overs	Internal	32"	2"-3.5"
25001-119	N/A	Tacoma, Toyota 05+ (6 Lug) Front Coil Overs	Hose Remote	32"	2"-3.5"
25001-121	N/A	Tacoma, Toyota 05+ (6 Lug) Rear Shocks	Hose Remote	32"	0"
25001-138	N/A	Tundra, Toyota 99-06 Front Coil Overs	Internal	33"	2"-3.5"
25001-143	N/A	Tundra, Toyota 07+ Front Coil Overs	Hose Remote	33"	3"-4"
25001-144	N/A	Tundra, Toyota 07+ Rear Shocks	Hose Remote	33"	0"
25001-124	25001-124E	FJ Cruiser, Toyota 06-08 Front Coil Overs	Hose Remote	33"	2"-3.5"
25001-125	25001-125E	FJ Cruiser, Toyota 06-08 Rear Shocks	Hose Remote	33"	0"
25001-263	25001-263E	Hilux, Toyota 05-09 Front Coil Overs	Hose Remote	N/A	2"-3.5"
25001-260	25001-260E	Hilux, Toyota 05-09 Rear Shocks	Piggyback	N/A	0"
25001-168	N/A	F150, Ford 04-08 2wd Front Coil Overs	Internal	33"	2"-3.5"
25001-170	N/A	F150, Ford 04-08 2wd Rear Shocks	Piggyback	33"	0"
25001-167	N/A	F150, Ford 04-08 4wd Front Coil Overs	Hose Remote	33"	2"-3.5"
25001-169	N/A	F150, Ford 04-08 4wd Rear Shocks	Piggyback	33"	0"
25001-211	N/A	F150, Ford 09+ 2wd Front Coil Overs	Internal	33"	2"-3.5"
25001-212	N/A	F150, Ford 09+ 2wd Rear Shocks	Piggyback	33"	0"
25001-213	N/A	F150, Ford 09+ 4wd Front Coil Overs	Hose Remote	33"	2"-3.5"
25001-214	N/A	F150, Ford 09+ 4wd Rear Shocks	Piggyback	33"	0"
25001-146	N/A	F250 /350, Ford 05+ Front Coil Over	Hose Remote	37"	2"-3.5"
25001-171	N/A	F250 /350, Ford 05+ Rear Shocks	Piggyback	37"	0"
25001-039	N/A	Titan, Nissan 04+ Front Coil Overs	Hose Remote	33"	2"-3.5"
25001-142	N/A	Titan, Nissan 04+ Rear Shocks	Piggyback	33"	0"
25001-111	25001-111E	Frontier, Nissan 05-08 Front Coil Overs	Hose Remote	32"	2"-3.5"
25001-110	25001-110E	Frontier, Nissan 05-08 Rear Shocks	Piggyback	32"	0"
25001-156	25001-156E	Patrol, Nissan 05-09 Front Shocks	Hose Remote	N/A	0"
25001-257	25001-157E	Patrol, Nissan 05-09 Rear Shocks	Piggyback	N/A	0"
25001-264	25001-264E	Pajero / Montero / DID, Mitsubishi 06+ Front Coil Overs	Hose Remote	N/A	2"-3.5"
25001-265	25001-265E	Pajero / Montero / DID, Mitsubishi 06+ Rear Shocks	Hose Remote	N/A	0"
25001-160	25001-160E	Wrangler TJ, Jeep 97-06 Front Shocks	Piggyback	N/A	0"
25001-161	25001-161E	Wrangler TJ, Jeep 97-06 Rear Shocks	Piggyback	N/A	0"
25001-180	25001-180E	Wrangler JK, Jeep 07+ Front Shocks	Piggyback	N/A	0"
25001-181	25001-181E	Wrangler JK, Jeep 07+ Rear Shocks	Piggyback	N/A	0"
25001-166	25001-166E	Wrangler JK, Jeep 07+ 2.0 FP Front Shocks	Piggyback	N/A	0"
25001-167	25001-167E	Wrangler JK, Jeep 07+ 2.0 FP Rear Shocks	Piggyback	N/A	0"
25001-163	25001-163E	Grand Cherokee WK, Jeep 05+ Front Coil Overs	Hose Remote	N/A	2"-3.5"
25001-166	25001-166E	Grand Cherokee WK, Jeep 05+ Rear Shocks	Piggyback	N/A	0"
25001-148	N/A	1500/Tahoe, Chevy 07+ Front Coil Overs	Hose Remote	33"	2"-3.5"
25001-154	N/A	1500, Chevy 07+ Rear Shocks	Piggyback	33"	0"
25001-150	N/A	Tahoe, Chevy 07 Rear Shocks	Piggyback	33"	0"
25001-184	N/A	2500/3500HD, Chevy 01+ Front Shocks	Hose Remote	33"	0"
25001-201	N/A	2500/3500HD, Chevy 01+ Rear Shocks	Piggyback	33"	0"
25001-270	25001-270E	H2, Hummer 03+ Front Shocks	Hose Remote	35"	0"
25001-271	25001-271E	H2, Hummer 03+ Rear Shocks	Piggyback	35"	0"

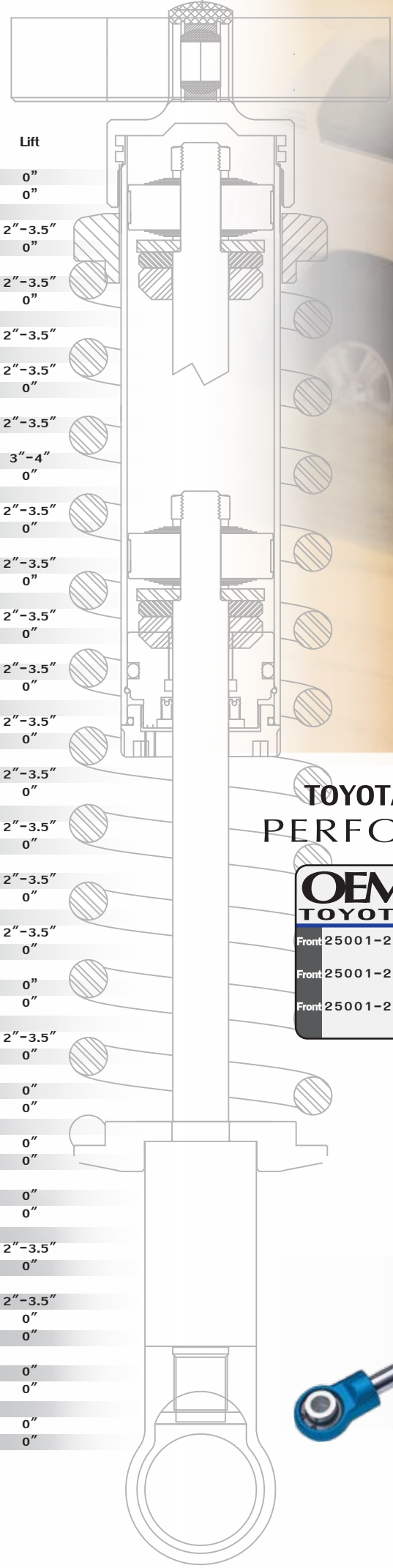

### TOYOTA LAND CRUISER FRONT PERFORMANCE SERIES

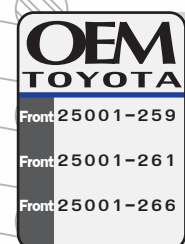

- Front 25001-259 Land Cruiser HDJ100 98-02 Front Shocks
- Front 25001-261 Land Cruiser HDJ120 03-07 Front Coil Overs
- Front 25001-266 Land Cruiser HDJ200 08+ Front Coil Overs

\*\*Custom Lengths Available For Aftermarket Lift Kits

KITS COME COMPLETE WITH BRACKETS AND HARDWARE



### TOYOTA LAND CRUISER REAR PERFORMANCE SERIES

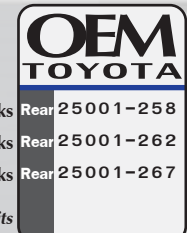

- Rear 25001-258 Land Cruiser HDJ100 98-02 Rear Shocks
- Rear 25001-262 Land Cruiser HDJ120 03-07 Rear Shocks
- Rear 25001-267 Land Cruiser HDJ200 08+ Rear Shocks

\*\*Custom Lengths Available For Aftermarket Lift Kits

KITS COME COMPLETE WITH BRACKETS AND HARDWARE





## TOYOTA TRUCKS FRONT PERFORMANCE SERIES



- Front 25001-151 Tacoma 96-04 (6 Lug) Front Coil Overs
- Front 25001-119 Tacoma 05+ (6 Lug) Front Coil Overs
- Front 25001-138 Tundra 99-06 Front Coil Overs
- Front 25001-143 Tundra 07+ Front Coil Overs

\*\*Custom Lengths Available For Aftermarket Lift Kits

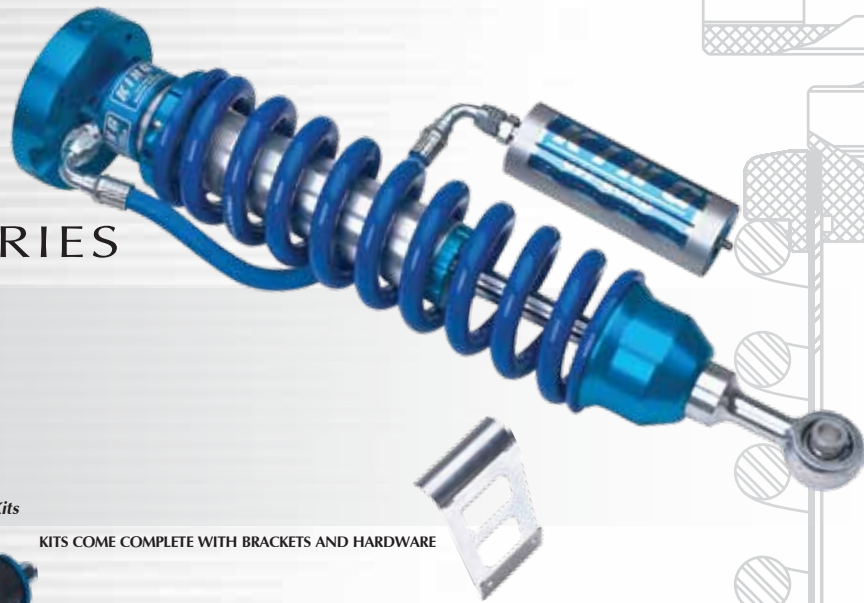

KITS COME COMPLETE WITH BRACKETS AND HARDWARE

## TOYOTA TRUCKS REAR PERFORMANCE SERIES



- Rear 25001-121 Tacoma 05+ (6 Lug) Rear Shocks
- Rear 25001-144 Tundra 08+ Rear Shocks

\*\*Custom Lengths Available For Aftermarket Lift Kits



KITS COME COMPLETE WITH BRACKETS AND HARDWARE

## TOYOTA FJ CRUISER FRONT PERFORMANCE SERIES



- Front 25001-124 FJ Cruiser 06+ Front Coil Overs

\*\*Custom Lengths Available For Aftermarket Lift Kits

KITS COME COMPLETE WITH BRACKETS AND HARDWARE



## TOYOTA FJ CRUISER REAR PERFORMANCE SERIES



- Rear 25001-125 FJ Cruiser 06+ Rear Shocks

\*\*Custom Lengths Available For Aftermarket Lift Kits

KITS COME COMPLETE WITH BRACKETS AND HARDWARE





VEHICLE SHOWN WITH AFTERMARKET LIFT KIT AND CUSTOM SHOCK CONFIGURATION



### FORD F-150 FRONT PERFORMANCE SERIES



Front: 25001-168	F150 04-08 2wd Front Coil Overs
Front: 25001-167	F150 04-08 4wd Front Coil Overs
Front: 25001-211	F150 09+ 2wd Front Coil Overs
Front: 25001-213	F150 09+ 4wd Front Coil Overs

**\*\*Custom Lengths Available For Aftermarket Lift Kits**

KITS COME COMPLETE WITH BRACKETS AND HARDWARE



### FORD F-150 REAR PERFORMANCE SERIES



F150 04-08 2wd Rear Shocks	Rear: 25001-170
F150 04-08 4wd Rear Shocks	Rear: 25001-169
F150 09+ 2wd Rear Shocks	Rear: 25001-212
F150 09+ 4wd Rear Shocks	Rear: 25001-214

**\*\*Custom Lengths Available For Aftermarket Lift Kits**

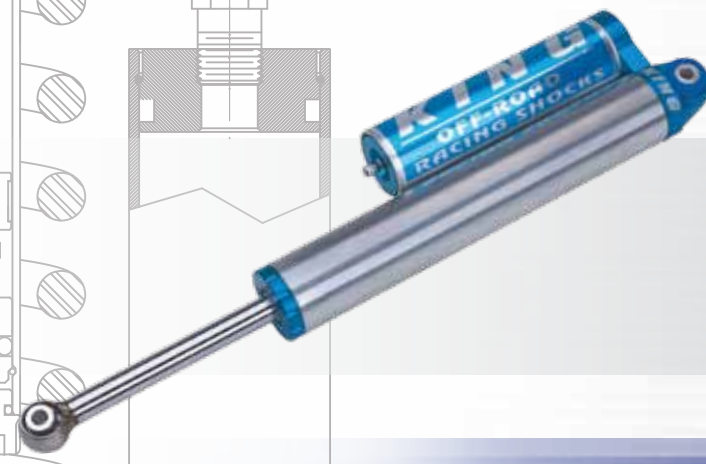

### FORD SUPER DUTY FRONT PERFORMANCE SERIES



Front: 25001-146	F250/350 05+ 4wd Front Coil Overs
------------------	-----------------------------------

**\*\*Custom Lengths Available For Aftermarket Lift Kits**

KITS COME COMPLETE WITH BRACKETS AND HARDWARE



### FORD SUPER DUTY REAR PERFORMANCE SERIES



F250/350 05+ 4wd Rear Shocks	Rear: 25001-171
------------------------------	-----------------

**\*\*Custom Lengths Available For Aftermarket Lift Kits**

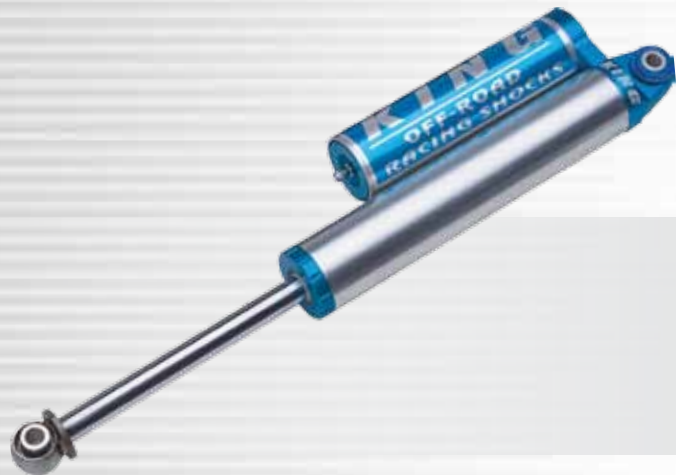



## JEEP WRANGLER 2.5" SHOCKS PERFORMANCE SERIES

Wrangler TJ 97-06 2.5" Front Shocks  
Wrangler JK 07+ 2.5" Front Shocks

<b>OEM JEEP</b>	
Front	25001-160
Front	25001-180
Rear	25001-161
Rear	25001-167

Wrangler TJ 97-06 2.5" Rear Shocks  
Wrangler JK 07+ 2.5" Rear Shock

**\*\*Available For All Aftermarket Lift Kits**



KITS COME COMPLETE WITH BRACKETS AND HARDWARE

## JEEP WRANGLER 2.0" SHOCKS PERFORMANCE SERIES

Wrangler JK 07+ 2.0" Floating Piston Rear Shocks

<b>OEM JEEP</b>	
Front	25001-166
Rear	25001-167

Wrangler JK 07+ 2.0" Floating Piston Front Shocks

**\*\*Available For All Aftermarket Lift Kits**



KITS COME COMPLETE WITH BRACKETS AND HARDWARE

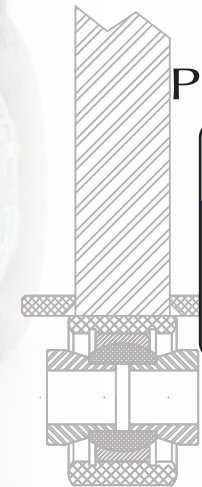
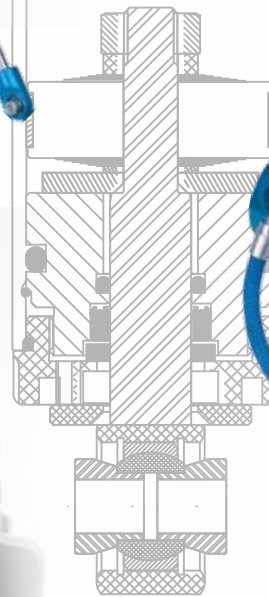
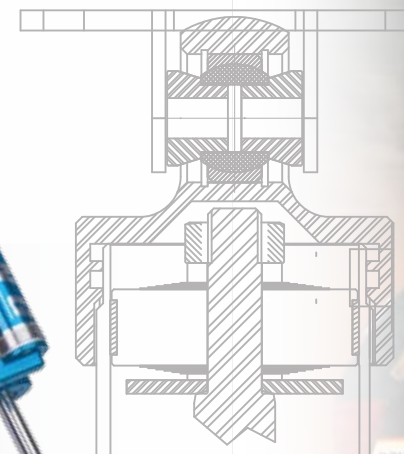

## JEEP GRAND CHEROKEE FRONT PERFORMANCE SERIES

KITS COME COMPLETE WITH BRACKETS AND HARDWARE

Grand Cherokee WK 05 + Front Coil Overs

<b>OEM JEEP</b>	
Front	25001-163

**\*\*Custom Lengths Available For Aftermarket Lift Kits**

SHOCK BOLTS TO EXISTING FACTORY MOUNT AS SHOWN

## JEEP GRAND CHEROKEE REAR PERFORMANCE SERIES

<b>OEM JEEP</b>	
Rear	25001-167

Grand Cherokee WK 05 + Rear Shocks

**\*\*Custom Lengths Available For Aftermarket Lift Kits**



VEHICLE SHOWN WITH AFTERMARKET LIFT KIT





### NISSAN TRUCKS FRONT PERFORMANCE SERIES

<b>OEM NISSAN</b>	
Titan 04 + Front Coil Overs	Front 25001-039
Frontier 05 + Front Coil Overs	Front 25001-111

**\*\*Custom Lengths Available For Aftermarket Lift Kits**

KITS COME COMPLETE WITH BRACKETS AND HARDWARE

### NISSAN TRUCKS REAR PERFORMANCE SERIES

<b>OEM NISSAN</b>	
Rear 25001-142	Titan 04 + Rear Shocks
Rear 25001-110	Frontier 05+ Rear Shocks

**\*\*Custom Lengths Available For Aftermarket Lift Kits**

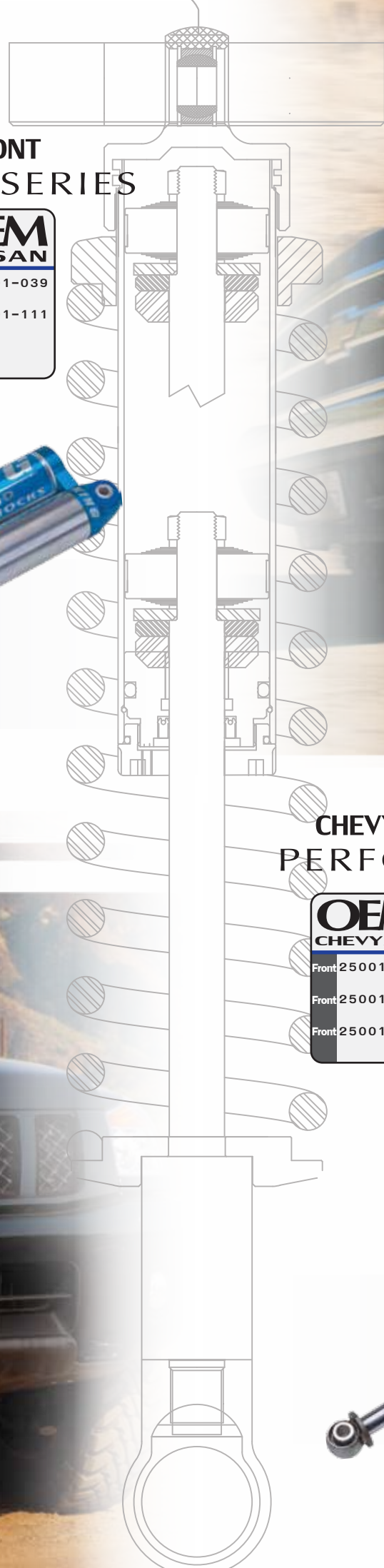

### CHEVY / GMC / HUMMER FRONT PERFORMANCE SERIES

<b>OEM CHEVY/GM</b>	
Front 25001-148	Silverado / Sierra / Tahoe / Yukon 07+ Front Coil Overs
Front 25001-184	Chevy 2500/3500HD 01+ Front Shocks
Front 25001-270	Hummer H2 03+ Front Shocks

**\*\*Custom Lengths Available For Aftermarket Lift Kits**

KITS COME COMPLETE WITH BRACKETS AND HARDWARE



### CHEVY / GMC / HUMMER REAR PERFORMANCE SERIES



<b>OEM CHEVY/GM</b>	
Silverado / Sierra / 07+ Rear Shocks	Rear 25001-154
Tahoe / Yukon 07+ Rear Shocks	Rear 25001-150
Chevy 2500/3500HD 01+ Front Shocks	Rear 25001-201
Hummer H2 03+ Rear Shocks	Rear 25001-271

**\*\*Custom Lengths Available For Aftermarket Lift Kits**







## UTV SERIES

After a year of extensive research to develop a UTV shock capable of winning the Baja 1000 and 500, (which we were the first to do), King's full line of performance shock systems for side by sides are now available to the public. Whether you're working on the farm, hitting the dunes or in the heat of competition, few vehicles offer the versatility and enjoyment that the modern UTV provides.

Designing a shock to work under such diverse conditions is no easy task. King's shock engineers utilized their extensive knowledge designing shocks that perform on all types of vehicles in some of the world's toughest environments to produce a shock line that fits the needs of UTV enthusiasts and racers. Our UTV shocks come in lengths to fit your stock suspension or custom versions to work with long travel kits. Our UTV shocks are built with the same quality materials and strict precision tolerances that we use in our high end race shocks. King UTV shocks with our optional Wide Range Compression Adjuster give you the ability to precisely adjust compression from super soft to super firm with a simple twist. The clearly marked billet knob offers 20 positive clicks of finely tuned adjustment.

Our shocks are easily serviceable with simple hand tools and offer machined billet construction, tunable valving, nitrogen pressure adjustable external reservoirs, and ride height adjustment. Now you can experience the ultimate performance and famous King ride quality on your UTV. Regardless if you are just out cruising or battling for the lead in competition the same set of King Shock's will give you the damping control you need. Nothing rides like a King.

100% made in the USA under the strictest tolerances from the highest quality materials obtainable. Easily tunable and serviceable with simple hand tools.

Bolt on installation available in stock lengths or extended versions for long travel suspensions.

Integrated piggyback style mounted light weight hard anodized 6061 aluminum alloy reservoirs dissipate heat quickly and will not rust due to gas charging contamination.

Shock cylinders are precision bored to within +/- .001 to ensure seal fit. Cylinders are honed after cadmium plating for precise piston sealing. Machined with our own truncated thread design for ultimate strength and trouble free spring preload and ride height adjustments.

Optional Wide Range Compression Adjuster. Clearly marked billet adjuster knob offers 20 positive clicks of finely tuned adjustment.

Large 3/4" diameter shafts have a minimum tensile strength of 100,000 pounds per square inch. They are hard chromed and micro-polished to a 6 RA finish for extended seal life.

Urethane foam bump stop included to cushion full bottoming.

Aluminum components are machined from aircraft quality billet.

Steel Teflon lined spherical bearings for smooth articulation and long life with no metal to metal contact.





Wide Range Compression Adjuster. Clearly marked billet adjuster knob offers 20 positive clicks of finely tuned adjustment.



## KAWASAKI TERYX PERFORMANCE SERIES

**UTV**  
KAWASAKI

Front	20001-112	08 + TERYX Stock Replacement Front Coil Overs
Front	20001-174	08 + TERYX Stock Replacement Front Coil Overs Adjustable
Rear	20001-113	08 + TERYX Stock Replacement Rear Coil Overs
Rear	20001-173	08 + TERYX Stock Replacement Rear 4 Seat Coil Overs
Rear	20001-175	08 + TERYX Stock Replacement Rear Coil Overs Adjustable
Rear	20001-176	08 + TERYX Stock Replacement Rear 4 Seat Coil Overs Adjustable

**\*\*Custom Lengths Available For Aftermarket Kits**



Wide Range Compression Adjuster. Clearly marked billet adjuster knob offers 20 positive clicks of finely tuned adjustment.



Extended Sway Bar Pivot Arm  
Included in front shock kits

## POLARIS RZR PERFORMANCE SERIES

**UTV**  
POLARIS

Front	20001-110	08 + RZR Stock Replacement Front Coil Overs
Front	20001-187	08 + RZR Stock Replacement Front Coil Overs Adjustable
Front	20001-118	09 + RZR-S Stock Replacement Front Coil Overs
Front	20001-189	09 + RZR-S Stock Replacement Front Coil Overs Adjustable
Rear	20001-111	08 + RZR Stock Replacement Rear Coil Overs
Rear	20001-188	08 + RZR Stock Replacement Rear Coil Overs Adjustable
Rear	20001-119	09 + RZR-S Stock Replacement Rear Coil Overs
Rear	20001-190	09 + RZR-S Stock Replacement Rear Coil Overs Adjustable

**\*\*Custom Lengths Available For Aftermarket Kits**





## ARCTIC CAT PERFORMANCE SERIES

### UTV ARCTIC CAT

Front	20001-115	06 + Prowler Stock Replacement Front Coil Overs
Front	20001-137	06 + Prowler Stock Replacement Front Coil Overs Adjustable
Front	20001-135	09 + XTC 1000 Stock Replacement Front Coil Overs
Front	20001-132	09 + XTC 1000 Stock Replacement Front Coil Overs Adjustable
Rear	20001-130	06 + Prowler Stock Replacement Rear Coil Overs
Rear	20001-203	06 + Prowler Stock Replacement Rear Coil Overs Adjustable
Rear	20001-131	06 + Prowler Stock Replacement 4 Seat Rear Coil Overs
Rear	20001-204	06 + Prowler Stock Replacement 4 Seat Rear Coil Overs Adjustable
Rear	20001-136	09 + XTC 1000 Stock Replacement Rear Coil Overs
Rear	20001-133	09 + XTC 1000 Stock Replacement Rear Coil Overs Adjustable
Rear	20001-186	09 + XTC 1000 Stock Replacement 4 Seat Rear Coil Overs
Rear	20001-134	09 + XTC 1000 Stock Replacement 4 Seat Rear Coil Overs Adjustable

*\*\*Custom Lengths Available For Aftermarket Kits*

Wide Range Compression Adjuster. Clearly marked billet adjuster knob offers 20 positive clicks of finely tuned adjustment.



Wide Range Compression Adjuster. Clearly marked billet adjuster knob offers 20 positive clicks of finely tuned adjustment.



## YAMAHA RHINO PERFORMANCE SERIES

### UTV YAMAHA

	04 + Rhino Stock Replacement Front Coil Overs	Front	20001-192
	04 + Rhino Stock Replacement Front Coil Overs Adjustable	Front	20001-202
	04 + Rhino Stock Replacement Rear Coil Overs	Rear	20001-193
	04 + Rhino Stock Replacement Rear Coil Overs Adjustable	Rear	20001-195
	04 + Rhino Stock Replacement 4 Seat Rear Coil Overs	Rear	20001-194
	04 + Rhino Stock Replacement 4 Seat Rear Coil Overs Adjustable	Rear	20001-196

*\*\*Custom Lengths Available For Aftermarket Kits*







## KING JACK

The King Race Jack was conceived as a tough lightweight jacking device to be carried onboard race vehicles as a replacement for heavy awkward floor jacks. The King jack is a mechanical design that does not rely on hydraulic pressure to lift your vehicle. It will never lose fluid and leave you stranded in the middle of nowhere. The actuating nut is the same 3/4" hex that your lug nuts use so wheel changes are quick with no additional tools needed. The jacking boss is adjustable up and down on the jack body to compensate for the height of your vehicle. The jacking range is a full 14" to provide enough clearance for even the tallest tires. A King race jack will provide peace of mind and ease of operation when you need it most, don't get caught without one. Recommended for open wheel vehicles under 4500 pounds. **Part # SJ1001**

100% made in the USA under the strictest tolerances from the highest quality materials obtainable. Easily serviceable with simple hand tools.

- Actuation screw has the same 3/4" hex as your lug nuts for quick tire changes.
- Cadmium plated steel body is sealed from the elements.
- Knurled Jacking pin adjusts up or down to match the ride height of your vehicle.
- Billet aircraft quality aluminum components.
- Large 1-1/4" hard chromed shaft has a full 14" of travel.
- Steel Teflon lined spherical bearings for smooth articulation and long life with no metal to metal contact.
- Rod end attaches to large round base through stainless steel Teflon lined spherical bearings for smooth articulation when jacking on uneven terrain.

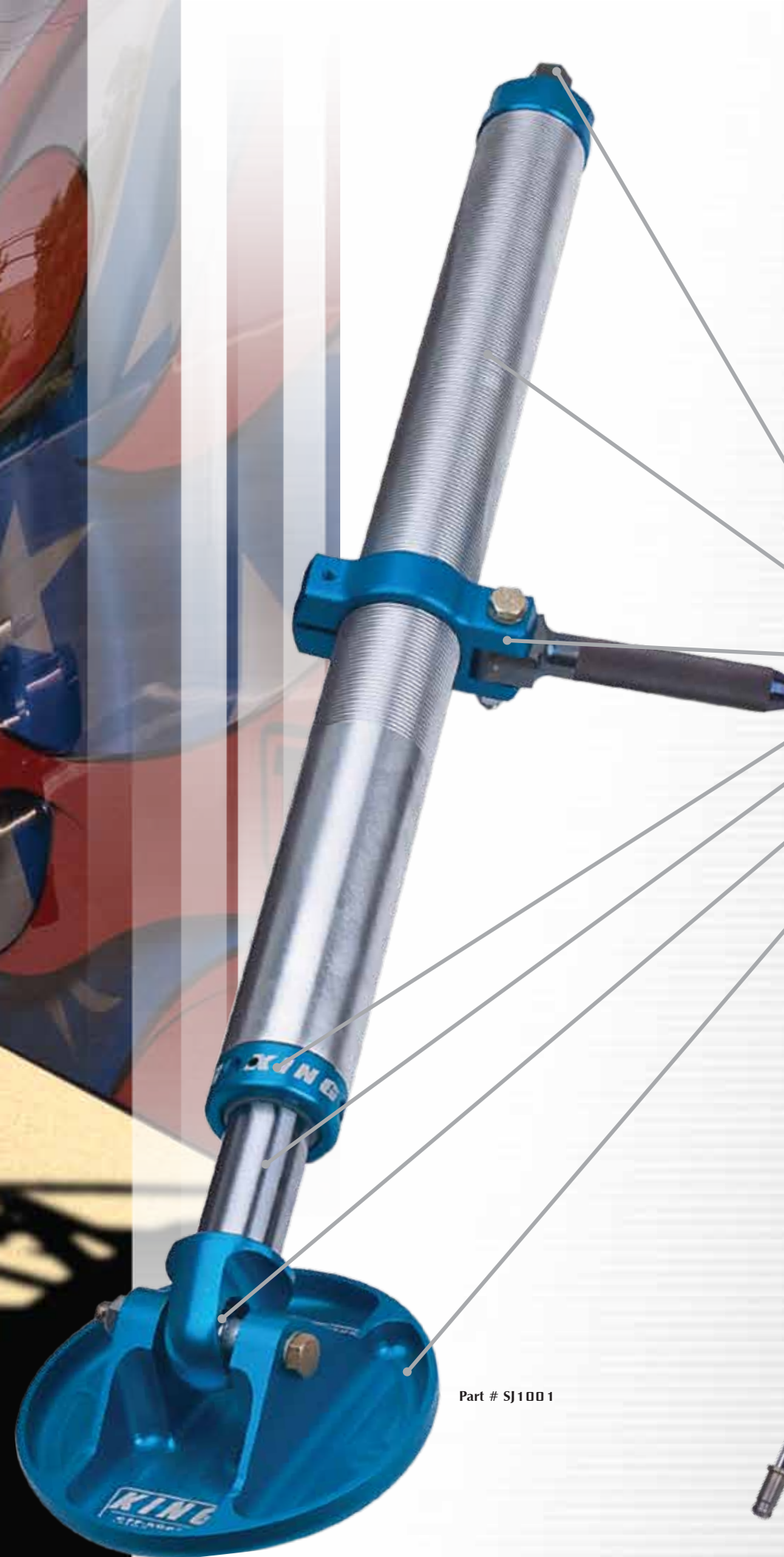

Part # SJ1001

## KING AIR JACK

King air jacks are a simple compact solution to lift your vehicle when service is needed. The 3.0" diameter bodies are designed to be permanently mounted on your fabricated mounts to each side of the chassis so they can independently lift one entire side of your race vehicle off the ground. The jacks are extended up to 18" by either Nitrogen or CO2 gas from an onboard tank. The double acting cylinders, (pressurized extension and retraction) have a pivoting base and a unique, heat treated shaft that allows it to deflect so you can jack on un-even terrain. King air jacks will get you back racing quickly giving you the competitive edge you need. **Part # AJ1001**

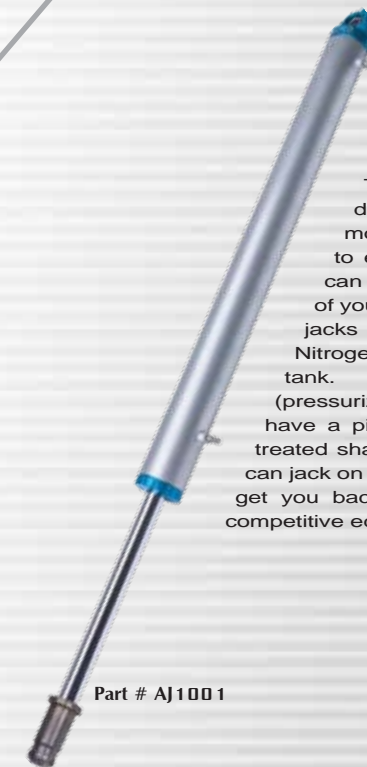

Part # AJ1001



### 2.5 INCH INSIDE DIAMETER FITS 2.0 DIAMETER SHOCKS

<b>2.5</b> 3" LENGTH Lbs 100 SPR 25-03-50	<b>2.5</b> 4.5" LENGTH Lbs 100 SPR 25-045-100	<b>2.5</b> 8" LENGTH Lbs 100 SPR 25-08-100 150 SPR 25-08-150 200 SPR 25-08-200 250 SPR 25-08-250 300 SPR 25-08-300 350 SPR 25-08-350 400 SPR 25-08-400 425 SPR 25-08-425 450 SPR 25-08-450 500 SPR 25-08-500 600 SPR 25-08-600 800 SPR 25-08-800	<b>2.5</b> 10" LENGTH Lbs 100 SPR 25-10-100 150 SPR 25-10-150 200 SPR 25-10-200 250 SPR 25-10-250 300 SPR 25-10-300 350 SPR 25-10-350 400 SPR 25-10-400 450 SPR 25-10-450 500 SPR 25-10-500 600 SPR 25-10-600 700 *SPR 25-10-700 800 *SPR 25-10-800	<b>2.5</b> 12" LENGTH Lbs 125 SPR 25-12-100 150 SPR 25-12-125 200 SPR 25-12-150 250 SPR 25-12-200 250 SPR 25-12-250 300 SPR 25-12-300 350 SPR 25-12-350 400 SPR 25-12-400 450 SPR 25-12-450 500 SPR 25-12-500 600 SPR 25-12-600 700 *SPR 25-12-700 800 *SPR 25-12-800 900 *SPR 25-12-900 1000 *SPR 25-10-1000	<b>2.5</b> 14" LENGTH Lbs 80 SPR 25-14-80 100 SPR 25-14-100 150 SPR 25-14-150 200 SPR 25-14-200 250 SPR 25-14-250 300 SPR 25-14-300 350 SPR 25-14-350 400 SPR 25-14-400 450 SPR 25-14-450 500 SPR 25-14-500 600 SPR 25-14-600 650 *SPR 25-14-650	<b>2.5</b> 16" LENGTH Lbs 200 SPR 25-16-200 250 SPR 25-16-250 300 SPR 25-16-300 350 SPR 25-16-350 400 SPR 25-16-400 450 SPR 25-16-450 500 SPR 25-16-500 600 SPR 25-16-600 650 *SPR 25-16-650 700 *SPR 25-16-700 750 *SPR 25-16-750	<b>2.5</b> 18" LENGTH Lbs 600 SPR 25-18-600
--	--	--	---	--	--	---	--

### 3.0 INCH INSIDE DIAMETER FITS 2.5 DIAMETER SHOCKS

<b>3.0</b> 4" LENGTH Lbs 500 SPR 3-04-500	<b>3.0</b> 6" LENGTH Lbs 500 SPR 3-06-500	<b>3.0</b> 10" LENGTH Lbs 100 *SPR 3-10-100 150 SPR 3-10-150 200 SPR 3-10-200 250 SPR 3-10-250 300 SPR 3-10-300 350 SPR 3-10-350 400 SPR 3-10-400 500 SPR 3-10-500 550 SPR 3-10-550	<b>3.0</b> 12" LENGTH Lbs 125 SPR 3-12-125 200 SPR 3-12-200 250 SPR 3-12-250 300 SPR 3-12-300 350 SPR 3-12-350 400 SPR 3-12-400 450 SPR 3-12-450 500 SPR 3-12-500 600 SPR 3-12-600	<b>3.0</b> 14" LENGTH Lbs 150 SPR 3-14-150 200 SPR 3-14-200 250 SPR 3-14-250 300 SPR 3-14-300 350 SPR 3-14-350 400 SPR 3-14-400 450 SPR 3-14-450 500 SPR 3-14-500 550 SPR 3-14-550 600 SPR 3-14-600 650 SPR 3-14-650 700 SPR 3-14-700	<b>3.0</b> 16" LENGTH Lbs 200 SPR 3-16-200 250 SPR 3-16-250 300 SPR 3-16-300 350 SPR 3-16-350 400 SPR 3-16-400 450 SPR 3-16-450 500 SPR 3-16-500 600 SPR 3-16-600 800 *SPR 3-16-800	<b>3.0</b> 18" LENGTH Lbs 150 SPR 3-18-150 200 SPR 3-18-200 250 SPR 3-18-250 300 SPR 3-18-300 400 SPR 3-18-400 500 SPR 3-18-500 600 SPR 3-18-600 700 SPR 3-18-700 750 *SPR 3-18-750	<b>3.0</b> 19" LENGTH Lbs 800 SPR-195-800
--	--	--	---	---	--	--	--

### 3.75 INCH INSIDE DIAMETER FITS 3.0 DIAMETER SHOCKS

<b>3.75</b> 4" LENGTH Lbs 250 SPR 375-04-250 350 SPR 375-04-350 400 SPR 375-04-400 500 SPR 375-04-500	<b>3.75</b> 8" LENGTH Lbs 100 SPR 375-08-100 150 SPR 375-08-150 200 SPR 375-08-200 250 SPR 375-08-250 300 SPR 375-08-300 350 SPR 375-08-350 400 SPR 375-08-400 450 SPR 375-08-450 500 SPR 375-08-500	<b>3.75</b> 10" LENGTH Lbs 100 SPR 375-10-100 150 SPR 375-10-150 200 SPR 375-10-200 250 SPR 375-10-250 300 SPR 375-10-300 350 SPR 375-10-350 400 SPR 375-10-400 450 SPR 375-10-450 500 SPR 375-10-500	<b>3.75</b> 13" LENGTH Lbs 100 SPR 375-13-100 150 SPR 375-13-150 200 SPR 375-13-200 250 SPR 375-13-250 300 SPR 375-13-300 350 SPR 375-13-350 400 SPR 375-13-400 500 SPR 375-13-500 600 SPR 375-13-600 700 SPR 375-13-700	<b>3.75</b> 16" LENGTH Lbs 600 SPR 375-16-600	<b>3.75</b> 17" LENGTH Lbs 400 SPR 375-17-400	<b>3.75</b> 20" LENGTH Lbs 300 SPR 375-20-300 350 SPR 375-20-350 400 *SPR 375-20-400 500 *SPR 375-20-500 600 *SPR 375-20-600 650 *SPR 375-20-650 700 *SPR 375-20-700 750 *SPR 375-20-750	<b>3.75</b> 22" LENGTH Lbs 300 *SPR 375-22-300 350 SPR 375-22-350 400 SPR 375-22-400 450 SPR 375-22-450 500 SPR 375-22-500 550 SPR 375-22-550 600 SPR 375-22-600 700 SPR 375-22-700 800 *SPR 375-22-800	<b>3.75</b> 24" LENGTH Lbs 300 SPR 375-24-300 350 SPR 375-24-350 400 SPR 375-24-400 450 SPR 375-24-450 500 SPR 375-24-500 550 SPR 375-24-550 600 SPR 375-24-600 700 *SPR 375-24-700
---	---	--	--	--	--	--	--	---

\* Spring may not come in King Blue



## KING SPRINGS

King has over 10,000 springs in stock. The largest and most complete spring inventory in the off-road industry.

King coil springs are manufactured to our specifications in the USA using the finest quality, high tensile, chrome silicon wire available. Our springs are specifically wound for off-road applications, not repackaged car springs. Our spring rates, wire diameters and coil lengths have been developed through extensive real world testing on all types of terrain. Our race winning designs have been put to the test in the heat of battle from Baja to Dakar.

All springs have closed and ground ends to sit flat and deflect true. We have the largest selection of springs to match your application, over 10,000 in stock, ready to go. We sell thousands of springs a month with barely a return ever, yet we offer a lifetime warranty to the original purchaser against sagging and breakage. You will have the added peace of mind knowing you're covered, just in case. In the rare occurrence that a spring does fail, it will be cheerfully replaced with no questions asked. Our customer support is second to none just like the quality and performance of our products. Nothing rides like a King.

#### Decoding King coil part numbers:

Example; SPR375-22-250  
375 = 3.75" internal diameter spring  
          \* fits 3.0" shock.  
22 = 22 inches long.  
250 = 250 lbs. spring rate.

The spring rate is a number that represents the amount of force in pounds that it takes to compress the coil 1 inch.

King shocks are available with many coil spring options depending on your application. A single rate spring is a single coil on the shock. As the coil compresses the rate increases at a linear rate. If the spring rate for that coil is 300lbs per inch then compressing that coil one inch generates 300lbs., two inches generates 600lbs., 3 inches equals 900lbs. You can also have a dual rate spring which is two coils mounted to the shock. If the spring rates are equal on both coils your spring rate will be close to half that of each spring. As the coils compress equally the shock travels one inch but each coil only travels one half inch. Using our 300lb spring rate in the previous example if you have two 300lb springs and they each travel 1/2 inch then their combined force would be 150lbs.

You also have the option of more highly sophisticated dual rate configurations that use combinations of differently rated coils and secondary travel stops to give you non-linear spring rates. They can be softer initially and then reach higher levels of firmness than a linear coil of the same length. The variations and applications involved would require too lengthy an explanation to fit on this page but rest assured our experienced sales technicians can guide you through the process of configuring your shocks to provide the ultimate in ride comfort and control regardless of your application or driving style.



## KING FACTORY REPLACEMENT PARTS

King shocks are made from the finest materials available to provide years of trouble free service. Our shocks have evolved from pure racing designs so they are able to be tuned and serviced with simple hand tools. Any part on a King shock can be rebuilt or replaced with factory fresh pieces. When the time comes, convenient pre-packaged seal and shim kits as well as wear bands, bearings, shafts and shock oil are just a phone call away. All the parts that go into a King shock are identified below.

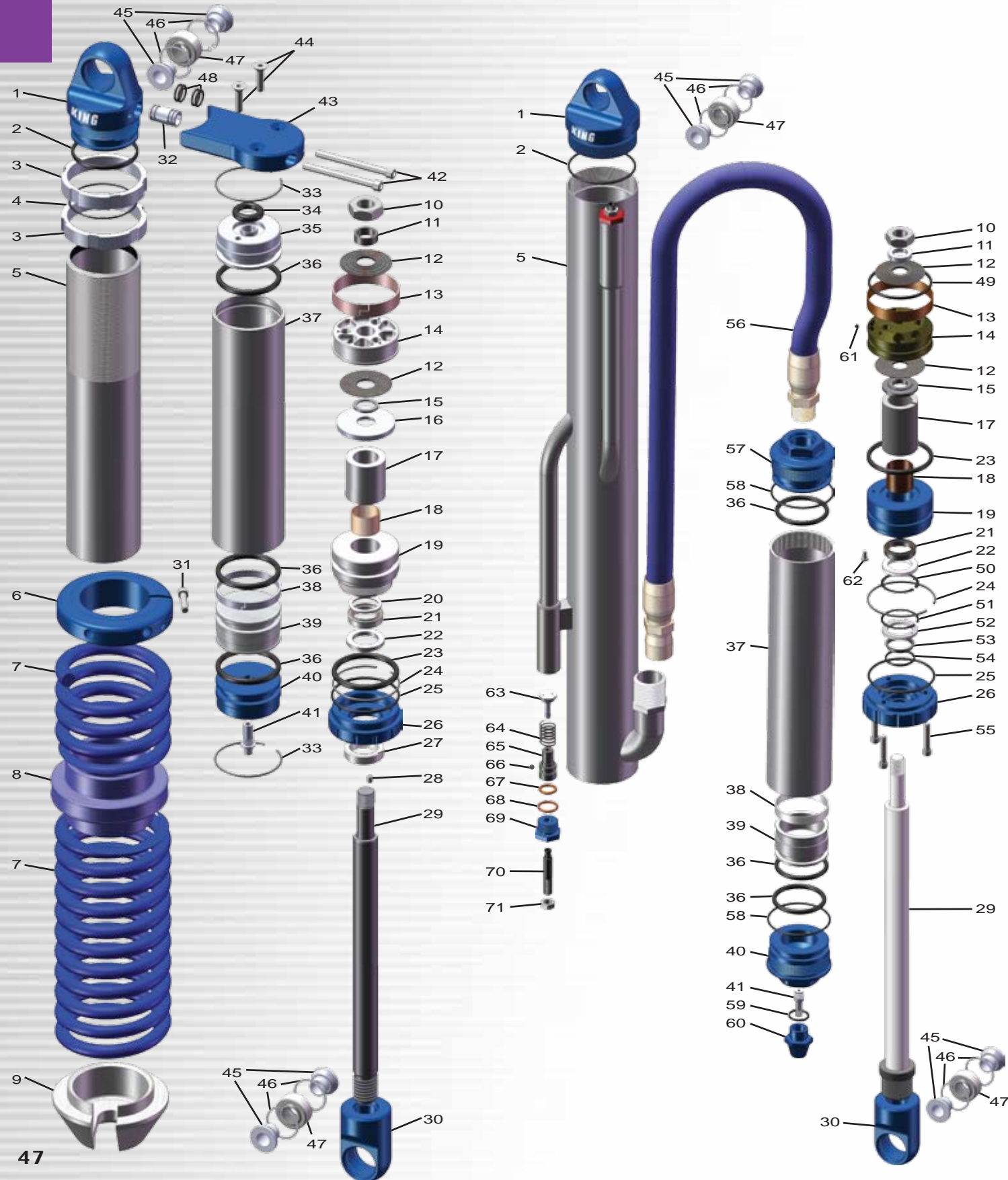

## Parts Glossary

- 1-Top Cap
- 2-Top Cap O-Ring
- 3-Secondary Nuts
- 4-Secondary Nut O-Ring
- 5-Shock Cylinder
- 6-Coil Adjustment Nut
- 7-Coil Spring
- 8-Coil Slider
- 9-Coil Plate
- 10-Piston Retaining Nut
- 11-Piston Retaining Washer
- 12-Valve Shims
- 13-Piston Wear band
- 14-Piston
- 15-Base Washer
- 16-Top Out Washer
- 17-Shaft Spacer
- 18-Shaft Guide / DU Bushing
- 19-Seal Cap
- 20-Shaft O-Ring
- 21-Main Seal
- 22-Main Seal Retainer
- 23-Seal Cap O-Ring
- 24-Shock Cylinder C-Clip
- 25-Wiper Cap O-Ring
- 26-Wiper Cap
- 27-Wiper Seal
- 28-Set Screw
- 29-Shock Shaft
- 30-Rod End
- 31-Coil Adjustment Pinch Bolt
- 32-Piggyback Mounting Sleeve
- 33-Reservoir C-Clip
- 34-Piggyback Adaptor O-Ring
- 35-Piggyback Reservoir Oil End Cap
- 36-Reservoir O-Rings
- 37-Reservoir Cylinder
- 38-Reservoir Piston Wear Band
- 39-Reservoir Piston
- 40-Remote Reservoir Air End Cap
- 41-Schrader Valve
- 42-Piggyback Mounting Plate Bolts
- 43-Piggyback Mounting Plate
- 44-Piggyback Reservoir End Cap Bolts
- 45-Spacer
- 46-Bearing C-Clips
- 47-Spherical bearing
- 48-Piggyback Mounting Sleeve O-Rings
- 49-Piston O-Ring
- 50-Main Seal C-Clip
- 51-Wiper Seal C-Clip
- 52-Wiper Seal Retainer
- 53-Wiper Seal
- 54-Wiper O-Ring
- 55-Wiper Cap Bolts
- 56-Remote Reservoir Hose
- 57-Remote Reservoir Oil End Cap
- 58-Remote Reservoir End Cap O-Ring
- 59-Schrader Valve Cap O-Ring
- 60-Schrader Valve Cap
- 61-Piston Bleed Screw
- 62-Seal Cap Bleed Screw
- 63-Bypass Valve
- 64-Bypass Spring
- 65-Bypass Valve Stop
- 66-Bypass Valve Stop Set Screw
- 67-Bypass Valve Stop O-Ring
- 68-Bypass Adjusting Nut O-Ring
- 69-Bypass Adjusting Nut
- 70-Bypass Adjusting Screw
- 71-Bypass Adjusting Jam Nut



**Gallon size King, high performance shock fluid.** Get the edge on your competition by running high quality, specially formulated, King shock oil. Shock Oil: Part # F10011 Air Shock oil: Part # F10012



### King seal replacement kit.

Rebuild your shocks with genuine factory replacement parts made from the proper materials for peak performance. **Multiple kit sizes available**



### King performance shim kit.

King valve shims are made from a unique stainless alloy that remains stable at high temperatures and does not crack like plain steel shims do. King shims are crucial to maintain proper, consistent performance from your King shocks. **Multiple sizes available**



### King piston wear bands.

King piston wear bands are made from Teflon impregnated bronze material unlike all others. They give you a higher level of safety and performance. **Multiple sizes available**



### Schrader valves.

High pressure, high temperature, precision made Schrader valves. CV2101-(short) CV2102-(long)



### Spherical bearing reducers/ spacers.

Properly locate your shocks while still allowing articulation with these spacers. Available to fit several bolt sizes and mounting tab widths. **Multiple sizes available**



### Cylinder and shaft clamping soft jaws.

Get a firm grip on shock bodies and shafts when doing service without scratches or dents. Part # 100-001-(3/4"shaft) 100-002-(7/8"shaft) 100-003-(1"shaft) 100-004-(1 1/4"shaft) 100-005-(2.0PR clamp) 101-002-(2.5PR clamp) 101-001-(2.5RS clamp) 101-004-(3.0RS clamp) 101-003-(2.5&3.0RES clamp)



### Coil nut adjusting spanner wrenches.

Beautifully anodized billet spanner wrenches for 2.0 and 2.5 diameter shock preload adjustments. Part # T1002-(2.0) T1002-002-(2.5)



### T-Handle coil nut adjuster wrench.

Make quick work of coil nut adjustments with this textured t-handled adjuster. One size for 3.0 and bigger and another for 2.0 and 2.5 inch shocks. Part # 25308-100-(2.0 & 2.5) 30313-100-(3.0)



### Standard coil nut adjuster wrench.

Simple, durable coil nut adjuster wrench for setting preload and ride height. Part # 25308-002

### Retaining ring pliers.

Quality, precision, German made snap ring pliers have comfortable padded grips. They come in two sizes to handle a range of snap ring diameters. Part # CR2901-(small) CR2902-(large)



### King shock charging manifold

Accurate 0-400 PSI pressure gage, easy to use manifold for precise shock charging. Part # T1001-100

### King assorted decal kit.

Show your pride in running the best shocks available with King decals. Part # D13001





## JOIN THE KING DEALER NETWORK

King Shocks, the leader in performance damping technology, is currently expanding their dealer network. Join the team that continuously leads the way with innovative designs and the most comprehensive customer support in the industry. King shocks are designed to allow custom tuning to suit your customer's vehicle and driving style. There are over 30 custom options available to provide your customers with endless choices when purchasing their King shocks. Applications are available for UTV's, bolt on OEM upgrades, Sand cars, 4X4's, custom applications and all out racing. As a dealer, you can attend King factory technical training to provide custom tuning and rebuilding to your customers, or concentrate on sales and rely on the existing factory provided services, the choice is yours.

King Shocks are made in the USA using the finest raw materials available under the strictest precision tolerances. Not only are they the best performing shocks, they are also exquisitely finished jewels that will add appeal to any vehicle. King's quality and value will help you gain a diversified, loyal, customer base with the high level of satisfaction that comes from owning the best. Inquire today about all the benefits of becoming an authorized dealer and servicer of King performance shock absorbers.

## THE KING SHOCK WARRANTY

King Shock Technology, (King Shocks), reserves the right to change or modify any of the products and their inherent physical and technical specifications without prior notice. King Shocks and affiliates assume no responsibility or liability for any errors or inaccuracies within. Products may not be exactly as displayed; prices and specs are subject to change without notice. Plating, anodizing and other coatings used are warranted to be free from defects at time of sale only. They may degrade over time depending on environmental conditions beyond the control of King Shocks. King Shocks' products are warranted to be free from manufacturing defects for a period of 90 days from date of purchase. The warranty does not cover; crash damage, abuse, modified and/or use of non- King parts, lack of maintenance or incorrect supplied dimensions and or specifications on custom orders. The user shall determine the suitability of the product for his or her intended use and shall assume all risk and liability in connection therewith.

**CARL RENEZEDER**  
MULTI-TIME SHORT COURSE CHAMPION