



# Installation Instructions Trektop Ultra

Vehicle Application:  
Jeep® JLU Wrangler Unlimited 2018 - Current  
Part Number 54925

## Installation Tips

Before you begin installing your new Supertop Ultra, please read all the instructions thoroughly.

### For a smooth fit:

For easier installation, the top should be installed at a temperature above 72°F. Below this temperature, the fabric may contract an inch or more, making it difficult to fit the vehicle.

It is normal for the fabric to contract and wrinkle when stored in the shipping carton. Within a few days after installation, the fabric will relax and the wrinkles will disappear.

**! WARNING** Do not rely in any way on the components of this product to protect against injury or death in the event of an accident. Never operate the vehicle in excess of manufacturer's specifications.

Read and follow, precisely, all installation instructions provided when installing this product. Failure to do so may result in a poor fit and could place occupants of the vehicle in a potentially dangerous situation.

**! CAUTION** Safety glasses should be worn at all times when installing this product.

**WEAR SEAT BELTS AT ALL TIMES**



Tools			
			<b>- AND -</b>
Safety Glasses	Ratchet	10mm Socket	10mm Wrench
			<b>- OR -</b>
Step Ladder	Torque Wrench	8mm Socket	8mm Wrench
Super Glue	Phillips Screwdriver	3mm-4mm-5mm Allen Wrenches	T8-T20-T25-T30-T40-T50 Torx Drivers
Flat Blade Screwdriver			

Installation Time	
	<b>4 hours</b>

Skill Level	
1	2
<b>3</b>	4
<b>3 - Moderately Difficult</b>	

Support
We're here to help! Go to: <a href="https://www.bestop.com">https://www.bestop.com</a> and click on <b>Need Help?</b>
<a href="https://www.bestop.com/video-library">https://www.bestop.com/video-library</a>



## Installation Instructions Trektop Ultra

Vehicle Application:  
Jeep® JLU Wrangler Unlimited 2018 - Current  
Part Number 54925

### Sugerencias de Instalación

**Antes de empezar a instalar esta unidad, lea atentamente todas las instrucciones.**

**Para un buen ajuste:**

Para facilitar la instalación, el producto debe instalarse a temperaturas superiores a 72 °F (22 °C).

Por debajo de esta temperatura, la tela puede encogerse una pulgada o más, lo que dificultaría su ajuste al vehículo.

Es normal que la tela se contraiga o arrugue cuando está guardada en la caja de empaque. A los pocos días después de la instalación, la tela se relajará y las arrugas desaparecerán.



#### ADVERTENCIA

Este producto se diseñó principalmente para mejorar la apariencia del vehículo y proteger a los ocupantes de las condiciones climáticas comunes. De ninguna manera piense que los componentes de este producto pueden servir como medio de contención para los ocupantes del vehículo o que pueden protegerlos contra lesiones o la muerte en caso de accidente. Este producto no protegerá a los ocupantes contra caídas de objetos. Nunca conduzca este vehículo fuera de las especificaciones del fabricante.

#### USE LOS CINTURONES DE SEGURIDAD EN TODO MOMENTO

Lea y siga con precisión todas las instrucciones de instalación que se proporcionan para instalar este producto. Si no lo hace, podría producirse un mal ajuste que colocaría a los ocupantes del vehículo en una situación potencialmente peligrosa.



#### PRECAUCIÓN

Debe usar gafas protectoras en todo momento durante la instalación de este producto.

### Conseils pour l'installation

**Lire toutes les instructions au complet avant de commencer l'installation de cet assemblage.**

**Pour un ajustement sans problème :**

Afin de faciliter l'installation, ce produit doit être installé à des températures au-dessus de 72 °F (22 °C).

Sous cette température, le tissu peut rétrécir d'un pouce (2,5 cm) ou plus, ce qui rendra l'ajustement sur le véhicule difficile.

Il est normal que le tissu rétrécisse et plisse pendant qu'il est dans la boîte d'expédition. En quelques jours après l'installation, le tissu se détendra et les plis disparaîtront.



#### AVERTISSEMENT

Ce produit est conçu principalement pour améliorer l'apparence du véhicule et pour protéger les occupants des conditions météorologiques usuelles. Ne jamais se fier aux composants de ce produit pour se protéger de blessures ou de la mort en cas d'accident. Ce produit ne protégera pas les occupants des chutes d'objets. Ne jamais utiliser le véhicule au-delà des caractéristiques techniques indiquées par le fabricant.

#### PORTER UNE CEINTURE DE SÉCURITÉ EN TOUT TEMPS

Lire et suivre, très fidèlement, toutes les instructions d'installation fournies lors de l'installation de ce produit. Ne pas suivre cette consigne peut causer une installation inadéquate et mettre les occupants du véhicule dans une situation potentiellement dangereuse.



#### MISE EN GARDE

Des lunettes de sécurité doivent être portées en tout temps lors de l'installation de ce produit.









# Installation Instructions Trektop Ultra

Vehicle Application:  
Jeep® JLU Wrangler Unlimited 2018 - Current  
Part Number 54925

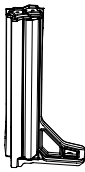
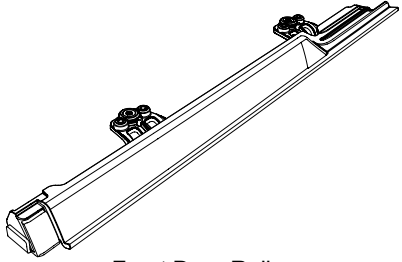
## Parts List

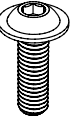
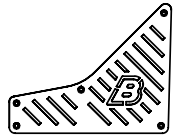
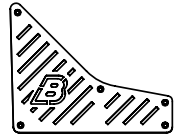
- Required parts for installation - Page number in Installation Guide

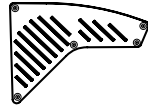
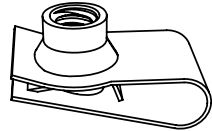
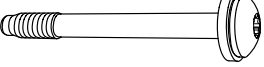
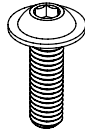
Sections 1 to 3		Rear Door Rails, Upper and Lower; Front Door Rails		Pages 7 to 9 of Guide
				
Upper Rear Door Rail Part #585.94 - Right Qty. 1	Upper Rear Door Rail Part #585.95 - Left Qty. 1	Lower Rear Door Rail Part #574.46 - Right Part #574.47 - Left Qty. 1		Front Door Rail Part #574.32 - Right (shown) Part #574.33 - Left Qty. 1 of each

Sections 1 to 3		Parts Kit #574.62			Pages 7 to 9 of Guide
<b>Parts Kit #574.62</b>					
	M6x20mm Flanged Button Head Cap Screw #517.48 Qty. 4		Lower Rear Door Rail Grille #579.00 - Right Qty. 1		Lower Rear Door Rail Grille #579.01 - Left Qty. 1
	M3.5x6 Screw #574.44 Qty. 20		Upper Rear Door Rail Grille #578.96 Qty. 2		M6 U-Clip #537.49 Qty. 4
	M8 x 1.25 x 80 Screw #532.23 Qty. 8		M8x1.25x20mm Flanged Button Head Cap Screw #573.09 Qty. 2		M8 Flat Washer #515.84 Qty. 2





# Installation Instructions Trektop Ultra

Vehicle Application:  
Jeep® JLU Wrangler Unlimited 2018 - Current  
Part Number 54925

## Parts List

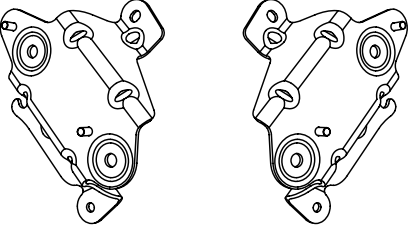
- Required parts for installation - Page number in Installation Guide

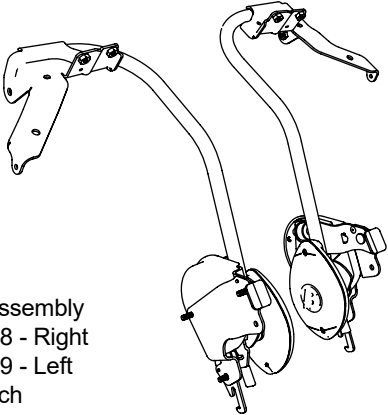
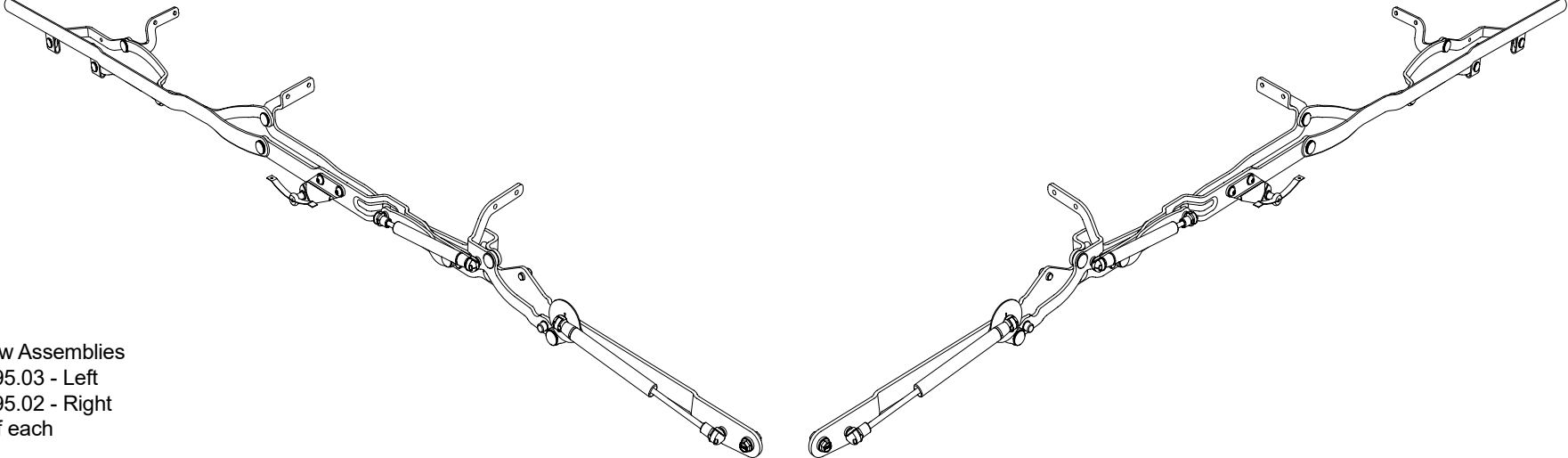
Sections 4 to 6	Sport Bar Brackets, Tailgate Bar Retainers, Lift Assist	Pages 10 to 12 of Guide
 <p>Sport Bar Mounting Brackets Part #590.02 - Right Part #590.03 - Left Qty. 1 of each</p>	 <p>Tailgate Bar Retainers Part #575.39 - Left Part #575.38 - Right Qty. 1 of each</p>	 <p>Lift Assist Assembly Part #595.18 - Right Part #595.19 - Left Qty. 1 of each</p>
Sections 7 to 9	#6 Bow, #5 Bow, #5 Bow Pivot Brackets, Side Bow Assemblies	Pages 13 to 15 of Guide
 <p>Side Bow Assemblies Part #595.03 - Left Part #595.02 - Right Qty. 1 of each</p>		





# Installation Instructions Trektop Ultra

Vehicle Application:  
Jeep® JLU Wrangler Unlimited 2018 - Current  
Part Number 54925

## Parts List

- Required parts for installation - Page number in Installation Guide

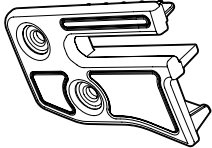
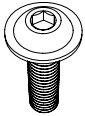
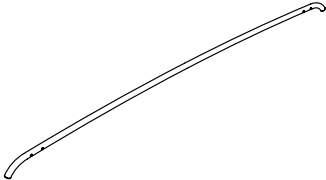
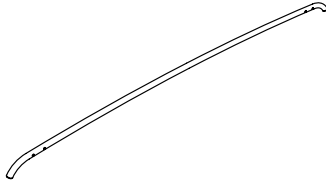
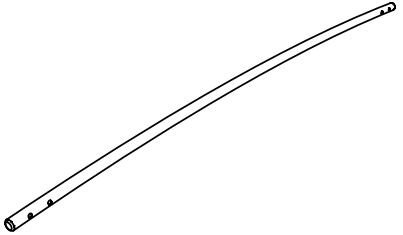
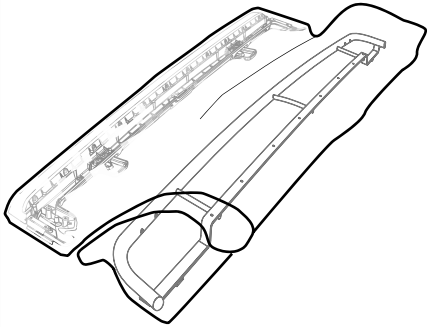
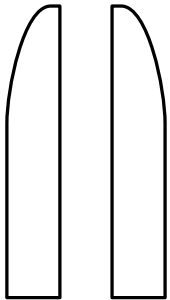
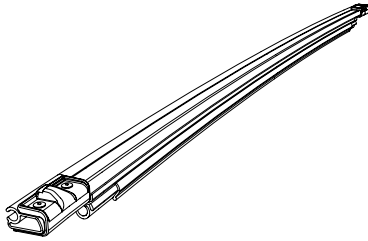
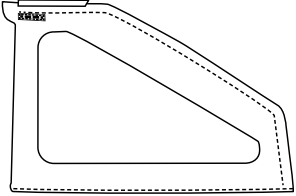
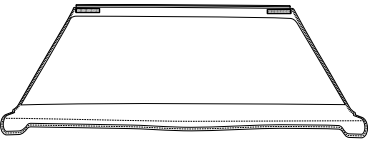
Sections 10 to 12		Rear Door Rail Covers, #4 Bow, #3 Bow, #2 Bow		Pages 16 to 18 of Guide
<div style="border: 1px solid black; padding: 5px; display: inline-block;"><b>Parts Kit #585.93</b></div>				
 <p>Rear Door Rail Covers Part #589.48 - Right Part #589.49 - Left (shown) Qty. 1 of each</p>  <p>M6 x 1.0 x 10mm Flanged Allen Screw Part #572.83 Qty. 4</p>		 <p>#4 Bow Part #583.03 Qty. 1</p>	 <p>#3 Bow Part #583.01 Qty. 1</p>	 <p>#2 Bow Part #582.99 Qty. 1</p>
Sections 13 to 25		Bow-Fabric Deck, Foam Seals, Tailgate Bar, Windows		Pages 19 to 31 of Guide
 <p>#1 Bow/#5 Bow and Fabric Deck assembly Part #595.50 Qty. 1</p>	 <p>Foam Seals Part #573.20 (right) Part #573.21 (left) Qty. 1 of each</p>	 <p>Tailgate Bar Part #575.33 Qty. 1</p>	 <p>Quarter Windows Left and Right Qty. 1 of each</p>  <p>Rear Window Qty. 1</p>	



# Installation Instructions Trektop Ultra

Vehicle Application:  
Jeep® JLU Wrangler Unlimited 2018 - Current  
Part Number 54925

## Parts List

- Required parts for installation - Page number in Installation Guide

### All Sections

### Small Parts Kit #594.85

### Multiple Pages

#### Parts Kit #587.70

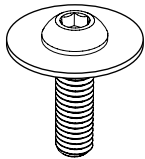

M8x1.25x28  
Button Head  
Socket Cap  
Screw/Washer  
Part #534.24  
Qty. 4

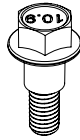

M6 Shoulder Screw  
Part #586.72  
Qty. 2

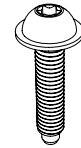

M6x1.0x25  
Flanged Torx Screw  
Part #535.23  
Qty. 12

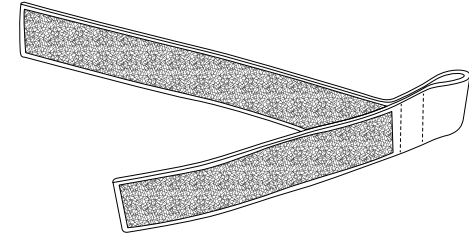

Lift Assist Tie-Down Strap  
Part #590.76  
Qty. 2

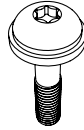

M8x1.25x38  
Button Head  
Socket Cap  
Screw/Washer  
Part #532.17  
Qty. 2



Thick Plastic Bushing  
Part #570.42  
Qty. 2



M6x20mm Screw  
M6 X 1.0 X 20  
Flanged Button  
Head  
#533.84  
Qty 4



Thin Plastic Bushing  
Part #532.78  
Qty. 2

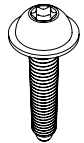

M6x1.0x30  
Flanged Torx Screw  
Part #533.19  
Qty. 4

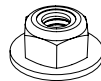

M6 Flanged Nut  
Part #591.47  
Qty. 4

#### Parts Kit #599.02

#### Trektop Ultra Kit Small Parts #599.02

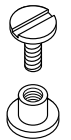

Screw-Binding Barrel  
Part #599.01  
Qty. 2

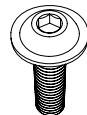

M6 x 1.0 x 10mm  
Flanged Allen Screw  
Part #572.83  
Qty. 4

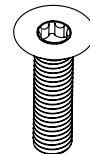

M5 x 0.8 x 22  
Flanged Torx Screw  
Part #579.61  
Qty. 6

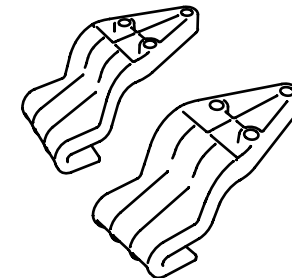

Stiffener Clips  
Part #595.14 - Right  
Part #595.15 - Left  
Qty. 1 of each



Sheet Metal  
Screw  
Part #393.79  
Qty. 2



Plastic Push Pin  
Part #533.96  
Qty. 2



M5 Flat Washer  
#565.90  
Qty. 6



M5 Nyloc Nut  
Part #526.76  
Qty. 6

<b>Step 1</b>	537.49	585.94	585.95
---------------	--------	--------	--------

**Hardware**

<b>Step 2</b>	574.46	574.47	517.48
---------------	--------	--------	--------

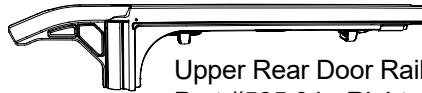
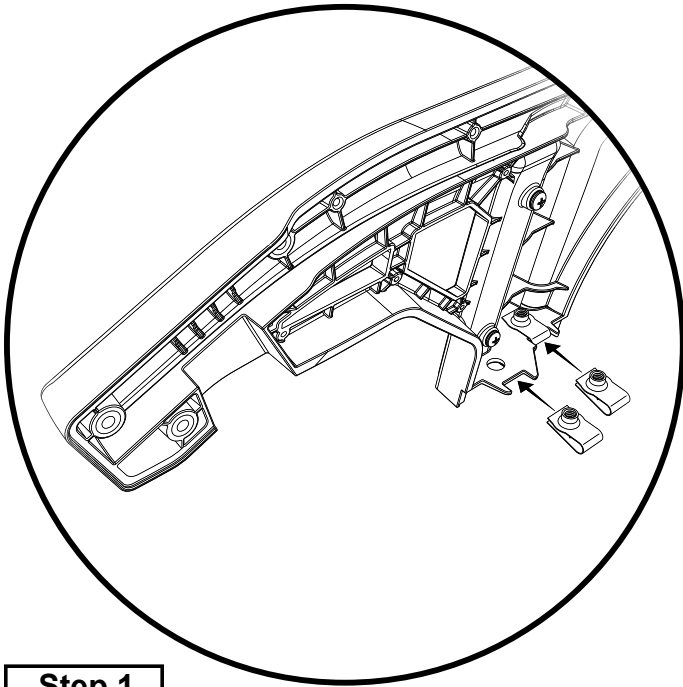

Upper Rear Door Rail  
Part #585.94 - Right  
Part #585.95 - Left  
Qty. 1 of each



Lower Rear Door Rail  
Part #574.46 - Right  
Part #574.47 - Left  
Qty. 1 of each

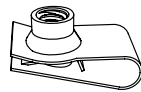

M6 U-Clip  
#537.49  
Qty. 4

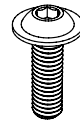

M6x20mm  
Flanged Button Head  
Cap Screw  
#517.48  
Qty. 4

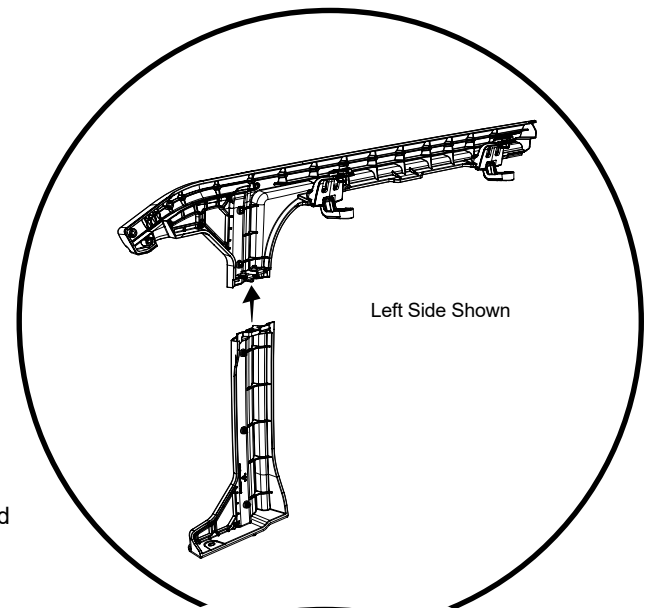

**Step 1**

Attach the two (2) U-Clips #537.49 to the Upper Rear Door Rails #585.94 (right) and #585.95 (left) in the positions indicated. Make sure to have the threaded barrel of each U-Clip facing up.

**Tools**



4mm  
Allen Wrench

**Step 2**

Attach the Upper Rear Door Rail #585.94 (right) to the Lower Rear Door Rail #574.46 (right).

Attach the Upper Rear Door Rail #585.95 (left) to the Lower Rear Door Rail #574.47 (left).

Use two (2) #517.48 Button Head Cap Screws (can be found in Small Parts Kit #574.62) per assembly.

Screws thread up from the bottom into the U-Clips.

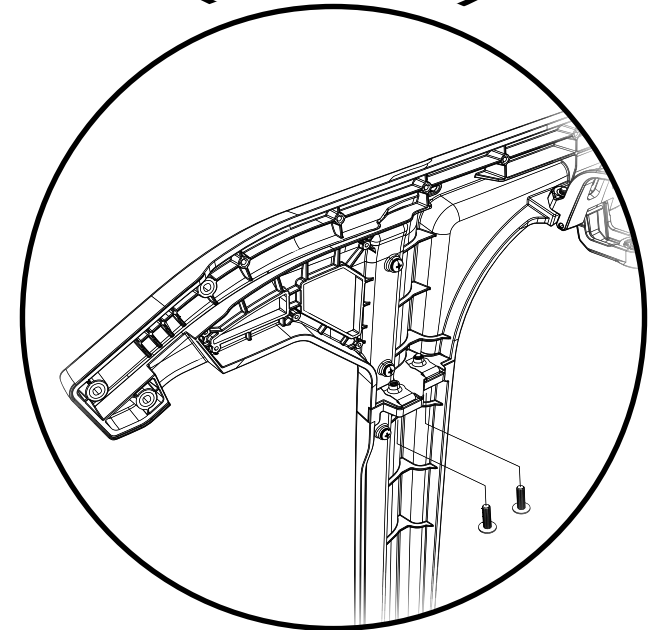

<b>Step 1</b>	579.00	579.01	578.96	574.44
---------------	--------	--------	--------	--------

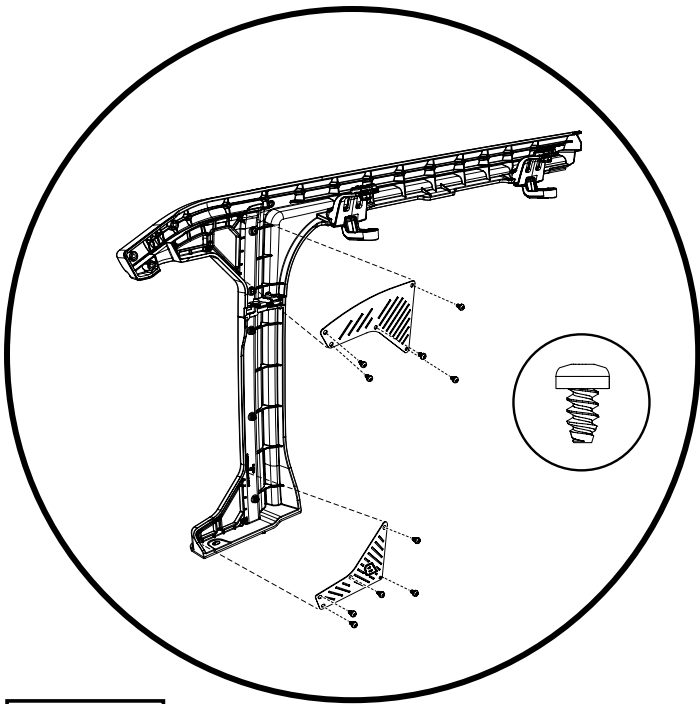

**Step 1**

Attach the Upper Rear Door Rail Grilles #578.96 to each Rear Door Rail Assembly using five (5) #574.44 screws for each grille. These grilles are the same on each side.

Attach the Lower Rear Door Grille #579.00 (right) to the Right Rear Door Rail Assembly, using five (5) #574.44 screws for each grille.

Attach the Lower Door Rail Grille #579.01 (left) to the Left Rear Door Rail Assembly, using five (5) #574.44 screws for each grille.

**Hardware**

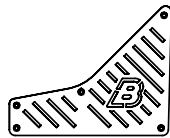

Lower Rear Door Rail Grille #579.00 - Right Qty. 1

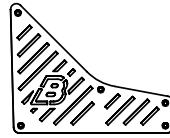

Lower Rear Door Rail Grille #579.01 - Left Qty. 1

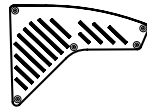

Upper Rear Door Rail Grille #578.96 Qty. 2



M3.5x6 Screw #574.44 Qty. 20

**Tools**



T8 Torx Driver

<b>Step 1</b>	532.23	573.09	515.84
---------------	--------	--------	--------

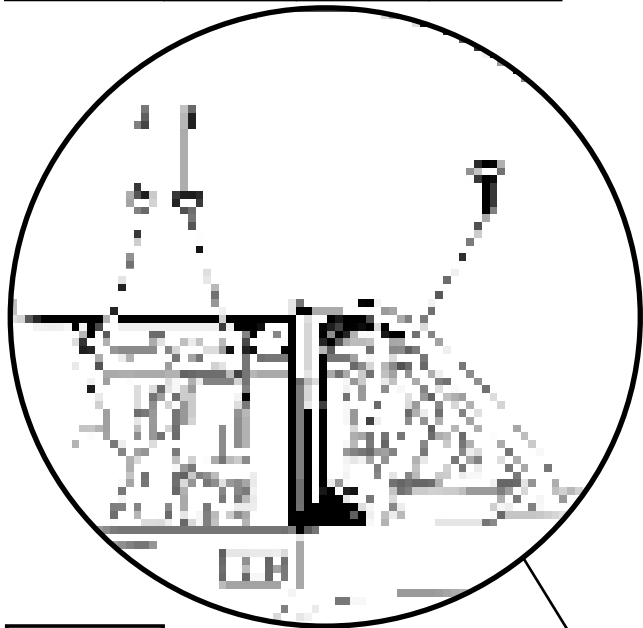

**Step 1**

Attach the Rear Door Rail Assemblies to the Jeep. Place each Rear Door Rail Assembly onto the Jeep just behind the rear door.





Align the hole in the lower portion of the Assembly with the threaded hole in the Jeep belt rail, the alignment pin on the bottom of the Assembly with the receiving hole in the top of the belt rail, and the two integral brackets along the top of the Assembly with the through-holes in the Jeep Sport Bar.

Insert two (2) M8x1.25x80 Screws #532.23 up from the bottom of the integral brackets and tighten to 55 in/lb (4.5 ft/lb).

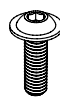

Use one (1) M8x1.25x20 screw #573.09 and one (1) M8 Flat Washer #515.84 on each Assembly to secure the Assembly to the Jeep belt rail.

**Note:** To prevent over torquing, Use a Screwdriver type Torx driver if a torque wrench is not available.

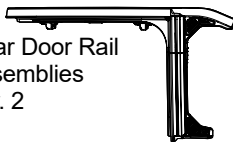
**Hardware**

-  M8 x 1.25 x 20 Screw #573.09 Qty. 2
-  M8 x 1.25 x 80 Screw #532.23 Qty. 8
-  M8 Flat Washer #515.84 Qty. 2
-  Front Door Rail Part #574.33 - Left Part #574.32 - Right Qty. 1
-  Rear Door Rail Assemblies Qty. 2

**Tools**

-  Torque Wrench
-  T40 Torx Driver

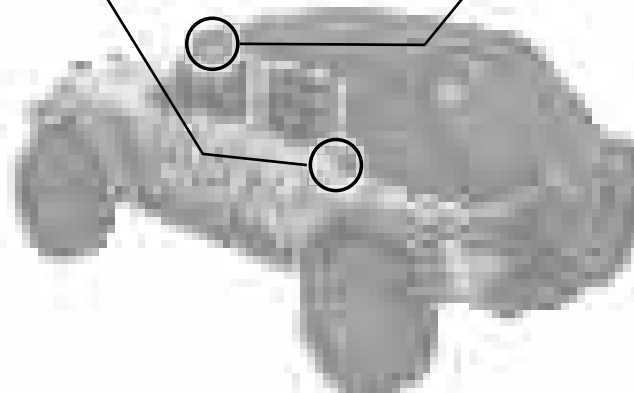

<b>Step 2</b>	532.23	574.32	574.33
---------------	--------	--------	--------

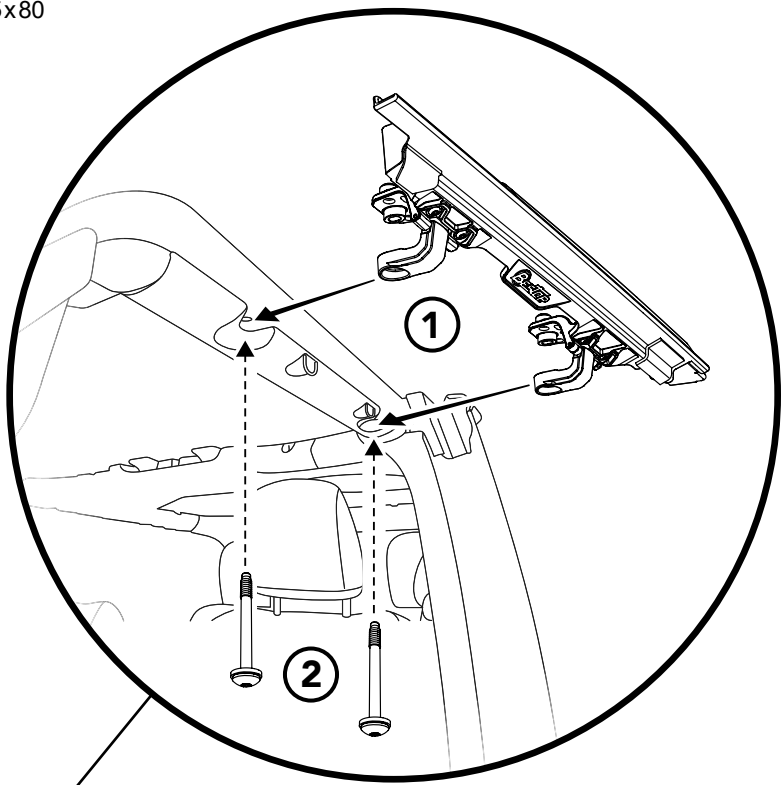

**Step 2**

Attach the Front Door Rails to the Jeep.

① Place each Front Door Rail #574.32 (left) and #574.33 (right) on the Jeep, aligning the rail brackets with the through-holes in the Jeep sport bar.

② Secure each Front Door Rail to the sport bar using two (2) M8x1.25x80 Socket Cap Screws #532.23. Insert the screws from the bottom and tighten to 55 in/lb (4.5 ft/lb).

**Note:** To prevent over torquing, Use a Screwdriver type Torx driver if a torque wrench is not available.

**Step 1**

**Hardware**

**Step 2** 590.02 590.03 534.24

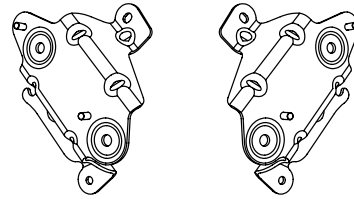
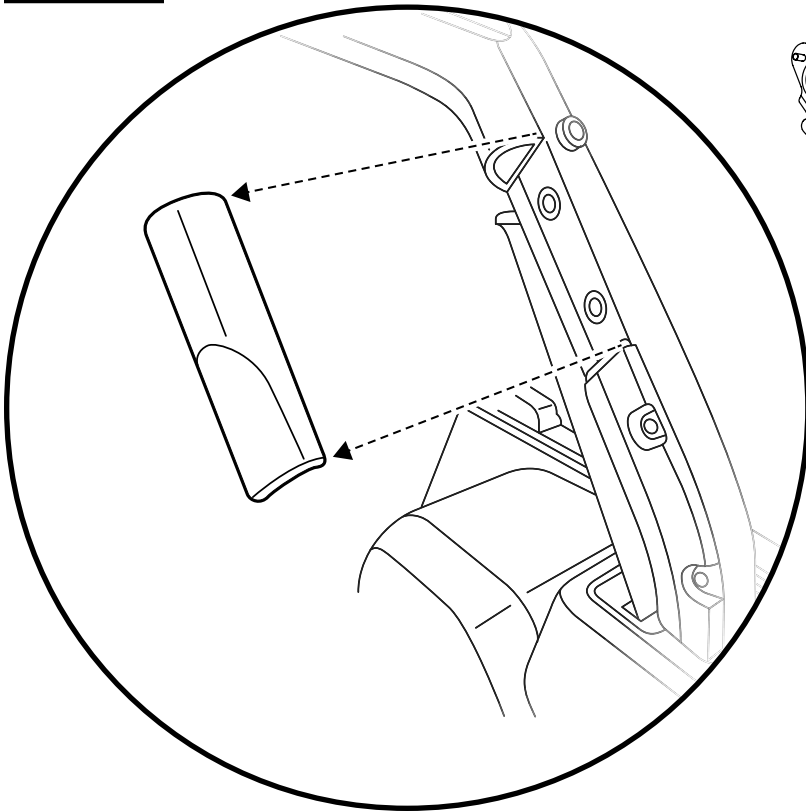

Sport Bar Mounting Brackets  
Part #590.02 - Right  
Part #590.03 - Left  
Qty. 1 of each

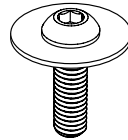

M8x1.25x28  
Button Head  
Socket Cap  
Screw/Washer  
Part #534.24  
Qty. 4

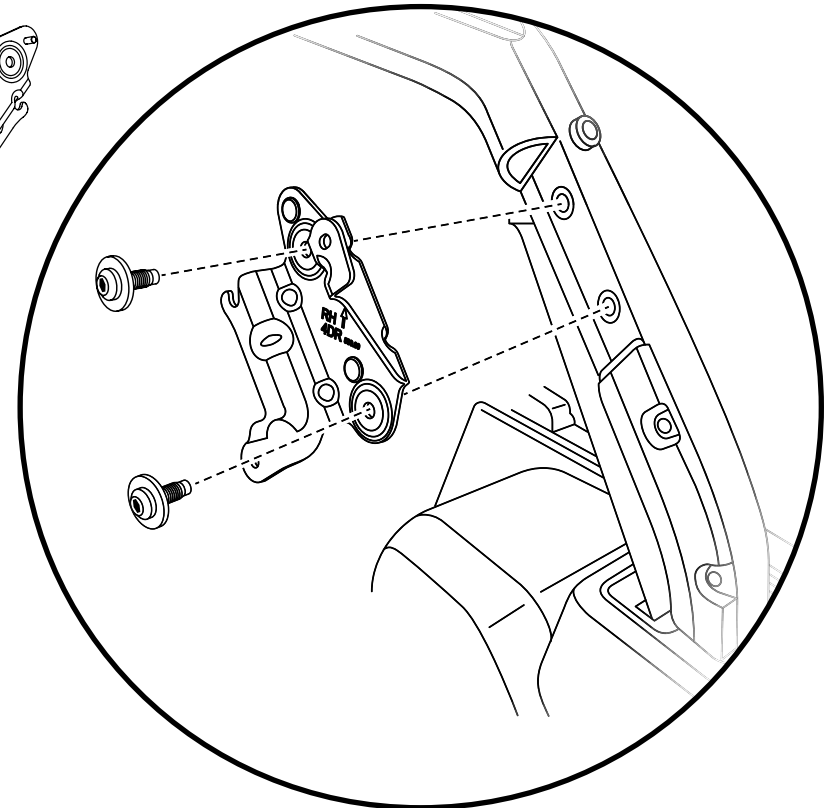

**Step 1**

Snap off the trim panel on the rear downtube of the Sport Bar on each side.

**Tools**



T40 Torx Driver

**Step 2**

Attach the Sport Bar Mounting Brackets #590.02 (right) and #590.03 (left) to the Sport Bar downtubes as shown, using two (2) #534.24 M8x1.25x28 Button Head Socket Cap Screw/Washers per bracket.

Attach brackets to both left and right side sport bar rear downtubes.

<b>Step 1</b>	575.38	575.39	532.17
---------------	--------	--------	--------

**Hardware**

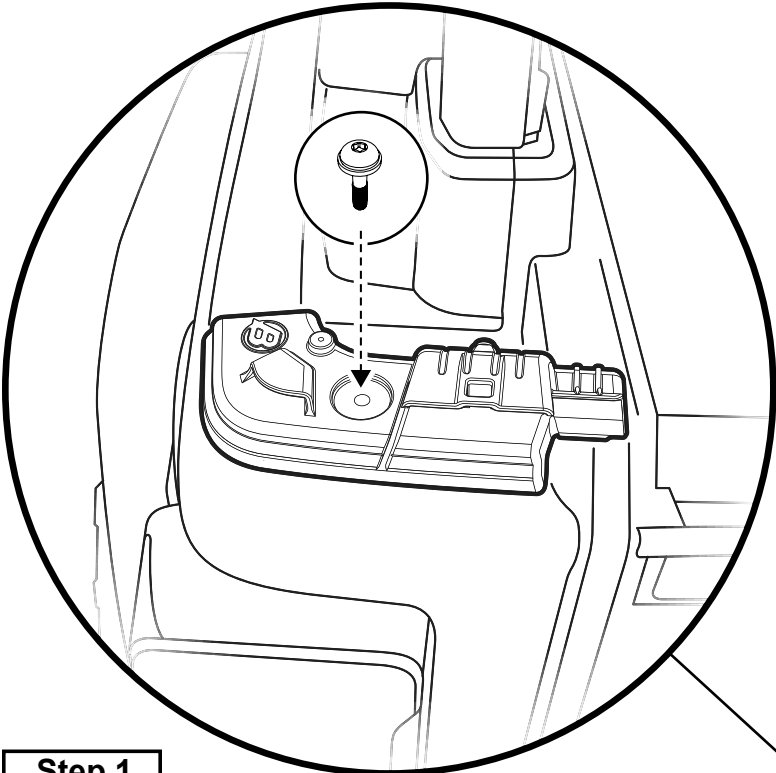

Tailgate Bar Retainer  
Part #575.38 - Right  
Qty. 1



Tailgate Bar Retainer  
Part #573.39 - Left  
Qty. 1

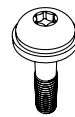

M8x1.25x35  
Button Head Socket  
Cap Screw  
#532.17  
Qty. 2

**Tools**



T50 Torx Driver

**Step 1**

Attach the Tailgate Bar Retainers #575.38 (right) and #575.39 (left) to the Jeep Belt Rail, using one (1) M8x1.25x38 Button Head Socket Cap Screw #532.17 per retainer.

Insert the screws through the retainers, and into threaded holes in the top of the Jeep belt rail, and tighten.

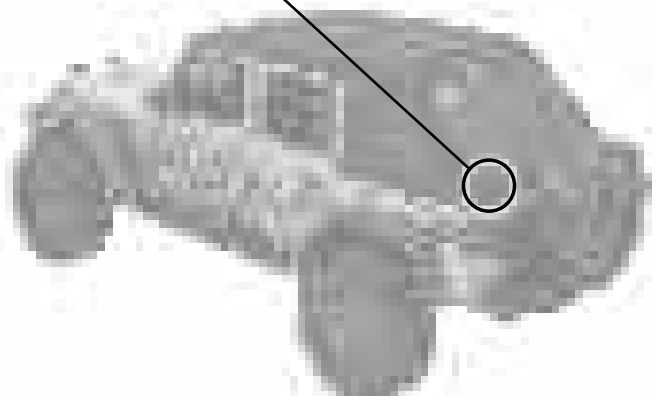

<b>Step 1</b>	595.18	595.19	590.76
---------------	--------	--------	--------

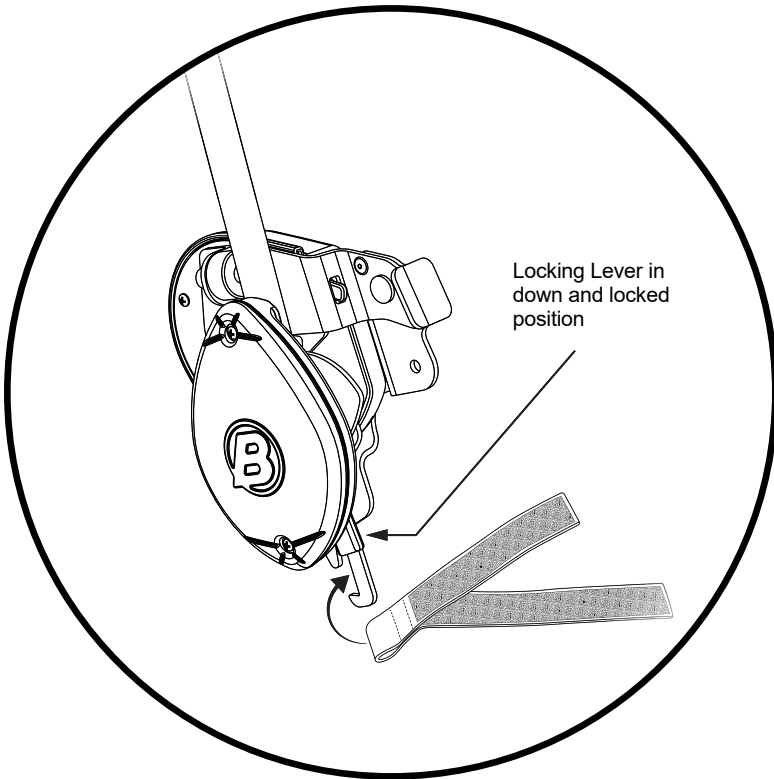

**Step 1**

Before attaching the Lift Assist Assemblies #595.18 and #595.19 to the Sport Bar Mounting Brackets, make sure that the yellow Locking Lever is in the down and locked position.

Slide the Lift Assist Tie-Down Straps #590.76 over the hooked tabs at the bottom of each lift assist assembly.

**Hardware**

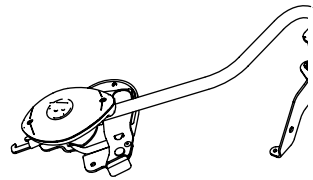

Lift Assist Assembly  
Part #595.19 - Left  
Part #595.18 - Right (shown)  
Qty. 1 of each

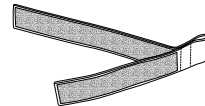

Lift Assist  
Tie-Down Strap  
Part #590.76  
Qty. 2



M6 Flanged Nut  
Part #591.47  
Qty. 4



M6x20mm Screw  
M6 X 1.0 X 20  
Flanged Button  
Head  
#533.84  
Qty 4

**Tools**

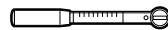

Torque Wrench



10mm Wrench



T25 Torx Driver

<b>Step 2</b>	595.18	595.19	533.84	591.47
---------------	--------	--------	--------	--------

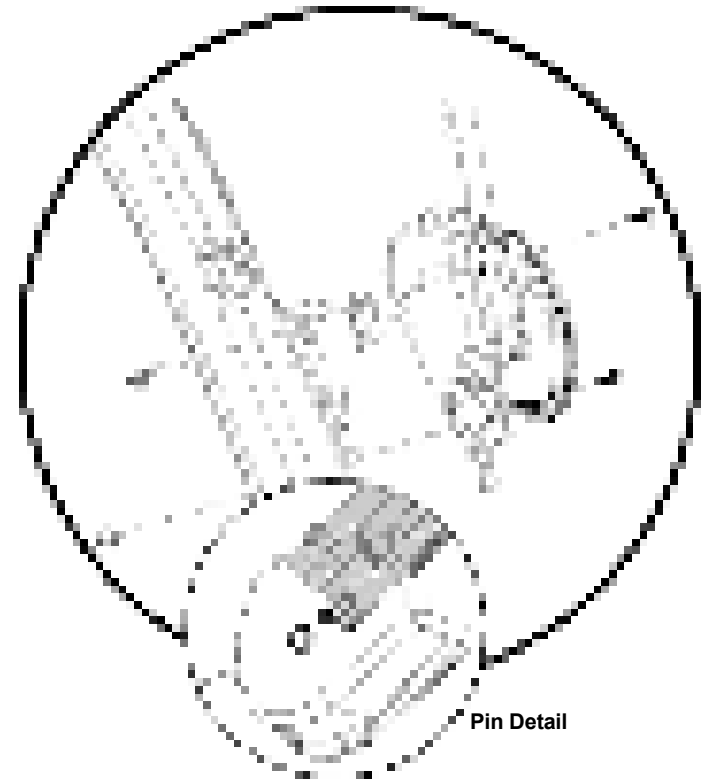

**Step 2**

Attach the Right Lift Assist Assembly #595.18 to the right side Sport Bar Mounting Bracket #590.02. Secure with the 2ea. 591.47 Flange nuts and the 2ea. 533.84 Flanged Button Head bolts.

NOTE: Be sure the pin in the lift assist goes into the slot in the mounting bracket. (See Detail)

Repeat on the left side of vehicle.

**Leave these fasteners only loosely attached** at this time. You will tighten them later in the installation process.



**Step 1** 595.02 595.03

**Hardware**

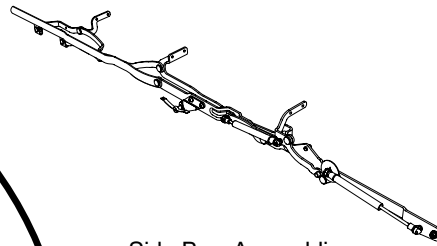
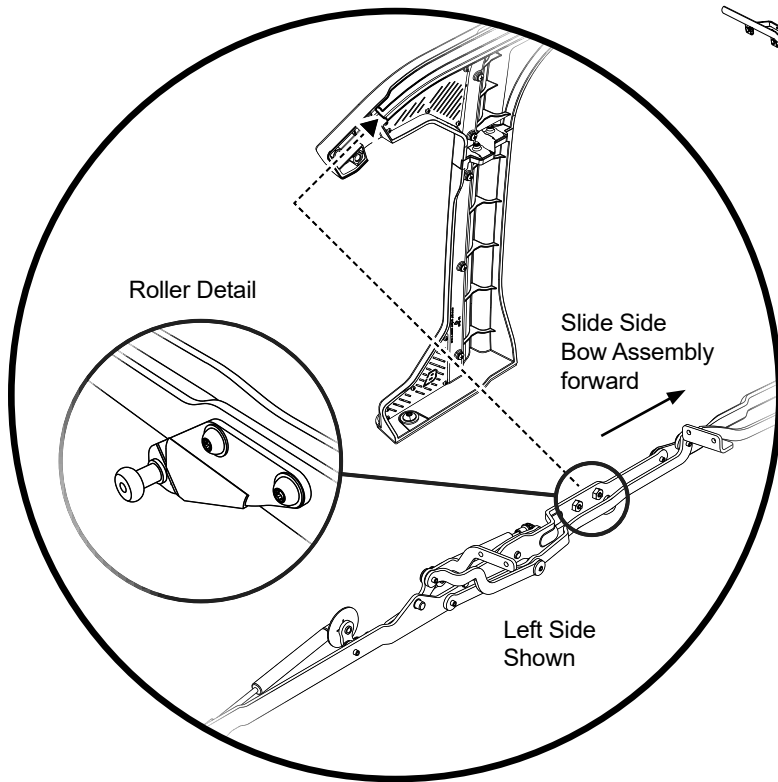

Side Bow Assemblies  
 Part #595.02- Right  
 Part #595.03 - Left (shown)  
 Qty. 1 of each

**Step 1**

Locate the roller on the outside of each Side Bow Assembly #595.02 (right and #595.03 (left).

**NOTE:** tabs for attaching roof bows face to the inside.

Insert the roller into the open end of the channel at the rear on the inside of each Rear Door Rail, and slide the Side Bow Assembly forward until it stops.

**Step 1**

586.72

570.42

532.78

**Hardware**

M6 Shoulder Screw  
Part #586.72  
Qty. 2



Thick Plastic Bushing  
Part #570.42  
Qty. 2



Thin Plastic Bushing  
Part #532.78  
Qty. 2

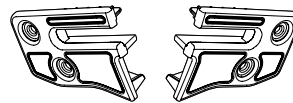

Rear Door Rail Cover Plates  
Part #589.48 - Right  
Part #589.49 - Left  
Qty. 1 of each



M6 x 1.0 x 10mm  
Flanged Allen Screw  
Part #572.83  
Qty. 4

**Tools**

10mm Wrench

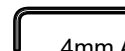

4mm Allen  
Wrench

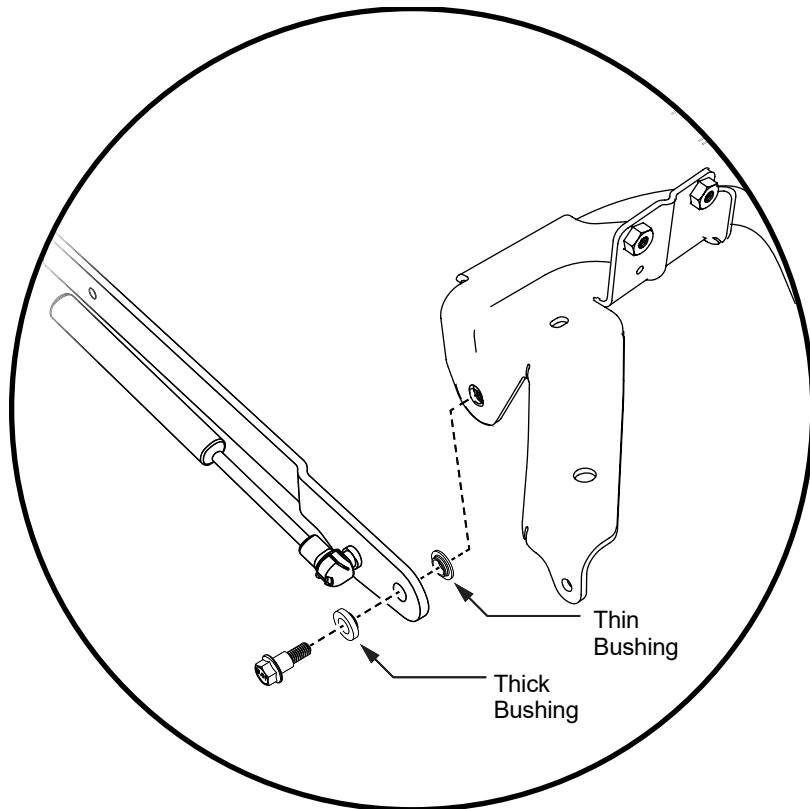
**Step 1**

Attach the pivot point at the rear of each Side Bow Assembly to the Pivot Bracket on each end of the Lift Assist Bracket..

Secure using one (1) Shoulder Screw #586.72, one Thick Plastic Bushing #570.42, and one Thin Plastic Bushing #532.78 per side.

The Thick Plastic Bushing goes to the outside.

Left side shown. Repeat on right side.

**Step 2**

589.48

589.49

572.83

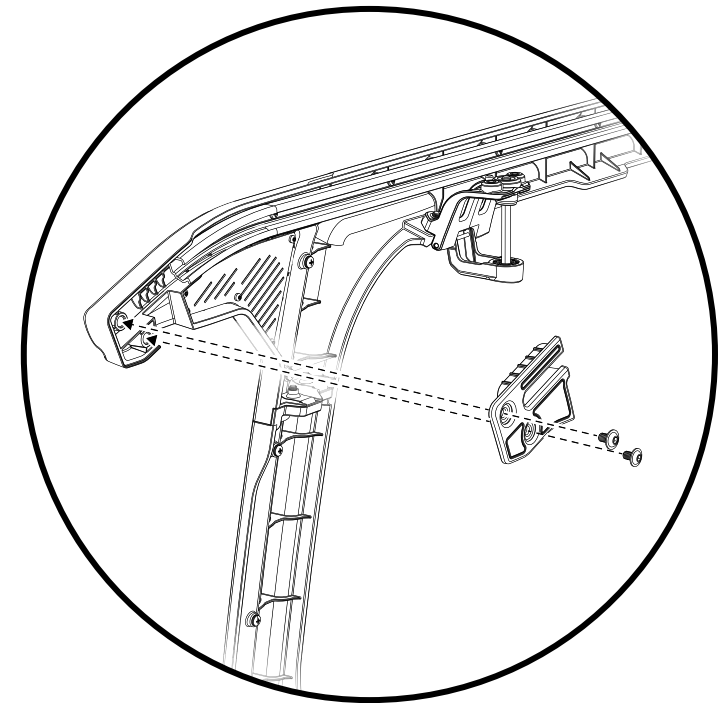
**Step 2**

Attach the Rear Door Rail Cover Plates #589.48 (right) and #589.49 (left) to each Rear Door Rail Assembly using two (2) #572.83 screws for each Cover Plate.

Left side shown.

**Step 1**    583.03    535.23

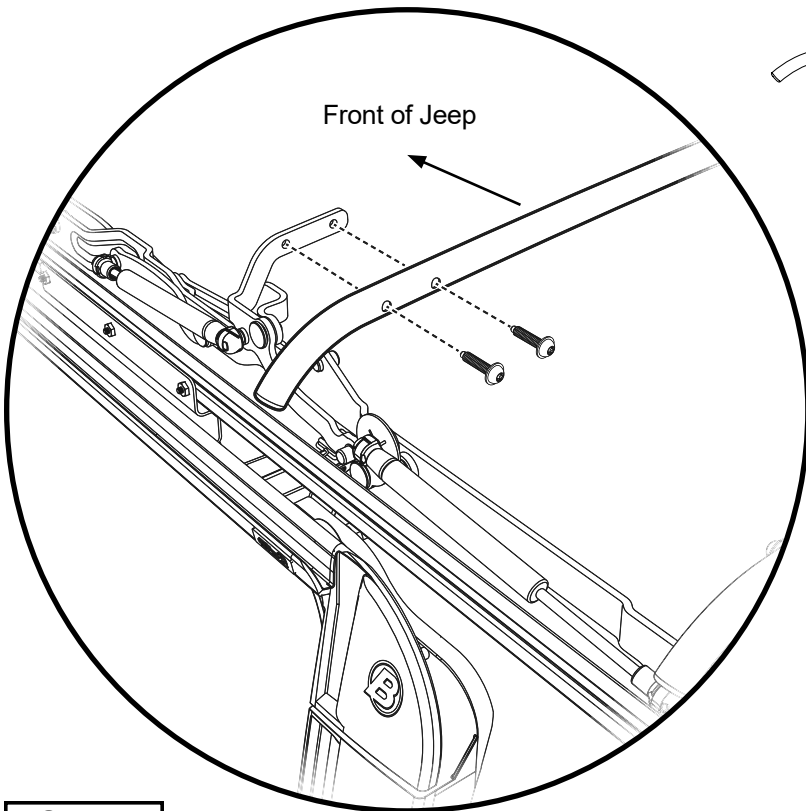

**Step 1**

Attach the #4 Bow #583.03 to the tabs on the Side Bow Assembly (just above the Rear Door Rails), using two (2) M6x1.0x25 Flanged Torx Screw #535.23 per side.

Note that the #4 Bow is attached to the rear-facing side of the tabs.

**Hardware**

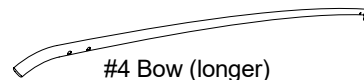

#4 Bow (longer)  
Part #583.03  
Qty. 1



#3 Bow (shorter)  
Part #583.01  
Qty. 1

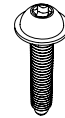

M6x1.0x25  
Flanged Torx Screw  
Part #535.23  
Qty. 8

**Tools**



T30 Torx Driver

**Step 2**    583.01    535.23

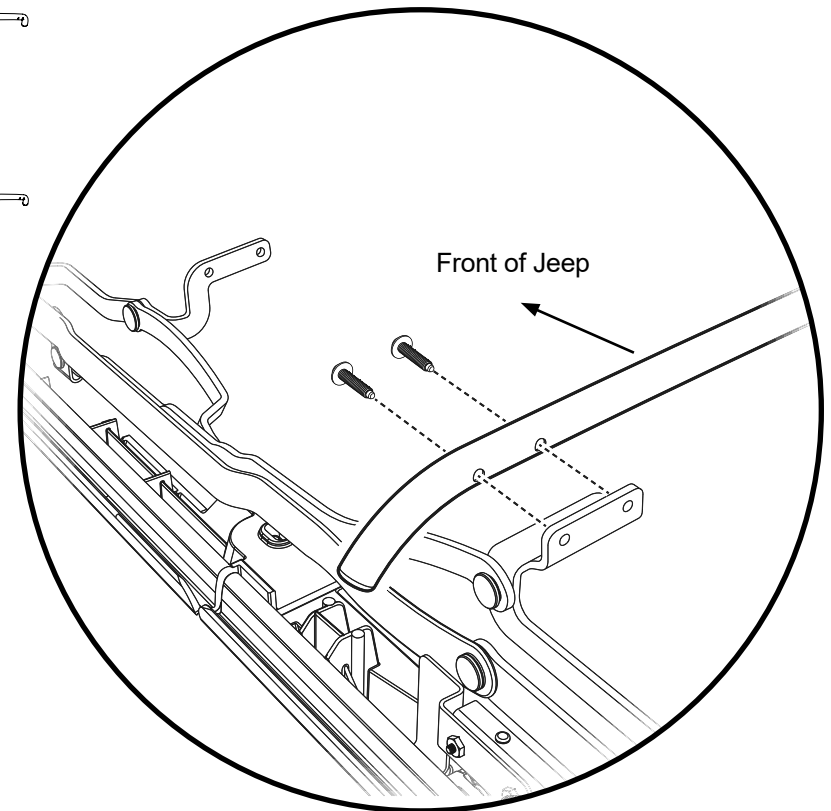

**Step 2**

Attach the #3 Bow #583.01 to the tabs on the Side Bow Assembly (just above where the Front Door Rails join the Rear Door Rails), using two (2) M6x1.0x25 Flanged Torx Screw #535.23 per side.

Note that the #3 Bow is located on the forward-facing side of the tabs.

Step 3

582.99

535.23

Hardware

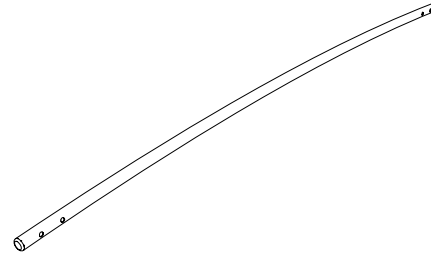
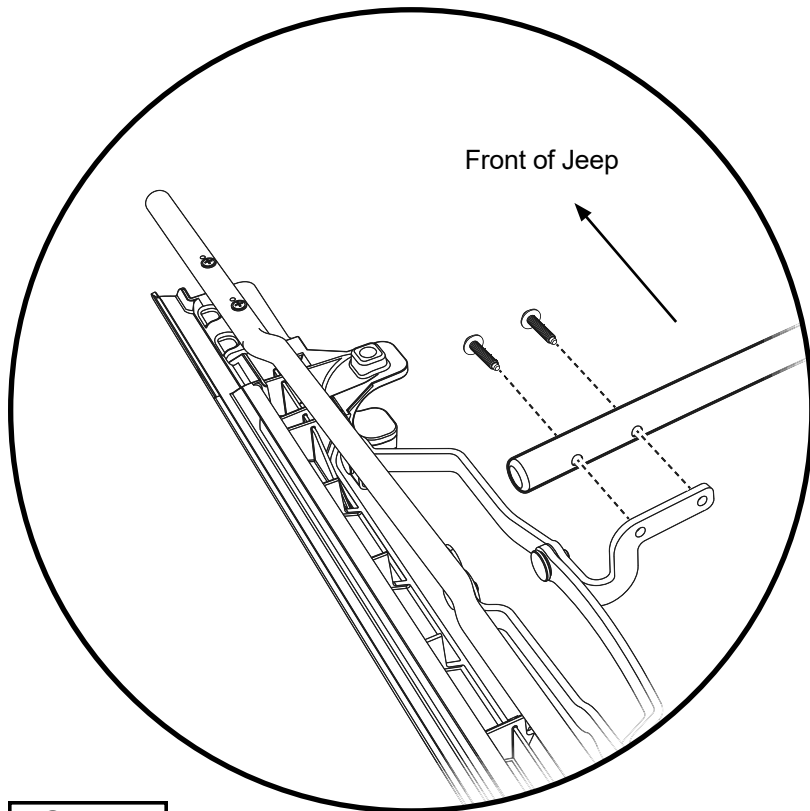

#2 Bow  
Part #582.99  
Qty. 1

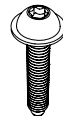

M6x1.0x25  
Flanged Torx Screw  
Part #535.23  
Qty. 4

Step 3

Attach the #2 Bow #582.99 to the tabs on the Side Bow Assembly, using two (2) M6x1.0x25 Flanged Torx Screws #535.23 per side.

Note that the #2 Bow attaches to the forward-facing side of the tabs.

Tools



T30 Torx Driver

Step 2 526.76 579.61

Hardware

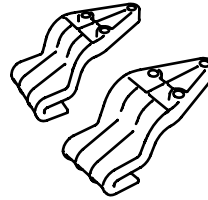

Stiffener Clips  
Part #595.14 - Right  
Part #595.15 - Left  
Qty. 1 of each

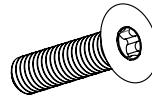

M5 x0.8x22  
Flanged Torx Screw  
Part #579.61  
Qty. 6



M5 Flat Washer  
#565.90  
Qty. 6



M5 Nyloc Nut  
Part #526.76  
Qty. 6

Tools



T30 Torx Driver

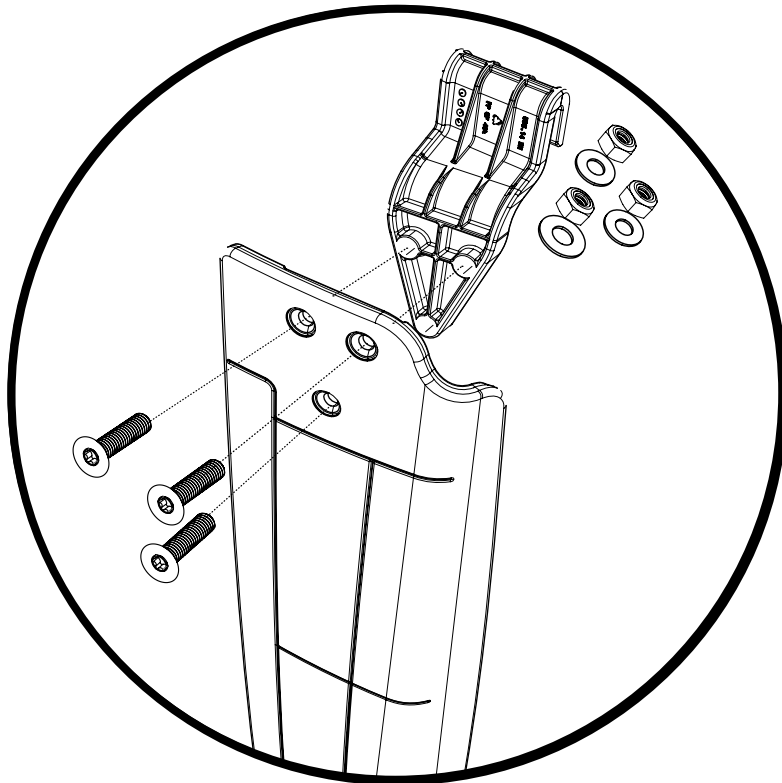

Step 2

Attach the Hook #595.14 (right and #595.15 left) to the bottom (ribbed side) of each side stiffener from each side window assembly #595.48 (right and #595.49 left). Use screw 579.61, Washer 565.90, and Nyloc Nut 526.76 from the hardware kit.

**NOTE:** Make sure you install these parts in the proper orientation, and all LH and RH components match.

Step 1 592.88

Hardware

Step 2

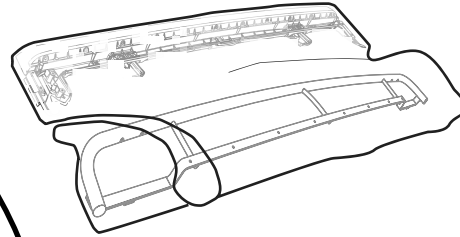

#1 Bow / #5 Bow Fabric Deck  
Part #595.50  
Qty. 1

Tools



T20 Torx Driver

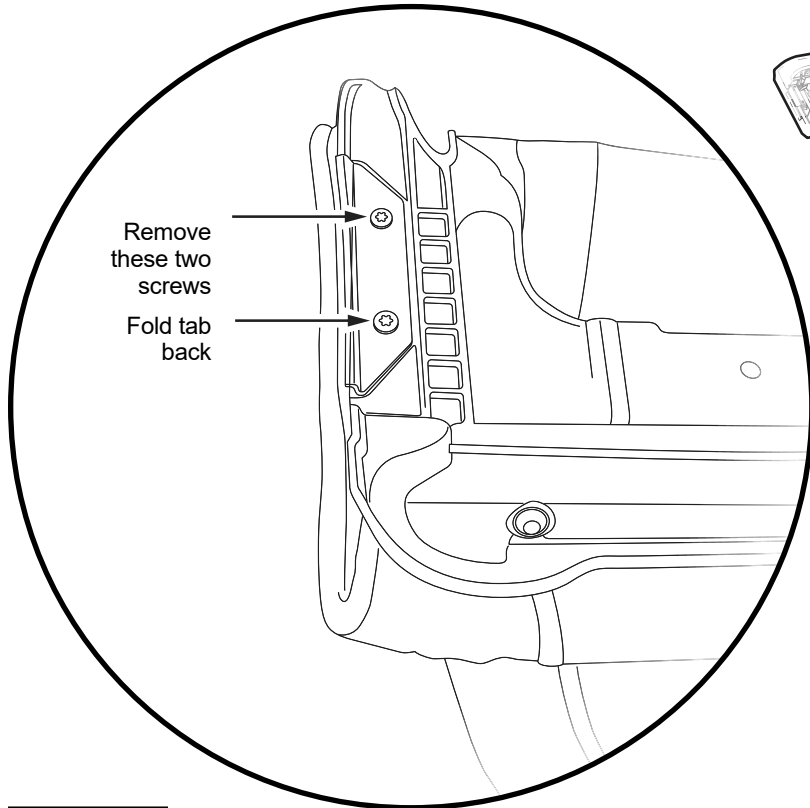

Remove these two screws  
Fold tab back

Step 1

On the underside of the #1 Bow-Fabric Deck, remove the two screws on each side that hold down the tabs, and fold each tab back.

Repeat on both sides of the #1 Bow before you place this fabric assembly on top of the vehicle.

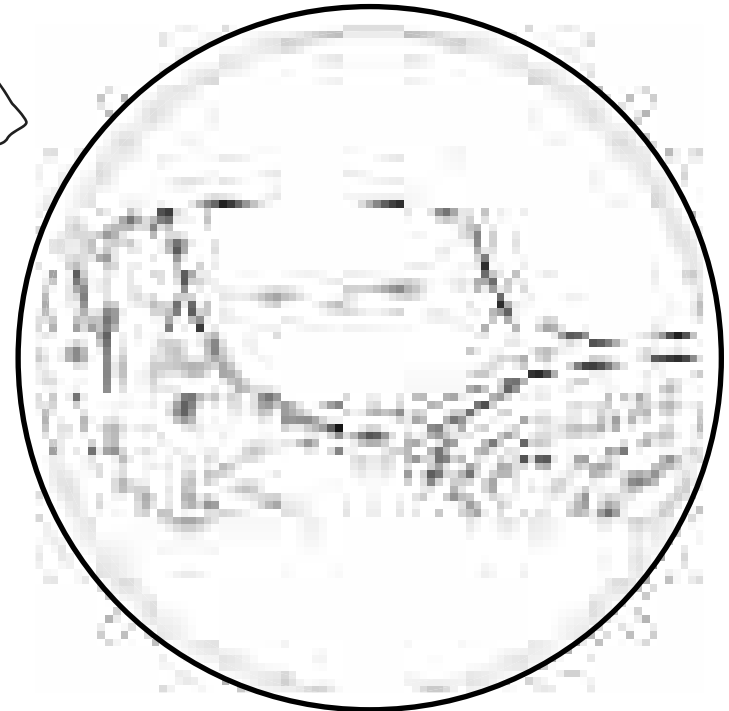

Step 2

Place the #1 Bow/ #5 Bow-Fabric Deck #595.50 on top of the windshield header in position.

Carefully lay the top fabric across the Jeep hood, with the underside facing up.

**WARNING:** Take care to protect you vehicle

form the metal and fabric assembly - DO NOT

PLACE DIRECTLY ON PAINTED BODY PANELS -

Step 3	595.02	595.03	572.83
--------	--------	--------	--------

**Hardware**



Side Bow Assembly  
 Part #595.02 - Right  
 Part #595.03 - Left  
 Qty. 1 of each

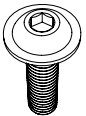

M6 x 1.0 x 10mm  
 Flanged Allen Screw  
 Part #572.83  
 Qty. 4

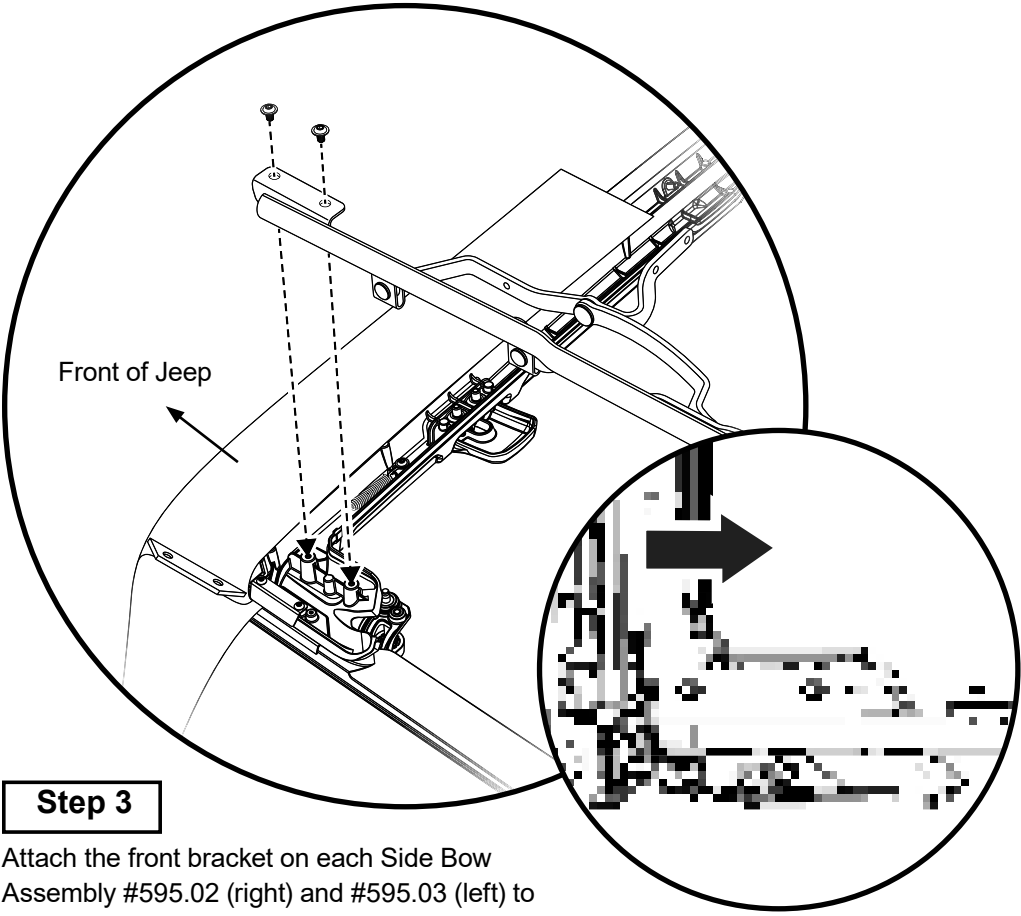

**Step 3**

Attach the front bracket on each Side Bow Assembly #595.02 (right) and #595.03 (left) to the #1 Bow-Fabric Deck.

With the Fabric Deck flipped over the Jeep hood, use two (2) #572.83 M6 x 1.0 x 10 Flanged Button Head Screws on each side to attach the welded bracket to the #1 Bow.

**NOTE:** Very Important:

You must push the #1 Bow-Fabric Deck as far REARWARD as possible to allow inserting the screws to attach the Side Bows.

**Tools**

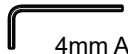

4mm Allen Wrench

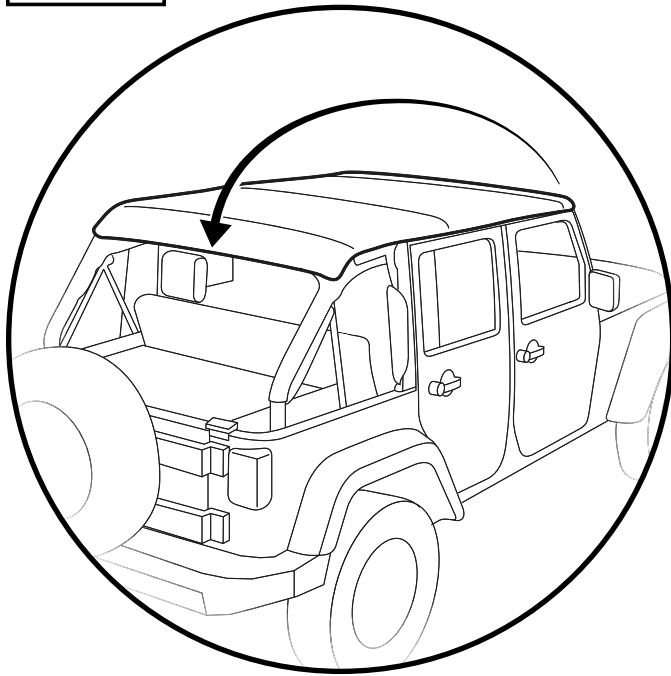
**Step 1****Tools**

T20 Torx Driver

**Step 2**

393.79

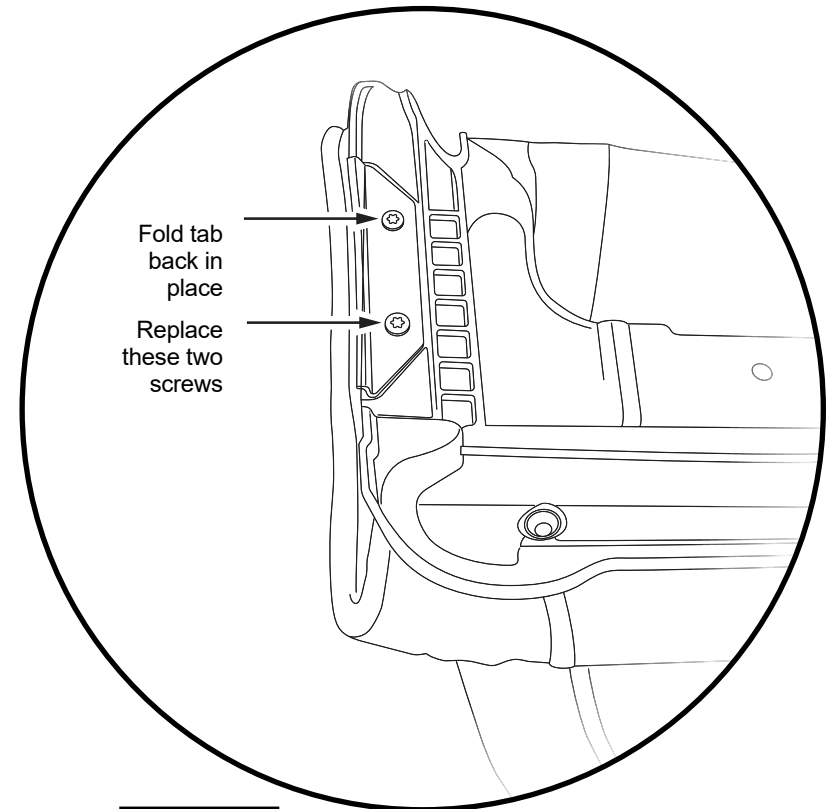
**Step 1**

Pull the Top Fabric back across the top of the Jeep and all the installed Bows

Lift the front of the #1 Bow/Header and fabric to about to either point up to the sky, or fold fully back to the open SUNRIDER position.

**Step 2**

Re-attach the tabs to the underside of the #1 Bow-Fabric Deck using the two (2) screws on each side that you removed in pervious steps.



**Step 3**

573.20

573.21

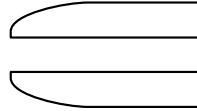
**Hardware**

Foam Seals  
Part #573.20 (right)  
Part #573.21 (left)  
Qty. 1 of each

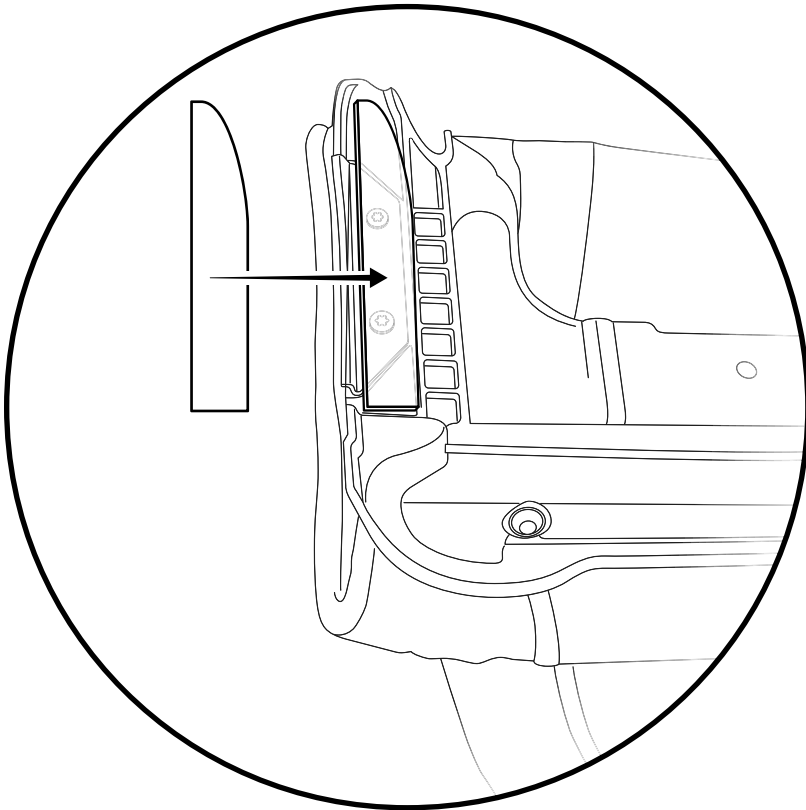
**Step 3**

With the front portion of the top folded back, locate the two (2) Foam Seals #573.20 and #573.21.

Remove the protective liner from the back side of each Foam Seal and place the Foam Seal in the location shown in the diagram.

Repeat on both sides of the Jeep.

**Step 1** 595.50 533.19

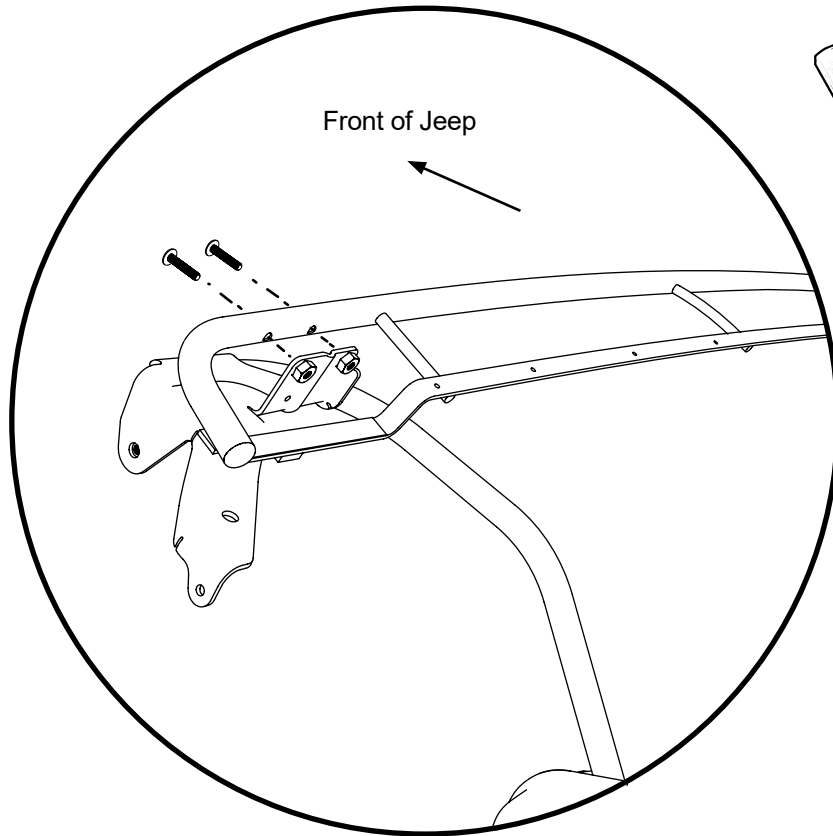

**Step 1**

Attach the #5 Bow #595.50 to the tabs on the Lift Assist Assembly using two (2) M6x1.0x30 Flanged Torx Screw #533.19 per side. (shown without the attached fabric deck)

**Hardware**

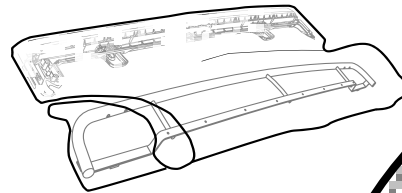

#1 Bow / #5 Bow Fabric Deck  
Part #595.50  
Qty. 1

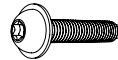

M6x1.0x30  
Flanged Torx Screw  
Part #533.19  
Qty. 4



Plastic Push Pin  
Part #533.96  
Qty. 2

**Tools**



T30 Torx Driver

**Step 2** 533.96

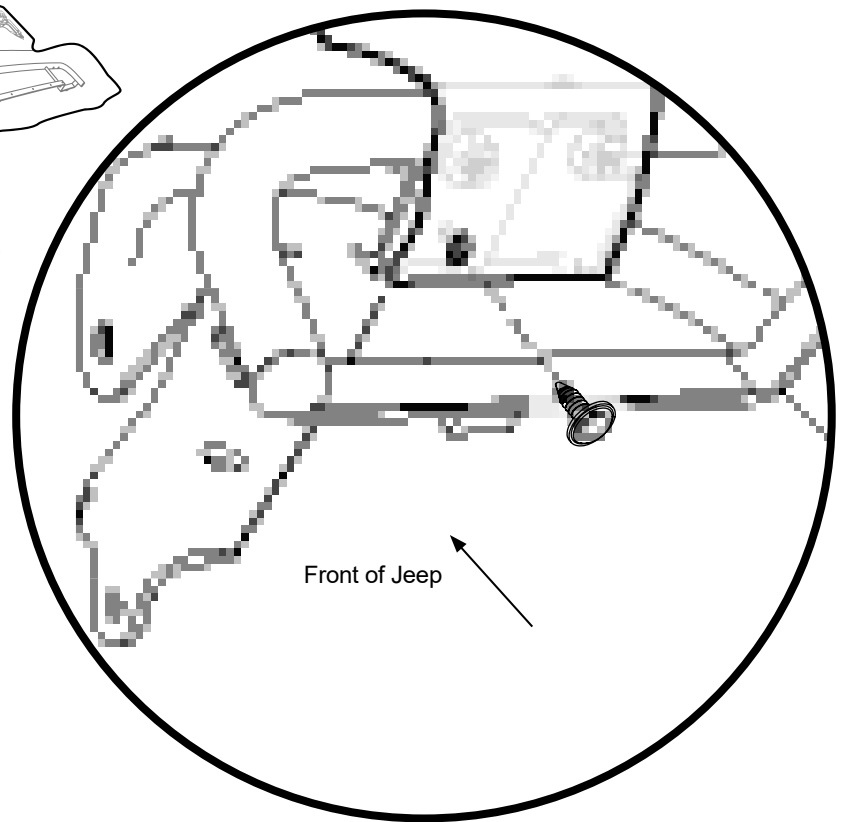

**Step 2**

Secure the inboard (toward center of vehicle) Fabric Flap (attached to the underside of the top fabric) to the rear facing side of the bracket of the #5 Bow, using one (1) plastic push pin #533.96 for each side.

Lift Up the fabric for easier attachment. Placing the pin into the pre-punched holes in the Flap may make attachment to the #5 Bow bracket easier.

Step 3 393.79

Hardware

Step 4 599.01

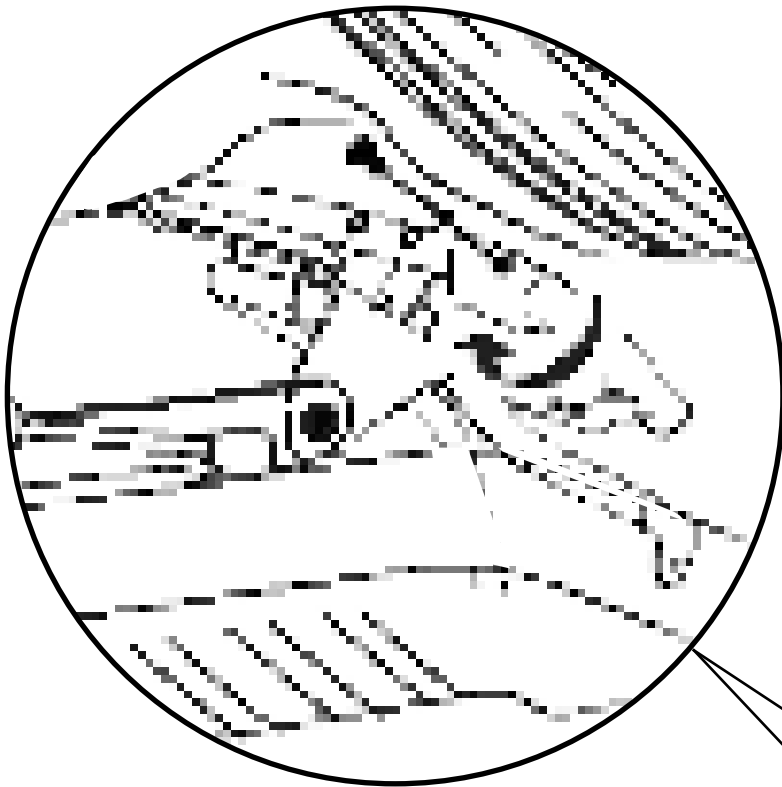

 Screw-Binding Barrel  
Part #599.01  
Qty. 2

 Sheet Metal Screw  
Part #393.79  
Qty. 2

Tools

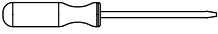
 Flat Blade Screwdriver

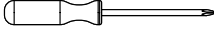
 Phillips Screwdriver

 **GLUE**  
Super Glue

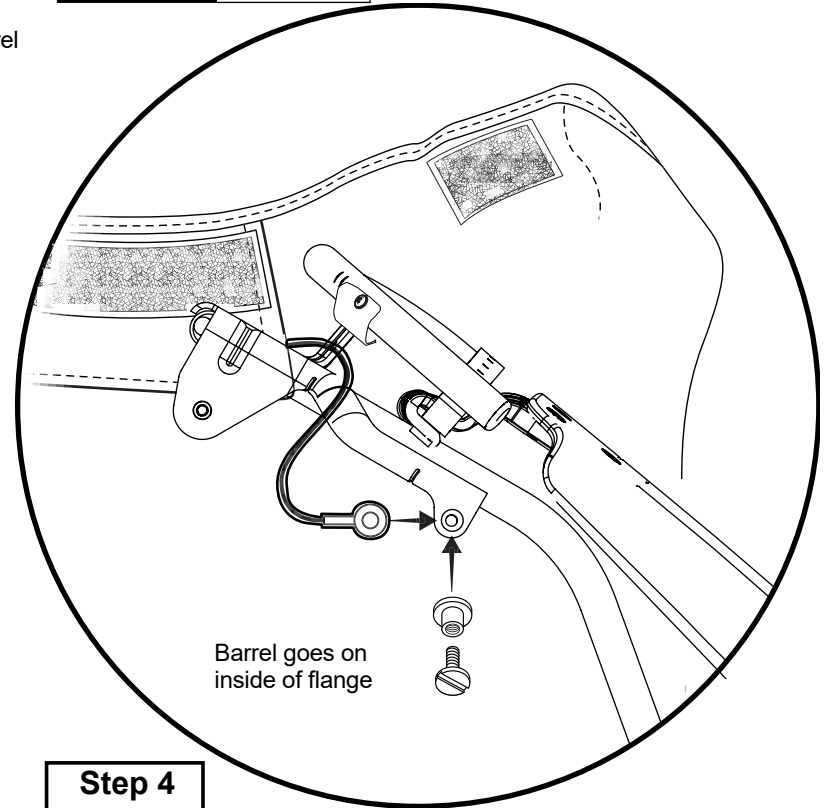

Step 4

Locate the Cable where it exits the underside of the top near the #5 Bow on each side.

To attach the end of each cable to the #5 Bow Plate / Lift Assist bracket;

Secure the end of the cable to the hole in the lower corner of the #5 Bow assembly with the #599.01 screw with Binding Barrel.

**NOTE:** The Barrel goes on the inside of the #5 Bow flange, that is connected to the Lift Assiste Mechanism, and will protude to the outside. Apply a small drop of SuperGlue as a thread-locker. Next, loop the eyelet on the end of the cable over the Barrell on the outside of the #5 Bow flange, getting captured underneath the screw head, as you screw it into the Barrel.

Step 3

Locate the outboard (toward exterior of vehicle) Fabric Flap. Wrap the flap under the #5bow, and then attached to front facing pre-drilled hole at the top of #5 Bow, using one (1) Screw #393.79 for each side.

Lift Up the fabric for easier attachment. Placing the Screw into the pre-punched holes in the Flap may make attachment to the #5 Bow easier.

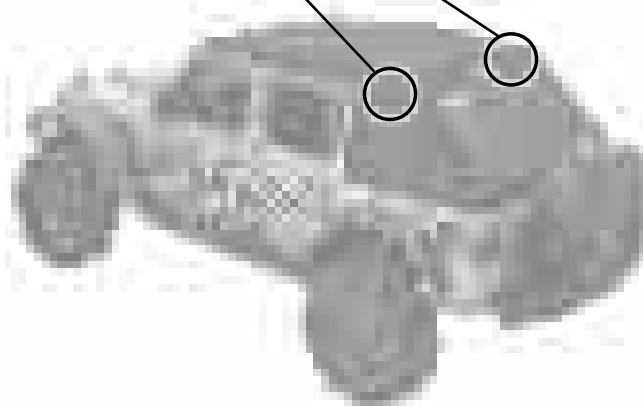

Step 1

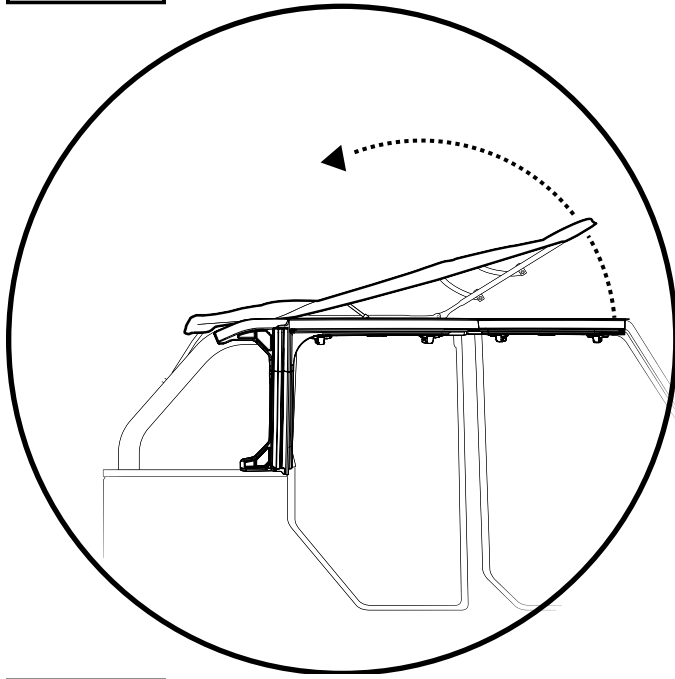

Step 2

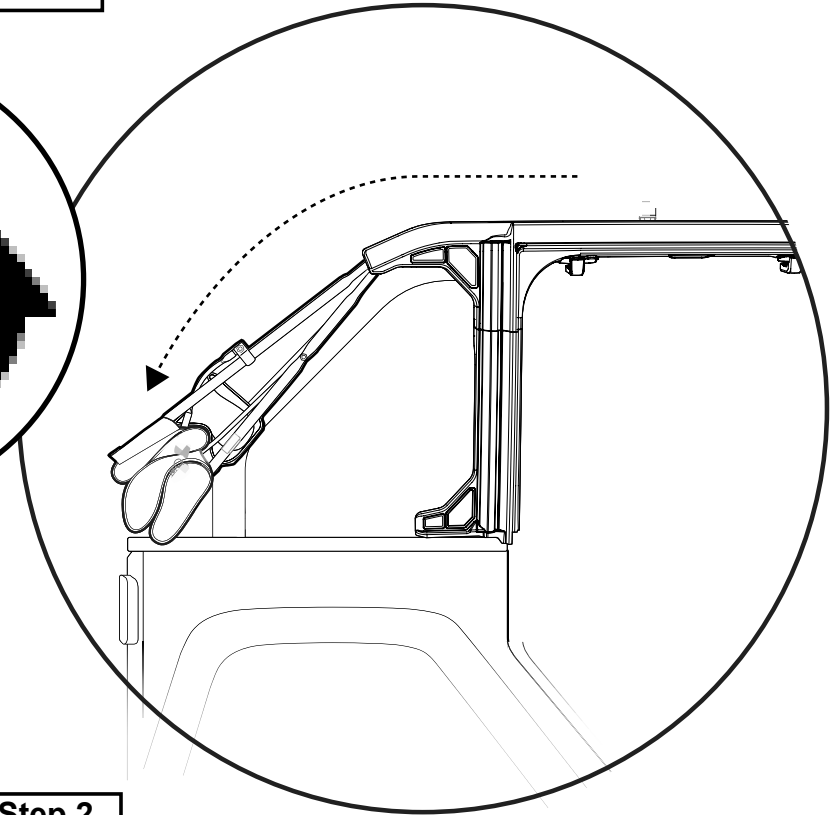
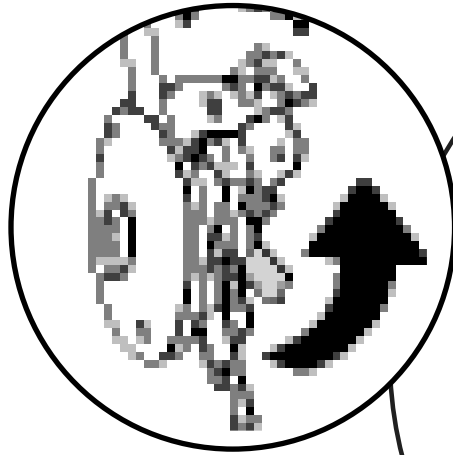

Step 1

Fold the top to the rear, and rest the top down in the body tub.

Step 2

Roll the Soft top assembly down on the Guide-Tracks down to rest the rear of the cargo area.

**NOTE:** You need to release the Lift Assist lock mechanism. To Unlock: Lift the yellow levers up, and then reach and pull the #5 Bow back and Down-stack the top assembly.

Downstack the Soft top deck.

- ① Open the Cockpit Sunrider;
- ② Unlock the Lift-Assist Mechanism;
- ③ Roll Down the assembly to the Down-Stack position, so you can tighten the nuts in the next step.

## Step 3

## Tools

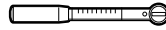

Torque Wrench

**WARNING:** Tighten  
the M6 Flanged Nuts  
#591.47 to 7ft-lbs.

- DO NOT  
OVERTIGHTEN -

## Step 3

Now you can tighten the three (3) nuts  
that secure each Lift Assist mechanism  
to the sport bar.

Use of a torque wrench to tighten the  
nuts to 7 ft-lbs is recommended.  
Due to limited access space, multiple  
tools may be required, but do not exceed  
7 ft-lb torque.

**WARNING:** Tighten the M6 Flanged Nuts #591.47 to  
7ft-lbs. - DO NOT OVERTIGHTEN -

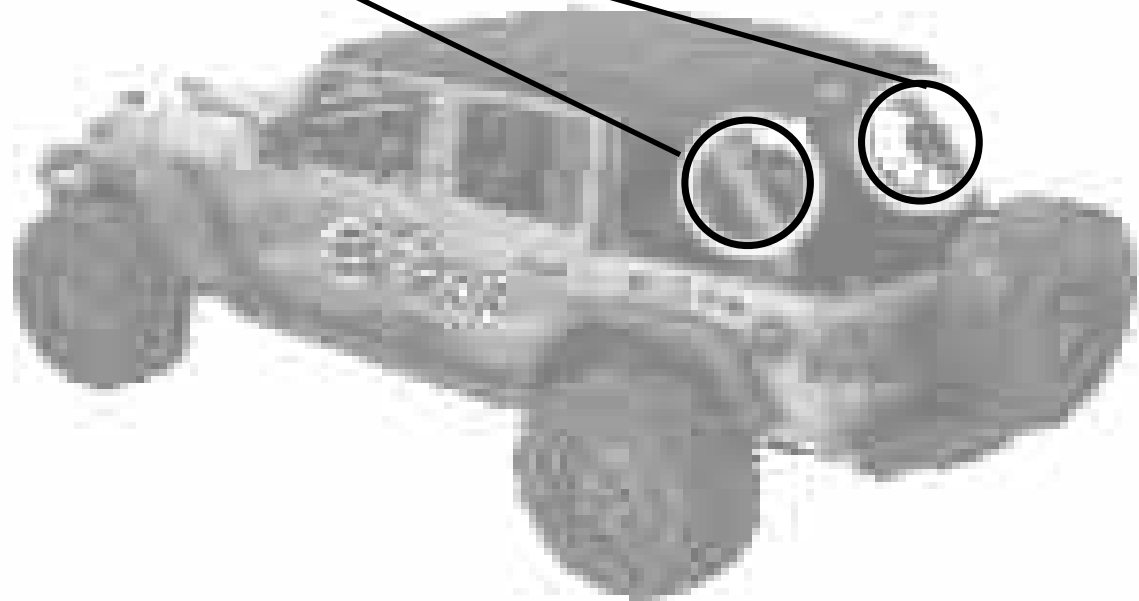

**Step 1**

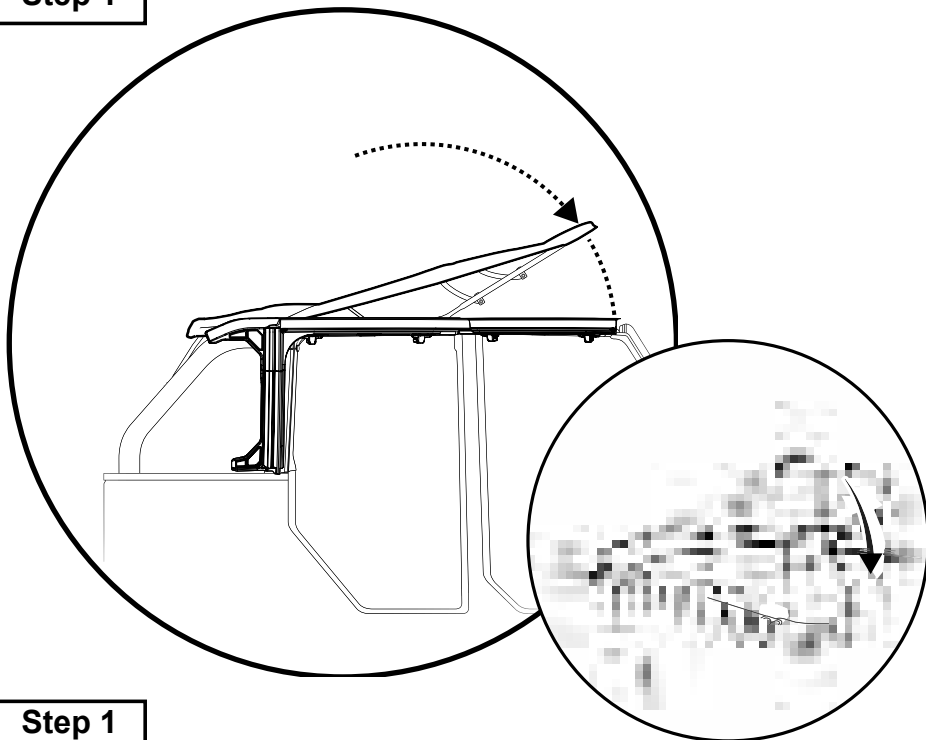

**Step 1**

Fold the top forward to close it.

**Step 2**

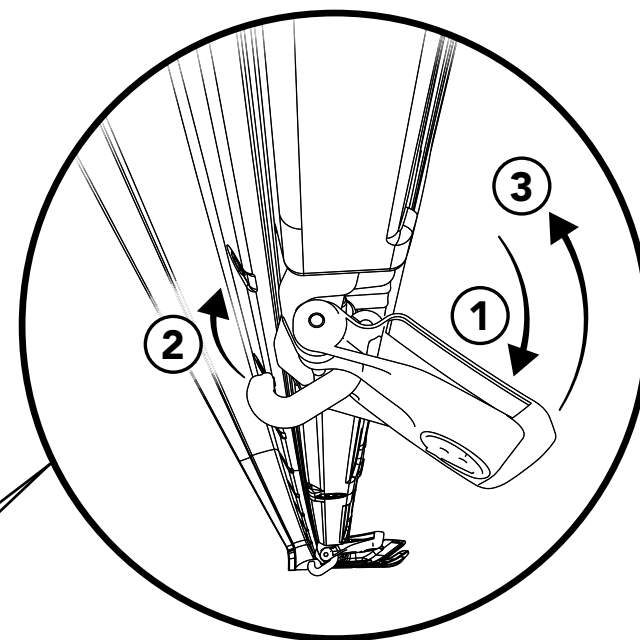

**Step 2**

Fold the Sunrider closed and secure both latches to the vehicle's windshield header.

- ① Pivot the latch handle down;
- ② Engage the hook;
- ③ Pivot the latch handle back up.

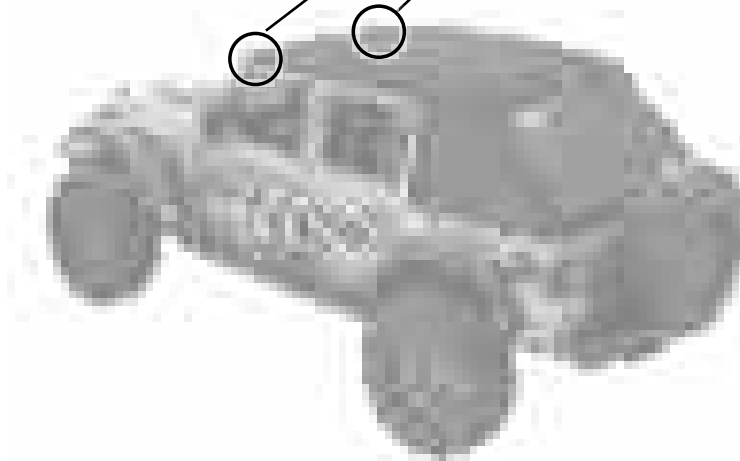

**Step 1**

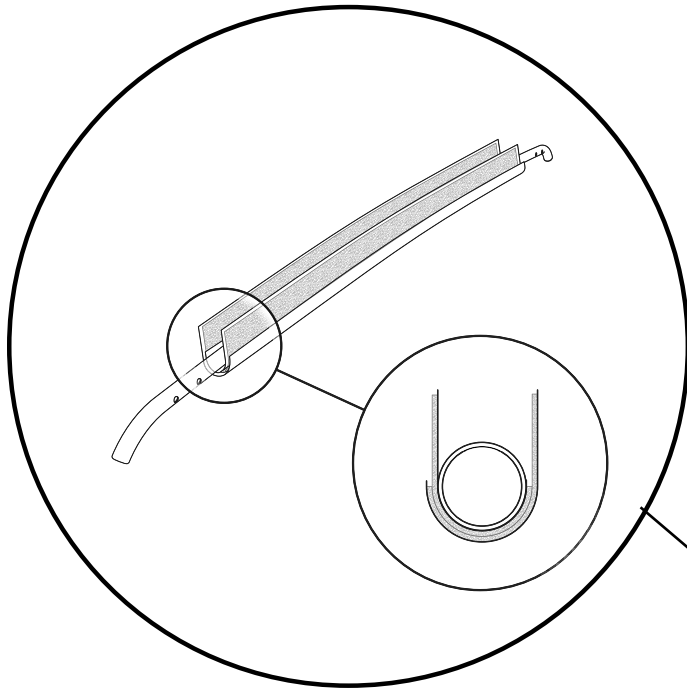

**Step 1**

Locate the fabric flap sewn to the inside of the fabric top, just above the #4 Bow.

Wrap these flaps around the #4 Bows so that the Hook side of one flap attaches to the Loop side of the other flap.

**Repeat this step, wrapping #4 Bow, #3 Bow and #2 Bow in this way.**

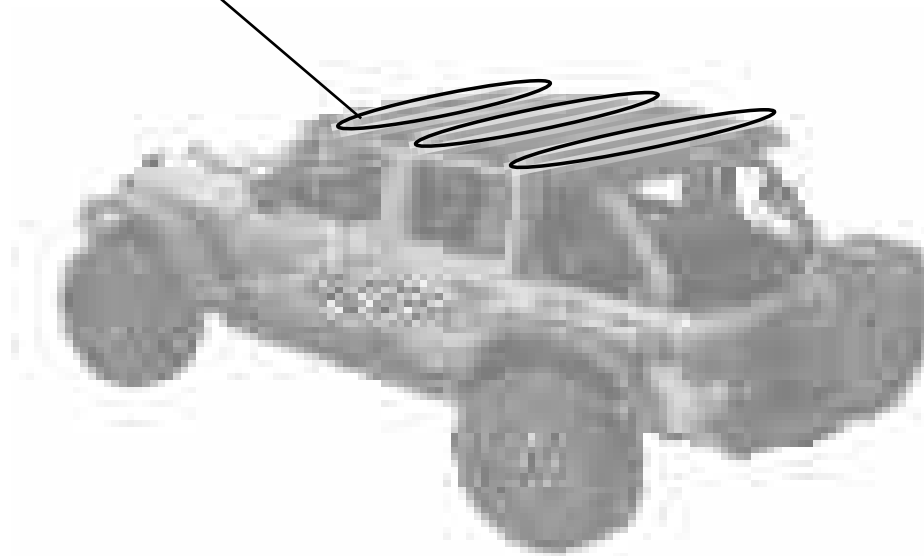

**Step 1**

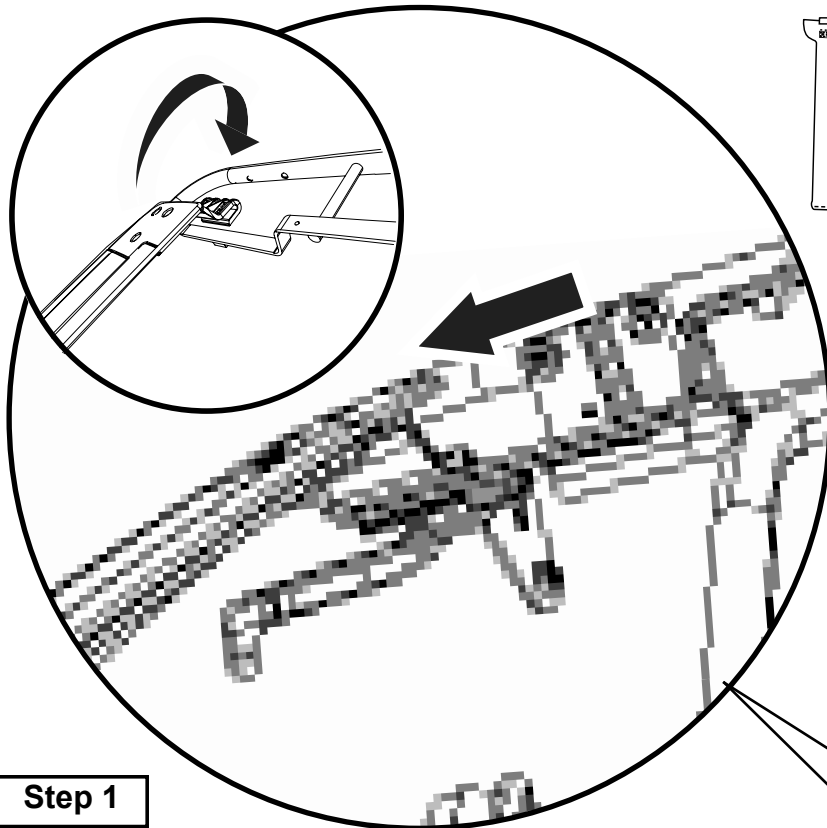

**Hardware**

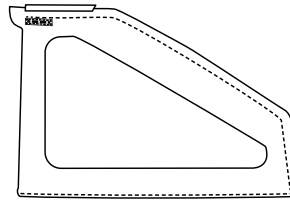

Quarter Windows  
Left and Right  
Qty. 1 of each

**Step 2**

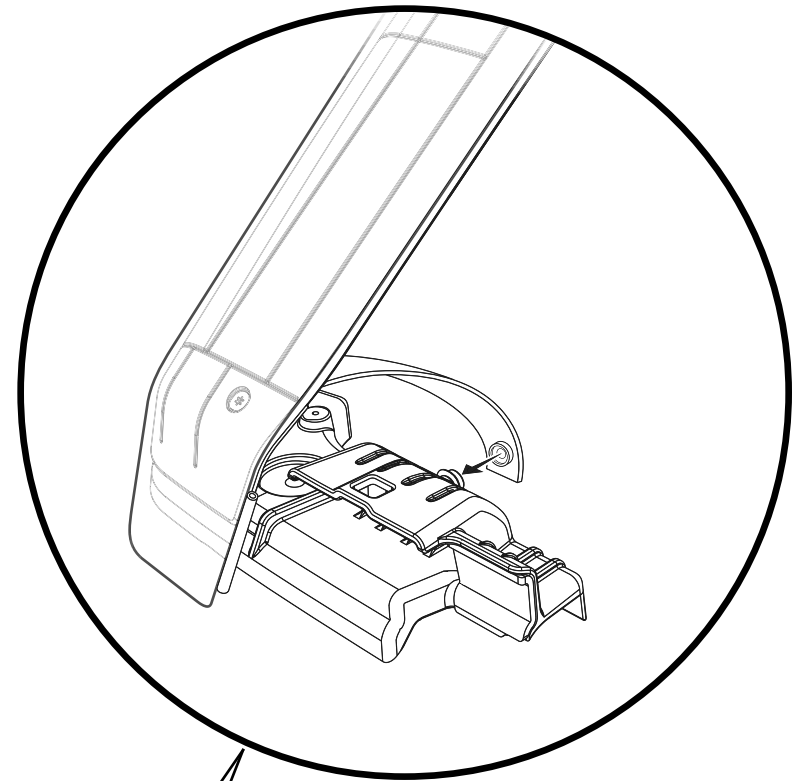

**Step 1**

Locate the Hook on the inside of the rear top corner of the left Quarter Window Stiffener.

Place the hook on the Quarter Window onto the #5 Bow. Stay to the outboard side of the spacer block.

Repeat this step on the right side Quarter Window.

**Step 2**

Secure the Quarter Panel Stiffeners to the Tailgate Retainers.

Locate the strap attached to the inside of each Stiffener. Snap the loose end of this strap to the snap located on the inside of each Tailgate Retainer.

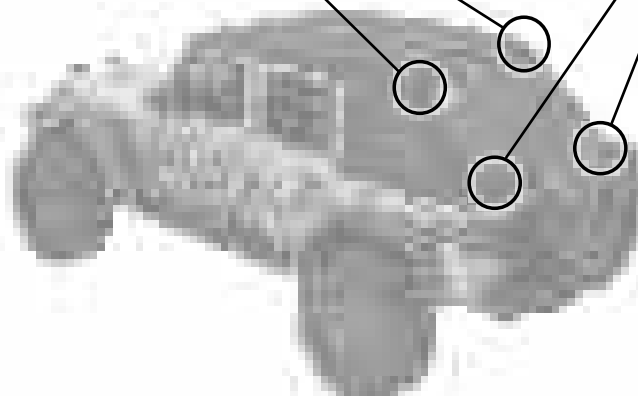



## Step 3

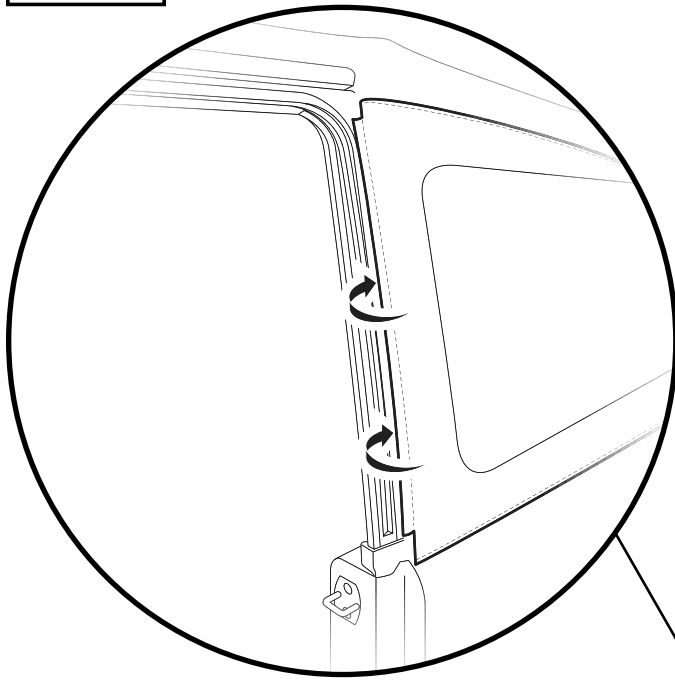

## Step 3

Locate the sewn-in plastic strip along the front edge of the left Quarter Window.

Tuck this plastic strip into the vertical channel along the outside face of the left Rear Door Rail.

Repeat on the right side of the Jeep.

## Step 4

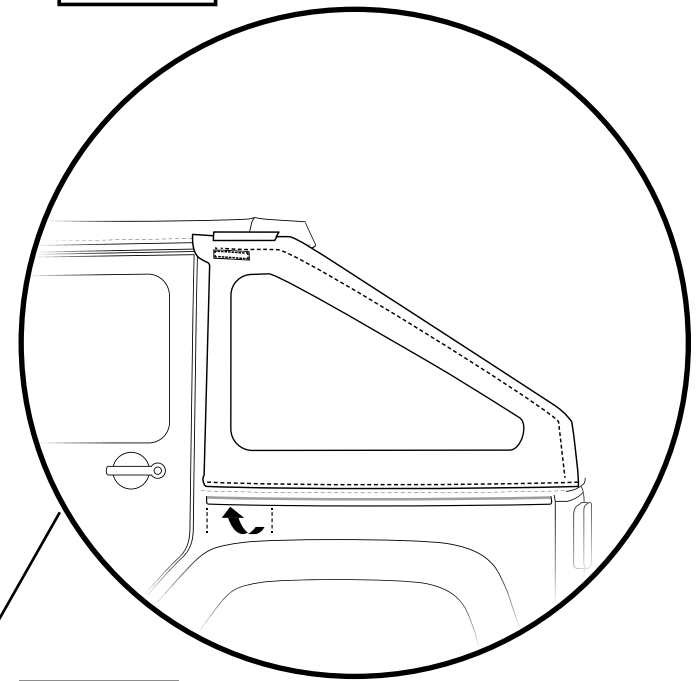

## Step 4

Tuck just the first couple of inches of the plastic strip  
- along the bottom edge of the left Quarter Window - under the Jeep belt rail, by rolling it up underneath the belt rail.

Repeat on the right Quarter Window.

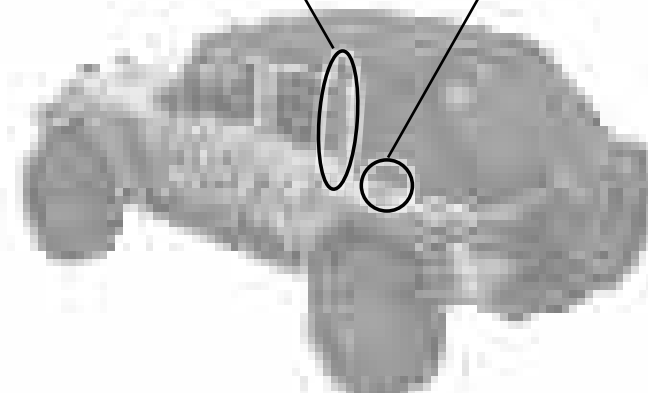

Step 5

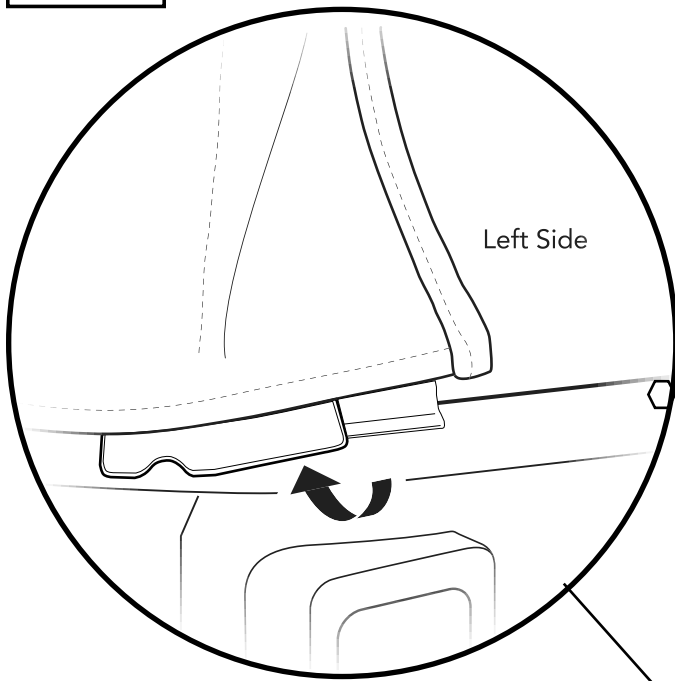

Step 5

Tuck the plastic tab at the bottom rear corner of each Quarter Window under the Jeep belt rail.

Roll the tab on each side up underneath the Jeep belt rail.

Step 6

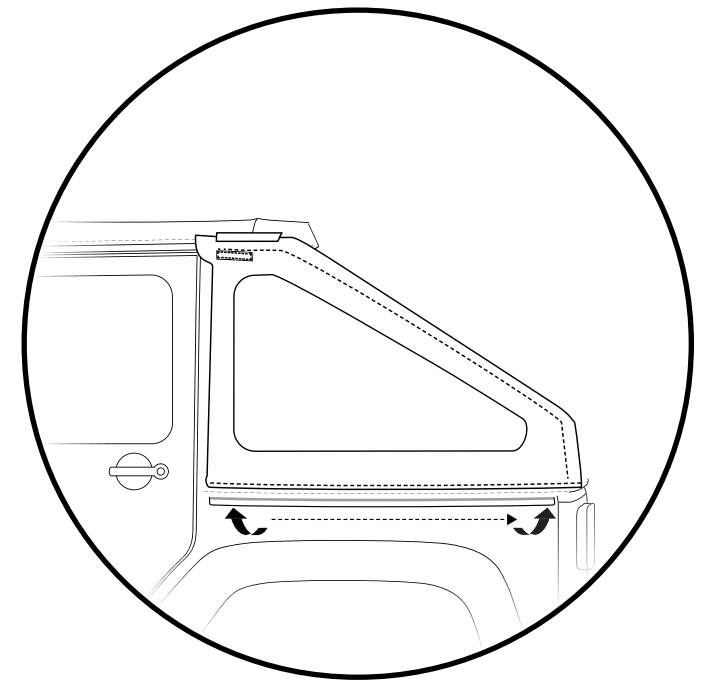

Step 6

Secure the bottom edge of each Quarter Window.

Tuck the plastic flap along the bottom edge of each window under the Jeep belt rail along the entire length of the flap, from front to back.

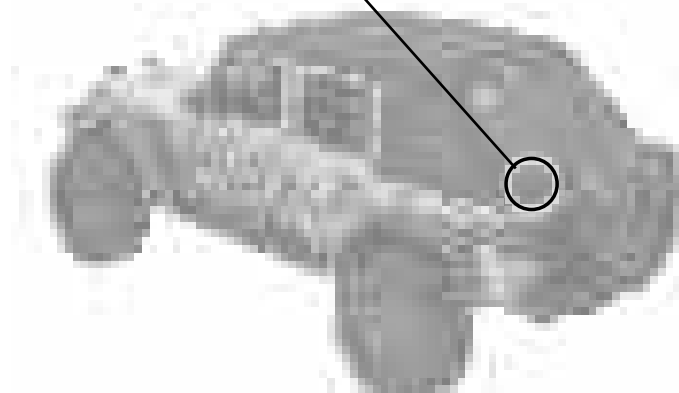

## Step 1

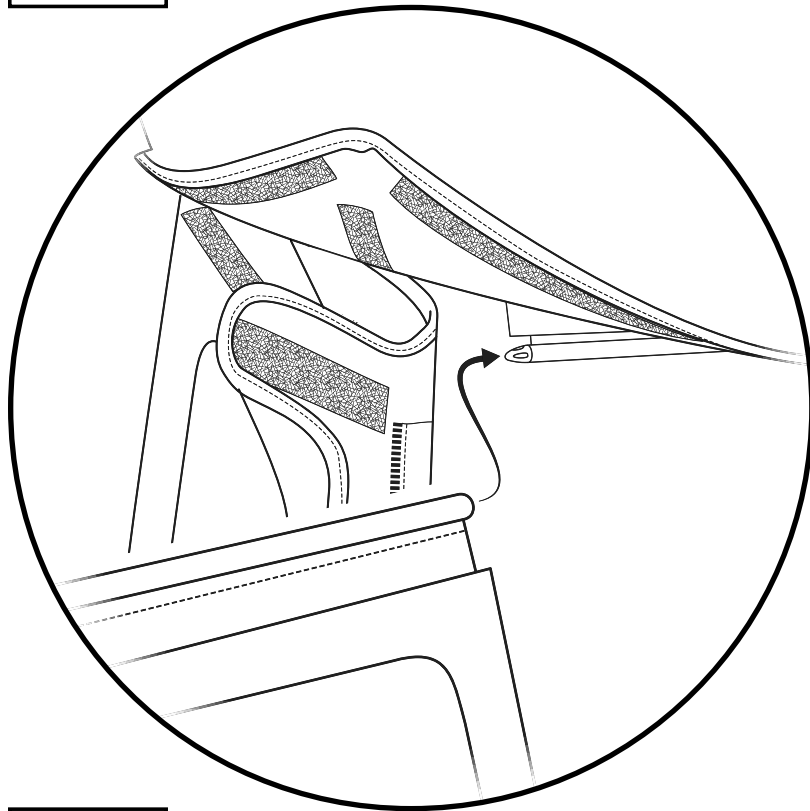

## Step 1

Lift up the rear corners of the Top Fabric to expose the Rear Window attachment tube.

Slide the hollow tip of the sewn-in plastic tube at the top right corner of the Rear Window over the left-side tapered tip of the rail sewn onto the bottom edge of the top fabric, and slide the Rear Window to the right until it meets the right side Quarter Panel Stiffener.

## Hardware

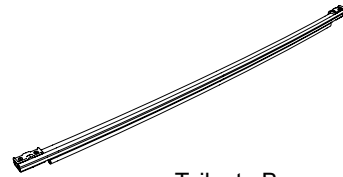
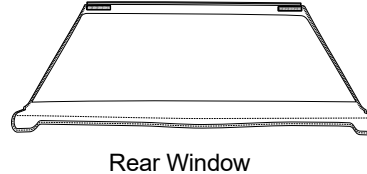

## Step 2

575.33

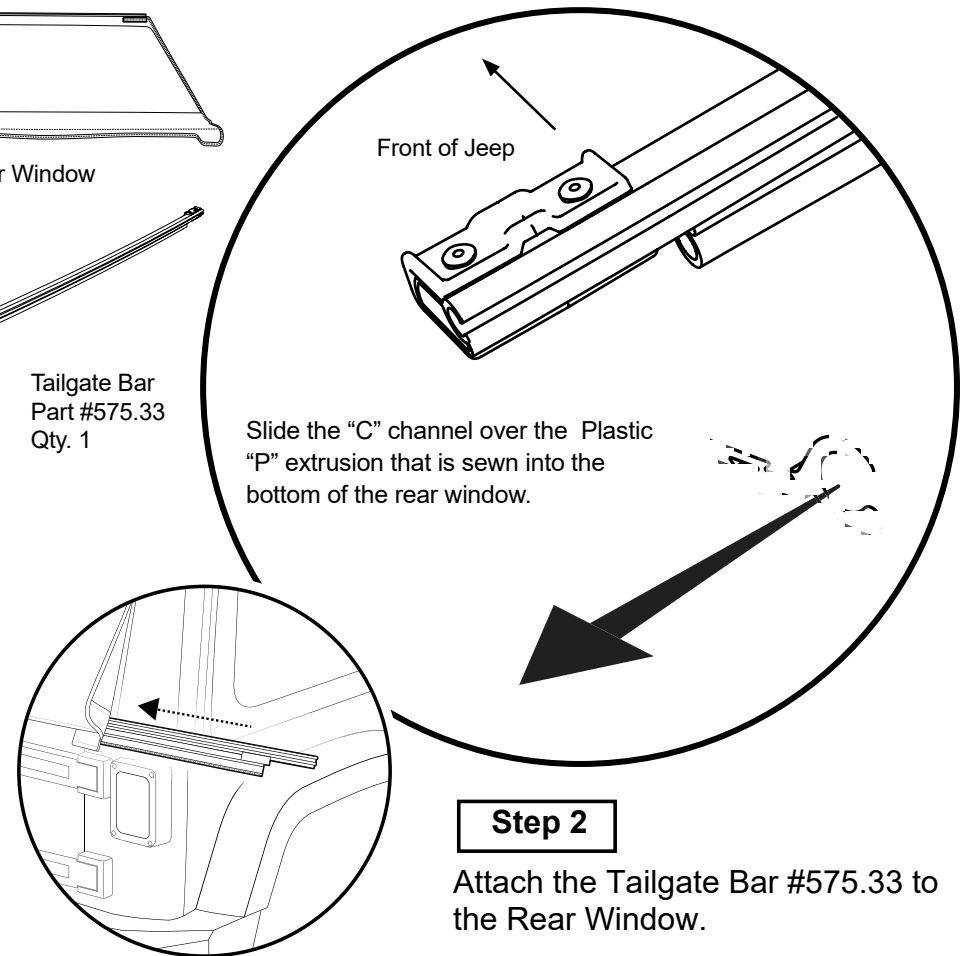

## Step 2

Attach the Tailgate Bar #575.33 to the Rear Window.

Slide the Tailgate Bar "C" channel onto the Plastic "P" component that is sewn into the bottom of the window.

**Step 3**

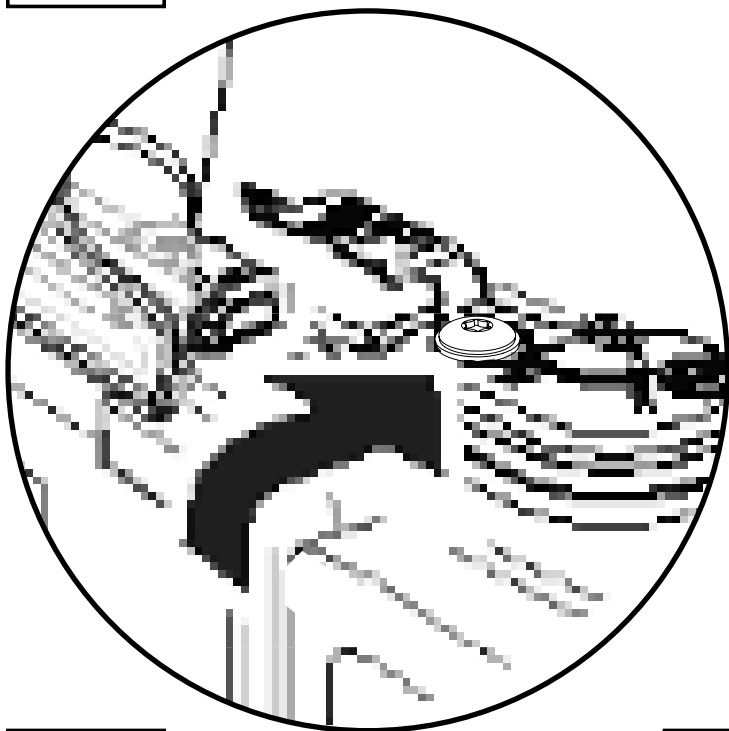

**Step 3**

Snap the front edge of the Tailgate Bar into the channel on each Tailgate Bar Retainer. (Shown without corner window assembly for clarity)

Repeat for both sides of the tailgate.

**Step 4**

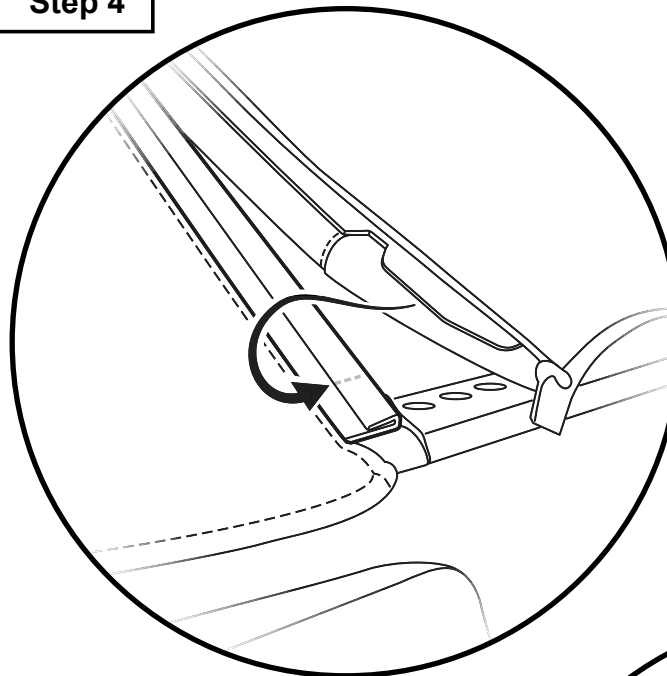

**Step 4**

Locate the plastic channel along the rear inside edge of each Quarter Window.

Roll the sewn-in plastic tab on the outside edge of the Rear Window into the open side of the channel, starting either at the top and working down, or at the bottom and working up.

Left side shown above.

**Step 5**

Tuck the plastic tab at the bottom right corner of the Rear Window under the Jeep belt rail, by rolling it up underneath the belt rail.

Repeat for the left side.

**Step 5**

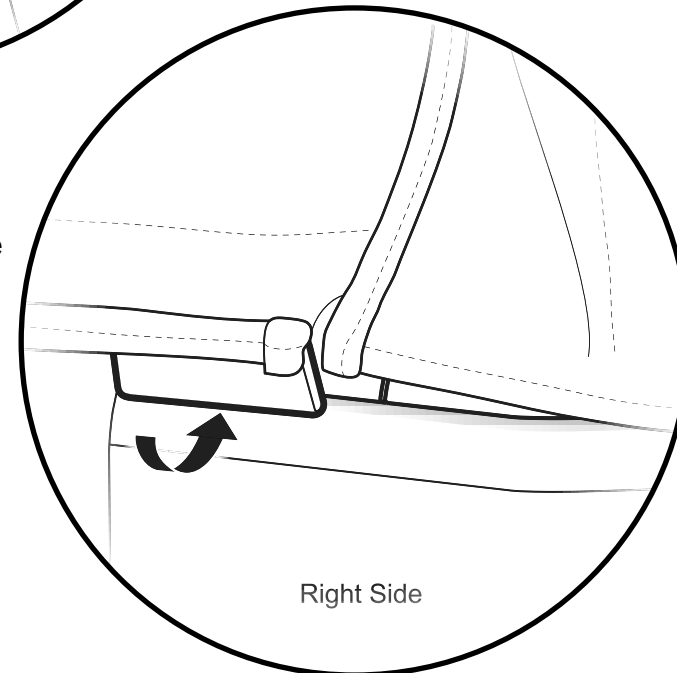

Right Side

## Step 1

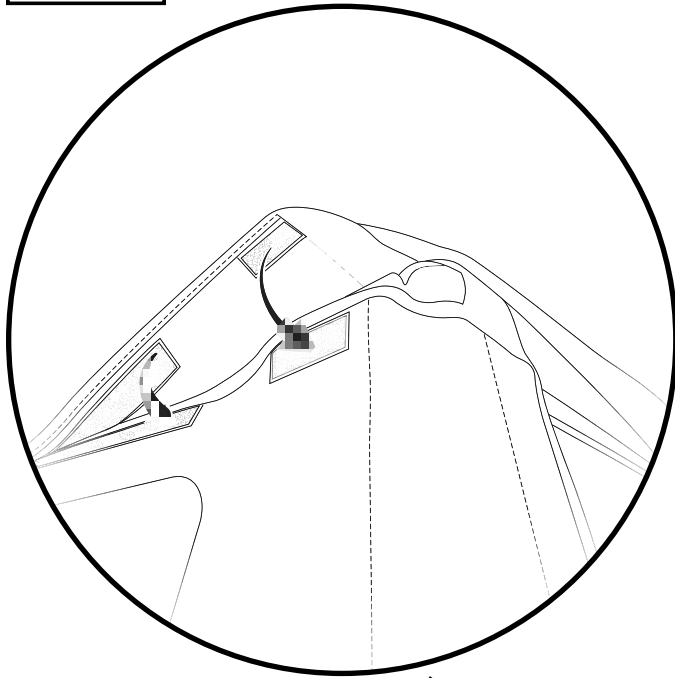

## Step 1

Locate the Hook & Loop strips at the underside of each rear corner and along the rear quarter window overlap of the top fabric.

Snug the rear corners of the top by attaching the Hook & Loop strips on the underside of the top fabric to the strips along the top edges of the Quarter Window and corners.

## Step 2

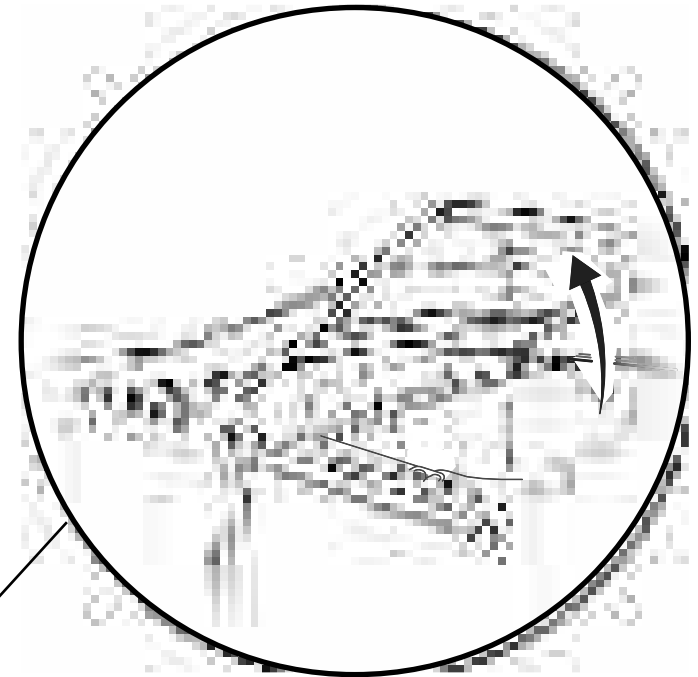

## Step 2

Once the full installation is complete, release the header latches and put the top into the Sunrider mode, to allow the top to stretch and normalize for a while before removing windows or folding the top down.

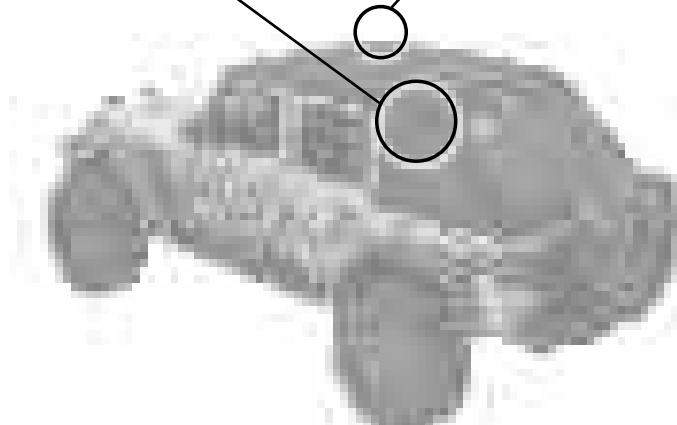



## Warranty Information JL Trektop Ultra

Vehicle Application:  
Jeep® JLU Wrangler Unlimited 2018 - Current  
Part Number 54925

### WHAT BESTOP WARRANTS

Subject to the terms and conditions of sale, including any terms and conditions set forth by Bestop, Inc. (“Bestop” or “us” or “we”) in our then-current terms of sale on our website (collectively, the “Terms”), Bestop represents and warrants that: the covered products listed in the “Covered Products and Warranty Periods” section (a “Product”) will substantially be free from defects in materials and workmanship for the specified warranty periods set forth in that section.

### THE WARRANTY IS LIMITED AND CONDITIONAL

This warranty applies to the original purchaser of the Product only. The warranty is valid only as long as the original retail purchaser owns the vehicle upon which the Product is installed. The warranty expires should the Product be removed from the original vehicle or if the original vehicle is transferred to another owner.

This warranty is not transferable or assignable. The warranty does not apply to Product bought from auction-style or price-bid websites.

THE LIMITED WARRANTY AND STATED REMEDIES ARE SOLE AND EXCLUSIVE AND IN LIEU OF ALL OTHER WARRANTIES AND REMEDIES, AND COMPANY EXPRESSLY DISCLAIMS ALL IMPLIED OR STATUTORY OR OTHER WARRANTIES, INCLUDING WITHOUT LIMITATIONS WARRANTIES OF MERCHANTABILITY, NON-INFRINGEMENT OR FITNESS FOR A PARTICULAR PURPOSE. IN NO EVENT WILL COMPANY BE LIABLE FOR ANY SPECIAL, INCIDENTAL, CONSEQUENTIAL, PUNITIVE, INDIRECT OR EXEMPLARY DAMAGES OF ANY KIND, INCLUDING LOST PROFITS OR REVENUE, HOWEVER CAUSED, WHETHER FOR BREACH OR REPUDIATION OF CONTRACT, TORT, BREACH OF WARRANTY, NEGLIGENCE, OR OTHERWISE, WHETHER OR NOT COMPANY WAS ADVISED OF THE POSSIBILITY OF SUCH LOSS OR DAMAGES.

*Some states do not allow exclusion or limitation, so this may not apply to you. This warranty gives you specific legal rights, and you may have other rights which vary from state to state.*

### EXCLUSIONS TO THE WARRANTY

The Limited Warranty excludes, and Bestop is not liable in any way for any warranty claims, damages, or defects related to:

- Misuse, abuse, accidents, vandalism, negligence, fire, or improper installation or modification, or improper or inadequate maintenance;
- Failure to comply with any Product documentation, Bestop instructions, or applicable law or regulations; use in extreme conditions
- Force Majeure including but not limited to, earthquake, hurricane, tornado, flooding, or other disasters natural or man-made, civil unrest, strikes, declared or undeclared war, or lack of performance by, or discontinued product of, supply chain partners whose products, software, operations or management is beyond the control of Bestop;
- Damage resulting in breakage (including without limitation, spontaneous breakage, accidental breakage or breakage by any other means) of a Product or any component part;
- Damage to vinyl windows due to misuse, or cracking due to varying weather conditions.

### YOUR SOLE REMEDY

During the applicable warranty period, Bestop shall, at its option, either repair or replace any Product that it confirms, in its discretion, is non-compliant with the warranties herein. Bestop will not pay for labor charges associated with installation or removal of the Product. Should a specific Product be discontinued, Bestop may, at its option, replace the discontinued Product with a current product or like product.

Please retain your proof of purchase. Original proof of purchase for the Product must accompany any warranty claim. If you have a warranty claim, first you must email Bestop Customer Service at [csbestop@bestop.com](mailto:csbestop@bestop.com) for instructions. All claims must be emailed to [csbestop@bestop.com](mailto:csbestop@bestop.com) within 30 days of discovery of a defective Product, but in no event later than thirty days after the end of the applicable Warranty Period (the “Warranty Notice Period”). Warranty claims made after the Warranty Notice Period are null and void and Bestop shall have no responsibility with respect to such claims.

THIS SECTION SETS FORTH BESTOP’S SOLE OBLIGATION & YOUR SOLE REMEDY WITH RESPECT TO ANY DEFECTS OR OTHER PRODUCT ISSUE. ANY PRODUCTS REPLACED UNDER TERMS OF THIS WARRANTY WILL BE COVERED UNDER TERMS & BALANCE OF THE DURATION OF THE ORIGINAL LIMITED WARRANTY FOR SUCH PRODUCT.



## Warranty Information JL Trektop Ultra

Vehicle Application:  
Jeep® JLU Wrangler Unlimited 2018 - Current  
Part Number 54925

**COVERED PRODUCTS AND WARRANTY PERIODS:** The warranty time periods are as follows for Products manufactured by Bestop:

### **BESTOP® LIMITED LIFETIME WARRANTY**

Trektop® Pro Twill Fabric Top Sunrider® for Hardtop Twill Fabric Top  
Trektop® NX Glide Twill Fabric Top Replace-a-Top™ Twill Fabric Top  
Trektop® NX Twill Fabric Top Supertop® NX Twill Fabric Top  
EZFold™ Soft Tonneaus Floor & Cargo Liners  
ZipRail™ Soft Tonneaus Pet Barriers  
EZRoll™ Soft Tonneaus

### **BESTOP® 5-YEAR LIMITED WARRANTY**

Trektop® NX Glide™ Top (non-Twill) Sunrider® for Hardtop (non-Twill) Replace-a-Top™ Top (non-Twill) Trektop® NX Top (non-Twill)  
Sailcloth Replace-a-Top™ Supertop® NX Top (non-Twill)  
Tigertop™ and Halftop™ Supertop® Classic Soft Top Sunrider® Complete Soft Top Supertop® for Truck  
EZ Fold Hard Tonneau

### **BESTOP® 3-YEAR/100K MILES LIMITED WARRANTY**

Powerboard® & Powerboard® NX  
Trekstep®, Side Mount  
Trekstep®, Rear Mount

### **BESTOP® 3-YEAR LIMITED WARRANTY**

Pavement Ends Sprint Top

### **BESTOP® 2-YEAR LIMITED WARRANTY**

Trektop® Classic Soft Top  
RoughRider™ Soft Storage

### **BESTOP® 1-YEAR LIMITED WARRANTY**

All other Bestop® & Pavement Ends™ products not specified above.

**For further information or request for warranty work, please contact:**

**Bestop Inc. Customer Service**

**Toll-Free: (800)845-3567**

**Main: (303)465-1755**

**E-mail: [csbestop@Bestop.com](mailto:csbestop@Bestop.com)**

**Website: [www.Bestop.com](http://www.Bestop.com)**