



FITTING INSTRUCTIONS

TOYOTA TACOMA (USA)

PRODUCT NUMBER 3423020

WARNING

FOR VEHICLES EQUIPPED WITH SRS AIRBAG
WHEN INSTALLED IN ACCORDANCE WITH THESE INSTRUCTIONS, THE FRONT PROTECTION BAR DOES NOT AFFECT OPERATION OF THE SRS AIRBAG.

TAKE NOTE OF THE FOLLOWING:

- **THIS PRODUCT MUST BE INSTALLED EXACTLY AS PER THESE INSTRUCTIONS USING ONLY THE HARDWARE SUPPLIED.**
- **DO NOT USE THIS PRODUCT FOR ANY VEHICLE MAKE OR MODEL, OTHER THAN THOSE SPECIFIED BY ARB.**
- **DO NOT REMOVE LABELS FROM THIS BULL BAR.**
- **THIS PRODUCT OR ITS FIXING MUST NOT BE MODIFIED IN ANY WAY.**

FITTING KIT NUMBER 6171370

USE	PART No	QTY	DESCRIPTION
IMPACT ABSORBERS TO CHASSIS RAILS	6151096	2	BOLT M12 x 40mm
	6151095	2	BOLT M12 x 1.25 PITCH X 35mm
	4581050	6	WASHER SPRING M12
	4581049	8	WASHER FLAT M12
	6151138	2	NUT ½" UNC
	6151105	2	BOLT ½" x 4 ½" UNC
	3751872L	1	IMPACT ABSORBERS
	3751872R	1	IMPACT ABSORBERS
SPLASH PAN TO BULL BAR	6151021	3	BOLT M8 x 20mm
	4581044	3	WASHER FLAT M8
	3314401	1	SPLASH PAN
	6151132	3	NUT FLANGE
BULL BAR TO IMPACT ABSORBERS	6151045	6	BOLT M10 x 25mm
	4581048	6	WASHER SPRING M10
	4581040	6	WASHER FLAT M10
BUFFERS TO BULL BAR	6151132	4	NUT FLANGE M8
CONTROL BOX BRACKET	6151021	2	BOLT M8 x 20mm
	4581044	2	WASHER FLAT M8
	3751564	1	CONTROL BOX BRACKET
	6151132	2	NUT FLANGE M8
NUMBER PLATE BRACKET	6151017	4	BOLT M6 x 16mm
	6151046	4	WASHER FLAT M6
	6151128	4	NUT FLANGE M6
	3751542	1	NUMBER PLATE BRACKET
BUFFERS AND INDICATORS	3500200	1	BUFFERS KIT
	3500080	1	ARB INDICATORS
8-9000lb WINCH TO PAN	4581040	4	WASHER FLAT 3/8"x 1"
	180302	6	CABLE TIES

THE FOLLOWING PARTS ARE ONLY FOR 2002 MODEL ONWARD

CHASSIS EXTENSION	3756405	2	BRACET CHASSIS EXTENSION
	6151246	2	BOLT M12 X 1.75 PITCH X 25MM
	4581049	2	WASHER M12
	4581050	2	WASHER SPRING M12
	3756407	1	BRACKET SUMP GUARD SUPPORT ASSY
	5846400	2	PACKER RECTANGULAR
	6151294	3	"U" NUT M8
	6151021	3	BOLT M8 X 20MM
	4581044	3	WASHER M8
	4581046	3	WASHER SPRING M8

TOOLS REQUIRED

1 BASIC TOOL KIT, DRILL, ½" DRILL BIT. ¾" LONG REACH SOCKET. (IF DRIVING LIGHTS ARE TO BE FITTED)

ASSEMBLY SEQUENCE FOR BULL BAR INSTALLATION.



1. Remove bumper bar, tie down rings, and tow hook from the vehicle.
2. Remove the crush cans from the front of the vehicle. (On 2002 models onward, the crush cans are welded to the sump guard support cross member which must be removed)
3. Fit the indicators into bar.
4. Fit number plate bracket to bull bar using 6mm hardware.
5. Fit control box bracket to bull bar using 8mm hardware.
6. Fit buffers to bull bar using M8 flange nuts supplied in buffer kit.

NOTE: DO NOT OVER TIGHTEN.

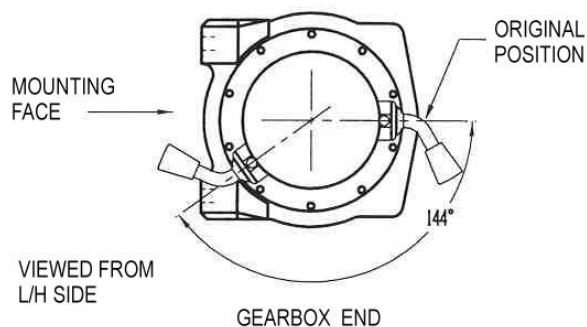

7. To place the clutch handle in the correct position, the winch gearbox must be rotated 144 degrees (4 hole spacings), in anti-clockwise direction when viewed from gearbox end. Place the winch on its end and remove all gearbox bolts. Gently raise the gearbox just enough to rotate it. When the correct position is located, refit all bolts and tighten.

NOTE: Take care not to lift the assembly more than a couple of millimetres while rotating to correct position to avoid unmeshing the gears.

See diagram opposite.



8. Once winch is rotated, position winch on bench face up.
9. Lower bull bar on top of winch and align holes with each other. Using 1 1/4" x 3/8" bolts and flat washers from bolt kit, secure the two most upper holes first and finger tighten. Remove top circlips from vertical rollers of fairlead and remove pins and rollers, this is done so there is easy access to lower bolts.

10. Place roller fairlead in bar cutout over lower holes and fasten using 1 1/2" x 3/8" bolts and 3/8" flat washers supplied in bolt kit.
11. When all is positioned, tighten all bolts firmly and replace rollers, pins and circlips back to roller fairlead.

If fitting the XP 9.5 winch, continue to step 12, otherwise, jump to step 19.



12. If fitting the **XP 9.5 winch**, remove the cover from the control box.

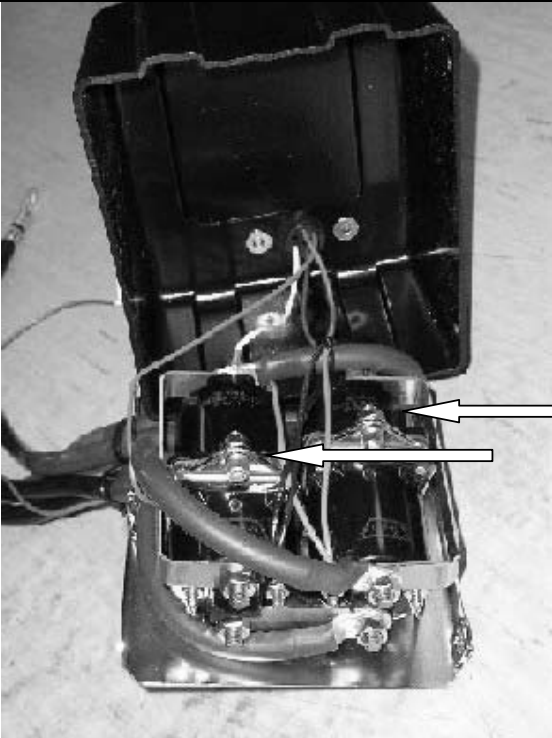

13. Remove the two cap screws, nuts and spacer washers that hold the four solenoids in place.

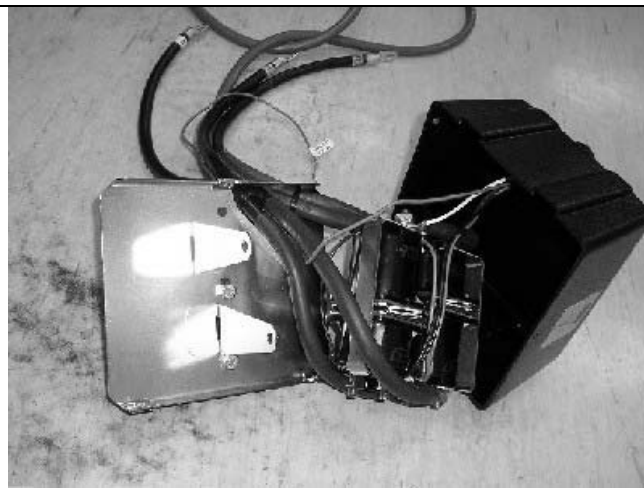

14. Remove the four solenoids from the base of the control box using the copper bus bar as an aid and hold to one side.

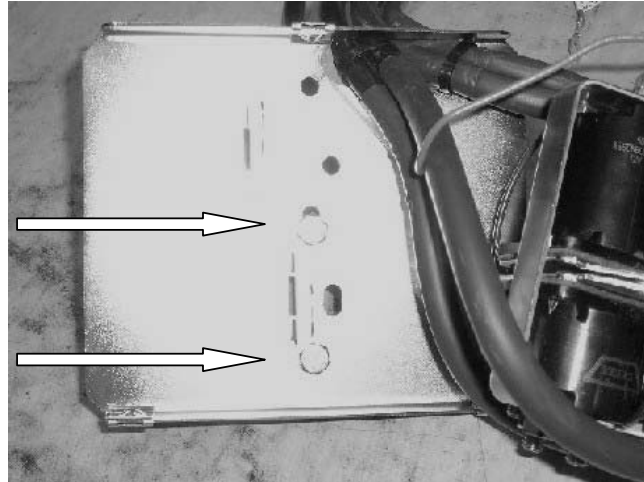

Before

15. Remove the two bolts in the base of the control box and reposition them into the more centralised holes

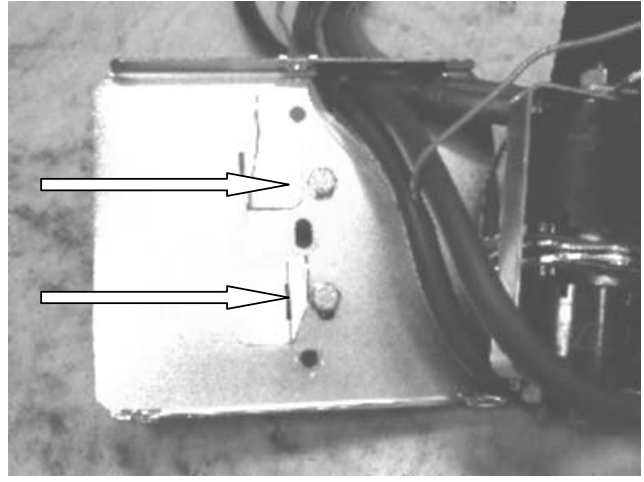

After

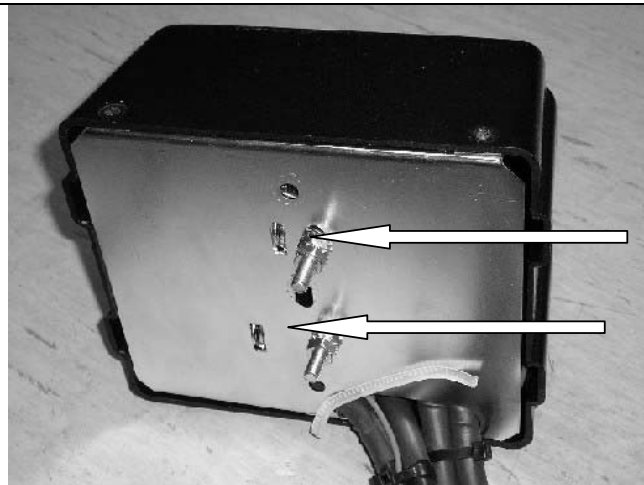

16. Place the 4 solenoids over the 2 metal stands that are facing upwards. Make sure they line up with the holes in the base.



17. Replace the 2 cap screws, washers and nuts removed in step 13 above into original holes.
18. Replace the black cover and refit the three cover screws (DO NOT OVER TIGHTEN)

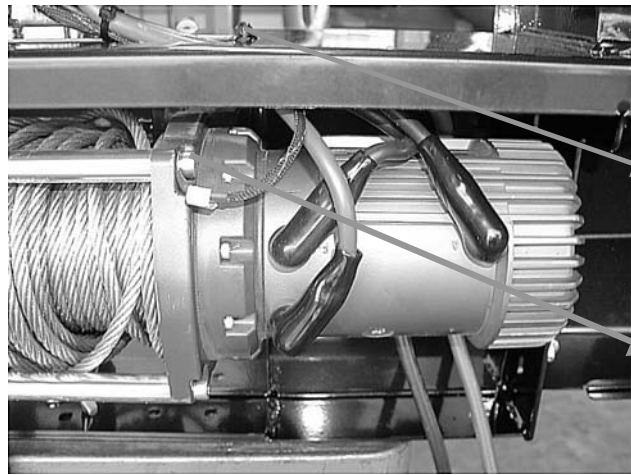

19. Fit control box to control box bracket and tighten firmly.
20. Pull wires through viewer cutout under control box and wire up as per Warn instruction manual.
21. Tie back cables clear of all moving parts with cable tie supplied.
22. Place ground earth lead under bolt of winch tension bar.

FOR 2002 MODELS ONWARD go to step 23.

FOR PREVIOUS MODELS go to step 24. (The parts listed in step 23 will not be required)



23. Push the 3 M8 "U" nuts onto the sump guard support and bolt the chassis extension and support to the front of the chassis using 2 M12 x 35mm fine pitch bolts, flat washers, spring washers and rectangular packer.



24. Fit impact absorbers to both sides of the vehicle.
25. On LHSide of vehicle, refit tow hook using original 12mm bolts.
26. **Prior 2002 models**, fit 12mm x 30mm fine pitch bolt to the front of the chassis.
2002 models on, fit 12mm x 25mm course pitch bolts to the front of the chassis extension.
27. From underneath of bracket, drill right through, using 1/2" drill bit and fit 4 1/2" bolt upward with washers and nut.
28. On RHSide of vehicle under impact absorber, relace tie downs and bolt up using 12mm x 40mm bolts etc.
29. When all bolts are fitted, finger tighten only.



30. Lift bar into position between impact absorbers and bolt up using M10 x 25mm bolts, spring and flat washers. Finger tighten only. (Bolts fit from inside of bar.)

31. At this stage, firmly tighten all impact absorber bolts.

32. Adjust bar so that there is a 20mm gap around the periphery of the vehicle and securely tighten all remaining bolts throughout.

33. Wire main power leads to battery as per Warn instructions and cable tie leads securely from all moving parts with cable ties supplied.

34. Fit number plate to bar using 6mm hardware.

35. Pull winch cable through roller fairlead, and fit tow hook.

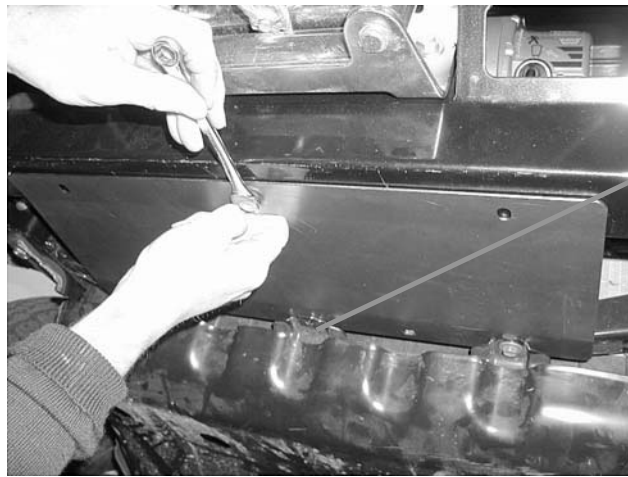

36. Connect the indicator looms to the existing indicator loom with the Scotchloks supplied. Test to ensure the indicators function correctly.

37. **Prior 2002 models.** Once bar is correctly fitted, undo front bolts in splash pan of vehicle, slide bar plate in between and refit bolts and finger tighten.

2002 models on, splash pan is bolted to bull bar as above and bolted to cross member installed in step 23. using 8mm hardware supplied.

38. Using 8mm hardware supplied, bolt plate to front of underside of bar. When all bolts are fitted, tighten firmly.



39. If driving lights are to be fitted, use extension bar with ratchet, $\frac{3}{4}$ " long reach socket to tighten from cutout in centre pan.

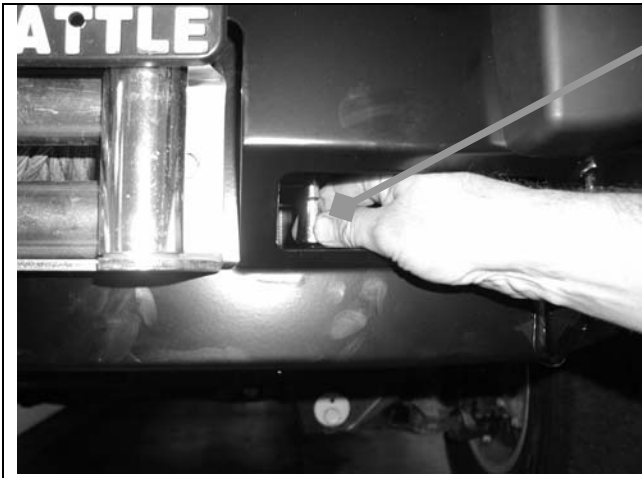

40. Winch handle is operated from this cutout.