









## Assembly Instructions

**Your hardware pack should contain the following:**

CODE	DESCRIPTION	QTY	PICTURE
CB1	Connecting Bolt	24	
CL1	Connecting Lock	24	
AB1	Angle Bracket	4	
SP3	Shelf Peg (lock)	32	
HANDLE2	Bow Handle	2	
S30	Handle Screw	4	
H3	Desk Hinge	2	
35-15S	Screw	12	
C2	Castor Black	4	
C3	Castor Black with Brake	2	
35-17S	Caster Screw	44	
C4	Leg Caster	2	
AXI-HINGE-M	Axi Hinge Male Part	4	

**We advise that you unpack the boxes in the order shown in these instructions and follow the assembly instructions carefully.**

**Please be careful during construction as section of the cupboard may be unstable until construction is complete.**

# STEP 1

You will need to open box -

WINS-SD&CD

Insert CL1 Locks into the holes as indicated with a blue circle



CB1

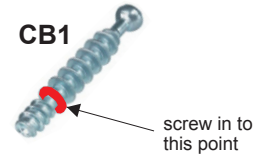

Screw CB1 Bolts into all the holes marked with a red circle

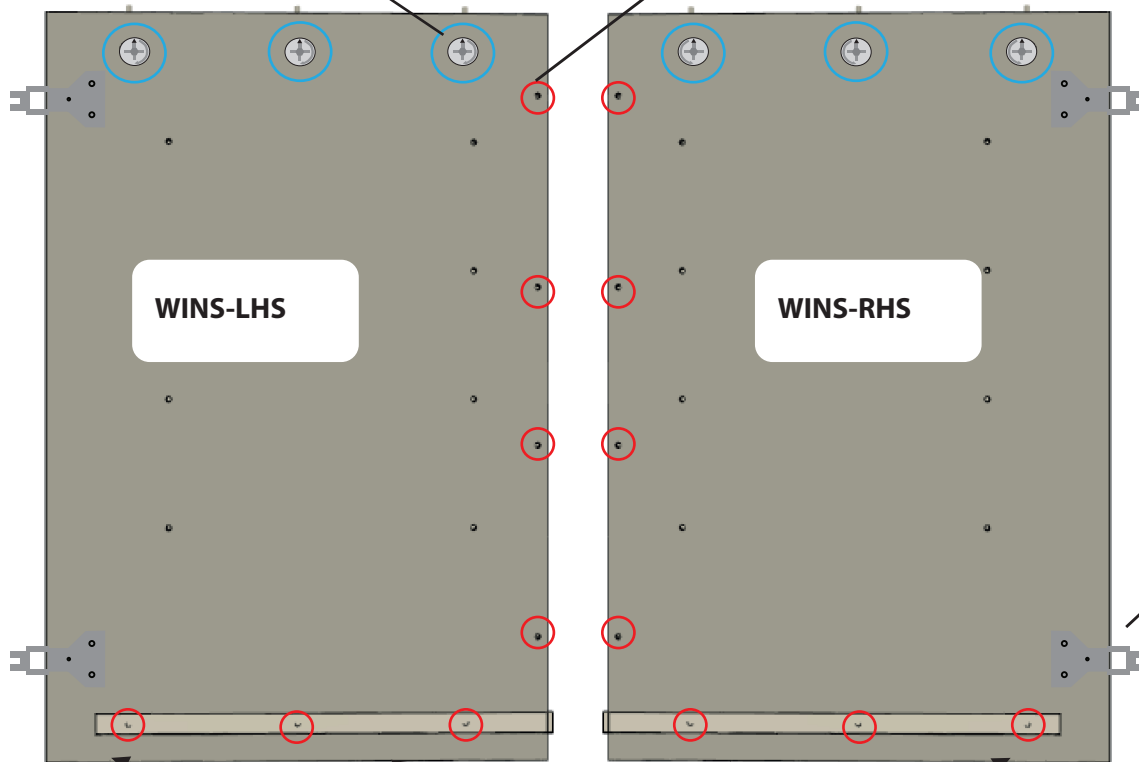

Attach hinges AXI-HINGE-M using pre fitted screws and 35-15S as shown



Attach angle brackets as shown using screws 35-17S

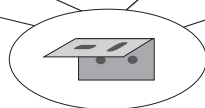

## STEP 2

You will need to open box -

WINS-TDB

Insert CL1 Locks into the holes as indicated with a blue circle

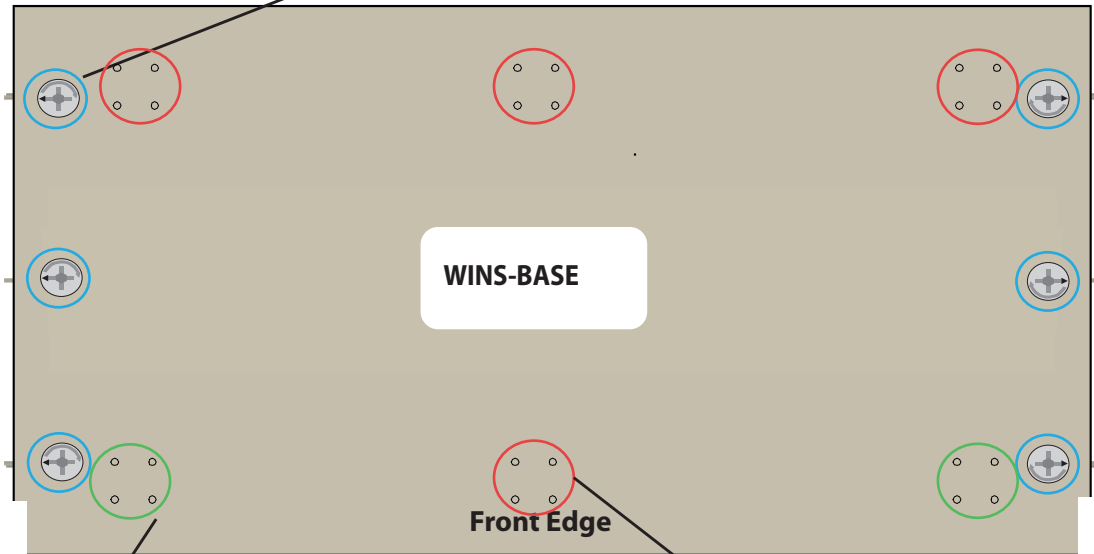

Attach castors with brakes C3 with screws 35-17S as shown to holes marked with green circles



Attach castors C2 with screws 35-17S as shown to holes marked with red circles

### STEP 3

You will need to open box -

WINS-BACK

Insert CL1 Locks into the holes as indicated with a blue circle

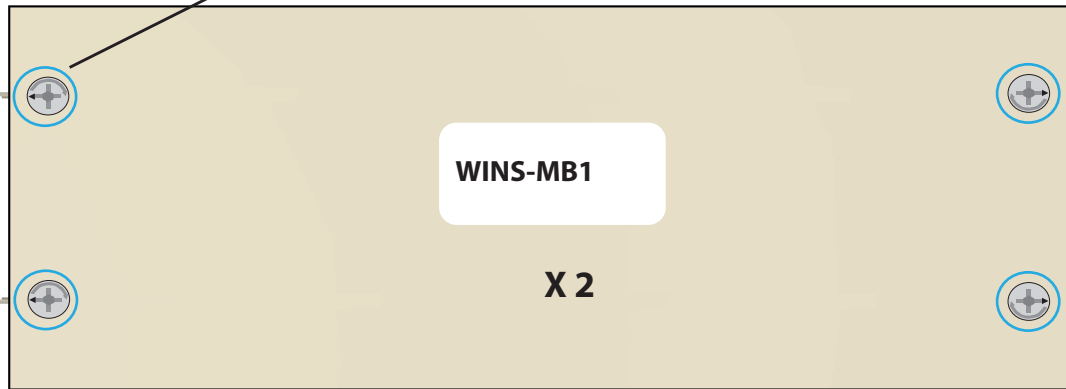

### STEP 4

Attach the Base to the left hand side by slotting the panel onto the connecting bolts and tightening the connecting locks in the base. Then secure the base to the sides using the angle brackets you have already attached to the sides (using screws 35-17S).

Then fix the two MB1 backs to the left hand side as shown below. You can choose to have the connecting locks showing on the inside of the unit or the outside by rotating the panels.

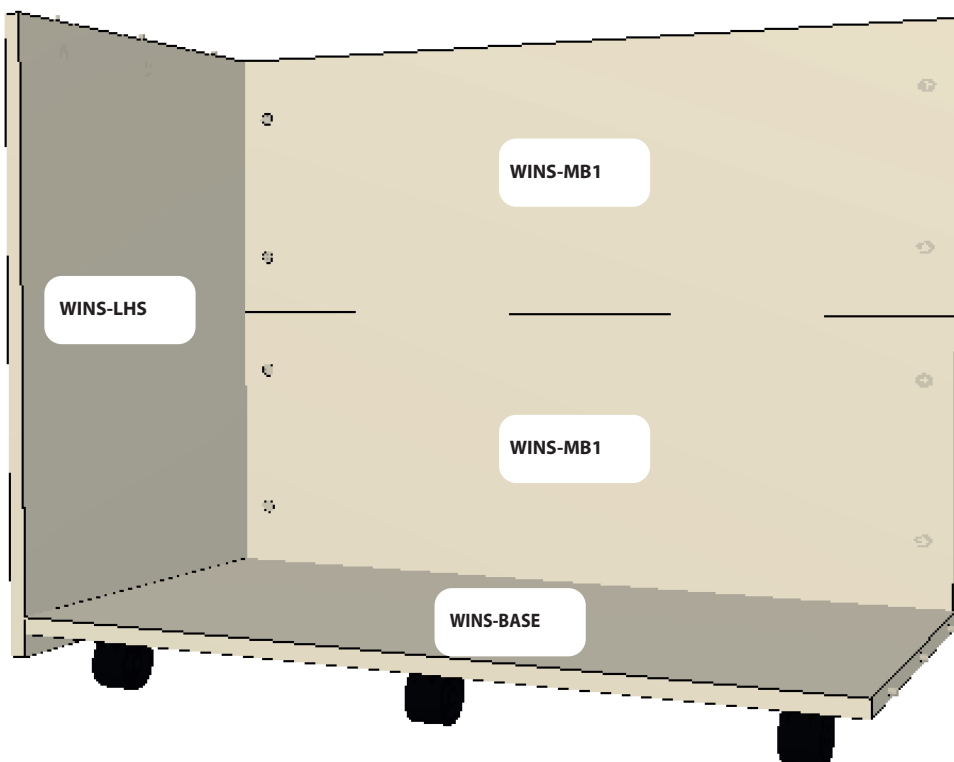

## STEP 5

Attach the RHS to the section you have already constructed, tighten all of the connecting locks and secure the base to the right hand side with the angle brackets as in step 4.

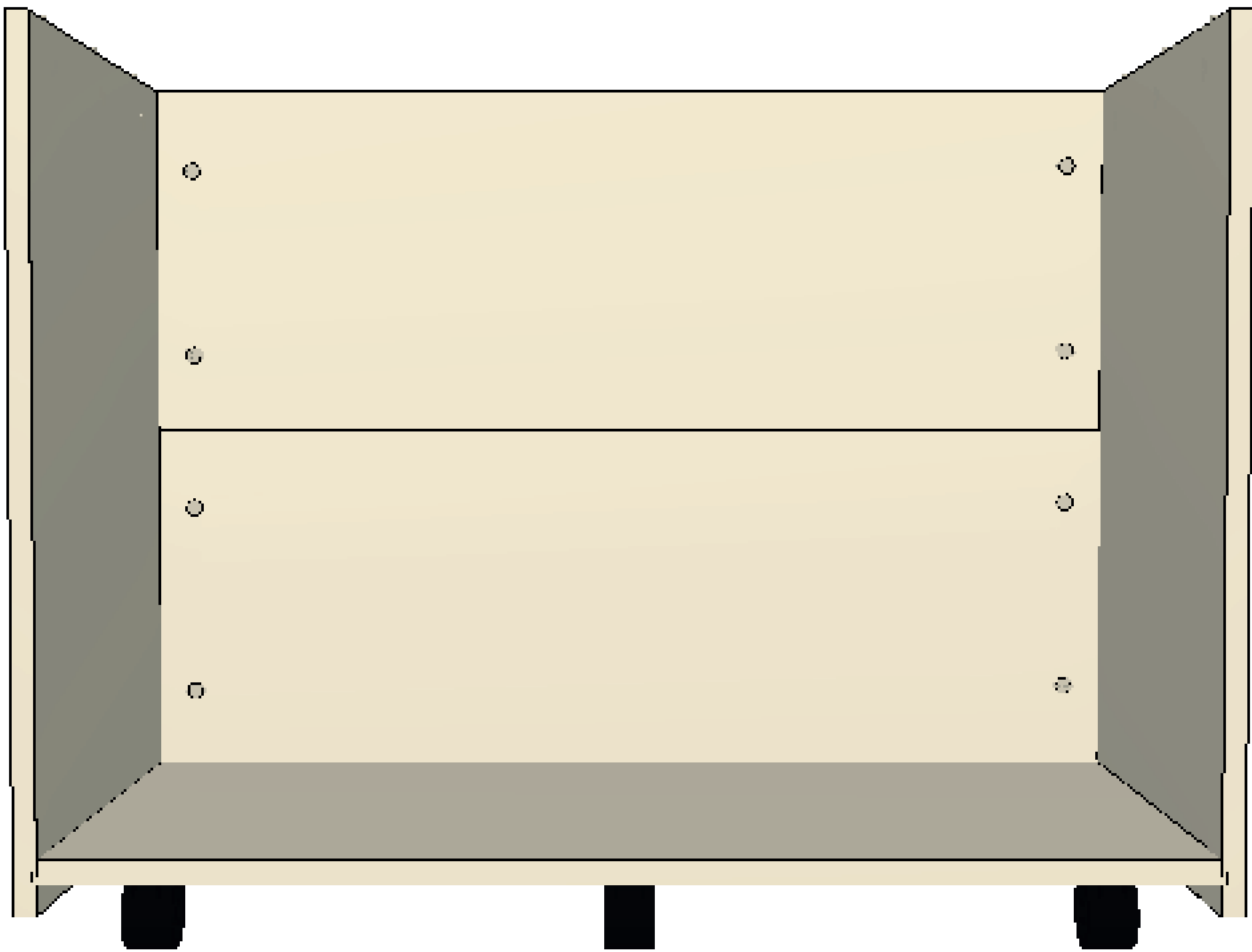

## STEP 6

Attach the WINS-CD to the base of the section you have already constructed. Screw CB1 connecting bolts into the two holes in the base and then secure with CL1 connecting locks in the WINS-CD.

It is important to ensure you have the WINS-CD panel the correct way up. You will see a label which states TOP on this panel and this should be at the top when fitted.

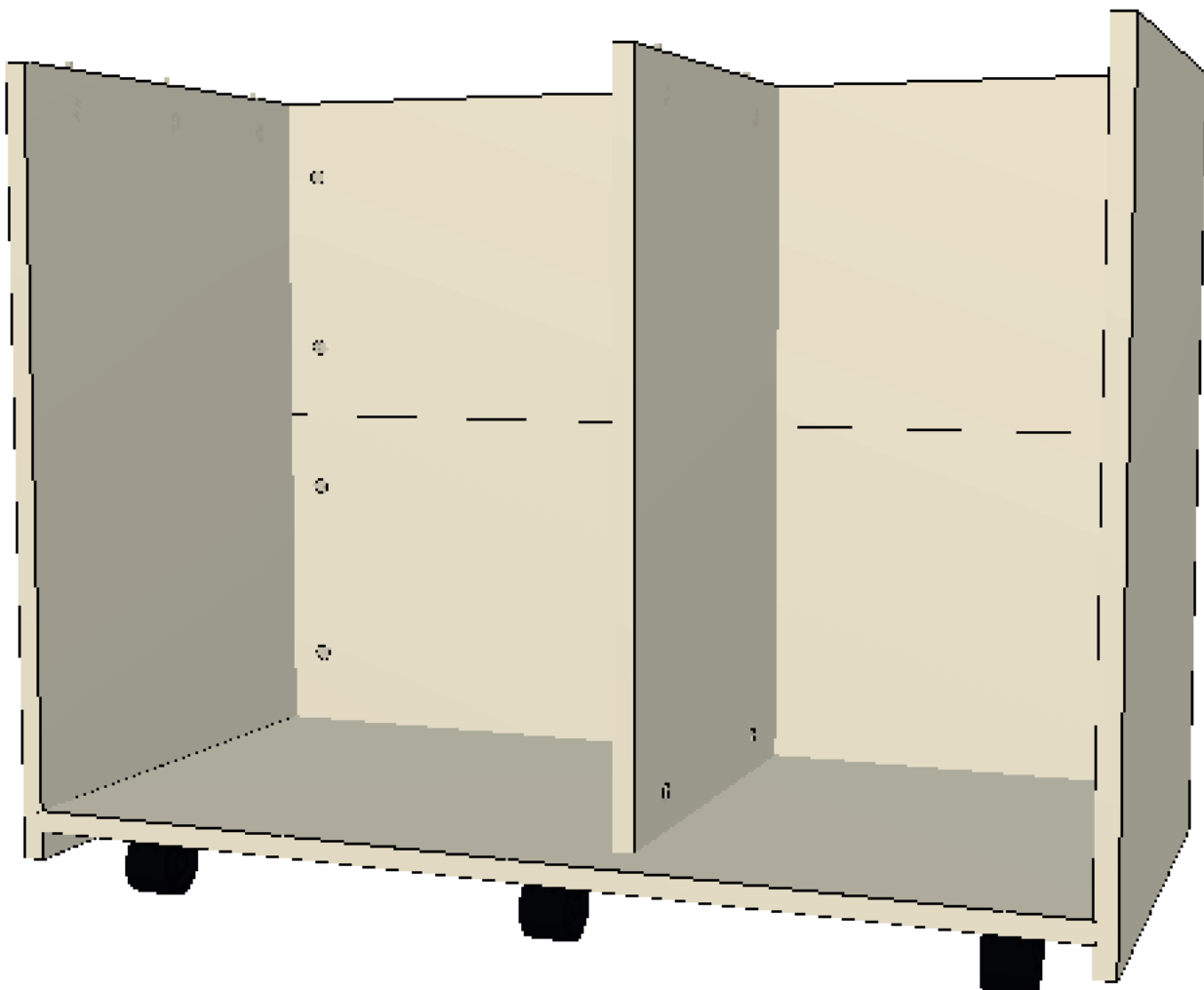

# STEP 7

Attach the WINS-TOP to the the section you have already constructed as shown below. Screw CB1 connecting bolts into the six holes in TOP panel and then secure with CL1 connecting locks in the WINS-CD and the left and right hand sides.

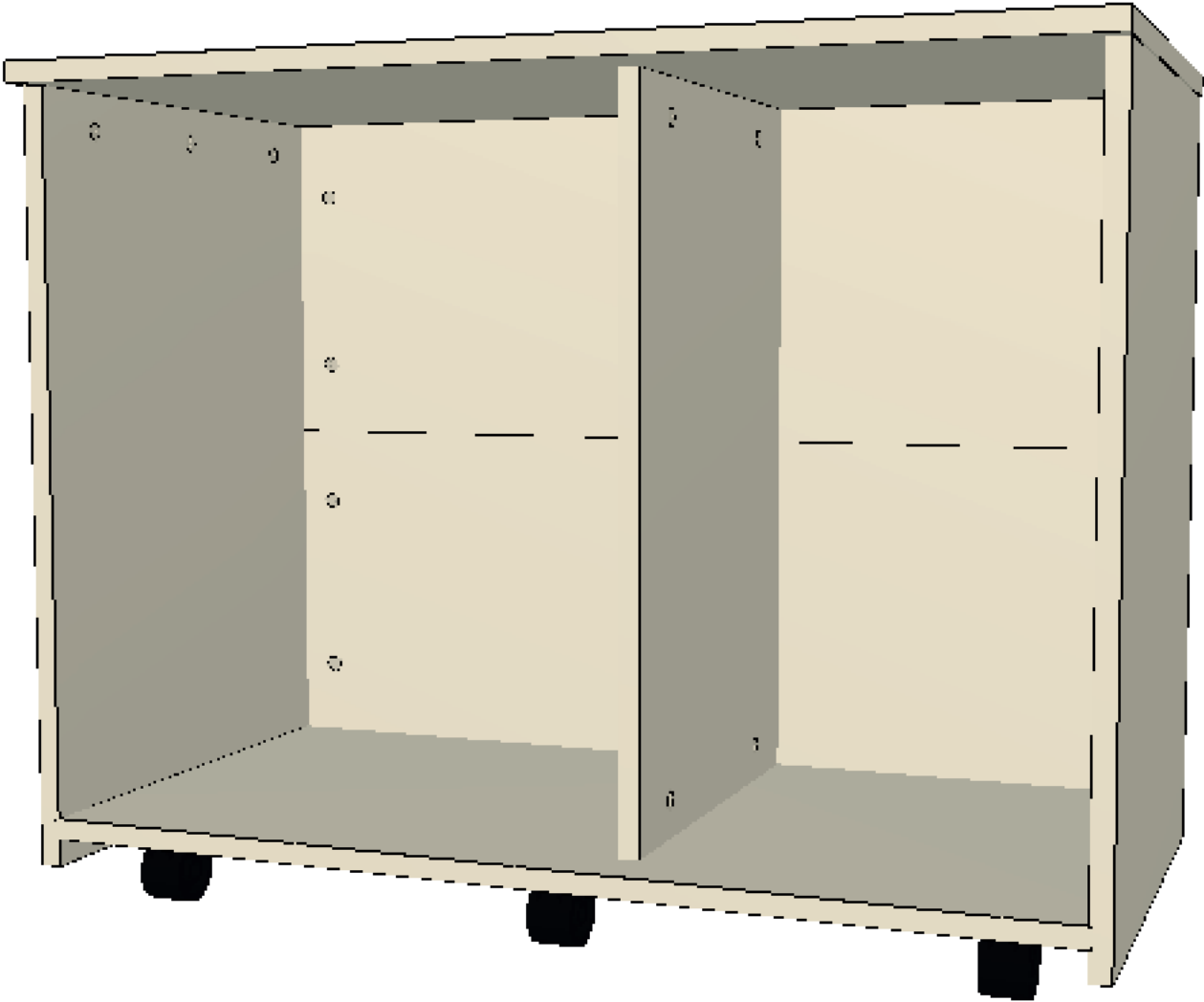



## STEP 8

You will need to open box -

WINS-SH

Below you will see the placement for all for all of the shelves.

To fit the shelves insert shelf pegs SP3 into the holes for each shelf. Ensure that the flat surface of the peg is facing up. Once the shelf has been placed onto the pegs tap the centre of the shelf with your hand to lock the shelf onto the grips on the peg. This will stop the shelf sliding when taking storage containers out of the unit.

Insert this way up



Place all shelves onto shelf pegs and tap down onto centre of shelves with your hand to lock onto pegs to prevent shelf sliding

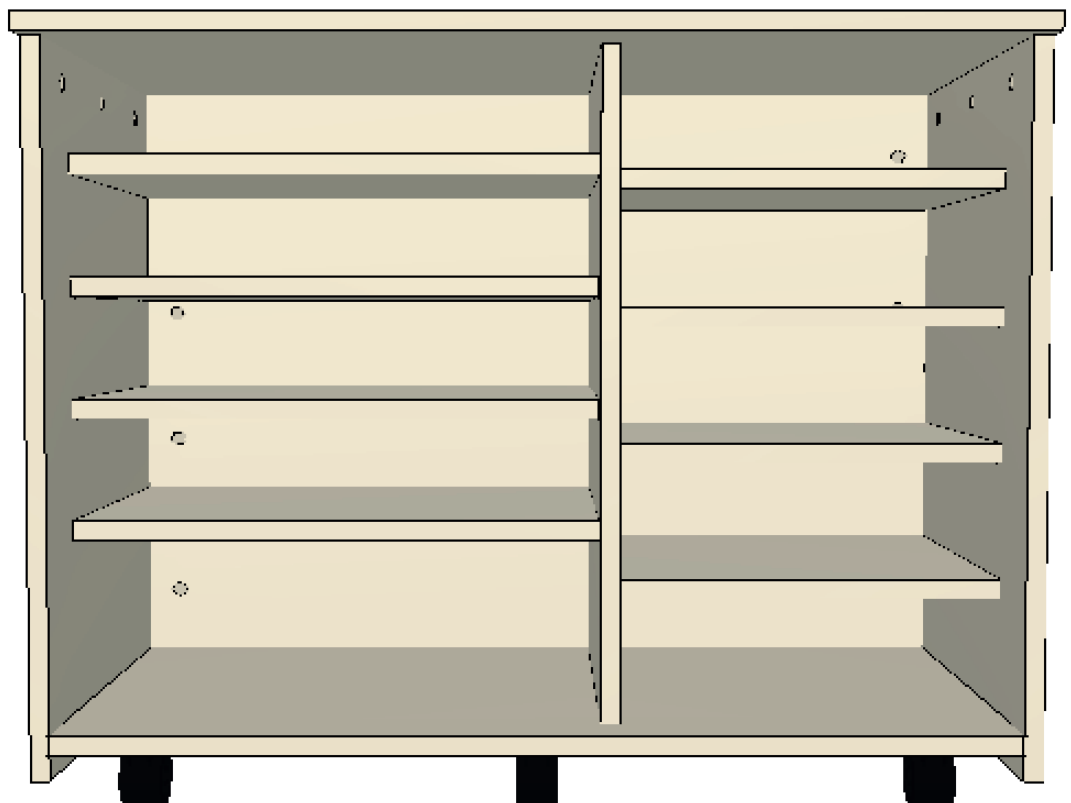

## STEP 9

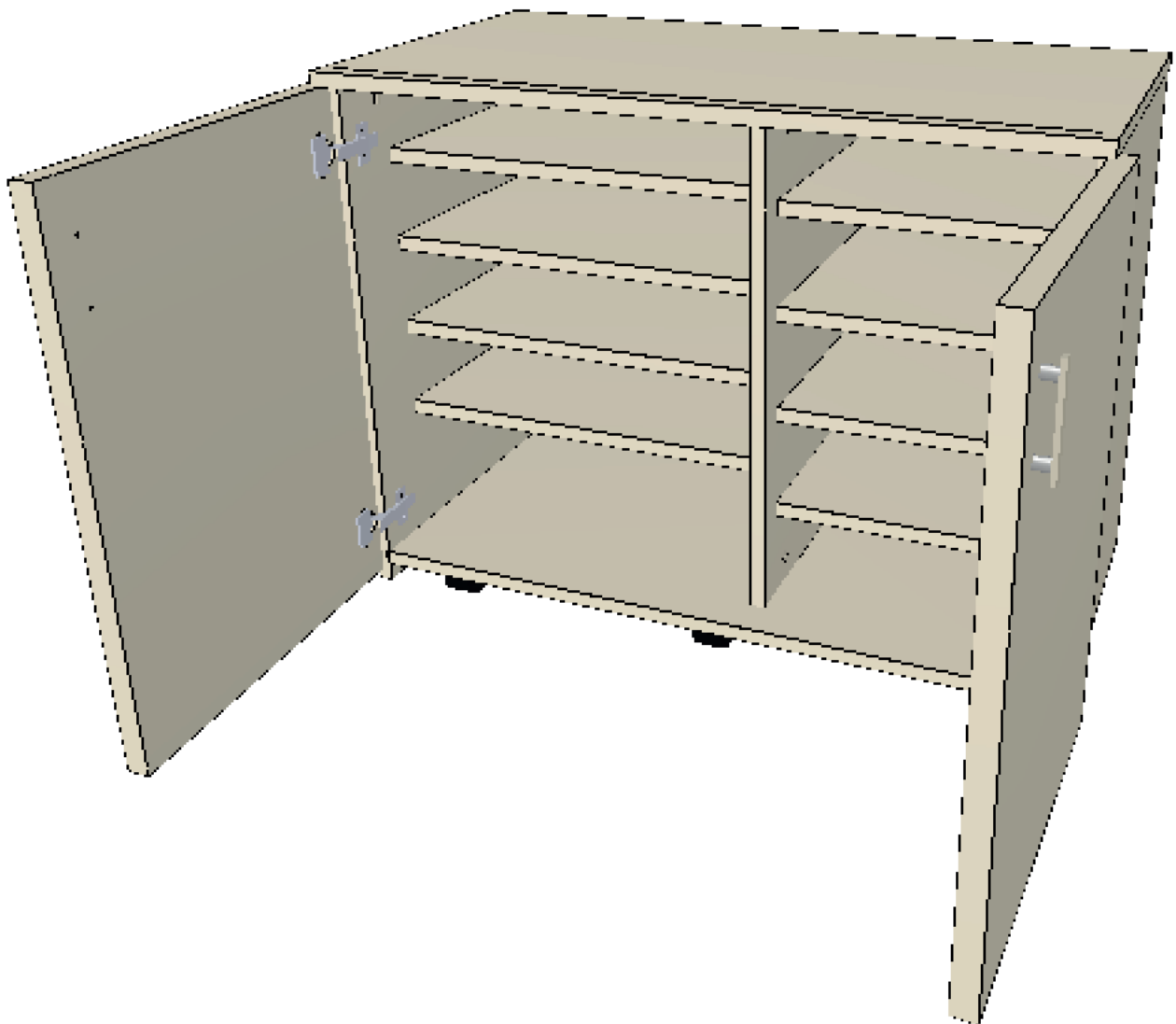

Take your two doors and insert caster C4  into the prefitted bracket on the bottom of each door. Fit the two handles using the screws provided.

Then fit your doors by inserting the metal bracket which you have already fixed to each side into the receiving part which is pre fitted to the door and then tighten the locking screw. You may find it easier to do this if you loosen the locking screw a little before insert the hinge bracket. At this point ensure the wheel as at the bottom of the door and the handle at the top.



## STEP 10

Position your doors so that they are open no more than 90 degrees so that they will support your desk panel.

Attach hinges H3  using screws 35-15S  to the top (WINS-TOP). Then place the desk on top of the doors and attach the hinges to the desk panel.

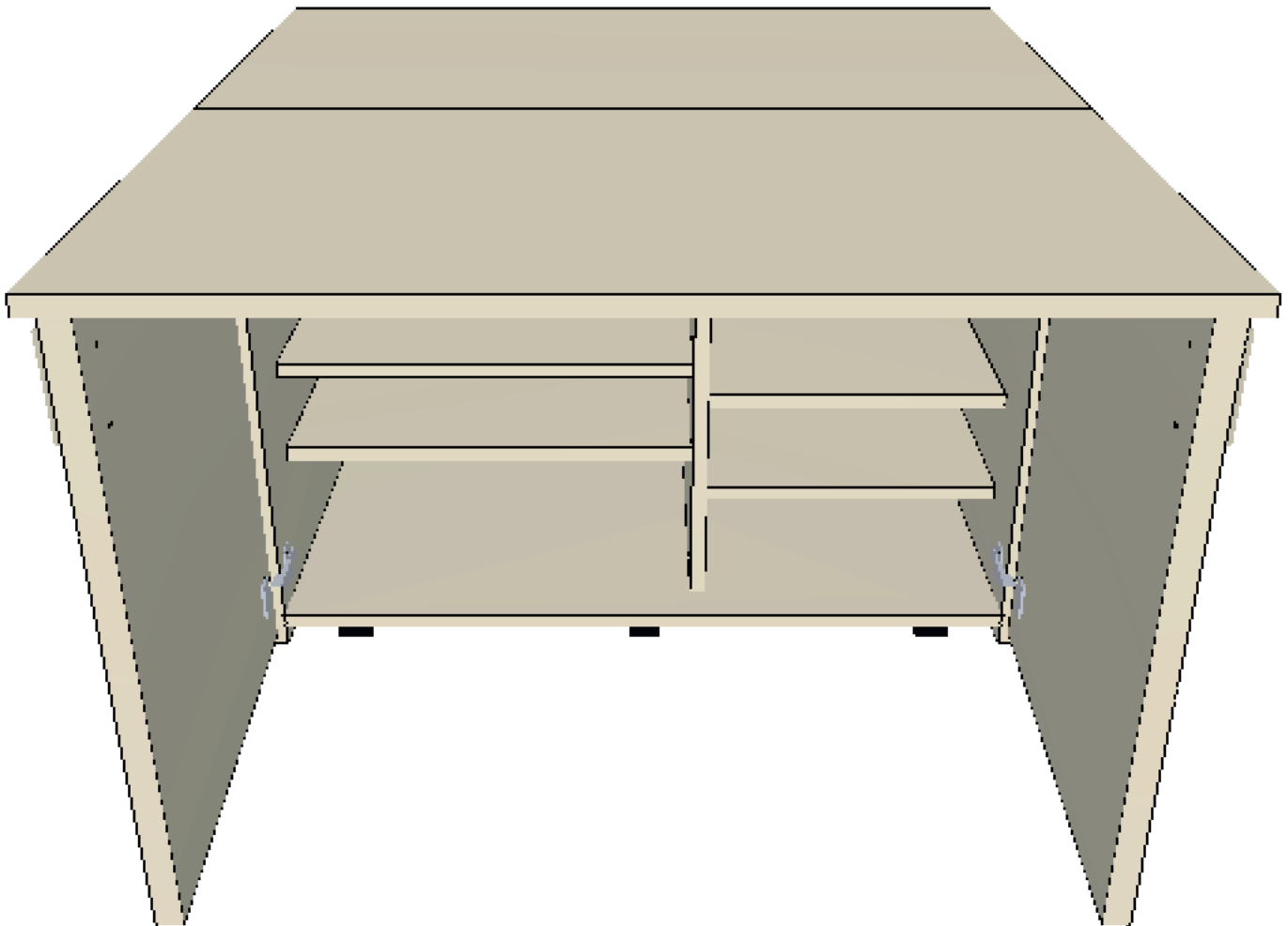

## STEP 11

.Place your storage containers into you unit as shown below.



### IMPORTANT SAFETY INFORMATION

**When the desk is in use always ensure it is fully supported on the doors - they must be open no more than 90 degrees.**

**FAILURE TO FOLLOW THESE INSTRUCTIONS MAY RESULT IN DAMAGE TO YOUR UNIT AND /OR INJURY**

The Storeaway Winsford unit is designed and manufactured in the UK by:

