

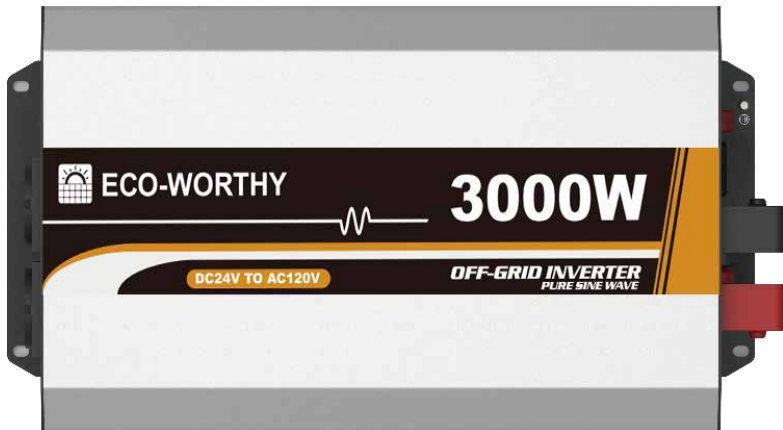

ECO-WORTHY

**3000W 24V
PURE SINE WAVE
OFF-GRID INVERTER
(USER MANUAL)**



Contents

| | |
|---|----|
| Important Safety Instructions | 1 |
| 1 Overview..... | 5 |
| 2 Appearance | 6 |
| 3 Naming rule | 7 |
| 4 Connection diagram..... | 9 |
| 5 Installation..... | 9 |
| 5.1 Attentions..... | 9 |
| 5.2 Wire size and circuit breaker | 10 |
| 5.3 Mounting | 11 |
| 6 Parameters setting | 15 |
| 6.1 Power Saving Mode..... | 15 |
| 6.2 Other parameters..... | 17 |
| 7 Protections..... | 19 |
| 8 Troubleshooting..... | 21 |
| 9 Maintenance | 21 |
| 10 Specifications..... | 22 |

Important Safety Instructions







Please reserve this manual for future review.

This manual contains instructions on the safety, installation, and operation of the IPT series high-frequency pure sine wave inverter ("inverter" as referred to in this manual).

1. Explanation of Symbols

Please read related literature accompanying the following symbols to enable users to use the product efficiently and ensure personal and property safety.

Please read the literature accompanying the following symbols.

| Symbols | Definition |
|---|--|
| TIP | Indicates any practical advice for reference |
|  | IMPORTANT: Indicates a critical tip during the operation, if ignored, may cause the device to run in error. |
|  | CAUTION: Indicates potential hazards. If not avoided, it may cause the device to be damaged. |
|  | WARNING: Indicates the danger of electric shock. If not avoided, it would cause casualties. |
|  | WARNING HOT SURFACE: Indicates the risk of high temperature, if not avoided, would cause scalds. |
|  | Read the user manual carefully before any operation. |
|  | The entire system should be installed by professional and technical personnel. |



2. Requirements for Professional and Technical Personnel

- Professionally trained;
- Familiar with related safety specifications for the electrical system;
- Read this manual carefully and master related safety cautions.

3. Professional and Technical Personnel is Allowed to do



- Install the inverter to a specified location.
- Conduct trial operations for the inverter.
- Operate and maintain the inverter.

4. Safety Cautions Before Installation



| | |
|---|---|
|  <p>IMPORTANT</p> | <p>When you receive the inverter, check whether there is any damage in transportation. Contact the transportation company, our local distributor, or our company for any problem.</p> |
|  <p>CAUTION</p> | <ul style="list-style-type: none">• When placing or moving the inverter, follow the instructions in the manual.• When installing the inverter, evaluate whether the operation area exists arc danger.• The inverter needs to be connected to a battery. The battery's minimum capacity (Ah) is recommended to be five times the current that equals the inverter's rated output power divided by the battery's voltage. |
|  <p>WARNING</p> | <ul style="list-style-type: none">• Keep the inverter out of the reach of children.• This inverter is an off-grid type. It is strictly prohibited to connect the inverter to the grid. Otherwise, the inverter will be damaged.• This inverter is only allowed for stand-alone operation. It is prohibited to connect multiple units in parallel or series. Otherwise, the inverter will be damaged. |

5. Safety Cautions for Mechanical Installation

| | |
|---|---|
|  <p>WARNING</p> | <ul style="list-style-type: none">• Before installation, ensure the inverter has no electrical connection.• Confirm enough heat dissipation space for the inverter before installation. Do not install the inverter in a harsh environment such as humid, salt spray, corrosion, greasy, flammable, explosive, or dust accumulation. |
|---|---|

| | |
|---|--|
|  <p>CAUTION</p> | <ul style="list-style-type: none"> • Check whether wiring connections are tight to avoid the danger of heat accumulation due to loose connections. • The protective grounding is connected to the ground. The cross-section of the wire should not be less than 4mm². • The DC input voltage must strictly follow the parameter table. Too high or too low DC input voltage will affect the inverter's normal operation and damage it. • It is recommended that the connection length between the battery and the inverter be less than 3 meters. If greater than 3 meters, please reduce the current density of the connection wire. • A fuse or breaker should be used between battery and Inverter; the fuse or breaker's rated current should be twice the inverter rated input current. • DO NOT install the inverter close to the flooded lead-acid battery because the terminals' sparkle may ignite the hydrogen released by the battery. |
|  <p>WARNING</p> | <ul style="list-style-type: none"> • The AC output terminal is only for the load connection. Do NOT connect it to another power source or utility. Otherwise, the inverter will be damaged. Turn off the inverter when connecting loads. • It is strictly forbidden to connect a transformer or a load with a surge power (VA) exceeding the overload power at the AC output port. Otherwise, the damage will be caused to the inverter. • Do not connect battery chargers or other similar products to the input terminal of the inverter. Otherwise, the inverter will be damaged. |

7. Safety Cautions for Controller Operation

| | |
|---|--|
|  <p>WARNING HOT SURFACE</p> | <p>When the inverter is working, the cover temperature is very high because of the accumulated heat; please do not touch it.</p> |
|  <p>CAUTION</p> | <p>When the inverter is running, please do not open the cabinet.</p> |
|  <p>WARNING</p> | <p>The inverter's AC output is of high voltage, do not touch the wiring connection to avoid electric shock.</p> |

8. Dangerous Operations Which Would Cause an Electric Arc, Fire, or Explosion

- Touch the wire end that hasn't been insulation treated and may be electriferous.
- Touch the wiring copper row, terminals, or internal inverter modules that may be electriferous.

- The connection of the power cable is loose.
- Screw or other spare parts inadvertently falls into the inverter.
- Improper operations by untrained non-professional or technical personnel.

| | |
|---|---|
|  | <p>Once an accident occurs, it must be handled by professional and technical personnel. Improper operations would cause more serious accidents.</p> |
|---|---|

9. Safety Cautions for Stopping the Inverter

- The internal conductive modules could be touched after the inverter stopped running for five minutes.
- The inverter is allowed to restart after removing the faults, which affects the safety performance.
- There are no serviceable parts inside. If any maintenance service is required, please contact our local distributor or the service personnel.

| | |
|---|---|
|  | <p>Do NOT touch or open the shell after the inverter is powered off within ten minutes.</p> |
|---|---|

10. Safety Cautions for Inverter Maintenance

- It is recommended to check the inverter with testing equipment to ensure no voltage and current.
- When conducting electrical connection and maintenance, post a temporary warning sign or put up barriers to prevent the unrelated personnel from entering the electrical connection or maintenance area.
- An improper operation of the inverter may cause personal injury or equipment damage.
- It is recommended to wear an antistatic wrist strap or avoid unnecessary contact with the circuit board.

Overview

The IPT series, a high-frequency sine wave inverter, adopts a fully digital intelligent design and voltage-current dual closed-loop control algorithm. Featured with fast response, high conversion efficiency, low Total Harmonic Distortion(THD), and high reliability running, the IPT series can be widely used in the DC-AC off-grid systems (such as vehicle systems, security monitoring systems, emergency lighting systems, household power systems, field power systems, and other systems requiring higher power quality).

Features:

- Pure sine wave output
- Input to output electrical isolation
- Output power factor up to 1
- Input Protection: Low-voltage, Over-voltage
- Output Protection: Overload, Short circuit, Overheating
- RS485 com. port to realize remote monitoring①
- External switch design, matched with EPEVER products, to expand inverter control function and reduce power consumption
- Diversified AC output sockets
- EN/IEC62109-1/2, EN61000-6-2/4, and FCC approved

① For inverters with 12V/24V input voltage, the RS485/RJ11 port has NO communication isolation design. This function (communication isolation design) is just for inverters with 48V input voltage.

Appearance

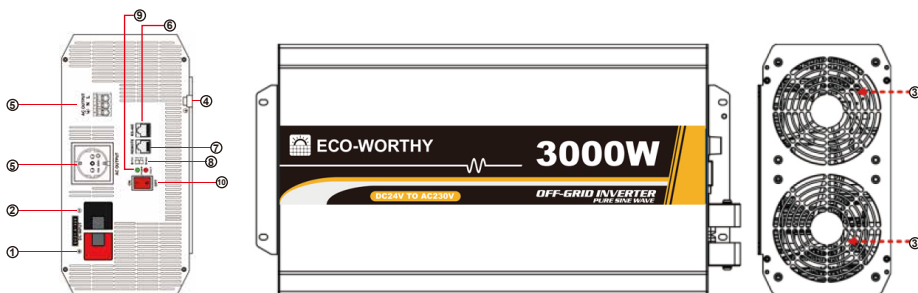

CAUTION

The appearance varies with different product models; please refer to the actual product appearance.

| | | | |
|---|----------------------------|---|---|
| ① | DC input terminal positive | ⑥ | RS485 communication port ③ |
| ② | DC input terminal negative | ⑦ | Remote switch port (RJ11, Reserved) |
| ③ | Cooling fan ① | ⑧ | External switch port (To connect an external relay) |
| ④ | Grounding terminal | ⑨ | Indicator ④ |
| ⑤ | AC output port ② | ⑩ | Inverter switch |

① Cooling Fan

• Conditions to start the cooling fan:

The heat sink temperature is higher than 45℃ or The internal inverter temperature is higher than 45℃ or The output power is higher than 50% of the rated power

• Conditions to stop the cooling fan:

The heat sink temperature is lower than 40℃ and The internal inverter temperature is lower than 40℃ and The output power is lower than 40% of the rated power

② The AC output port varies with different products. Please refer to chapter

3 Naming Rule for the Specific Supported Types.

③ The RS485 communication port can be connected to the remote meter, Bluetooth module, WIFI module, PC, etc., for parameter setting and remote monitoring.





② Indicators include the Power indicator and Fault indicator. The indicator and buzzer status under different working conditions are shown in the table below.

| Power indicator | Fault indicator | Buzzer | Status |
|------------------------------|----------------------------|---------------|---|
| Green ON | Red OFF | No beeps | Output voltage normal |
| Green slowly flashing(1/4Hz) | Red OFF | Buzzer beeps. | Input under voltage |
| Green fast flashing (1Hz) | Red OFF | Buzzer beeps. | Input over voltage |
| Green OFF | Red ON solid | Buzzer beeps. | Inverter over temperature Heat sink over temperature |
| Green OFF | Red fast flashing (1Hz) | Buzzer beeps. | Load short-circuit |
| Green ON | Red slowly flashing(1/4Hz) | Buzzer beeps. | Overload |

Naming Rule

1.Instructions for the Aanti-Reverse and Anti-Surge Current Protection

| Product type | Suffix | Definition |
|----------------------------|--------|---|
| Standard products | No | Without reverse polarity and anti-surge current protection |
| Customized products | R | With reverse polarity protection, without anti-surge current protection |
| | S | Without reverse polarity protection, with anti-surge current protection |
| | RS | With reverse polarity and anti-surge current protection |

| Suffix | Instruction | Figure |
|--------|-----------------------|---|
| T | Terminal |  |
| E | European socket |  |
| UK | United Kingdom socket |  |
| N | American Socket |  |

GFCI Socket Needs to be Tested After Power-on to Ensure Proper Operation.

A.Preparation

Connect a circuit breaker and an AC load (it is recommended to use a night light to observe the status conveniently) to the GFCI socket. Turn on the inverter after confirming the wiring.

B.Testing

1) If the red LED is ON solid, it indicates that the GFCI socket is damaged; please replace a new one.

2) If the LED is green ON after it flashes in red three times, connect the circuit breaker, and the night light will be turned on. Then, press the "TEST" button to observe the testing status:

① The "TEST" button always pops up, and the night light keeps ON solid. It indicates that the GFCI wiring is an error; please correct it.

② The "TEST" button goes down, while the "RESET" button pops up. The LED and the night light are turned off, indicating the GFCI socket is normal (Note: Press the "RESET" button again to recover the load output).



CAUTION

For detailed product model Vs. AC output port; please refer to the "IPT Model List."

Connection Diagram

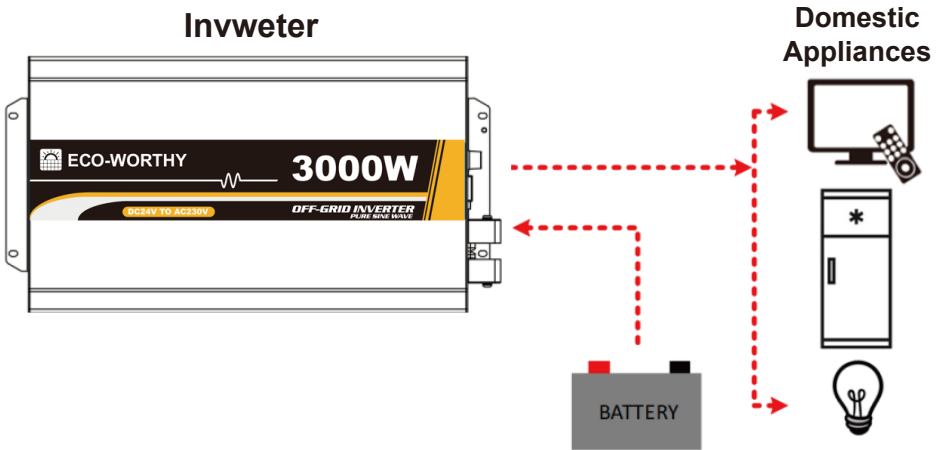

CAUTION

It is recommended to directly connect the inverter DC input terminal to the battery.

Installation

5.1 Attentions

- Read all the installation instructions carefully in the manual before installation.
- Be very careful when installing the batteries. When installing the open-type lead-acid battery, please wear eye protection and rinse with clean water for battery acid contact.
- Keep the battery away from any metal objects, which may cause a short circuit of the battery.

- Loose power connectors and corroded wires may result in high heat, melt wire insulation, burn surrounding materials, or cause a fire. Ensure tight connections and secure cables with cable clamps to prevent them from swaying in moving applications.
- The DC input voltage must strictly follow the parameter table. Too high or too low DC input voltage affects the normal operation and may damage the inverter. DC input 12V: Surge voltage < 20V. DC input 24V: Surge voltage < 40V. DC input 48V: Surge voltage < 80V.
- Select the system cables according to 3.5A/mm² or less current density.
- Avoid direct sunlight and rain infiltration when installing it outdoor.
- After turning off the power switch, do not open or touch the internal component immediately. Performing related operations after 10 minutes is recommended.
- Do not install the inverter in a harsh environment such as humid, salt spray, corrosion, greasy, flammable, explosive, or dust accumulation.
- The AC output is of high voltage, do not touch the wiring connection to avoid electric shock.
- To prevent injury, do not touch the fan while it is working.

5.2 Wire Size and Circuit Breaker

The wiring and installation methods conform to the national and local electrical code requirements.

Wire, terminals, and circuit breaker selection for battery

| Model | Battery wire size | Ring terminal | Circuit breaker |
|------------|-------------------------|---------------|-------------------------|
| IPT3000-21 | 25mm ² /3AWG | RNB60-6 | DC-100A(2P in parallel) |
| IPT3000-22 | 25mm ² /3AWG | RNB60-6 | DC-100A(2P in parallel) |

According to the recommended battery wire size, 2 battery wires, connected in parallel, are necessary for IPT1500-11, IPT1500-12, IPT2000-11, IPT2000-12, IPT3000-21, IPT3000-22, and IPT5000-42. 4 battery wires, connected in parallel, are necessary for IPT3000-11 and IPT3000-12.

| | |
|--|---|
|  CAUTION | The above wire size and circuit breaker size are for reference only; please choose a suitable wire and circuit breaker according to the actual situation. |
|--|---|

Wire and circuit breaker selection for AC output

| Model | Wire size | Circuit breaker |
|------------|-------------------------|-----------------|
| IPT3000-21 | 6mm ² /10AWG | AC/2P—50A |
| IPT3000-22 | 4mm ² /11AWG | AC/2P—25A |

| | |
|---|---|
|  CAUTION | <ul style="list-style-type: none">• The above wire size and circuit breaker size are for reference only; please choose a suitable wire and circuit breaker according to the actual situation.• The wire size is only for reference. If there is a long distance between the inverter and the battery, larger wires should be used to reduce voltage drop and improve system performance. |
|---|---|

5.3 Mounting

Installation procedures:

Step 1: Read this manual carefully.

Step 2: Determine the installation location and heat-dissipation space

The inverter should be installed in a place with sufficient airflow through the dissipation pad of the inverter. And a minimum clearance of 150mm from the upper and lower edges of the inverter is recommended to ensure natural thermal convection.

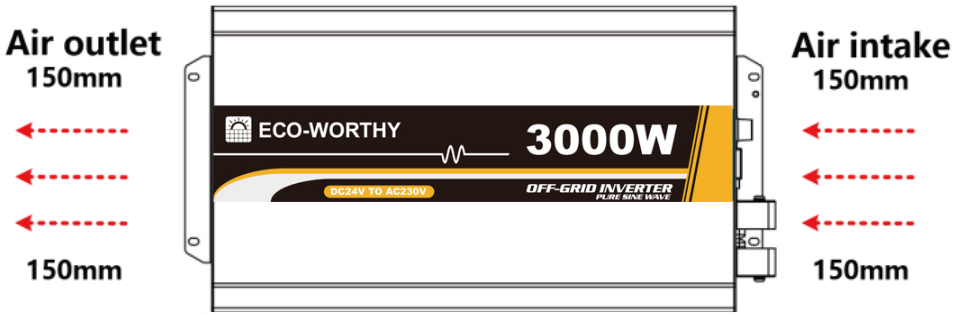

CAUTION

It is not recommended to install the product in an enclosed cabinet, where the device cooling will be influenced. If mounted in an enclosure cabinet, make sure there's effective ventilation and do not turn on all the loads in case the over temperature protection is caused.

Step 3: Wiring



CAUTION

- Turn off the inverter switch before wiring.
- Please do not connect the circuit breaker or fuse during the wiring and ensure that the poles' leads are connected correctly.

Wiring Sequence

1. Ground Connection

The wire size for the ground connection must be thicker or equal to the AC output wires. Refer to chapter 5.2 Wire size and circuit breaker for detailed wire size.

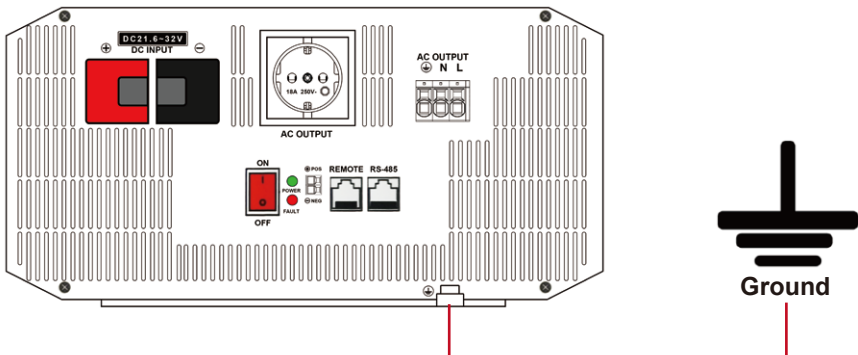

2. Battery Connection



CAUTION

A fuse must be installed on the battery side, conformed to the following requirements.

1. Fuse voltage is 1.5 to 2 times the inverter's rated voltage.
2. Fuse current is 2 to 2.5 times the inverter's rated current.
3. Distance between the fuse and the battery cannot be farther than 150mm.

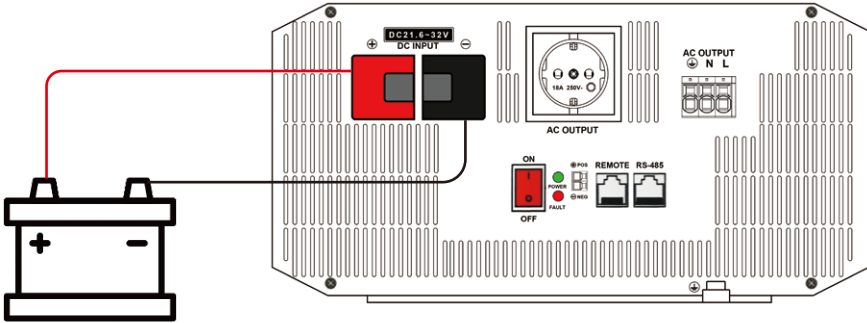

WARNING

- The AC loads shall be determined by the continuous output power of the inverter. The surge power of the AC load must be lower than the instantaneous surge power of the inverter, or the inverter will be damaged.

- The N pole of the AC output port cannot be grounded. If grounding the N pole is necessary, please purchase the IPower-Plus-B series.

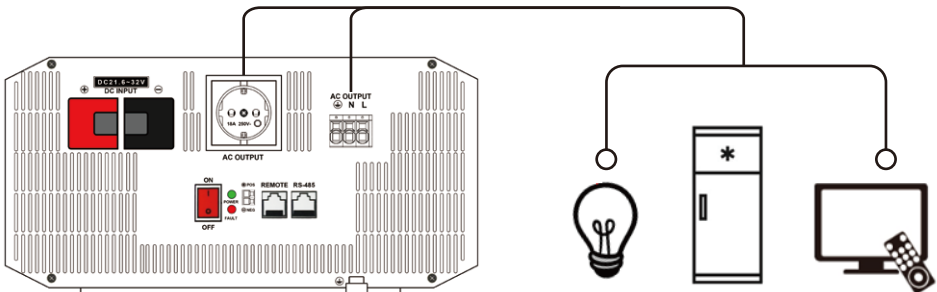

Optional Accessories Connection

1)RS485 Communication Port

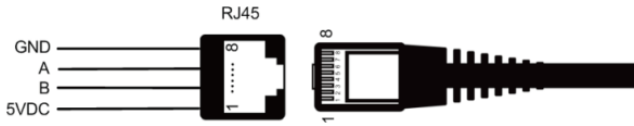

RJ45 Pin Definition:

| Pin | Definition | Instruction | Pin | Definition | Instruction |
|-----|------------|-------------|-----|------------|-------------|
| 1 | +5VDC | 5V/200mA | 5 | RS485-A | RS485-A |
| 2 | +5VDC | | 6 | RS485-A | |
| 3 | RS485-B | RS485-B | 7 | GND | Power GND |
| 4 | RS485-B | | 8 | GND | |

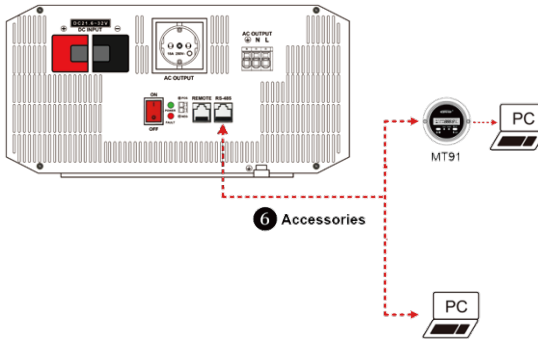

Step 4: Turn on the Inverter

- (1) Connect the breaker at the inverter input terminal or the fuse at the battery terminal.
- (2) Turn on the inverter switch, and the green indicator will be lighted on, which states a normal AC output.
- (3) Connect the breaker at the AC load terminal, turn on the AC loads, and check the system working status.



When supplying power for different loads, it is recommended to first turn on the load with a large impulse current. And then turn on the load with a smaller impulse current after the load output is stable.

(4) If the FAULT indicator flashes red and the buzzer alarms after powering the inverter, please immediately turn off the load and the inverter. Clear the faults according to chapter 8 Troubleshooting. After clearing the faults, please operate the inverter again by following the above steps.

Parameters Setting

IPT parameters such as power saving mode, baud rate, output voltage class, and output frequency class can be set on the remote meter, phone APP, or PC software. The following chapters take parameters setting on the remote meter as an example (for connection of the remote meter, please refer to chapter 5.3 Mounting).

6.1 Power Saving Mode

Users can enable the power saving mode and set the PSI/PSO value by the remote meter (The minimum power step is 1VA).

When the actual load power is lower than the PSI (the power to enter the power saving mode), the system will automatically switch to the power saving mode. And then, the device output is turned on for 1s and turned off for 5s.

When the actual load power exceeds the PSO (the power to exit the power saving mode), the inverter will automatically exit the power saving mode and resume work.

1) Enable power saving mode (PSE)

Step1: In the real-time interface of the remote meter, press and hold the  button to enter the parameters setting interface.

Step2: Click the  or  button to select the PSE parameter.



Step3: Press and hold the  button until the PSE parameter (OFF default) flashes.

Step4: Click the  or  button to set the PSE state.

- Select ON to enable the power saving mode.
- Select OFF to disable the power saving mode.





Step5: Press and hold the  button to confirm.

2) Set the Power to Exit the Power Saving Mode (PSO)

Step1: In the parameters setting interface, click the  or  button to select the PSO parameter.

Step2: Press and hold the  button until the PSO value flashes.



Step3: Click the  or  button to set the PSO parameter.

- Click the  button to decrease the PSO value by 1.
- Click the  button to increase the PSO value by 1.
- Press and hold the  button to increase the PSO value by 10. After ten adding, the PSO value will increase by 100 each time. When the  button is released, press and hold it again to repeat the above operation.

Note: The setting parameter cannot exceed the user define, or else; it will return to the initial value to start the loop.





Step4: Press and hold the  button to confirm.

3) Set the power to enter the power saving mode (PSI)

Step1: In the parameters setting interface, click the  or  button to select the PSI parameter.

Step2: Press and hold the  button until the PSI value flashes.

Step3: Click the  or  button to set the PSI parameter.

- Click the  button to decrease the PSI value by 1.
- Click the  button to increase the PSI value by 1.
- Press and hold the  button to increase the PSI value by 10. After ten adding, the PSI value will increase by 100 each time. When the  button is released, press and hold it again to repeat the above operation. Note: The setting parameter cannot exceed the user define, or else; it will return to the initial value to start the loop.



Step4: Press and hold the  button to confirm.

6.2 Other Parameters

Users can set the baud rate, output voltage class and output frequency class, etc. by the remote meter.

Operation:



Step1: In the real-time interface, press  for 2s to enter the parameter setting interface.

Step2: Click  or  to select the parameter to be configured.











Step3: Press  for 2s to enter the configuration interface of the specified parameter.

Step4: Click  or  to configure the parameter value.

Step5: Press  for 2s to confirm the configuration.

Step6: Click  +  to exit the current interface.

Parameters Setting Range:

| Display | Parameters | Default | Setting range |
|--|--|----------------------|----------------------------------|
|  VPT | Output voltage class | 220VAC | 220VAC/230VAC/240VAC |
| | | 110VAC | 100VAC/110VAC/120VAC |
|  FRE | Output frequency class | 220/230/240VAC: 50Hz | 50Hz/60Hz |
| | | 100/110/120VAC: 60Hz | |
|  BLT | LCD backlight time | 30s | 30s/ 60s/100s(ON solid) |
|  PSE | Power Saving Enable | OFF | ON/OFF |
|  PSI | Power Saving In | 20VA | 20VA ~ (20%*rated power) |
|  PSO | Power Saving Out | 40VA | (20VA + PSI) ~ (50%*rated power) |
|  BRS | Baud Rate Select ^② | 115200 | 9600/115200 |
|  LVD | Low voltage disconnect voltage ^③ | 12V: 10.8V | 12V: 10.5V~14.2V; step size 0.1V |
| | | 24V: 21.6V | 24V: 21V-30.2V; step size 0.1V |
| | | 48V: 43.2V | 48V: 42V-62.4V; step size 0.1V |
|  LVR | Low voltage reconnect voltage ^③ | 12V: 12.5V | 12V: 11.5V~15.2V; step size 0.1V |
| | | 24V: 25V | 24V: 22V-31.2V; step size 0.1V |
| | | 48V: 50V | 48V: 43V-63.4V; step size 0.1V |
|  LVR | Over voltage reconnect voltage ^③ | 12V: 14.5V | 12V: 11.5V~15.2V; step size 0.1V |
| | | 24V: 29V | 24V: 22V-31.2V; step size 0.1V |
| | | 48V: 58V | 48V: 43V-63.4V; step size 0.1V |
|  LVD | Over voltage disconnect voltage ^③ | 12V: 16V | 12V: 10.5V~14.2V; step size 0.1V |
| | | 24V: 32V | 24V: 21V-30.2V; step size 0.1V |
| | | 48V: 64V | 48V: 42V-62.4V; step size 0.1V |

① After configuring the parameters marked with ①, the inverter will restart automatically. It will resume work according to the new parameter value.

② Due to the length limit of the LCD displayed data. When the baud rate is set to 115200, the value displayed on the LCD is 1152.

③ For the parameters marked with ③, please set them by the input voltage rules in chapter 7 Protections. Otherwise, the parameter settings will not succeed.

Protections

1) Input Voltage Protection

• **The following rules must be followed when modifying the battery's input voltage parameters:**

A. Over voltage limiting voltage (16.2/32.2/64.4V) \geq Over voltage disconnect voltage \geq Over voltage reconnect voltage +1V.

B. Over voltage reconnect voltage \geq Low voltage reconnect voltage.

C. Low voltage reconnect voltage \geq Low voltage disconnect voltage +1V.

D. Low voltage disconnect voltage \geq Low voltage limiting voltage (10.5/21/42V).

• **Detailed status is shown as the following when the input voltage protection occurs.**

| Input Voltage Protection | Status |
|----------------------------------|--|
| Over voltage protection | The output is switched OFF immediately. The green indicator fast flashes. Buzzer beeps. |
| Over voltage recovery protection | The green indicator is ON solid. The output voltage is normal. |
| Low voltage protection | The output is switched OFF immediately. The green indicator Slowly flashes. Buzzer beeps. |
| Low voltage recovery protection | The green indicator is ON solid. The output voltage is normal. |



CAUTION

Although the inverter is supplied with the input over-voltage protection, the surge voltage cannot higher than 20V for the 12V system, not higher than 40V for the 24V system, and not higher than 80V for the 48V system. Otherwise, the inverter may be damaged.

2) Overload Protection

| | | |
|--|--|--|
| IPT3000-21 | S=1.2Pe (S: Output power; Pe: Rated power) | The output is switched OFF after 1 minute. Buzzer beeps. Red indicator slowly flashes. |
| | S=1.5Pe (S: Output power; Pe: Rated power) | The output is switched OFF after 30 seconds. Buzzer beeps. Red indicator slowly flashes. |
| IPT3000-22 | S=1.8Pe (S: Output power; Pe: Rated power) | The output is switched OFF after 10 seconds. Buzzer beeps. Red indicator slowly flashes. |
| | S≥2Pe(Rated input voltage) (S: Output power; Pe: Rated power) | The output is switched OFF after 5 seconds. Buzzer beeps. Red indicator slowly flashes. |
|  CAUTION | | |
| <p>When the overload protection happens, the AC output will shut down and cannot be recovered automatically. After cutting down some of your loads, you need to restart the inverter to recover the AC output.</p> | | |

3) Output Short Circuit Protection

| Faults | Instruction |
|---|--|
| The output is switched OFF immediately. Buzzer beeps. Red indicator fast flashes. | Note: When the short circuit protection happens, the AC output will be recovered automatically three times (recover after 5s, 10s, and 15s separately). After three times recovery attempts fail, you need to restart the inverter to recover the AC output. |

4) Inverter over Temperature Protection

| Faults | Instruction |
|--------------------------------|---|
| The red indicator is ON solid. | The inverter stops working after the temperature of the heat sink or the internal modules is higher than a set value. |
| Red indicator OFF | The inverter resumes work after the temperature of the heat sink or the internal modules is lower than a set value. |

Troubleshooting



A high voltage occurs inside the inverter. DO NOT try to repair or maintain the inverter by yourself, and it may cause an electric shock.

| NO. | Faults | Possible Reasons | Troubleshooting |
|-----|---|-----------------------------------|---|
| 1 | Green indicator Slowly flashes (1/4Hz) Red indicator turns OFF Buzzer beeps | The DC input voltage is too low. | Check whether the DC input voltage is lower than 10.8/21.6/43.2V by a multi-meter. The inverter resumes work after adjusting the input voltage. |
| 2 | Green indicator fast flashes (1Hz) Red indicator turns OFF Buzzer beeps | The DC input voltage is too high. | Check whether the DC input voltage is higher than 16/32/64V by a multi-meter. The inverter resumes work after adjusting the input voltage. |
| 3 | Green indicator is ON solid Red indicator slowly flashes (1/4Hz) Buzzer beeps | Overload | Check whether the AC load's power is within the inverter's rated power; clear the overload faults, and restart the inverter. |
| 4 | Green indicator turns OFF Red indicator fast flashes (1Hz) Buzzer beeps | Load short-circuit | Check the load connection carefully. Clear the short circuit faults and restart the inverter. |
| 5 | Green indicator turns OFF Red indicator is ON solid. Buzzer beeps | Inverter over-temperature | Improve the ventilation situation and cool the surrounding temperature. It is recommended to restart the inverter after the temperature drops. If the fault cannot be cleared after performing the above operations, decline the rated power. |

Maintenance

The Following Inspections and Maintenance Tasks are Recommended at Least Two Times Per Year for Good Performance.

- Make sure no block on airflow around the inverter. Clear up any dirt and fragments on the heat sink.
- Check all the naked wires to ensure insulation is not damaged by sun exposure, frictional wear, dryness, insects or rats, etc.
- Verify the indicator display is consistent with the actual operation.

- Confirm that terminals have no corrosion, insulation damage, high temperature, burnt/discolored sign, and tighten terminal screws to the suggested torque.
- Clear up dirt, nesting insects, and corrosion in time.
- Check and confirm that the lightning arrester is in good condition. Replace a new one in time to avoid damaging the inverter and other equipment.



WARNING

Risk of electric shock! Confirm all the power is turned off and all the capacitor's energy has been discharged before performing the above operations.

Specifications

| Model | IPT3000-21 | IPT3000-22 |
|------------------------------|--|---|
| Continuous output power | 3000W@35°C @Rated input voltage | |
| Surge power | 6000W@5S | |
| Surge current when power on① | < 100A | |
| Output voltage | 100VAC/110VAC (±3%); 120VAC (-7%~+3%) | 220VAC (±3%); 230VAC (-6%~+3%); 240VAC (-9%~+3%) |
| Output frequency | 50/60Hz ± 0.2% | |
| Output wave | Pure Sine Wave | |
| Output distortion THD | THD ≤ 5% (Resistive load) | THD ≤ 3% (Resistive load) |
| Load power factor | 0.2 ~ 1 (Load power ≤ Continuous output power) | |
| Rated input voltage | 24VDC | |
| Input voltage range | 21.6 ~ 32.0VDC | |
| Rated output efficiency② | > 87.0% | > 90.0% |
| Max. output efficiency③ | > 91.5% (30% loads) | > 94.0% (30% loads) |
| Idle current | < 0.15A | |
| No-load current | < 1A | |
| RS485 com. port | 5VDC/200mA | |
| Mechanical Parameters | | |
| Input terminal | M6 | |
| Dimension (L x W x H) | 521 × 270 × 143mm | |
| Mounting size | 495 × 145mm | |
| Mounting hole size | Φ6mm | |
| Net Weight | 8.8kg | 8.5kg |

- ① The "Surge current when power on" parameter is for the customized products with an anti-surge function (whose product model has "S"). For other products, the actual surge current prevails.
- ② It means the rated output efficiency when the load power equals the "continuous output power" under the rated DC input voltage.
- ③ It means the max. output efficiency when the inverter is connected with different loads under the rated DC input voltage.

Environment Parameters

| | |
|----------------------------|---|
| Working temperature | -20 °C ~ +60 °C (Refer to the Derating Curve) |
| Storage temperature | -35 °C ~ +70 °C |
| Relative humidity | ≤ 95% (N.C.) |
| Enclosure | IP20 |
| Altitude | < 5000m (If the altitude exceeds 1000 meters, the rated power will be reduced according to IEC62040.) |

Certification

| Category | Standard No. |
|---|--|
| Safety | EN/IEC62109-1, UL458 (Products with 12/24V input voltage support), CSA C22.2#107.1 |
| EMC(Electromagnetic compatibility) | EN61000-6-2/EN61000-6-4, FCC 47 CFR Part 15, Subpart A |
| RoHS | IEC62321-3-1 |