

INTRODUCTION:

The **ES15** strike is designed to be surface mounted onto a door frame on a single swing door equipped with a surface mounted rim cylinder lock with a sprung tongue lock. Rated strength 1200 kg

ES15 - Unmonitored weather resistant (IP56) Electric Door Strike

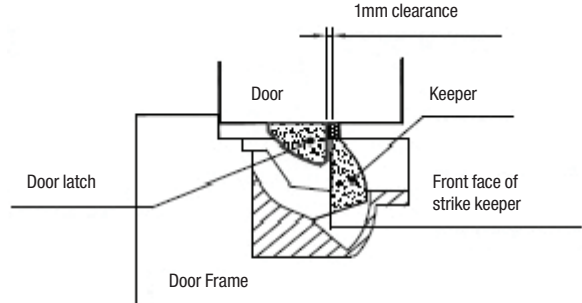
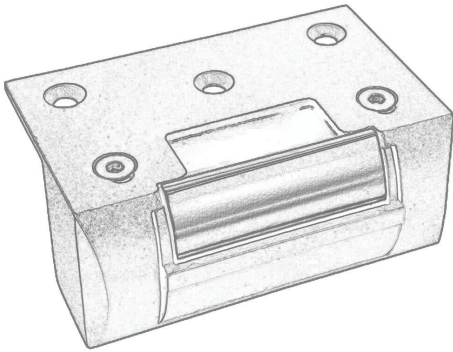

When the door is closed, ensure that there is no back pressure on the front of the strike keeper

WIRING AND POWER INPUT REQUIREMENTS:

- The **ES15** is supplied with two voltage selection plugs for operation on either 12VDC or 24VDC.
- If space does not permit the use of the plug/s provided they may be cut off and wired as shown below.
- AC power may also be used by adding a bridge rectifier -- see below.
- Note that direct connection of AC power will damage the strike and is not covered by warranty.
- Power to the **ES15** series is not polarized.

SELECT EITHER THE 12V OR 24V SELECTOR PLUG TO SUIT THE VOLTAGE BEING USED, OR THE PLUGS MAY BE CUT OFF AND WIRED AS BELOW.

ALTERNATE WIRING WITHOUT VOLTAGE SELECTION PLUGS

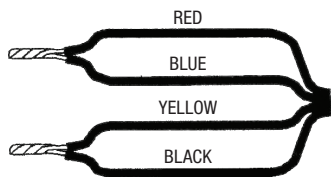

12VDC (0.20A)
Non Polarised

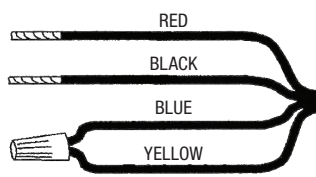

24VDC (0.10A)
Non Polarised

ALTERNATE WIRING USING AC 12 - 24 VOLTS WITH A BRIDGE RECTIFIER

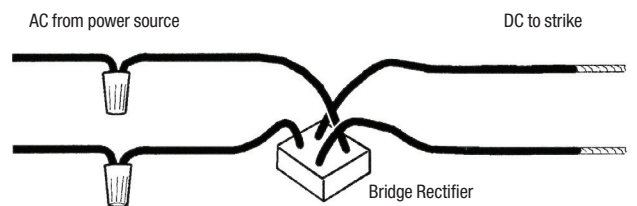

For AC operation a Jaycar ZR1304 Bridge Rectifier is recommended

PROBLEM	POSSIBLE CAUSE	SOLUTION
DOOR WILL NOT LOCK	INCORRECT VOLTAGE SELECTION	CHECK VOLTAGE PLUG BEING USED
WILL NOT WORK IN ONE ORIENTATION	24V RATHER THAN 12V SELECTED	CHECK VOLTAGE PLUG OR WIRING

DIMENSIONS AND MOUNTING OPTIONS

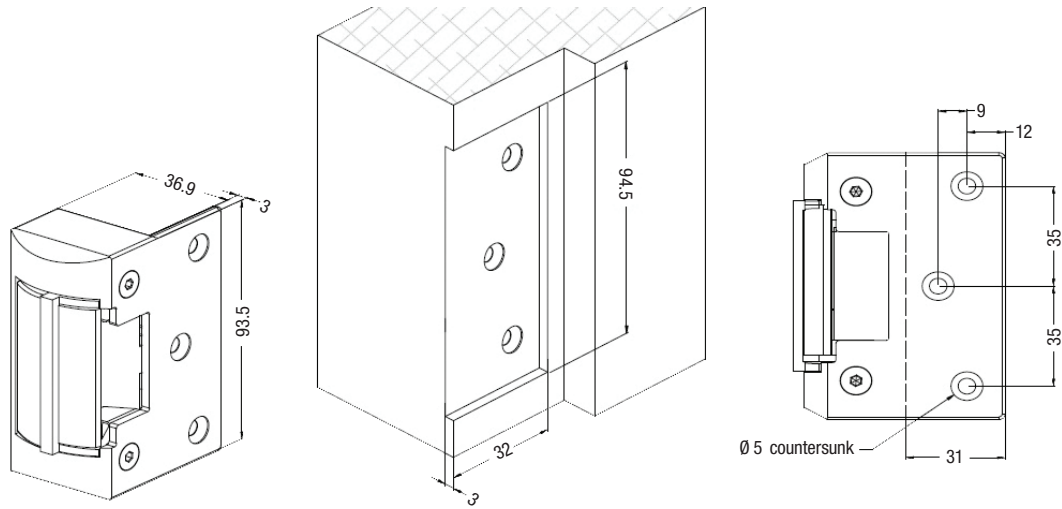

CHANGING LOCK FUNCTION FROM FAIL SAFE TO FAIL SECURE

WARNING:

DO NOT ATTEMPT TO SWIVEL THE KEEPER WHILE CHANGING THE FUNCTION, THIS WILL DAMAGE THE BARBELL MECHANISM.

PROCEDURES TO CONVERT FAIL SECURE (FIGURE 4A) TO FAIL SAFE (FIGURE 4B):

- Step 1: Remove the security plug cover (2) with the provided security screw (1).
- Step 2: Remove the spring screw (3) from the opening hole.
- Step 3: Remove the Barbell (4) and replace in reverse position with long part in and short part out.
- Step 4: Replace the spring screw (3).
- Step 5: Refit the security plug cover (2).

PROCEDURES TO CONVERT FAIL SAFE (FIGURE 4B) TO FAIL SECURE (FIGURE 4A):

- Step 1: Remove the security plug cover (2) with the provided security screw (1).
- Step 2: Remove the spring screw (3) from the opening hole.
- Step 3: Remove the Barbell (4) and replace in reverse position with short part in and long part out.
- Step 4: Replace the spring screw (3).
- Step 5: Refit the security plug cover (2).

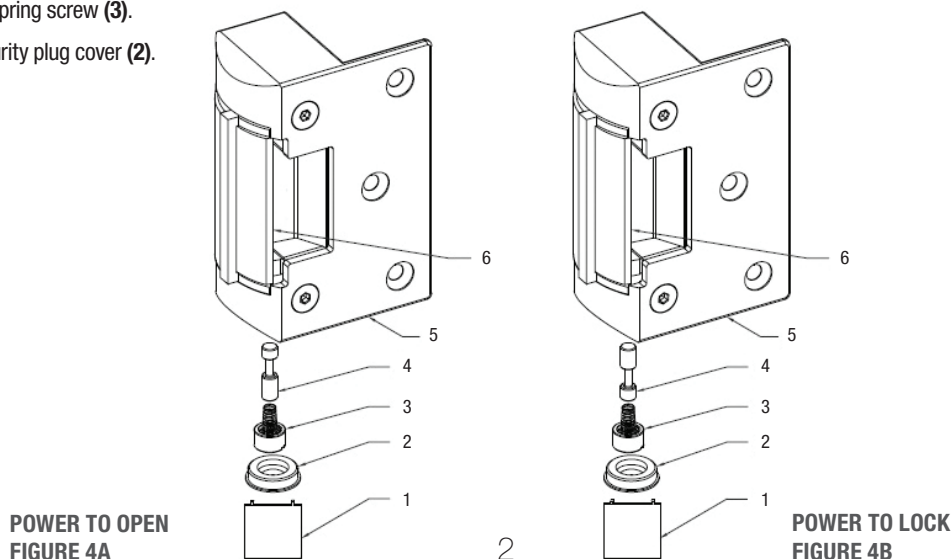

POWER TO OPEN
FIGURE 4A

POWER TO LOCK
FIGURE 4B