

Wall and Floor Mounted Hold Open Magnets



The Lockwood Padde Series EM830 Series of Hold Open Magnets can work as standalone or with an integrated fire system. These Fail-Safe devices will automatically release if connected to a fire detection system.

Some models include integrated "interrupter buttons" giving the ability to open or close the door manually at any time. Other models have an integrated soft close shock absorbers for silent operation i.e. in Hospitals

Key Features

- Fail Safe Operation – Unlocks when power is removed
- Shock absorber for soft close (model dependent)
- Integrated Interrupter push-button (model dependent)
- Modern Design
- Silent Operation (no humming)
- Easy Install
- Space bracket for wall mount option standard
- 5 Year Tricare Warranty (Padde Series)

Applications

Fire Doors that need to close upon fire signal

- Fire Doors
- Doors that restrict the passage of fire

Non Fire Doors that need to be held open

- Cinema Doors
- Hospital Doors
- Parameter Doors
- Other Doors

Hold open devices are primarily used for fire doors, but not only limited to this application. Other known applications are doors that require to be held open for several hours i.e. with Cabin Hooks. For this application the device needs constant power and no "smarts" are required.

Note: Ensure you select the model with Integrated Interrupter push-button and also buy 24vdc Power supply

Product Details

	EMHO830-1	EMHO830-2	EMHO830-3	EMHO830-4
Wall & Floor Mount	Yes	Yes	Yes	Yes
Integrated Interrupter pushbutton	No	Yes	No	Yes
Shock Absorber	No	No	Yes	Yes
Holding Force	150 kg	150 kg	150 kg	150 kg
Voltage	24vDC	24vDC	24vDC	24vDC
Operating Temperature	0-50°C	0-50°C	0-50°C	0-50°C
Floor Spacing	110 mm	110 mm	110 mm	110 mm
Wall Spacing	190 mm	190 mm	215 mm	215 mm
Continuous Duty	100%ED	100%ED	100%ED	100%ED

Standards and Compliance

CE CE Approved

 RCM Certified

IP 40 Rating

Wall and Floor Mounted Hold-Open Magnets



EMHO830-1



EMHO830-3

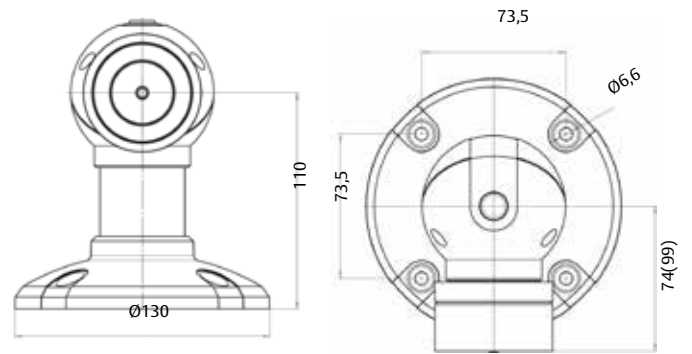

EM 830 Magnet Dimensions



EMHO830-2



EMHO830-4



EF800 Hold Bracket
(Ordered Separately)

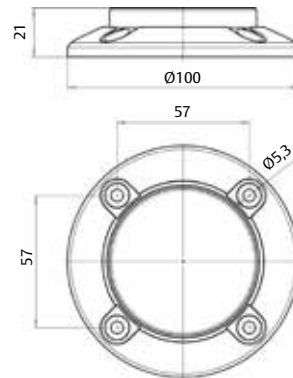

EF800 Hold Swivel Bracket
(Ordered Separately)

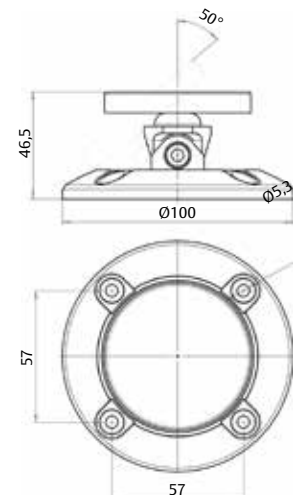

Wall and Floor Mounted Hold Open Magnets

Ordering Information

Part Number	Product Description
EMHO830-1	EM830 E/Hold Magnet 24Vdc
EMHO830-2	EM830 E/Hold Magnet 24Vdc Inter Button
EMHO830-3	EM830 E/Hold Magnet 24Vdc Shock Abs
EMHO830-4	EM830 E/Hold Magnet 24Vdc Shock Abs + Inter Button
EMHOB-1	EM800 Hold Open Bracket
EMHOB-2	EM800 Hold Open Swivel Bracket