

## EM4700 Monitored Weather Resistant 380kg Electro-Magnetic Lock Installation Manual

### Introduction:

The **EM4700** series electromagnetic lock is designed to be used on external gates or doors that are exposed to the elements. The casing is made of stainless steel and the product is rated to IP67. The **EM4700** can be installed on single swing doors or sliding doors and has no residual magnetism.

The electromagnetic lock should always be mounted on the secure side of the door. The EM4700 armature can be mounted from either the front, or the side.

The **EM4700** has a built-in power conditional relay switch. The functions are generated through three output wires as following:

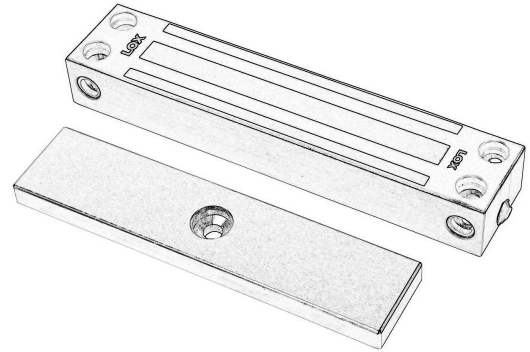

### Wiring and Power input requirements:

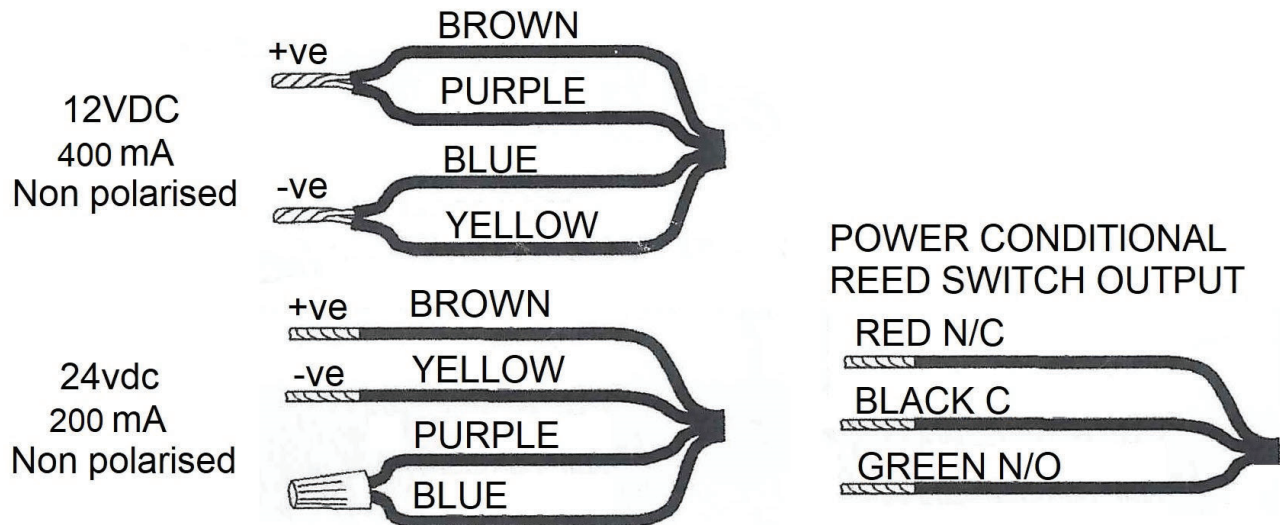

### Important Safety Requirements:

The armature plate must remain movable to allow surface alignment with the magnet face. The Magnetic Lock will lose holding force without this floating alignment.

**Do not trim the rubber washer mounted on the head of the armature centre bolt.**

Trimming rubber washers will adversely affect the release of the armature plate from the magnetic lock.

1. Apply thread-locker glue (i.g. Loctite) to the thread of the Armature-Plate-Fixing Screw (Allen-Screw) to prevent from becoming loose.
2. Locks have to be inspected at regular intervals to ascertain the safety functionality in conjunction with the door environment.
3. The supplied Allen screws cater for maximum door-thickness of 45mm.

## Trouble Shooting:

Problem	Possible Cause	Solution
Door will not lock	No DC voltage to lock.	Check power supply and wiring to magnetic lock.
Reduced holding force	No contact between armature plate and face of magnet.	Ensure mating surfaces are clean and in proper alignment and the armature plate floats freely.
	Low voltage or wrong voltage setting	Correct to specified voltage setting and power input requirement
Reed Switch Status is incorrect	Misalignment of armature plate.	Correct armature plate alignment.

### Maintenance:

Contacting surface of the Electro-Magnet and Armature Plate must be kept free of contaminating materials. Surfaces should be cleaned periodically with a non-abrasive cleaner. Do not spray the Electro-magnet or Armature Plate surface with any chemicals such as lacquer, etc. This will cause serious problems with the release of the magnetic Lock and its Armature Plate resulting in serious safety problems.

### Dimensions and Mounting Options:

