

WARNING

TO HELP PREVENT SERIOUS OR FATAL INJURIES FROM ENTRAPMENT OR FALLS :

* Stand No : SA/NZS 4220 : 2010

* Never allow child under 9 years on upper bunk.

* Use only mattress meeting the specification on the upper bunk :

<u>Bed type</u>	<u>Length</u>	<u>Width</u>
Standard length	1914 mm	934 mm

* Ensure thickness of mattress and foundation combined does not exceed 200mm (8") and mattress is at least 160mm below upper edge of guardrails .

* Guardrails must be attached on both side of upper bunk for strength and stability of bed.

* Prohibit horseplay on or under the bed(s) .

* Prohibit more than one person on upper bunk .

* Ladder must be used when entering and leaving upper bunk bed .

* Distributor's name : Salamander Enterprises Ltd

WARNING : TOP BUNKS AND ELEVATED BEDS ARE DANGEROUS

AND ARE NOT RECOMMENDED FOR CHILDREN UNDER THE AGE OF 9.

WARNING : TOP BUNKS ARE FOR USE BY CHILDREN UNDER 50 KG ONLY.

Falls from elevated beds can be fatal and deaths have occurred where children have fallen from elevated beds . This is relevant for all ages . The risk is greater for younger children .

The risk of injury or death from a fall from an elevated bed compared to a non - elevated bed is :

10 x greater for 7 - 8 years old

7 x greater for 9 - 10 years old

3 x greater for 11 - 12 years old

WARNING : The upper bunk bed must be more than 2 m from any ceiling fan .





ASSEMBLY INSTRUCTION

ASSEMBLY TIPS :

1. Remove hardware from box and sort by size.
2. Please check to see that all hardware and parts are present prior start of assembly .
3. Please follow attached instruction in the same sequence as numbered to assure fast and easy assembly.
4. Do not use power tools as they can over tighten and damage components.

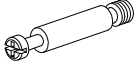
HARDWARE LIST

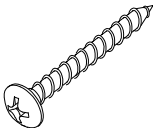
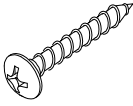
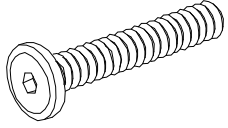
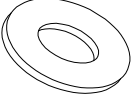
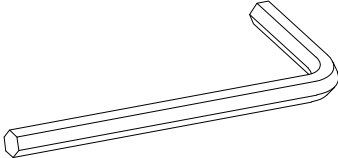
Component part and fittings contained in the box

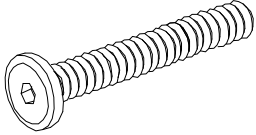
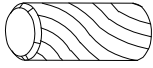
<p>H1 16pcs</p>  <p>Bolt</p>	<p>H2 16pcs</p>  <p>Cam Lock</p>	<p>H3 16pcs</p>  <p>Wooden dowel: Ø8x30(mm)</p>
<p>H4 24pcs</p>  <p>Screw: Ø4x30(mm)</p>	<p>H5 24pcs</p>  <p>Screw: Ø4x20(mm)</p>	<p>H6 8pcs</p>  <p>Hexagon screw: Ø6x30(mm)</p>
<p>H7 8pcs</p>  <p>Flat washer: Ø6</p>	<p>H8 1pc</p>  <p>Allen key 4 mm</p>	<p>H9 24pcs</p>  <p>White sticks</p>
<p>H10 4pcs</p>  <p>Hexagon screw: Ø6x40(mm)</p>	<p>H11 8pcs</p>  <p>Wooden dowel: Ø12x50(mm)</p>	

LIST DETAIL

Warning : Keep small components out of the reach of children !

P1 2pcs

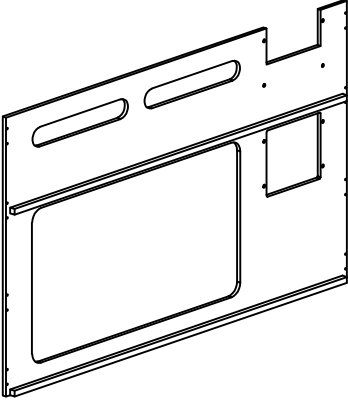

Side panel

P2 2pcs

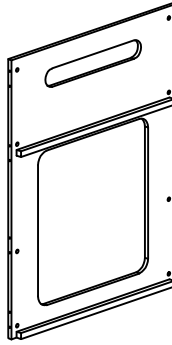

End panel

P3 2pcs

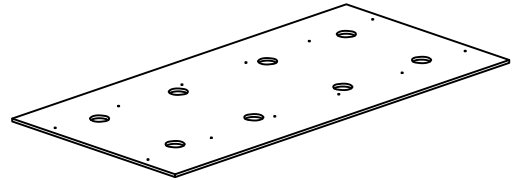

Bottom base panel

P4 1pc

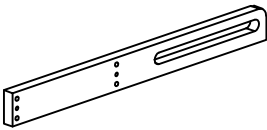

Left ladder

P5 1pc

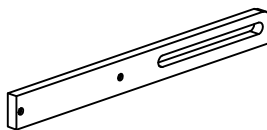

Right ladder

P6 1pc

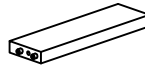

Ladder step 1

P7 1pc



Ladder step 2

P8 12pcs

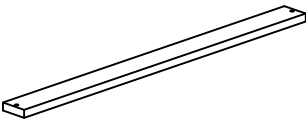

Slat

Step 1 :

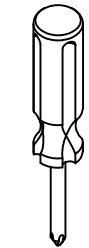
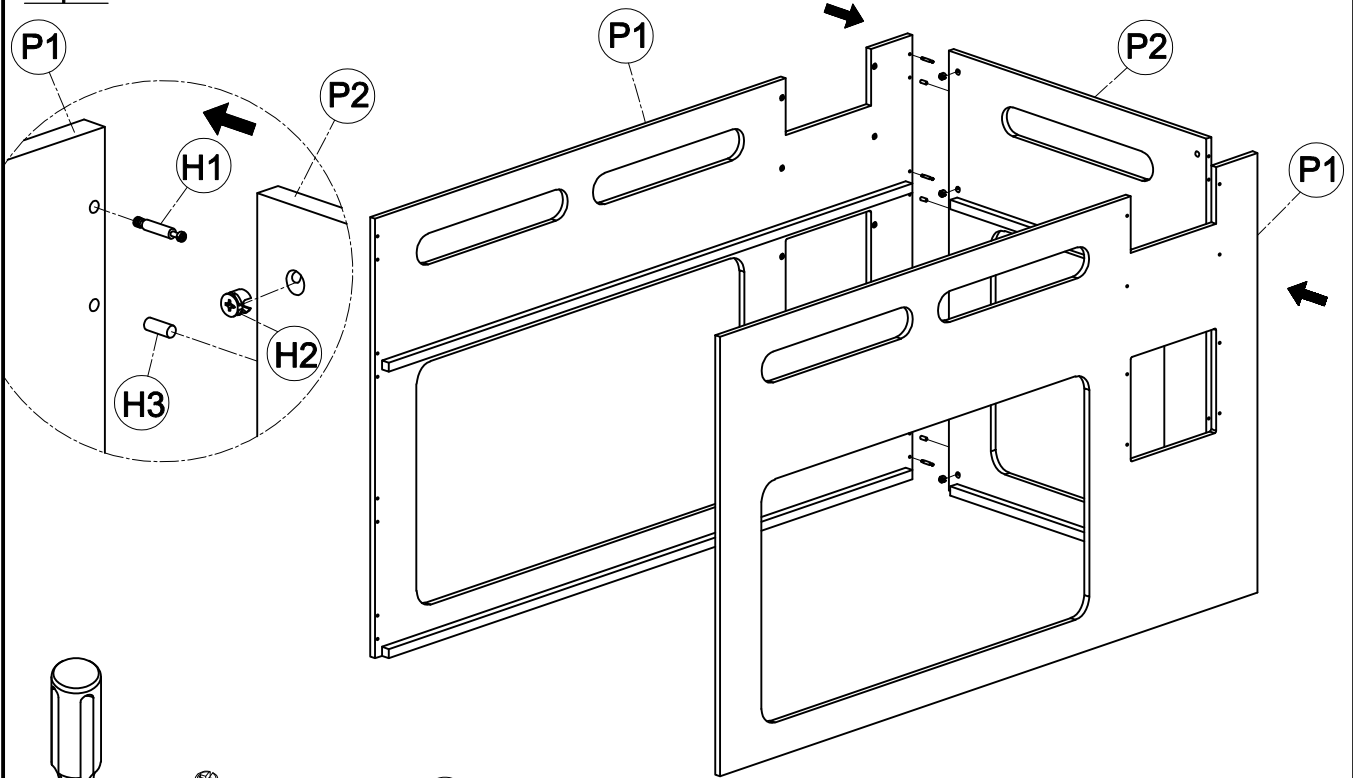

Screwdriver



H1



H2

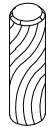

H3

- Construct 3 sides

- Press the wooden dowels (H3) into hole of (P2)

- Screw 8 pcs bolt (H1) into hole of (P1) by screwdriver

Step 2 :

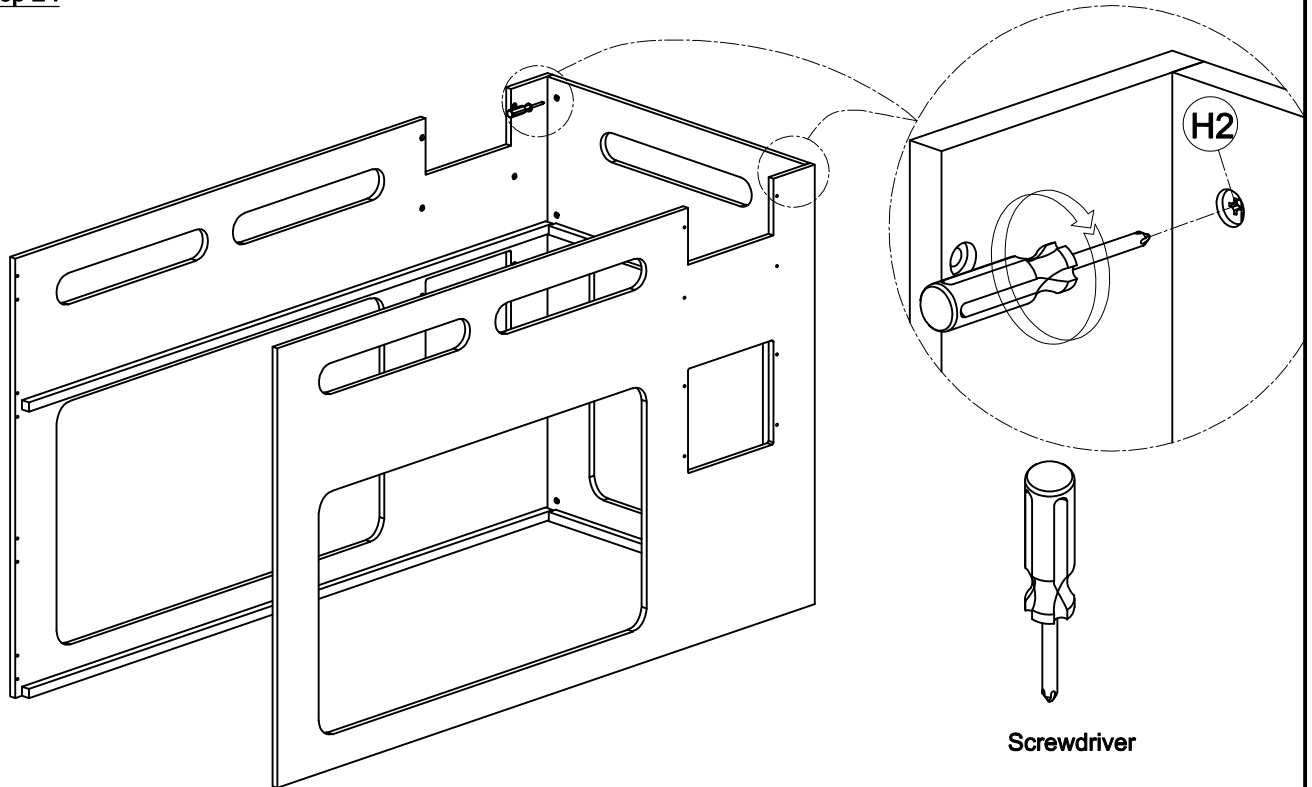

Screwdriver

- Tighten 8 pcs cam lock (H2) by screwdriver.

Step 3 :

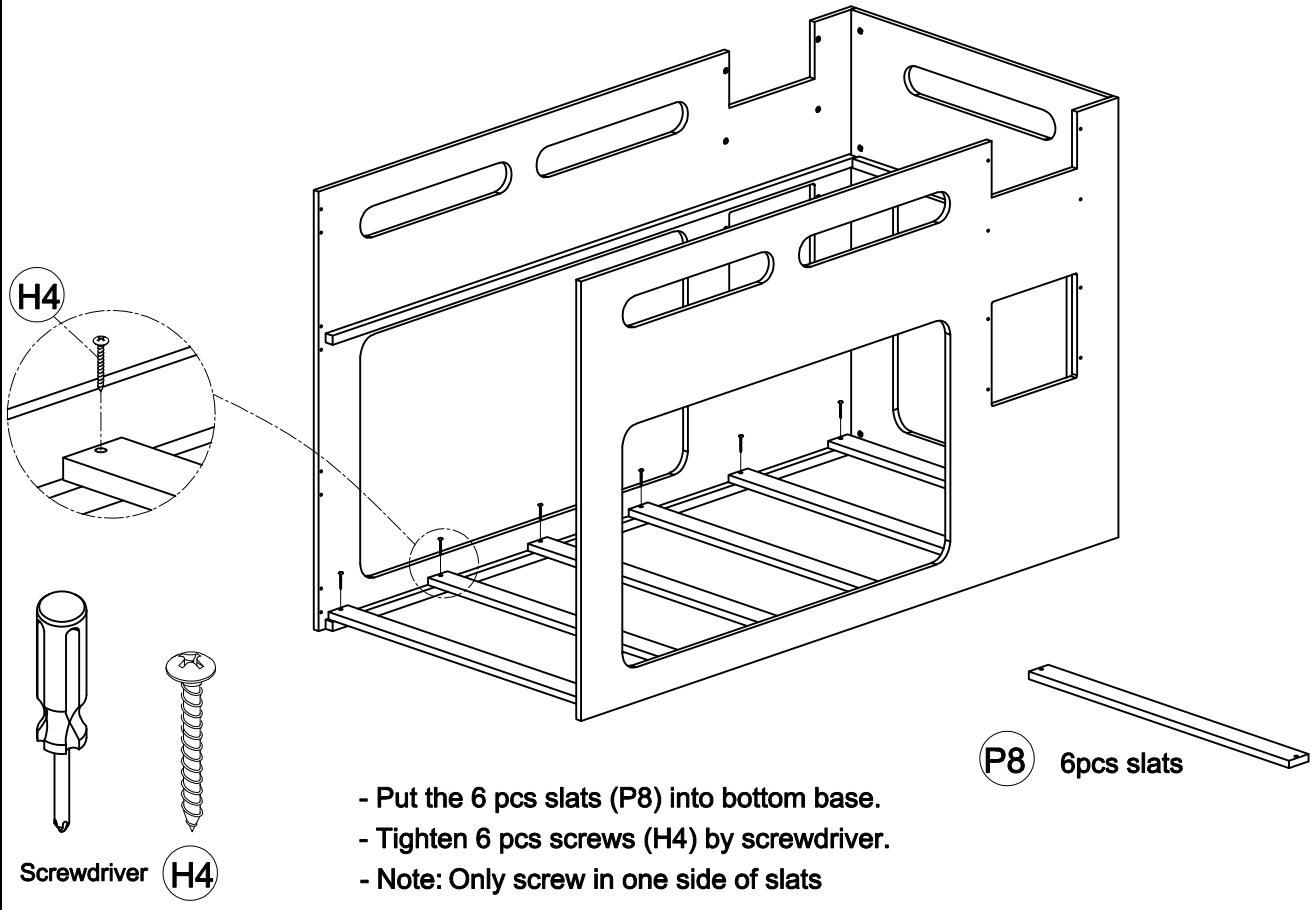

Step 4 :

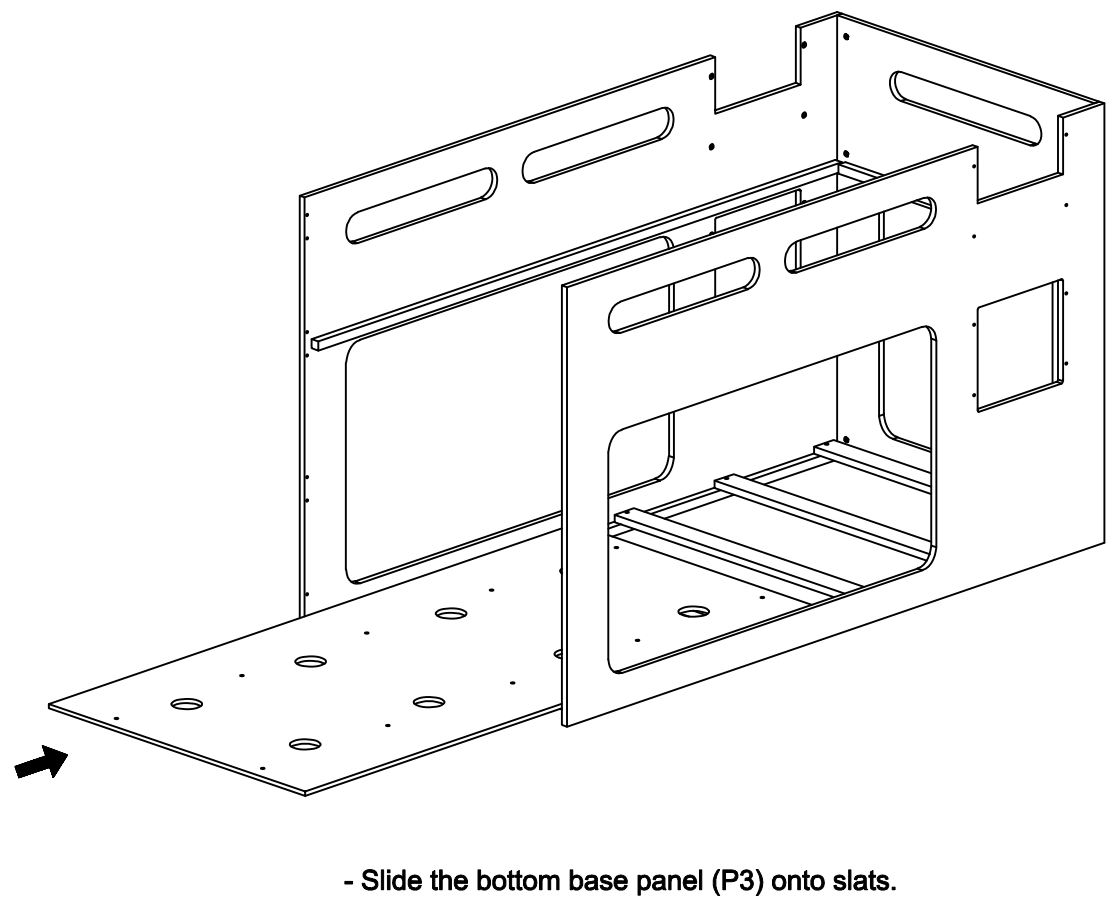

Step 5 :

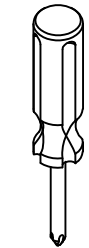
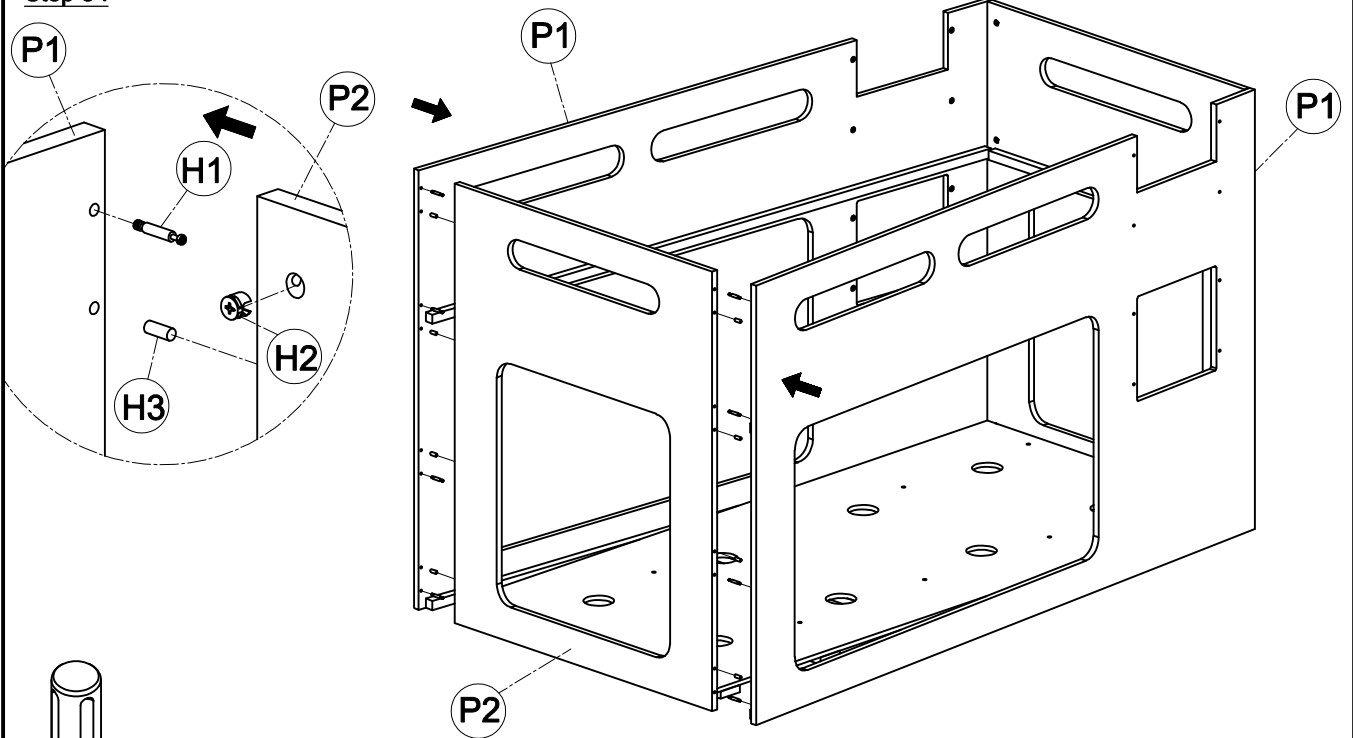

Screwdriver



H1



H2

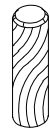

H3

- Attach final side
- Press the wooden dowels (H3) into hole of (P2)
- Screw 8 pcs bolt (H1) into hole of (P1) by screwdriver

Step 6 :

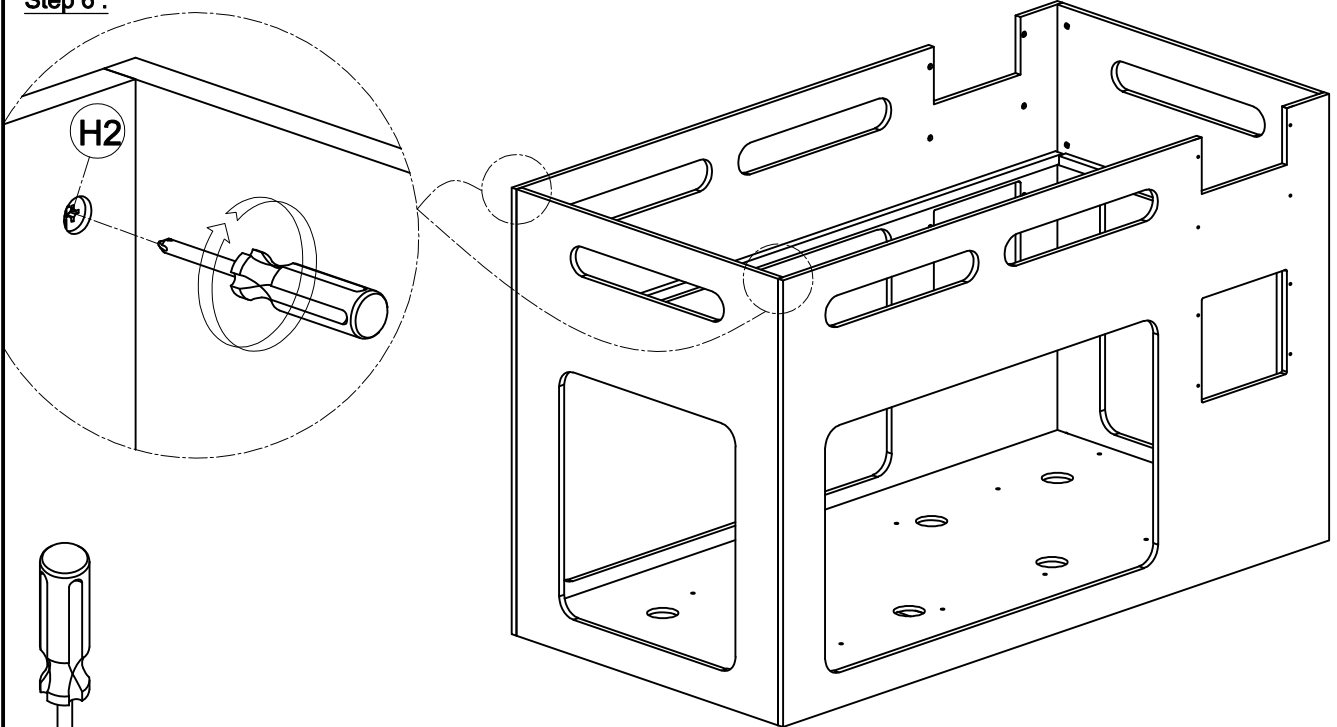

Screwdriver

- Tighten 8 pcs cam lock (H2) by screwdriver.

Step 7 :

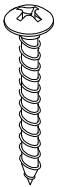
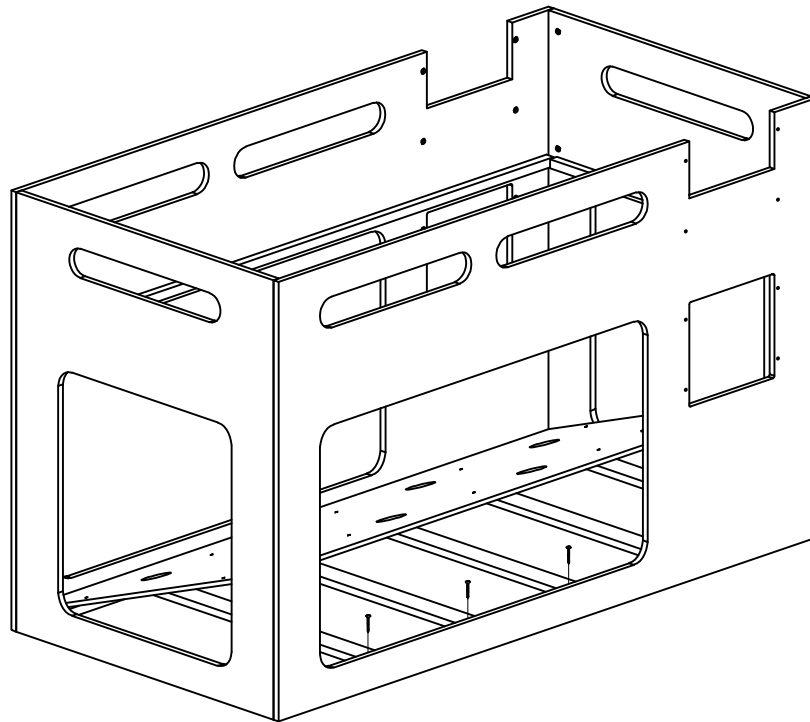

Screwdriver **H4**

- Pull up one side of base panel and screw in slats
- Tighten 6 pcs screws (H4) by screwdriver.

Step 8 :

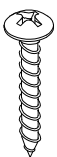
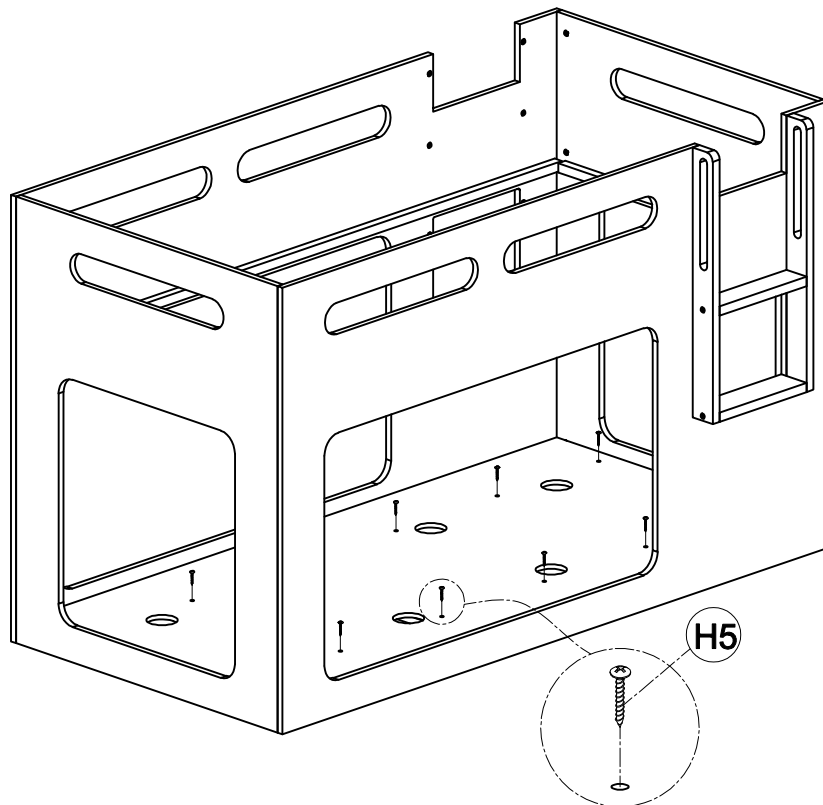

Screwdriver **H5**

- Tighten 12 pcs screws (H5) by screwdriver into slats.

Step 9 :

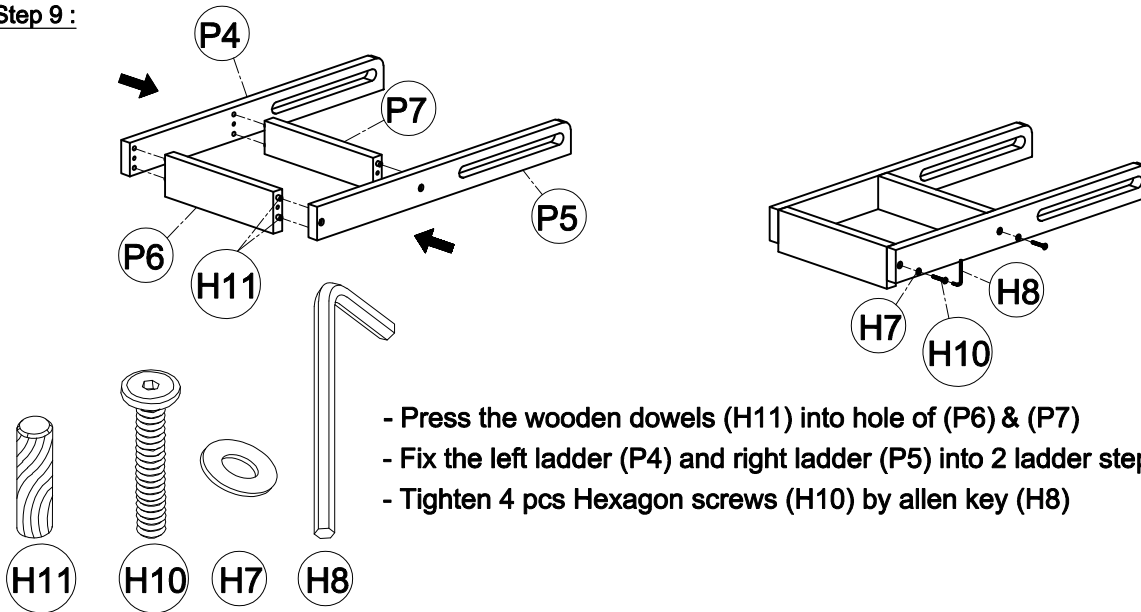

Step 10 :

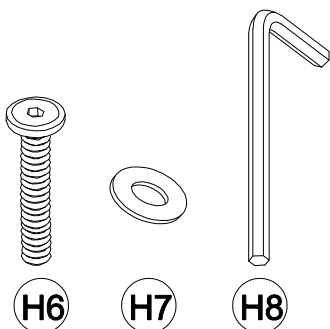
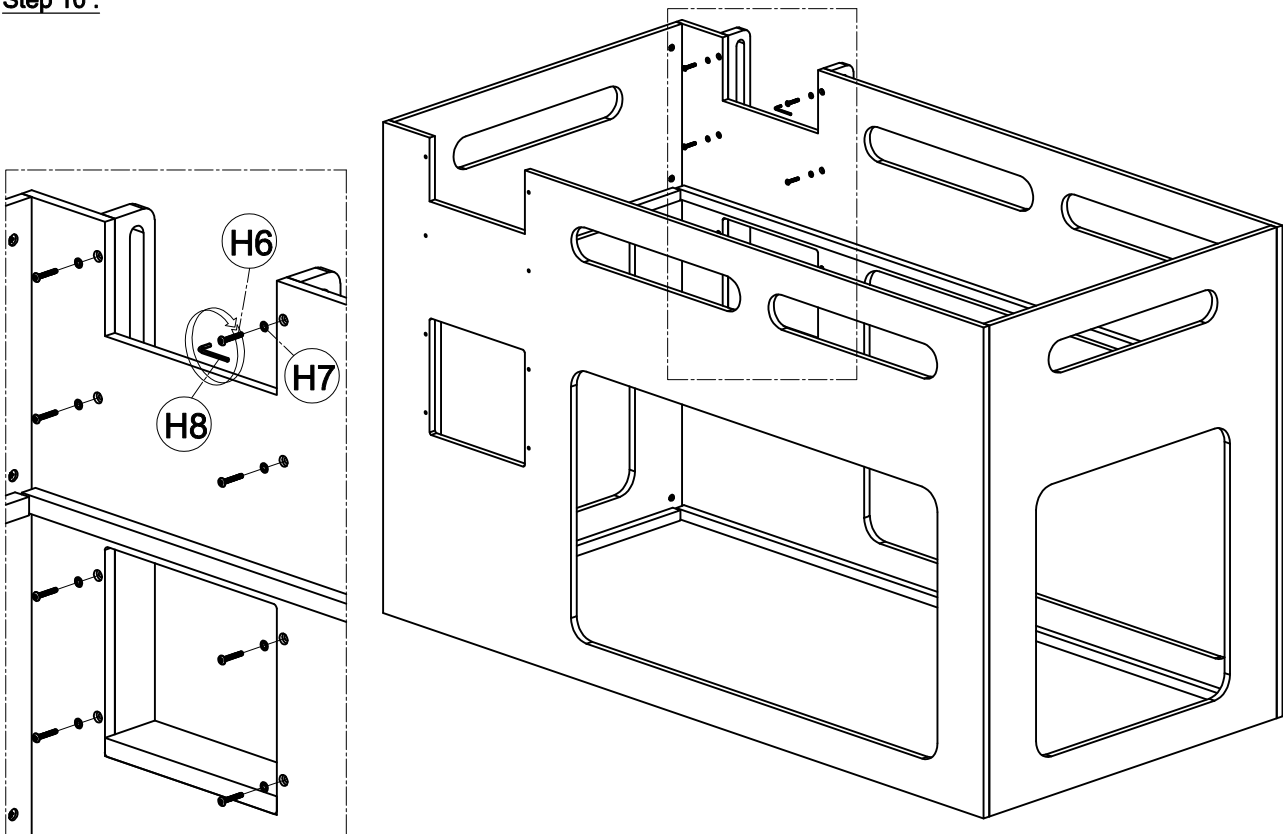

Step 11 :

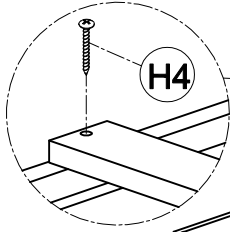

P8 6pcs slats

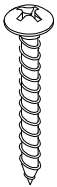
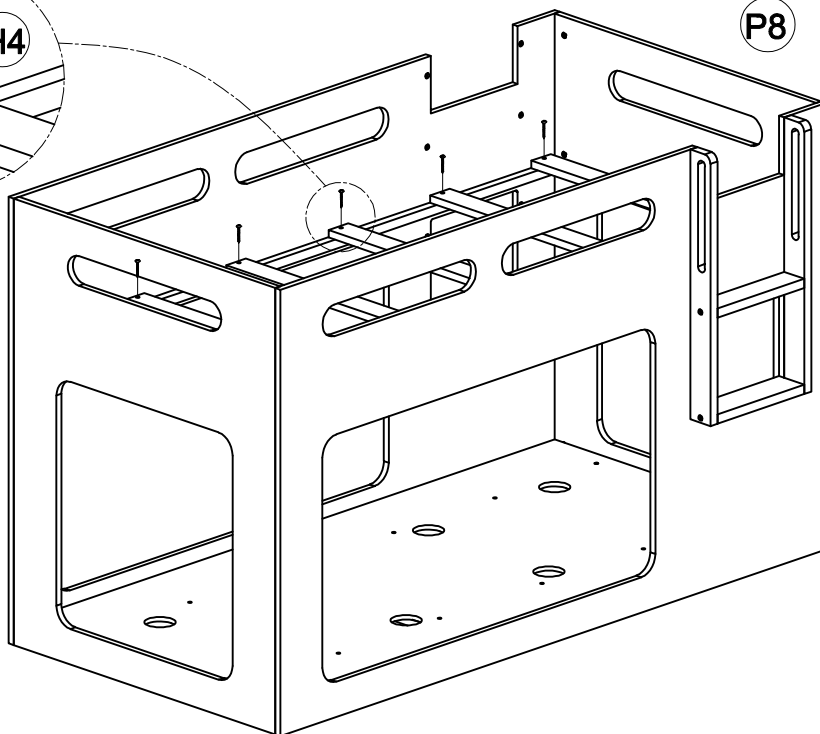

Screwdriver **H4**

- Put the 6 pcs slats (P8) onto upper bed.
- Tighten 12 pcs screws (H4) by screwdriver.

Step 12 :

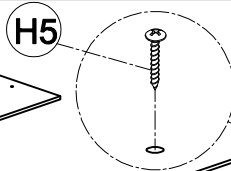

P3 1pc bottom base panel

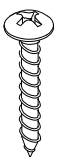
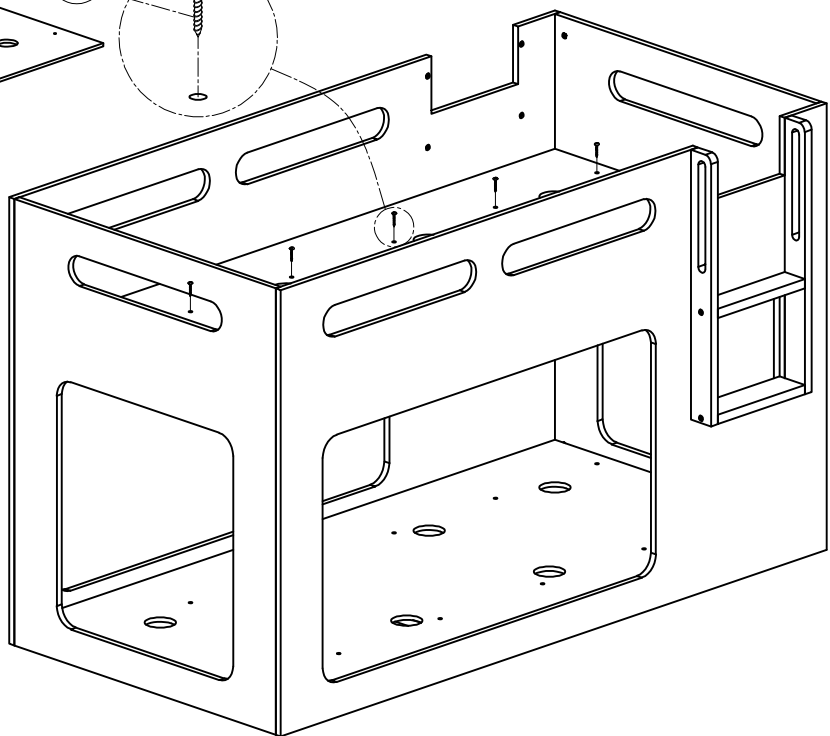
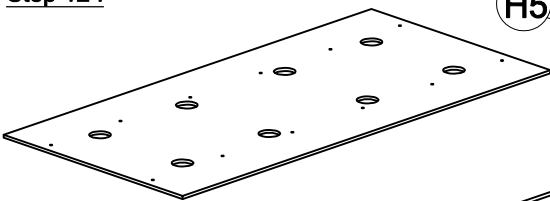

Screwdriver **H5**

- Put the base panel (P3) onto slats.
- Tighten 12 pcs screws (H5) by screwdriver into slats.

Step 13 :

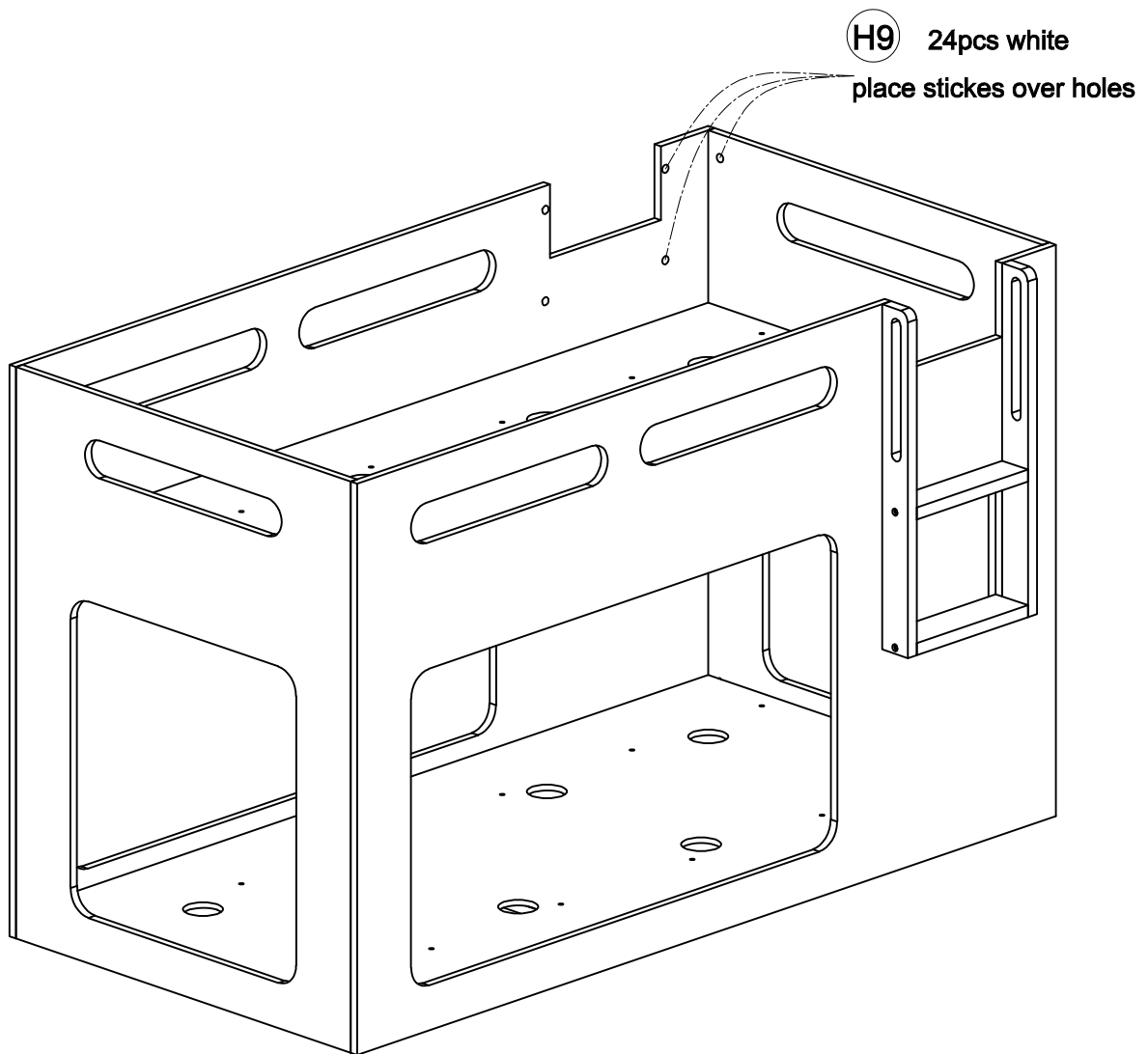

Finish