

ASSEMBLY INSTRUCTION

HARPER RD TABLE

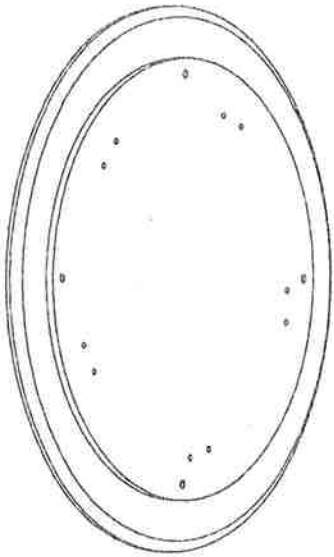

1

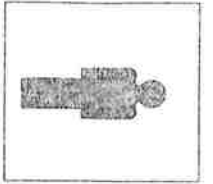
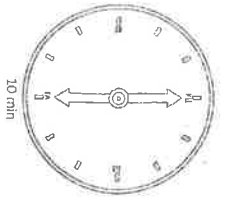
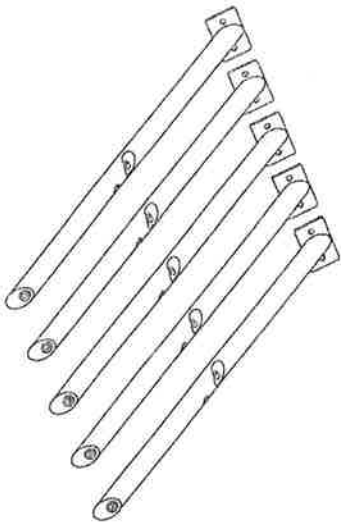

2

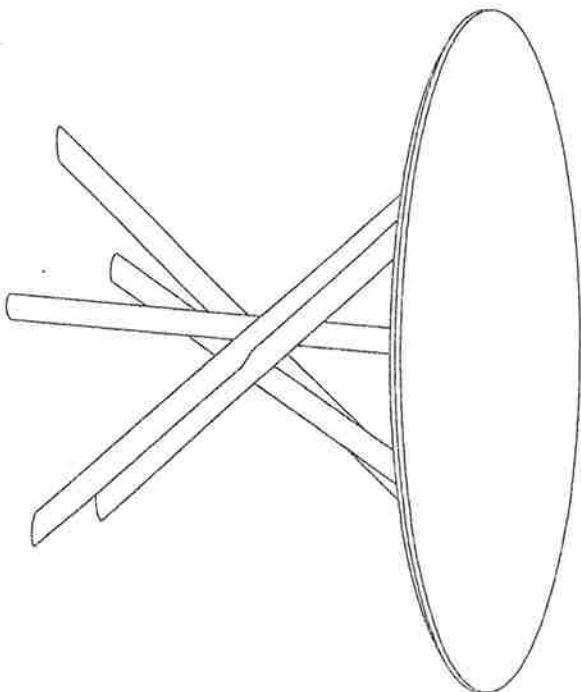

A x 10
M8 x 20



B x 5
M8 x 55



C x 1
M4

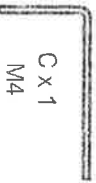

NOTE: All contents included with this item are listed below. Prior to assembly, identify and take inventory of the individual components and hardware listed. It is recommended that you place all contents on a padded or carpeted clean area during the assembly process to protect contents from damage. Closely follow all assembly instructions, step-by-step, as improper assembly can result in property or personal damage.

STEP 1:

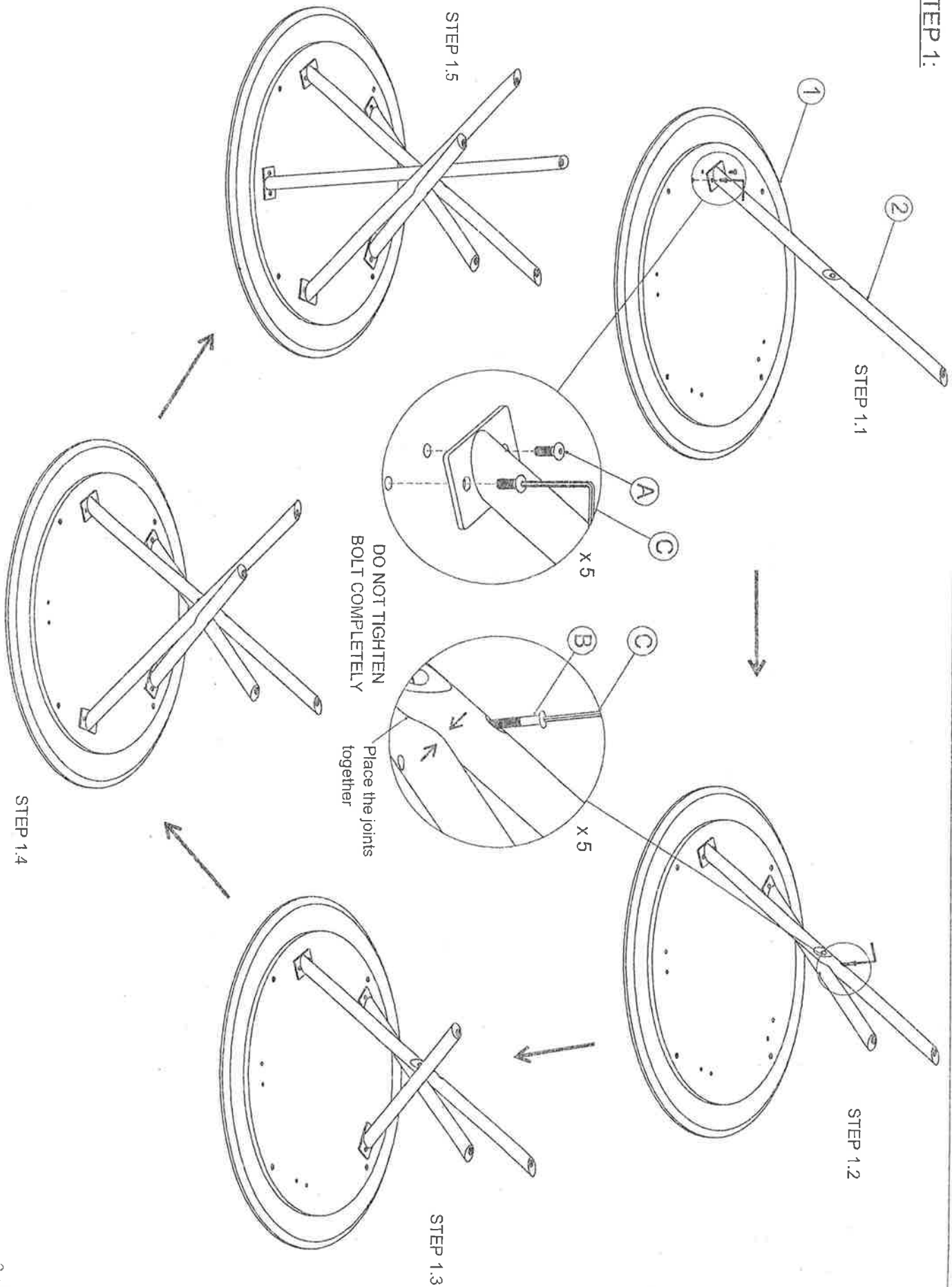

STEP 2:

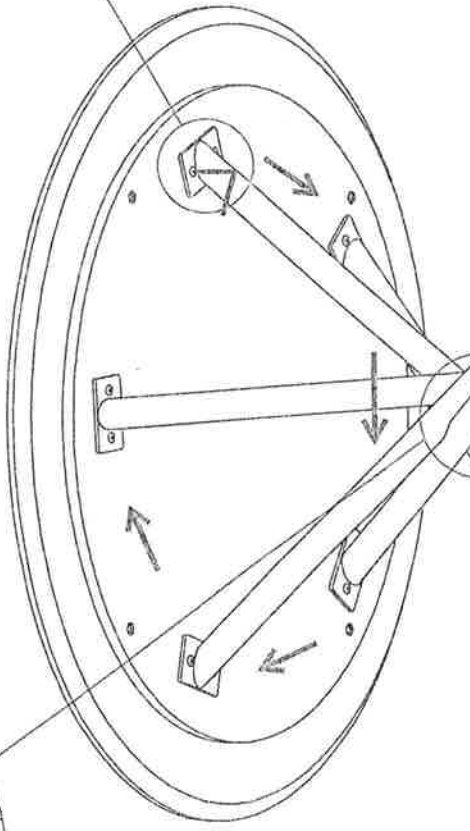
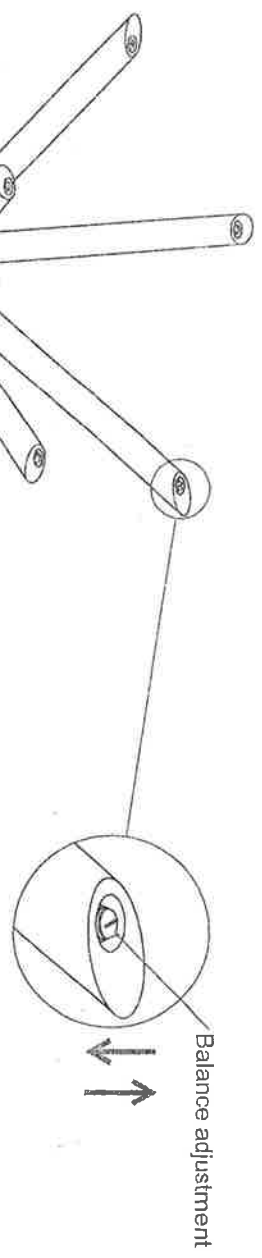

STEP 2.2

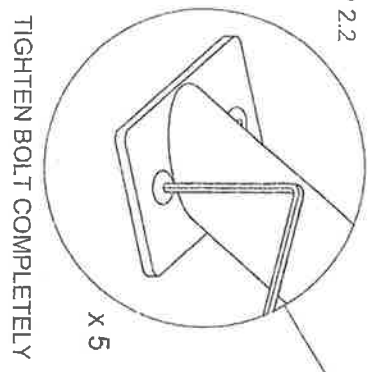

STEP 2.1

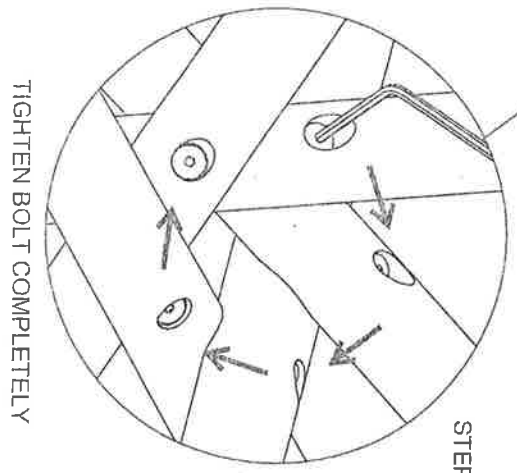

BE SURE TO CHECK ALL BOLTS SECURELY
TIGHTENED PRIOR USING THIS TABLE