

ASSEMBLY INSTRUCTION

MODEL : AVA BUNKS—SINGLE & KING SINGLE AS/NZS 4220:2010

DISTRIBUTING COMPANY LTD

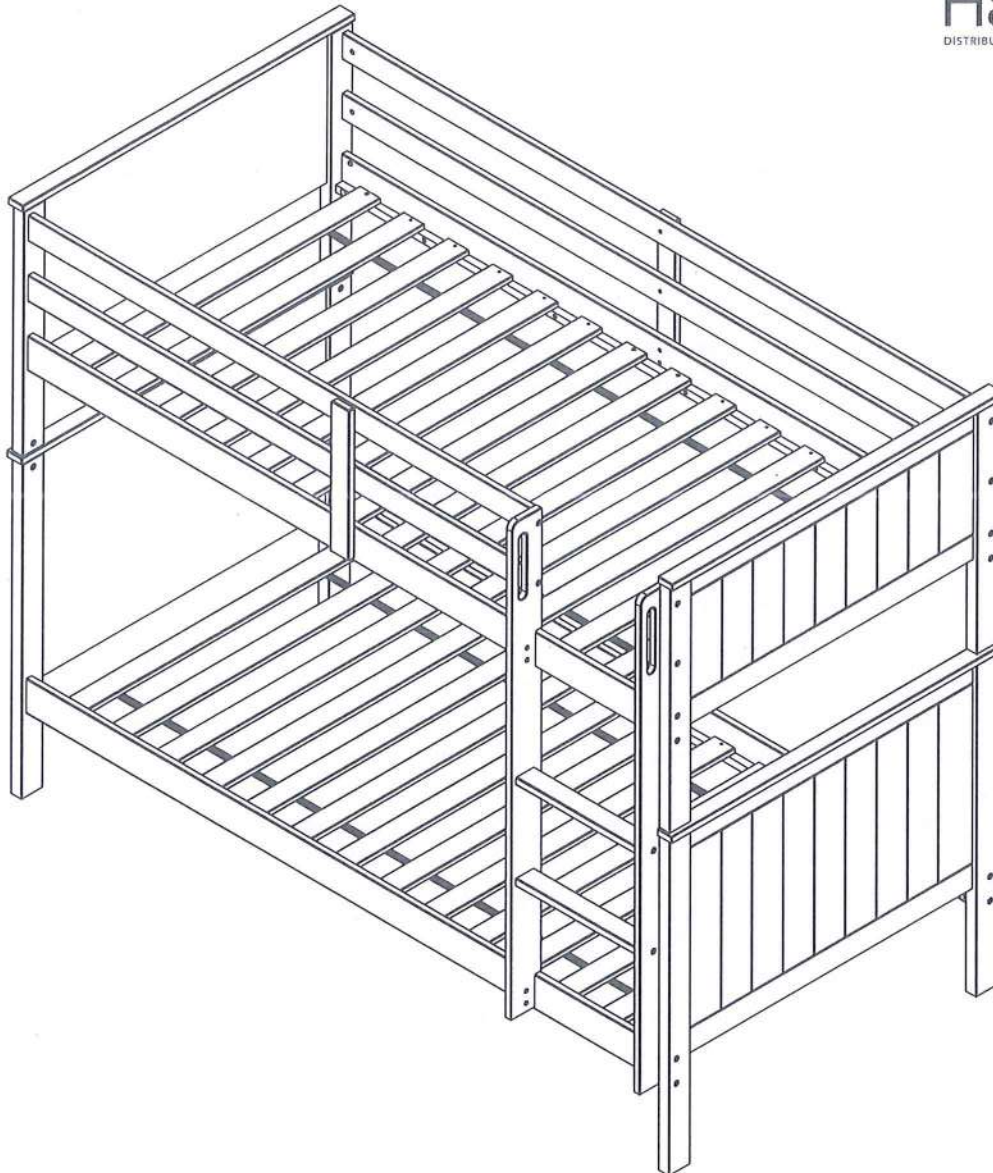

CARE & MAINTENANCE:

- Check all the components and fittings before start assembly.
- Assemble the item as close as possible to its final position (in the room of use).
- Assemble on a soft level surface to avoid damaging the unit or your floor.
- Assemble the parts will be easier with 2 persons.
- Periodically check all screws and fittings to ensure they are secure.
- The use of power drill is not recommended as this could damage the unit. Only use hand screwdrivers.
- DO NOT push the bed frame as this will damage the legs.
- Always lift the item with 2 persons to reposition.
- Keep any sharp objects away from the item.
- DO NOT drag objects across finished surfaces.
- Avoid placing your furniture in direct sunlight.
- Use clean, soft, dry, and lint-free cloth for the dusting process.

SAFETY WARNING & CAUTIONS:

To prevent serious or fatal injuries from entrapment or falls:

- Top bunks and elevated beds are dangerous to children under the age of 9 years.
 - o Falls from elevated beds can be fatal and deaths have occurred where children have fallen from elevated beds. This is relevant for all ages. The risk is greater for younger children.
 - o The risk of injury or death from a fall from an elevated bed compared to a non-elevated bed is:
 - 10 x greater for 7-8-year-olds.
 - 7 x greater for 9-10-year-olds.
 - 3 x greater for 11-12-year-olds.
 - Use guardrails on both sides of the upper bunk.
 - Use correct mattress size for the bunk size specification.
 - Sleep surface of upper mattress should be at least 160mm below the upper edge of the guardrail.
 - Prohibit horseplay on or under beds.
 - Always use ladder to enter and leave the upper bunk.
 - Check periodically to ensure the guardrail, ladder and other components are maintained in correct position and state of repair and that all connections are tight. Periodically tighten all bolts & screws to maintain tightness of bunk frame.
 - Do not place the bunk bed near an open window, to avoid injury.
- WARNING: The upper bunk must be more than 2 m from a ceiling fan.**

THIS BUNK IS COMPLIANCE TESTED AND CERTIFIED TO THE AUSTRALIAN / N.Z. STANDARD FOR BUNK BEDS AND OTHER ELEVATED BEDS-AS/NZS 4220:2010

Manufactured in Malaysia

Imported and distributed in NZ by Haven Distributing Co. Ltd.













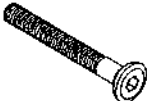

www.havennz.com

FINAL STEPS AFTER ASSEMBLY:

- Once all components are in place, ALL screws and bolts MUST be fully tightened BEFORE use of the bunk bed.
- ALL bolts & screws MUST be checked regularly and tightened to ensure the ongoing stability of the bunk bed.
- Keep these instructions for future use.

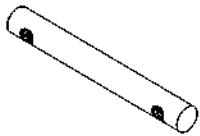
HARDWARE LIST (VP 384)

A 8 PCS  PLASTIC DOWEL (M8 x 30MM)	B 8 PCS  PLASTIC DOWEL (M10 x 35MM)	C 8 PCS  JCBC BOLT (M6 x 20MM)
D 2 PCS  JCBC BOLT (M6 x 40MM)	E 10 PCS  JCBC BOLT (M6 x 50MM)	F 22 PCS  JCBC BOLT (M6 x 70MM)
G 32 PCS  JRN NUT (M6 x 13MM)	H 2 PCS  JCN NUT (M6 x 12MM)	J 24 PCS  JCBC W SCREW (M7 x 32MM)
K 43 PCS  CSK C/B SCREW (M4 x 32MM)	L 4 PCS  METAL PIN WITH 2 HOLES (M10 x 80MM)	M 2 PCS  ALLEN KEY (M4 x 60MM)

- The assembly will require at least two people to complete.
- Make sure all the fasteners are tight.
- Due to the size of this bed, it must be assembled within the space it will occupy.
- Above all, take your time and read the instruction carefully.



Do not recommend the use of power drills/drivers for inserting bolts/screws as this could damage the unit.

Tools Required :
Crosshead Screw Driver

PART LIST

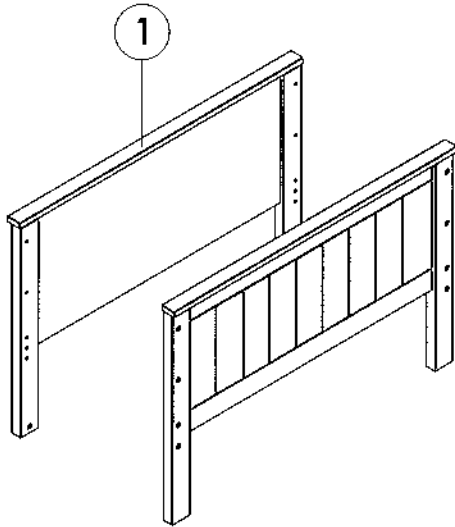

1

TOP HEADBOARD
(2 PCS / SET)
CARTON 1 OF 3

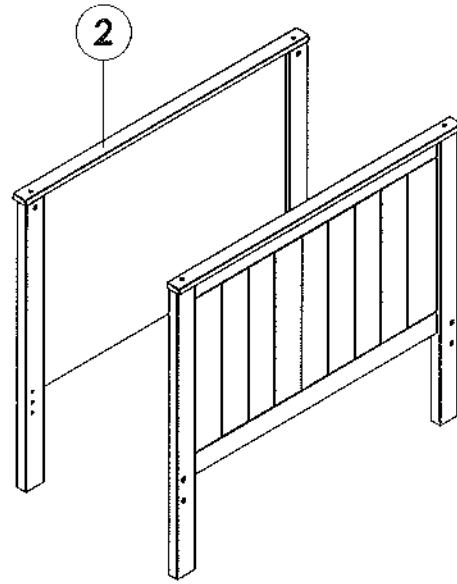

2

BOTTOM HEADBOARD
(2 PCS / SET)
CARTON 2 OF 3

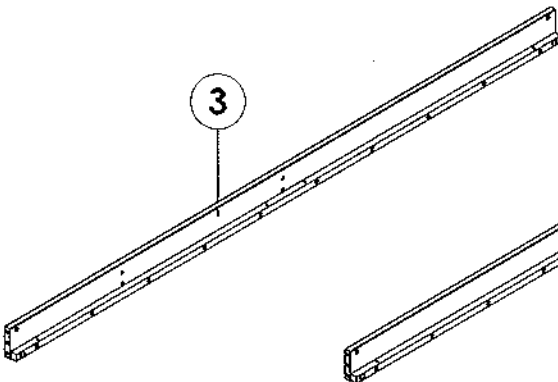

3

TOP SIDE RAIL (FRONT)
(1 PC / SET)
CARTON 3 OF 3

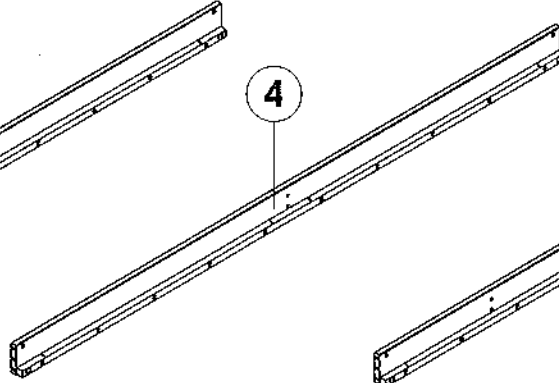

4

TOP SIDE RAIL (REAR)
(1 PC / SET)
CARTON 3 OF 3

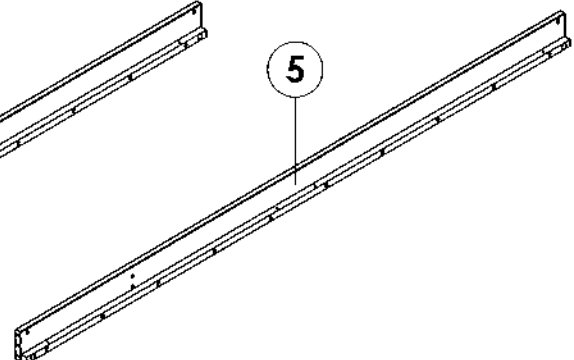

5

BOTTOM SIDE RAIL (FRONT)
(1 PC / SET)
CARTON 3 OF 3

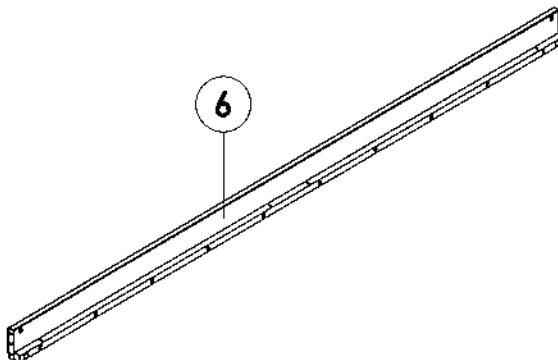

6

BOTTOM SIDE RAIL (REAR)
(1 PC / SET)
CARTON 3 OF 3

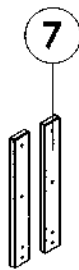

7

GUARD RAIL SUPPORT
(2 PCS / SET)
CARTON 3 OF 3

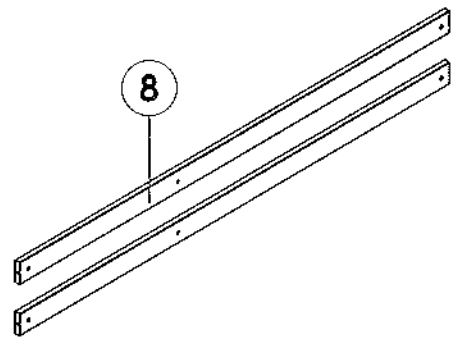

8

SEMI GUARD RAIL
(2 PCS / SET)
CARTON 3 OF 3

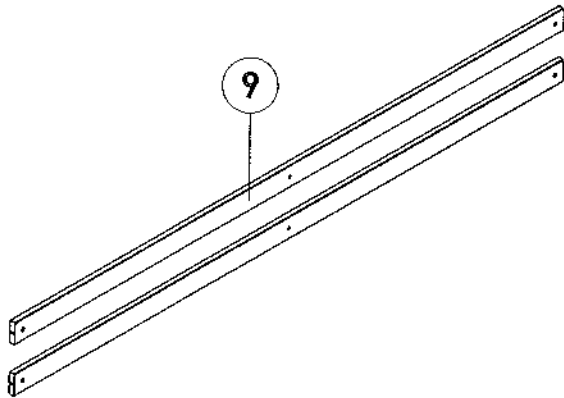

FULL GUARD RAIL
(2 PCS / SET)
CARTON 3 OF 3

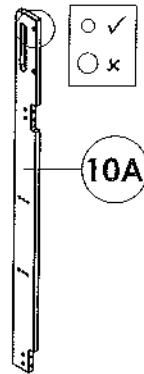

LADDER SIDE (GUARD RAIL)
(1 PC / SET)
CARTON 3 OF 3

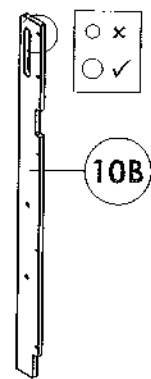

LADDER SIDE (POST)
(1 PC / SET)
CARTON 3 OF 3

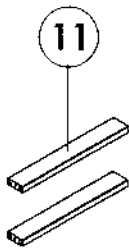

LADDER SLAT
(2 PCS / SET)
CARTON 3 OF 3

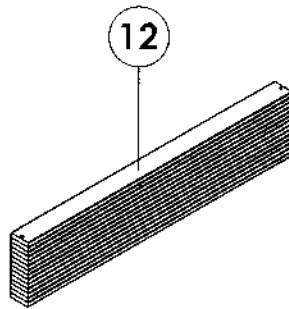

WOODEN SLAT
(14 PCS / SET) (SINGLE)
CARTON 1 OF 3

(15 PCS / SET - KING SINGLE)

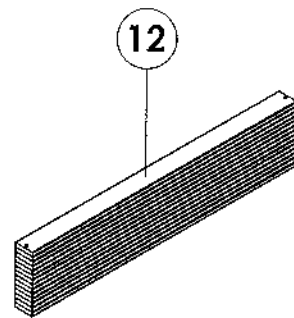

WOODEN SLAT
(14 PCS / SET) (SINGLE)
CARTON 2 OF 3

(15 PCS / SET - KING SINGLE)

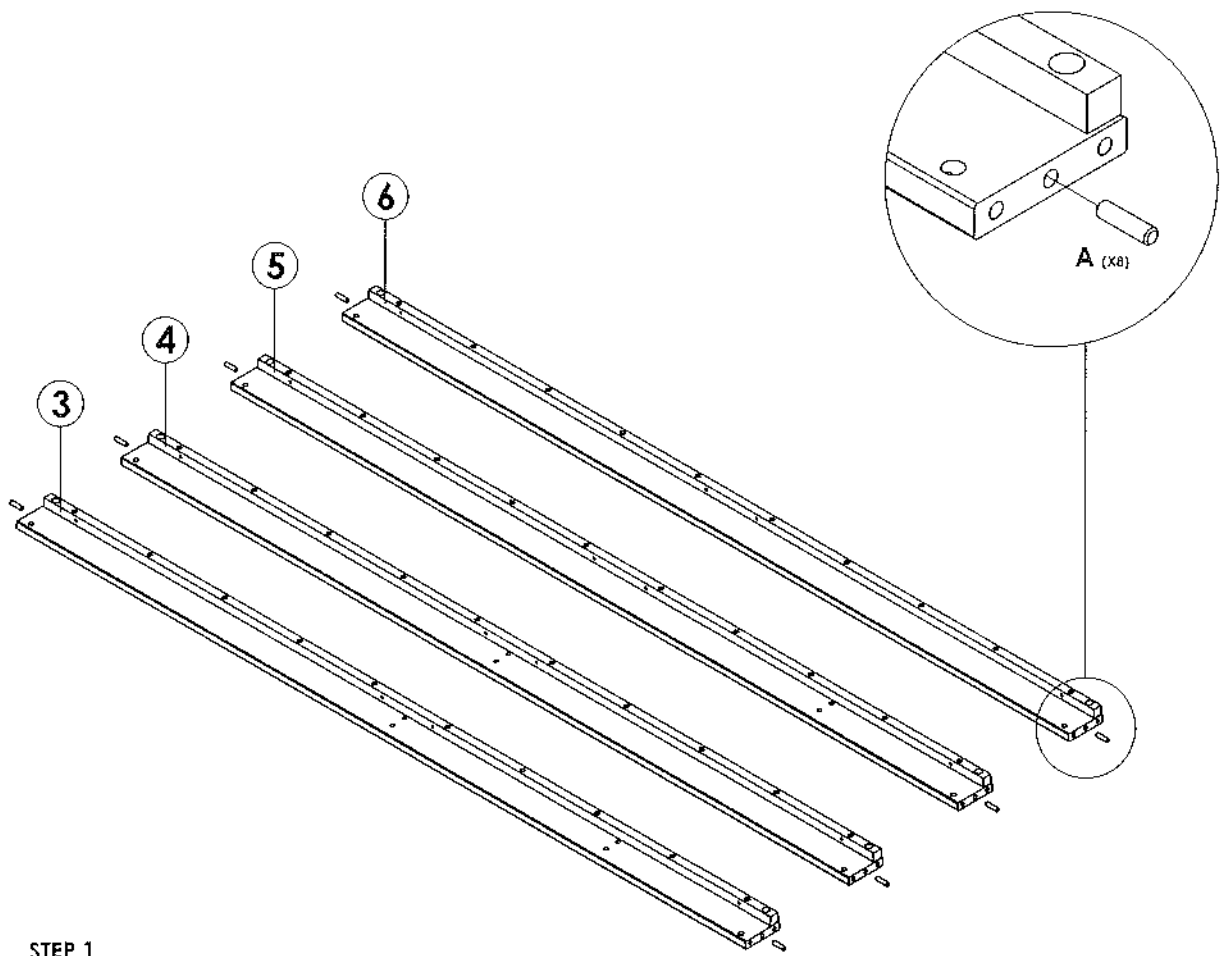

STEP 1

Insert (A) into Ø8MM holes on Top Side Rail (Front) & (Rear),
Bottom Side Rail (Front) & (Rear).

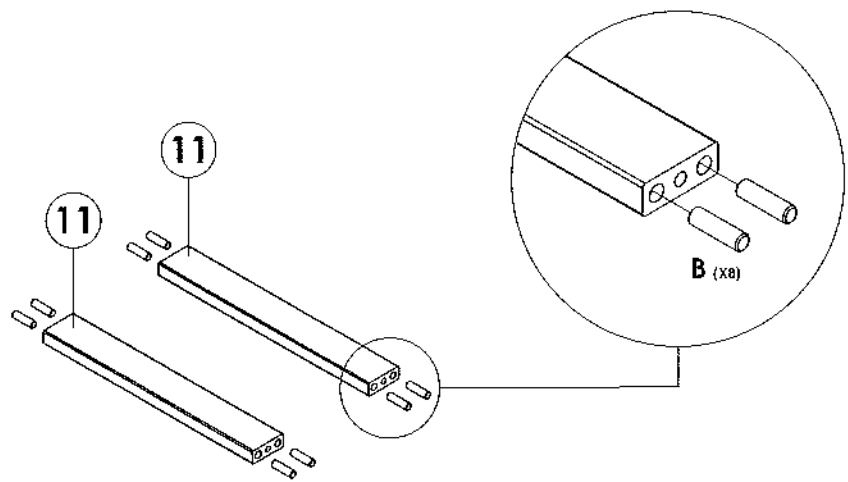

STEP 2

Insert (B) into Ø10MM holes on Ladder Slot.

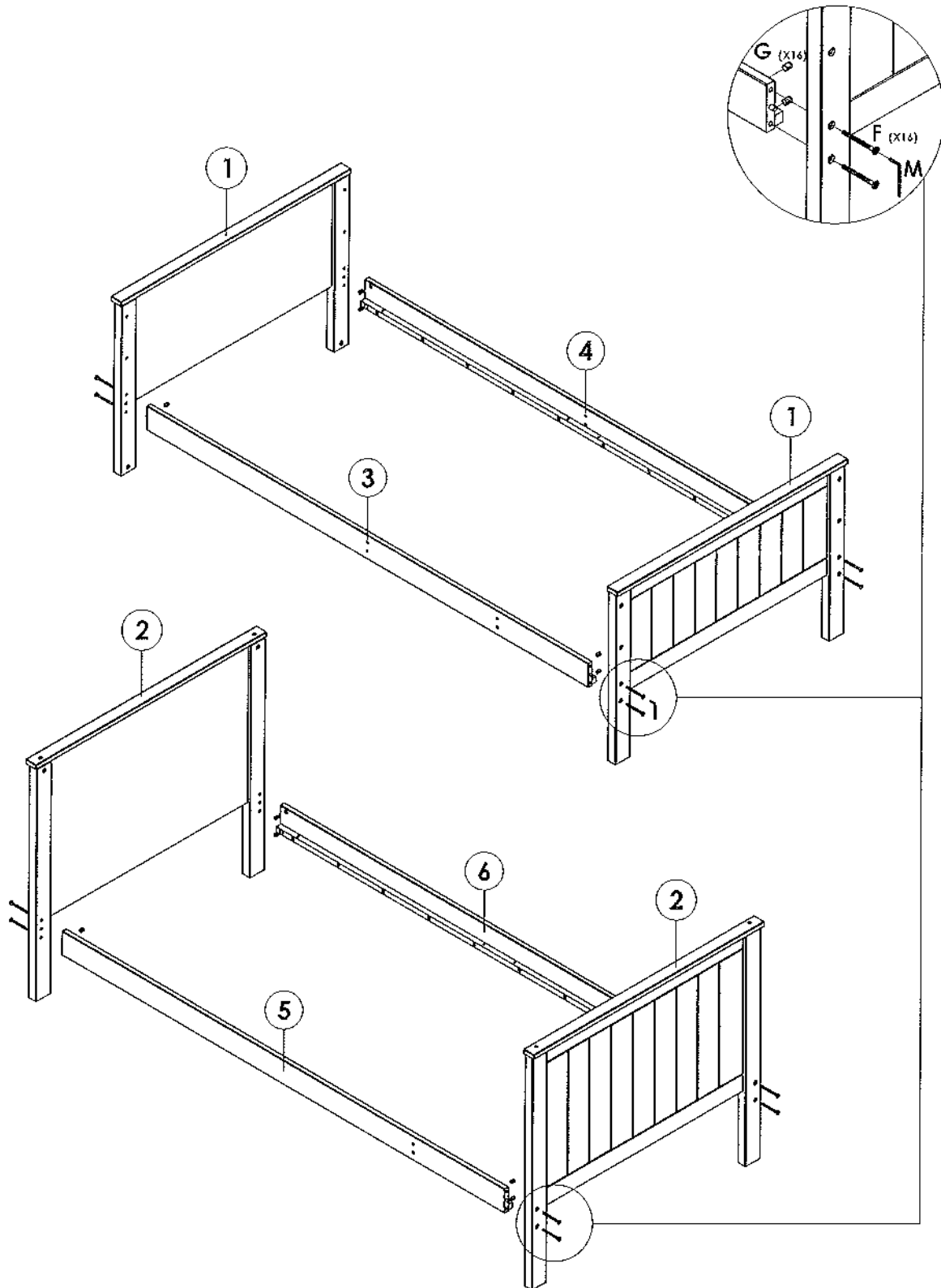

STEP 3

Attach and secure **Top Side Rail (Front)** and **Top Side Rail (Rear)** onto **Top Headboard** by using (F) and (G), tighten it by using (M).

Attach and secure **Bottom Side Rail (Front)** and **Bottom Side Rail (Rear)** onto **Bottom Headboard** by using (F) and (G), tighten it by using (M).

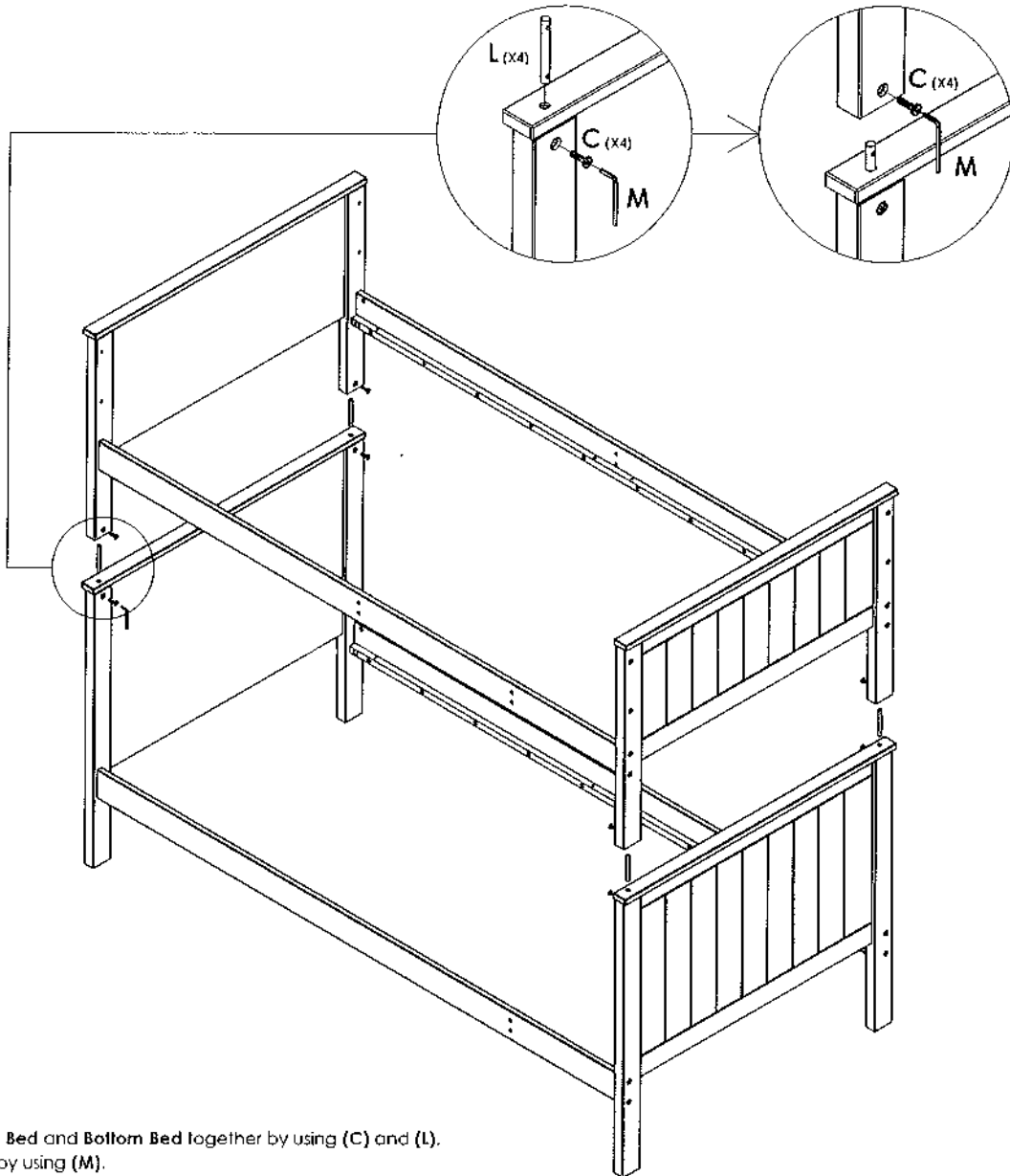

STEP 4

Connect **Top Bed** and **Bottom Bed** together by using (C) and (L),
tighten it up by using (M).

**Please make sure the both Side Rail (Front) is facing outwards while doing this assembly.*

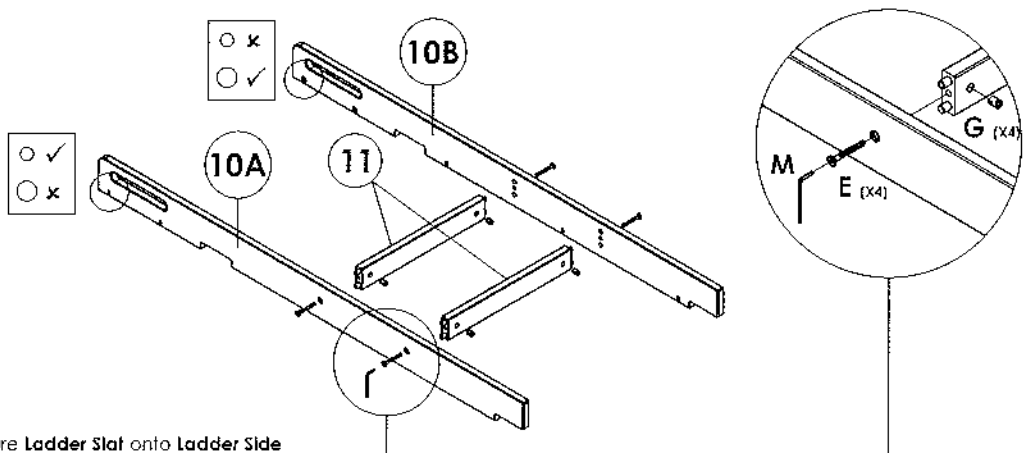

STEP 5

Attach and secure **Ladder Slat** onto **Ladder Side**
by using (E) and (G), tighten it up by using (M).

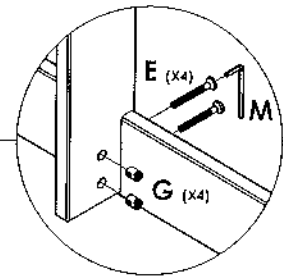
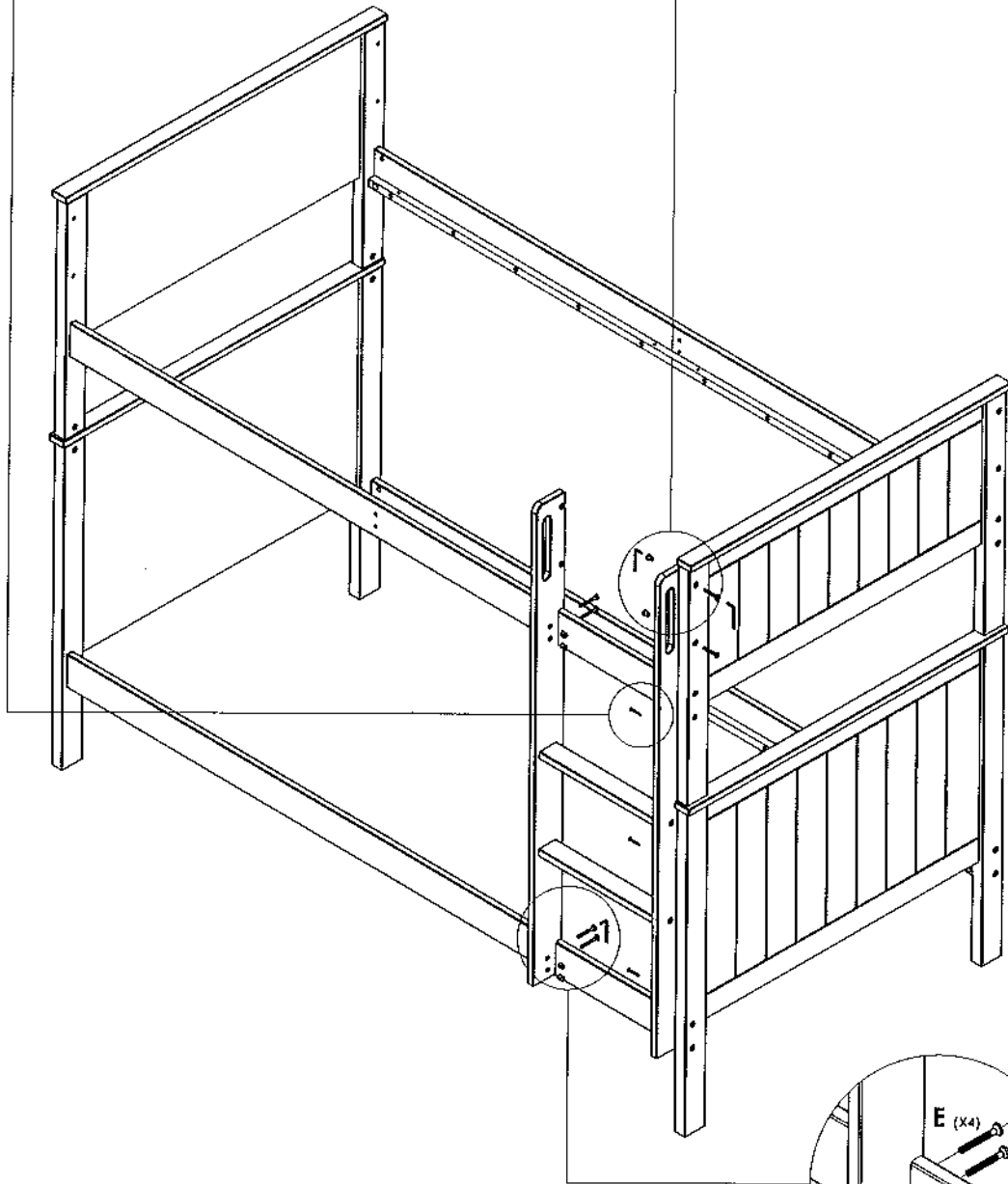
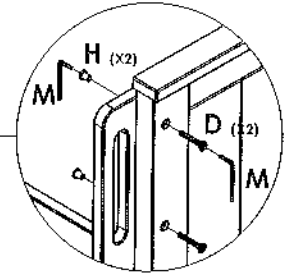
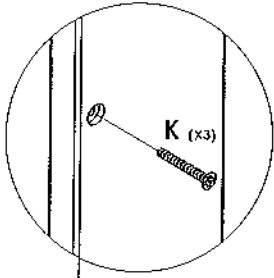

STEP 6

Attach and Secure **Ladder** by using **(K)**, tighten it up by using a Crosshead Screw Driver.

Attach and secure **Ladder** onto the **Top Headboard** by using **(D)** and **(H)**, tighten it up by using **(M)**.

Attach and secure **Ladder** to **Top Side Rail (Front)** and **Bottom Side Rail (Front)** by using **(E)** and **(G)**, tighten it up by using **(M)**.

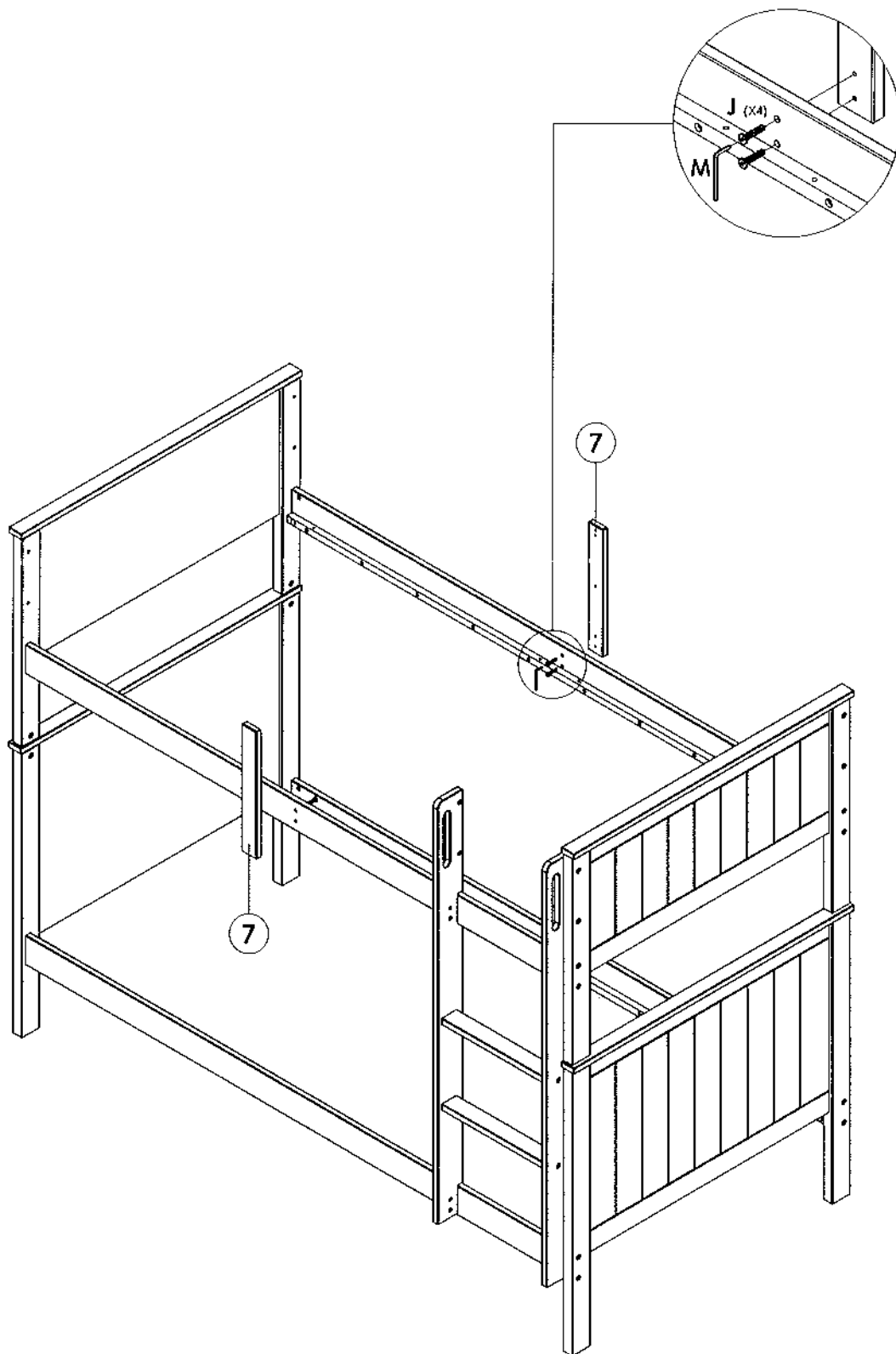

STEP 7

Attach and secure **Guard Rail Support** onto **Semi Guard Rail** and **Full Guard Rail** by using **(J)**, tighten it up by using **(M)**.

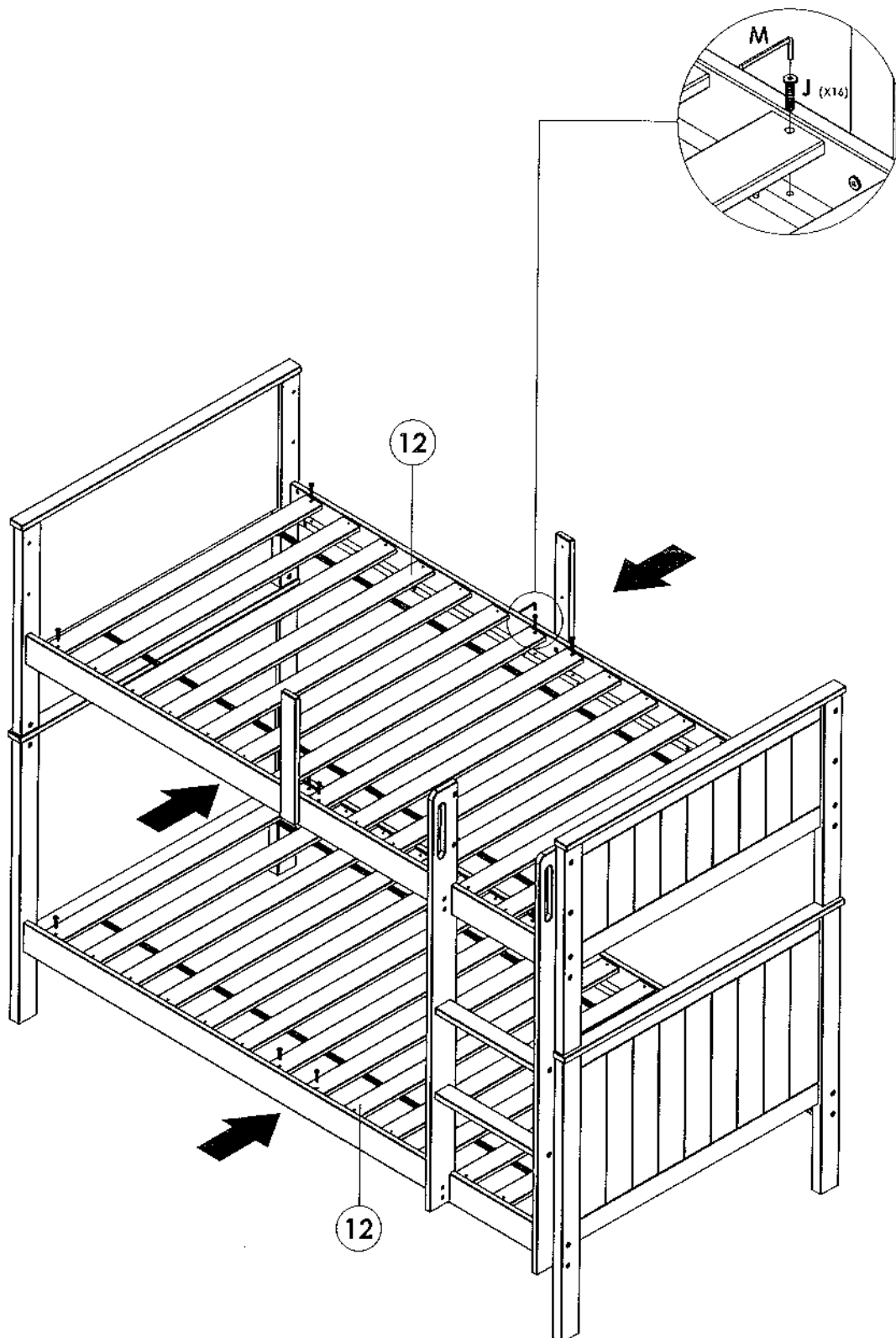

STEP 8

Attach and Secure all the Wooden Slat onto Side Rail by using (J), tighten it up by using (M).

* Align both Side Rail before tightening the screws.

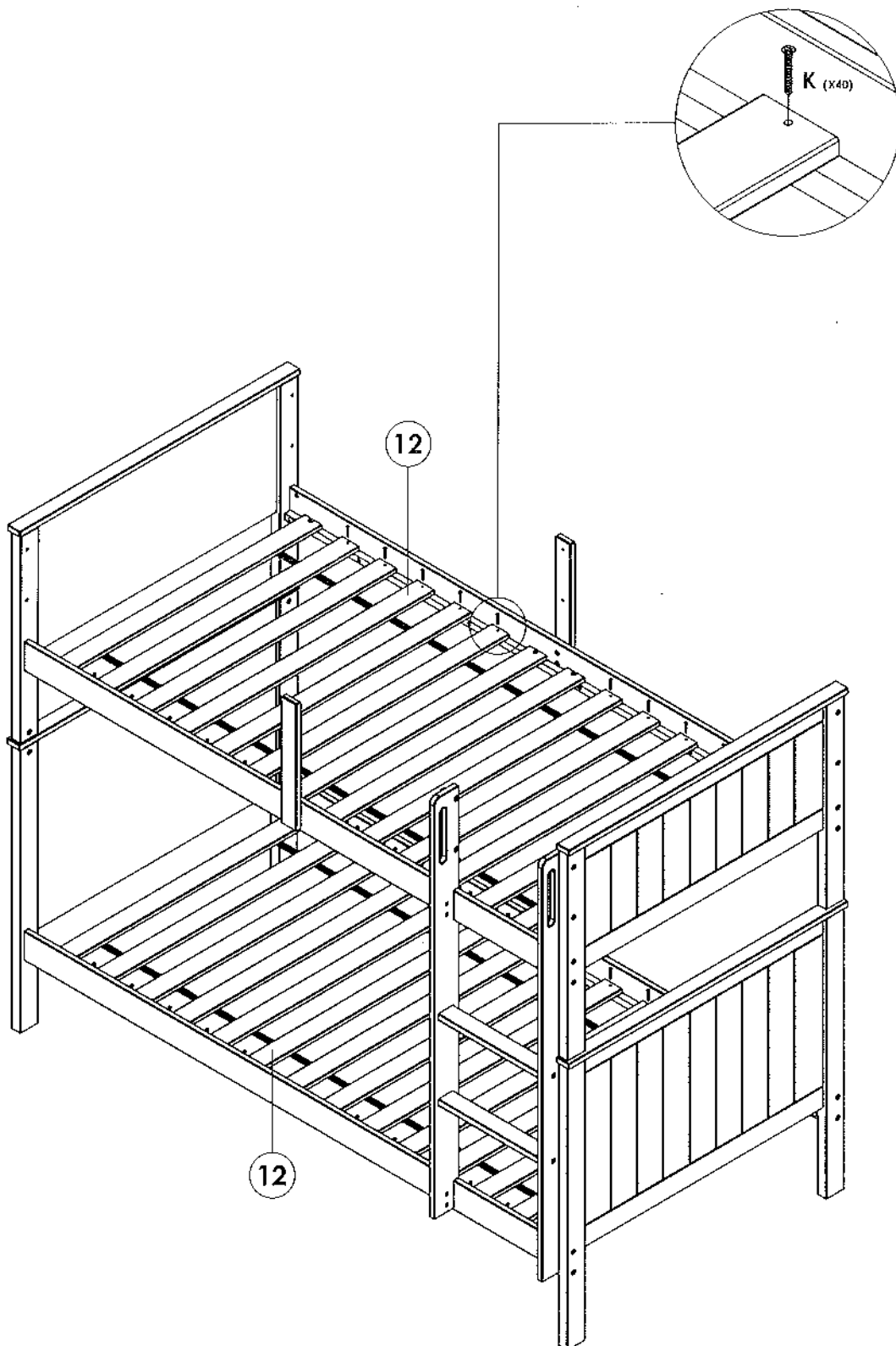

STEP 9

Continue to tighten it up the next of the slat by using (K), tighten it up by using a Crosshead Screw Driver.

* Tighten the rest of the screw.

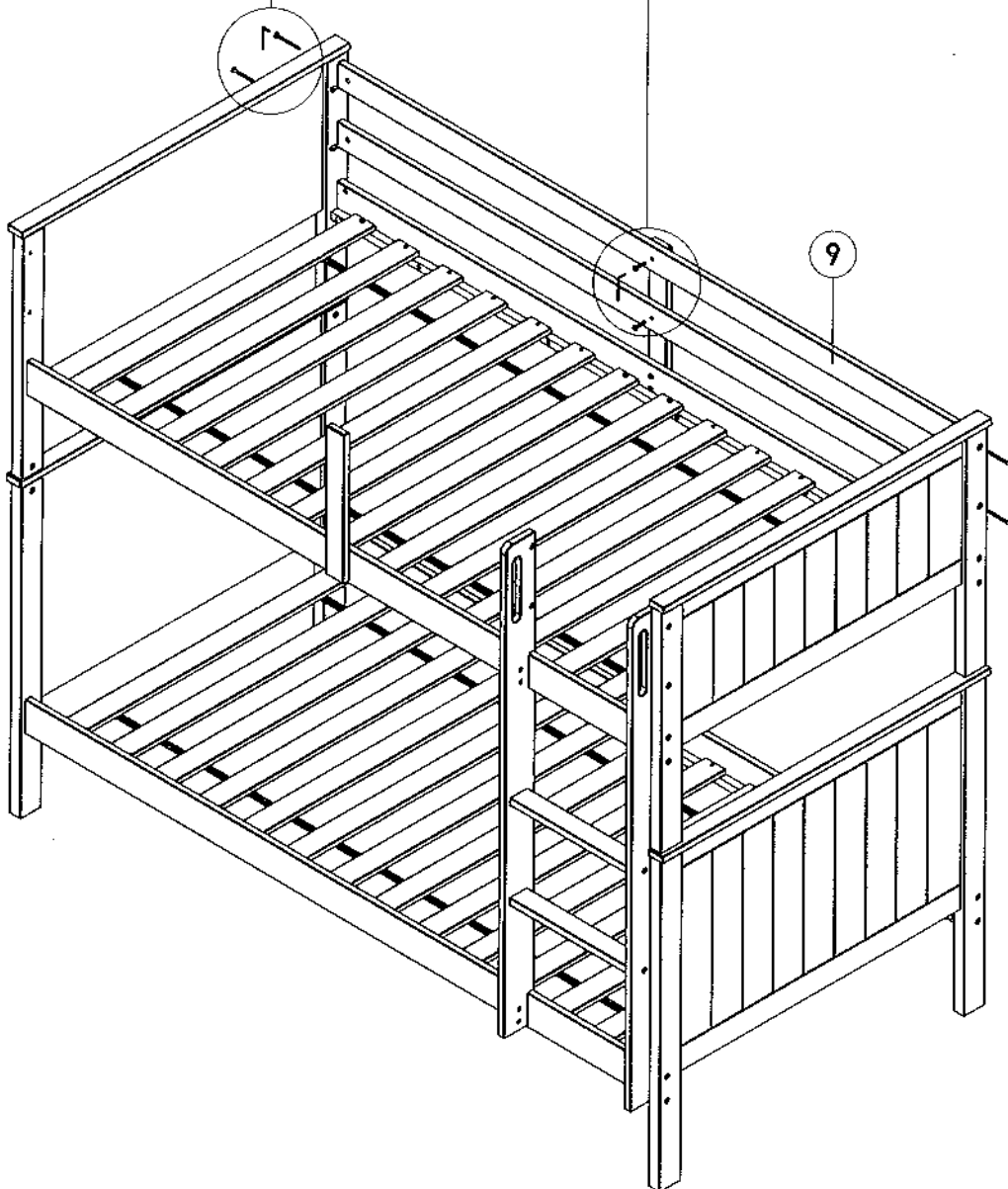
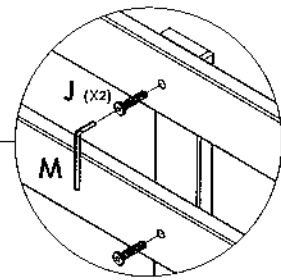
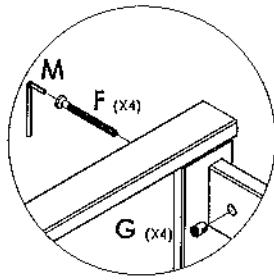

STEP 10

Attach and secure Guard Rail Support onto Full Guard Rail by using (J), tighten it up by using (M).
Attach and secure Full Guard Rail onto Top Headboard by using (F) and (G), tighten it up by using (M).

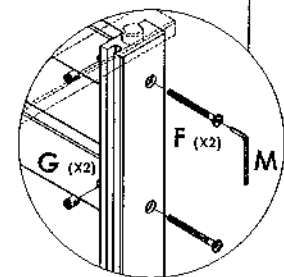
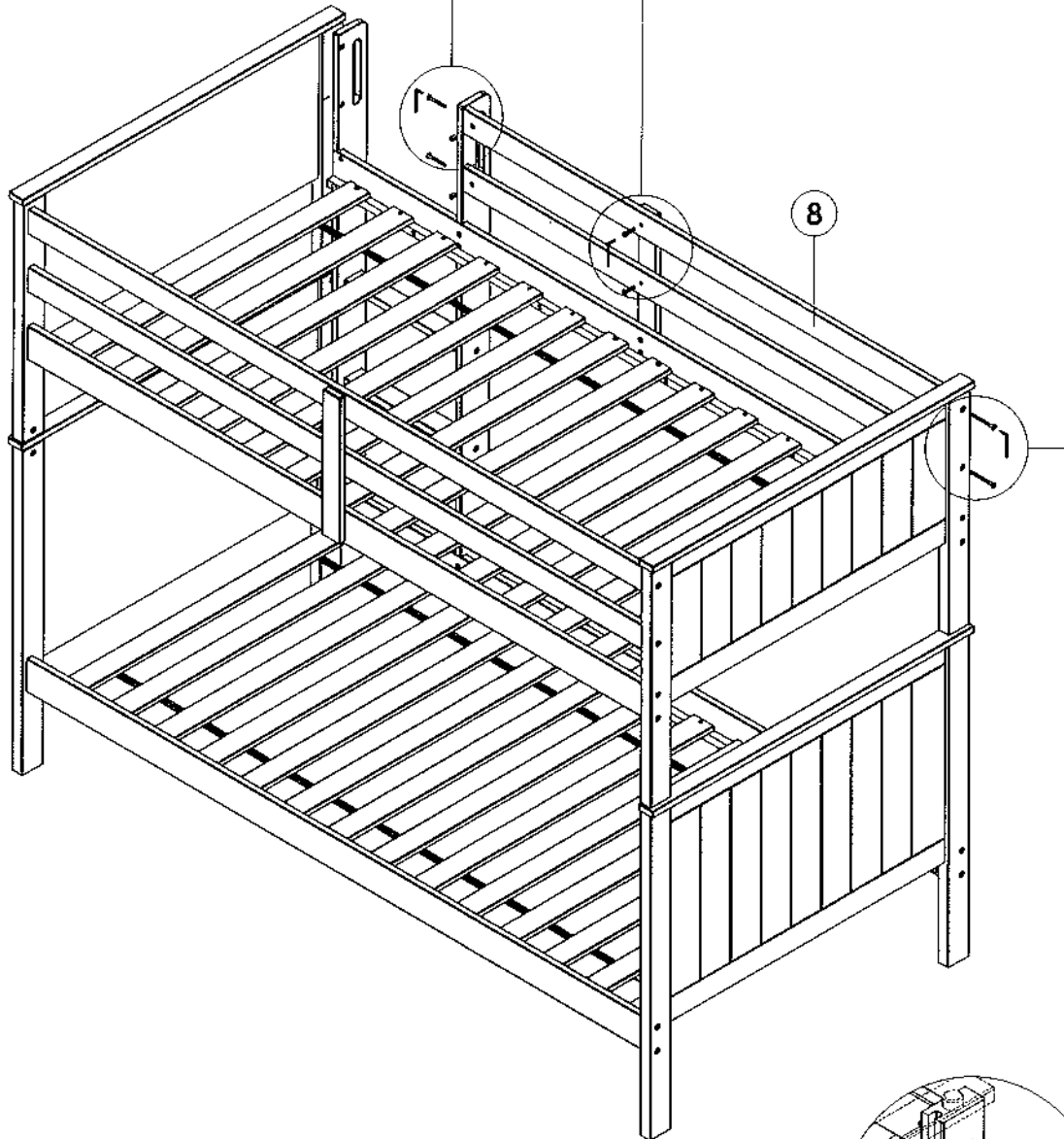
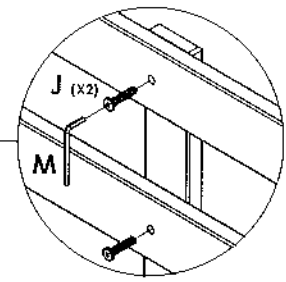
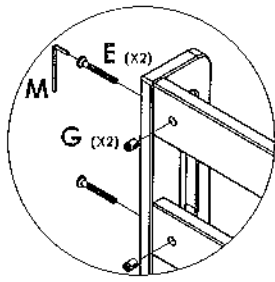

STEP 11

Attach and secure **Guard Rail Support** onto **Semi Guard Rail** by using (**J**), tighten it up by using (**M**).

Attach and secure **Semi Guard Rail** onto **Ladder** by using (**E**) and (**G**), tighten it up by using (**M**).

Attach and secure **Semi Guard Rail** onto **Top Headboard** by using (**F**) and (**G**), tighten it up by using (**M**).

Convertible Feature

This bunk bed is able to convert to 2 single beds. Follow the instructions given.

This assembly must be completed by at least 2 person.

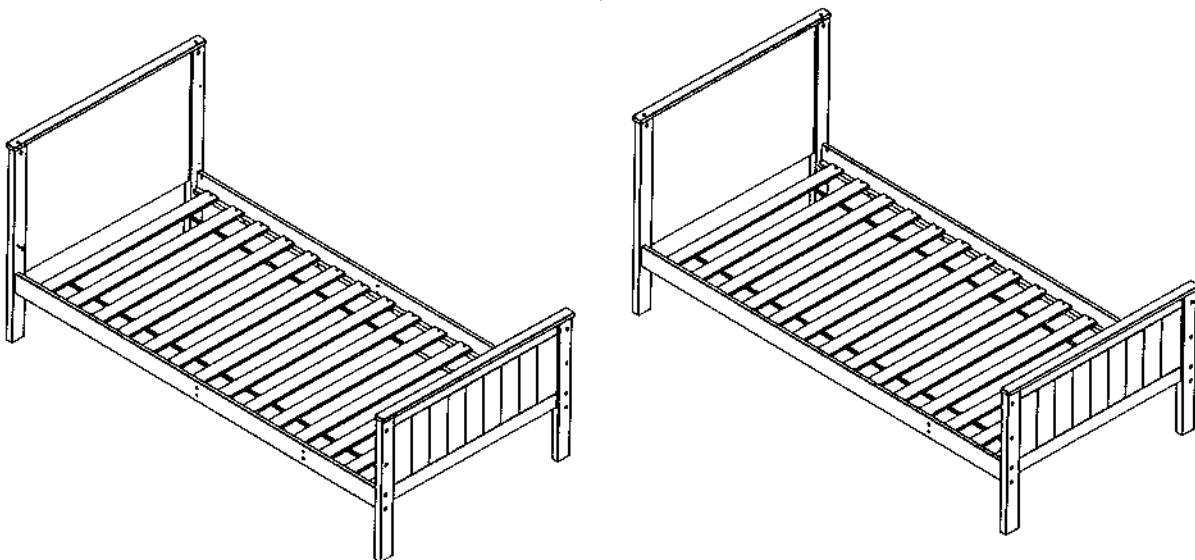
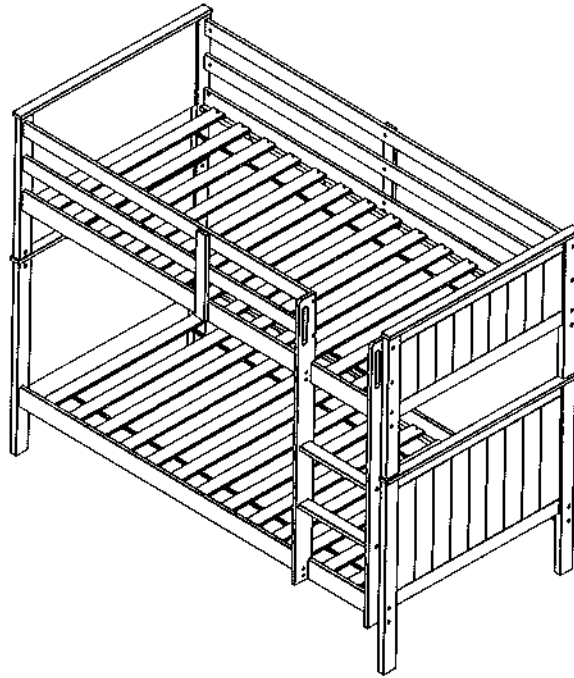

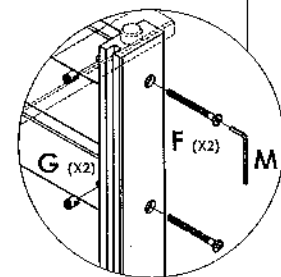
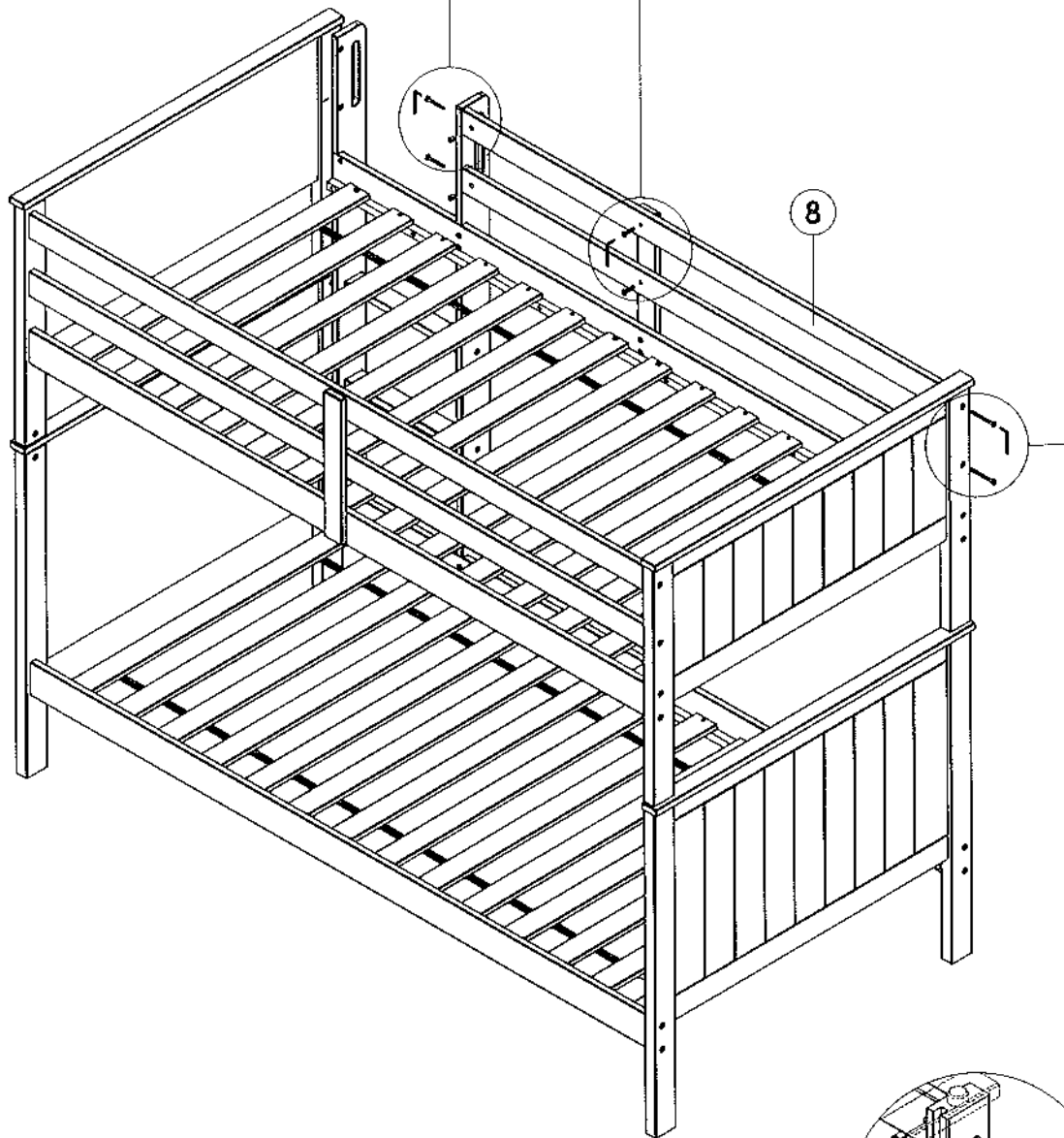
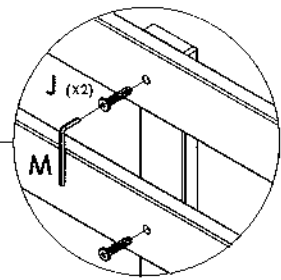
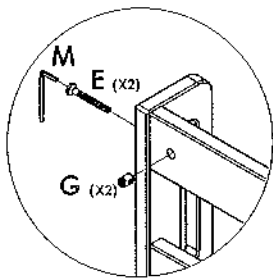

STEP 1 (Convertible)

Unscrew (J) for detach Guard Rail Support from Semi Guard Rail by using (M),

Follow that up unscrew (E) and (G) and (F) and (G) for detach Semi Guard Rail from Top Headboard and Ladder by using (M).

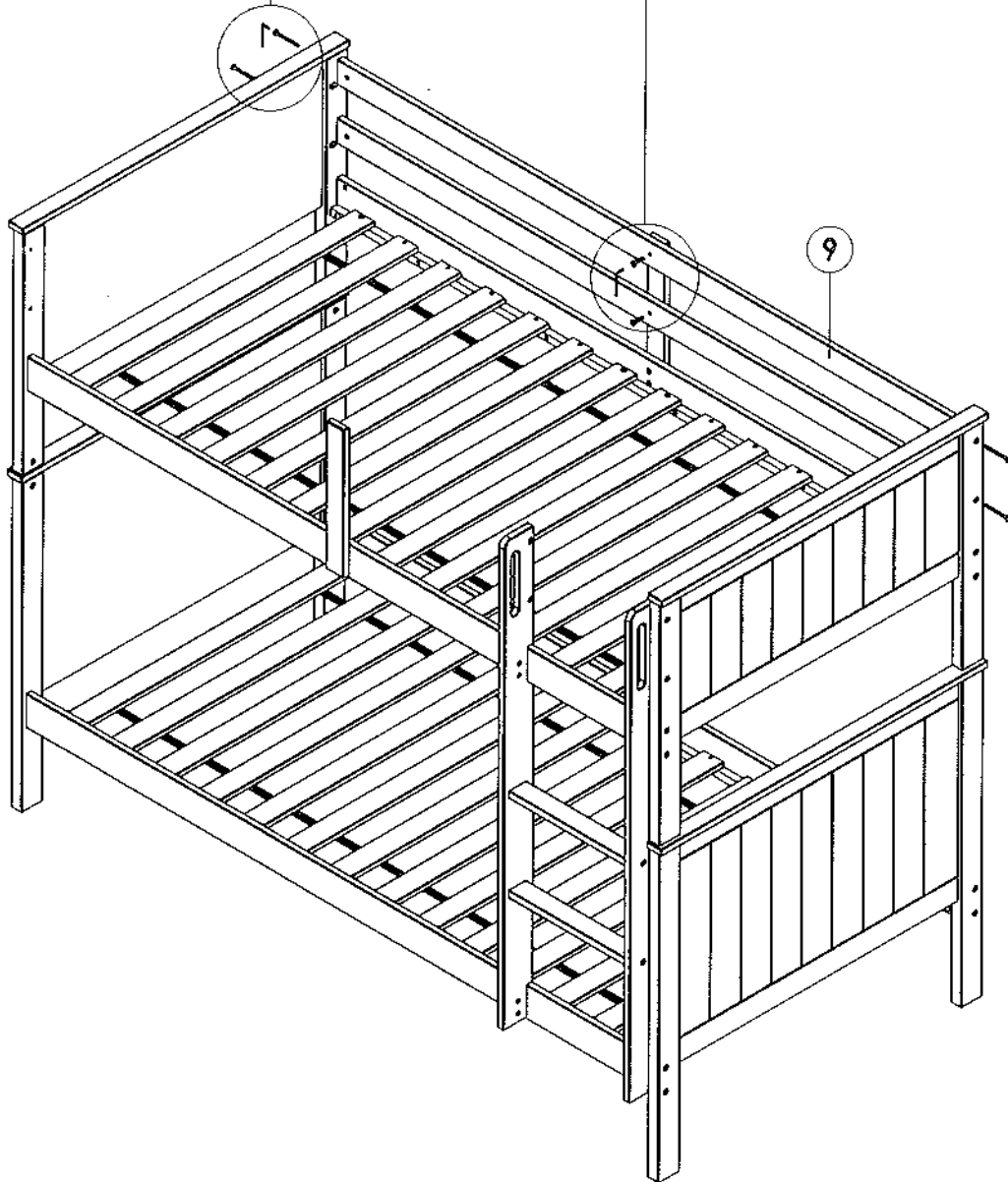
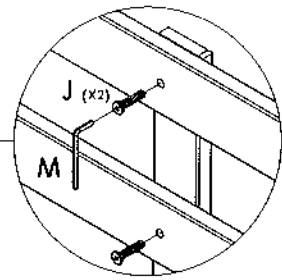
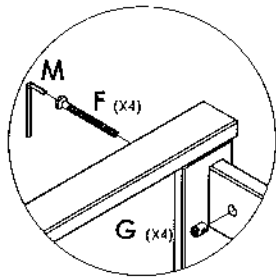

STEP 2 (Convertible)

Unscrew (J) for detach Guard Rail Support from Full Guard Rail by using (M).

Follow that up unscrew (F) and (G) for detach Full Guard Rail from Top Headboard by using (M).

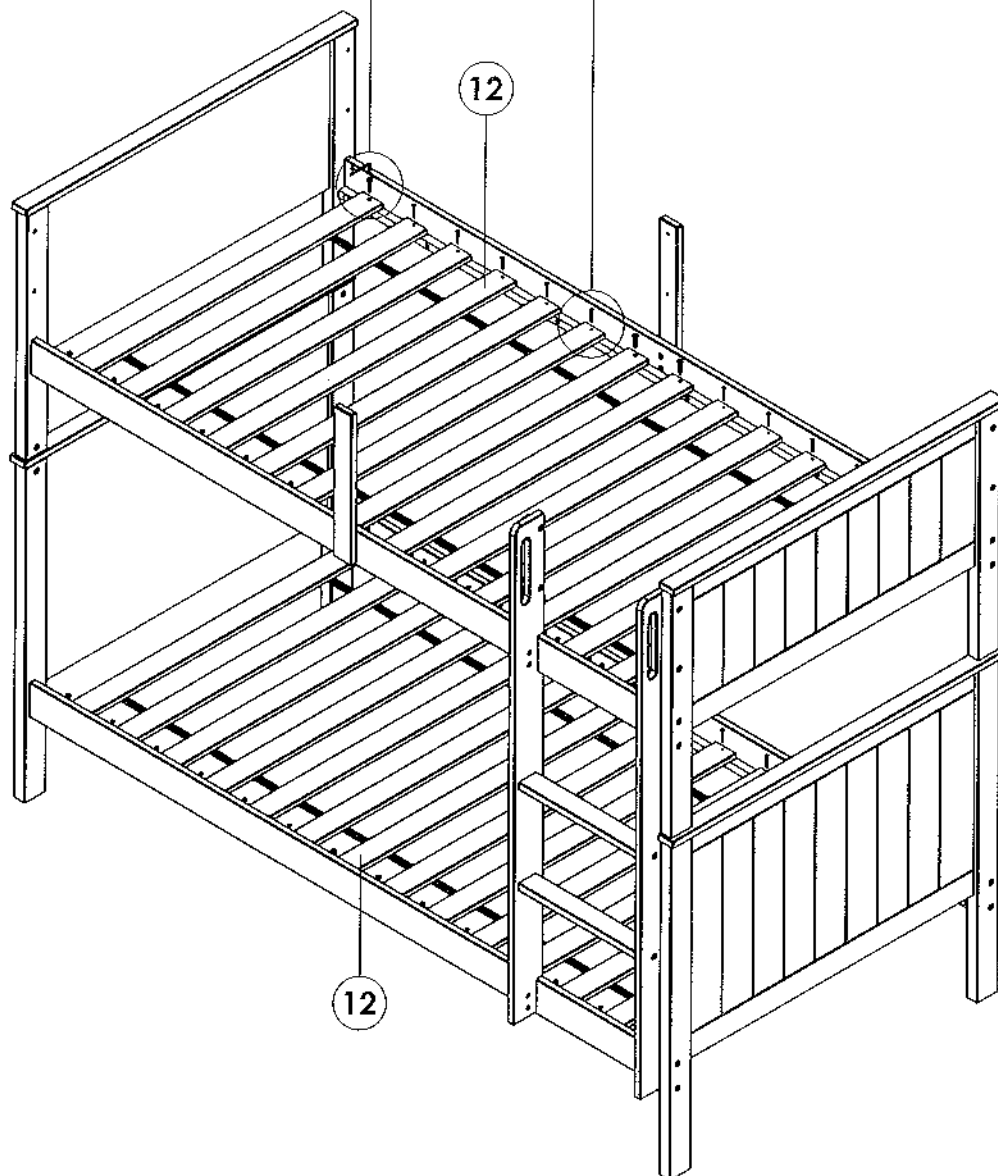
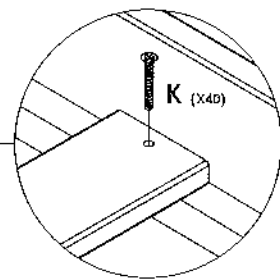
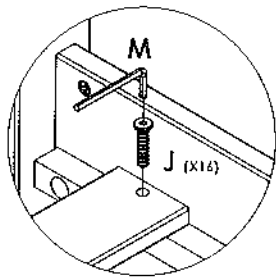

STEP 3 (Convertible)

Unscrew (J) and (K) by using (M) and a Crosshead Screw Driver and detach Wooden Slat.

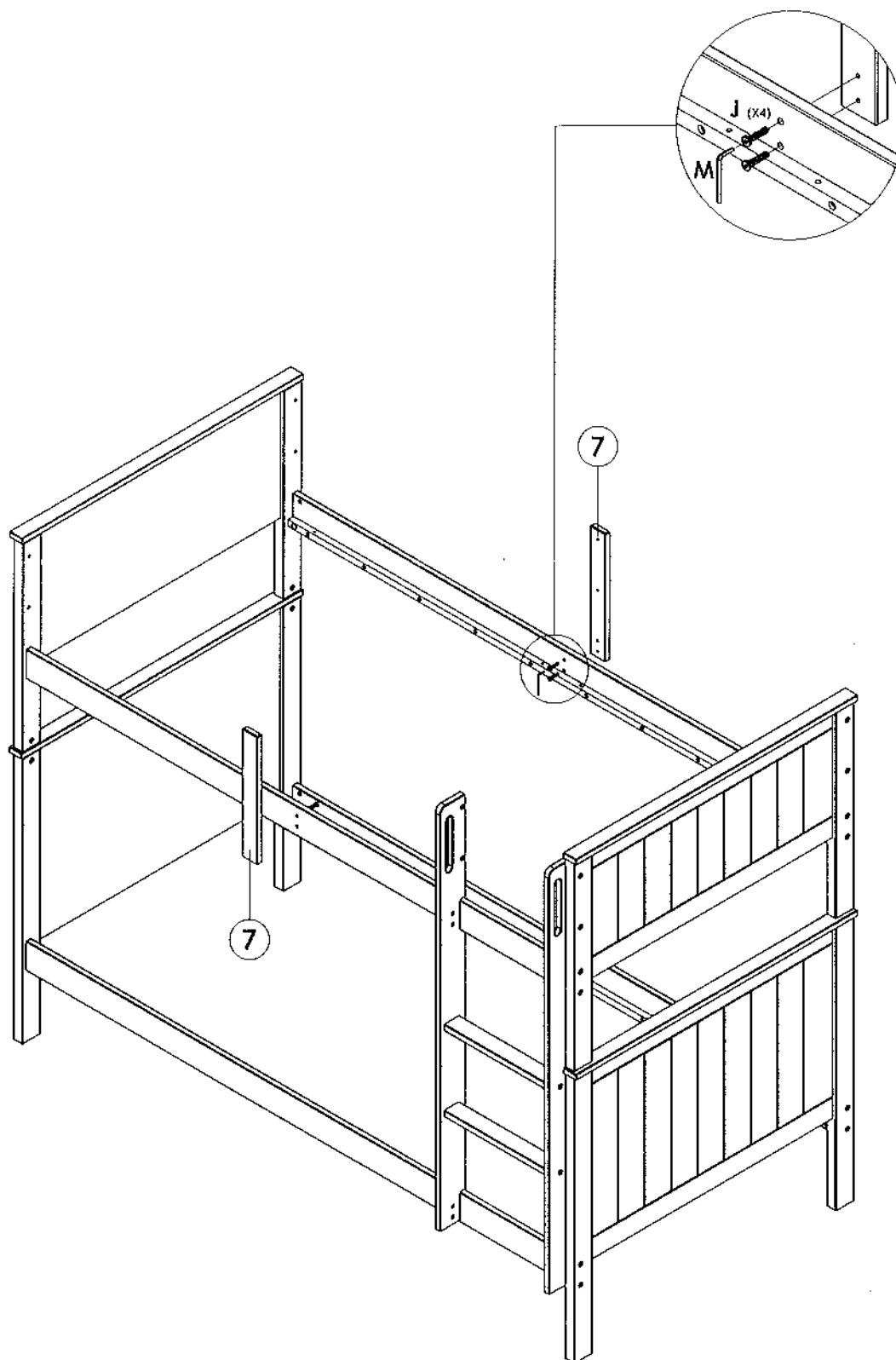

STEP 4 (Convertible)

Unscrew (J) and detach Guard Rail Support from Top Side Rail (Front) and Top Side Rail (Rear) by using (M).

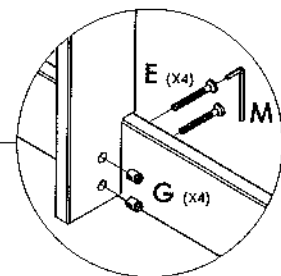
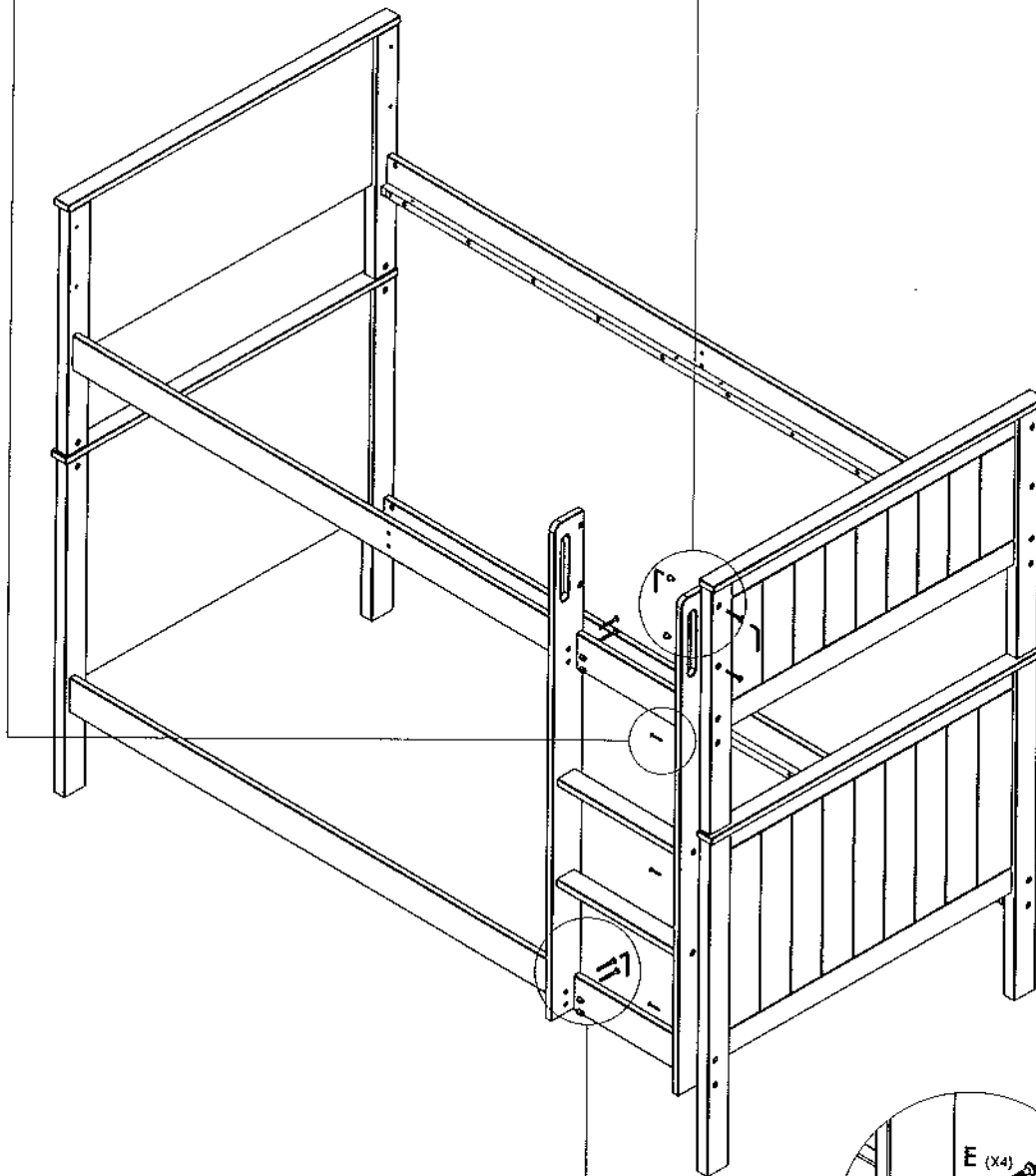
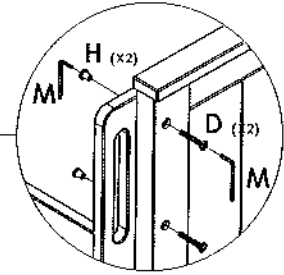
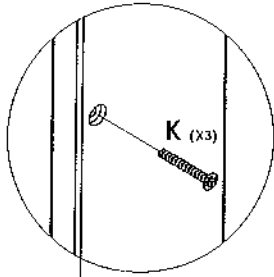

STEP 5 (Convertible)

Unscrew (K) from Ladder by using a Crosshead Screw Driver.

Follow that up unscrew (D) and (H) from Ladder and Top Headboard by using (M).

Follow that up unscrew (E) and (G) from Top Side Rail (Front) and Bottom Side Rail (Front) by using (M).

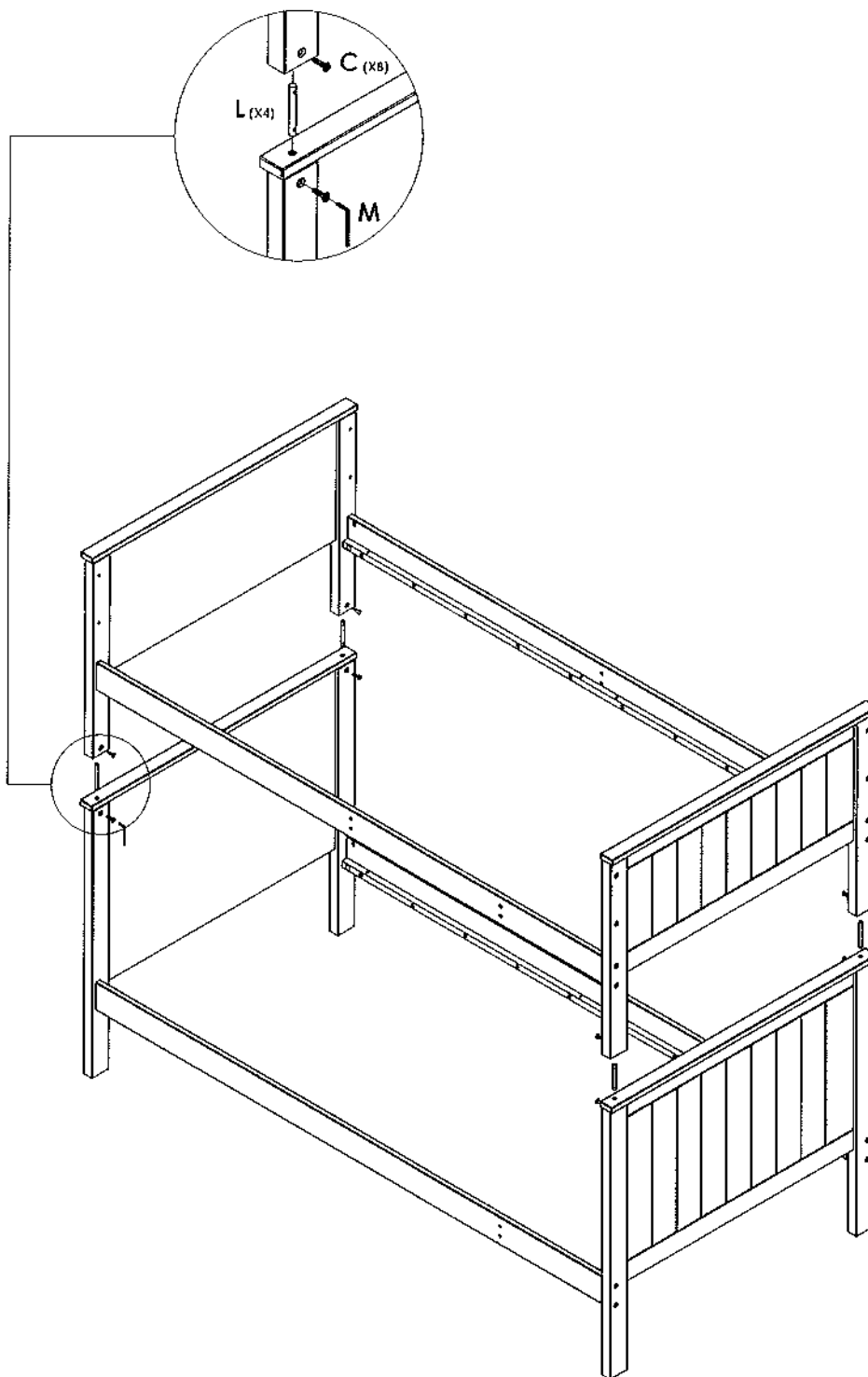

STEP 6 (Convertible)

Unscrew (C) by using (M) and unattach (L) from assembly as well.
Follow that up by separating Top Bed from Bottom Bed.

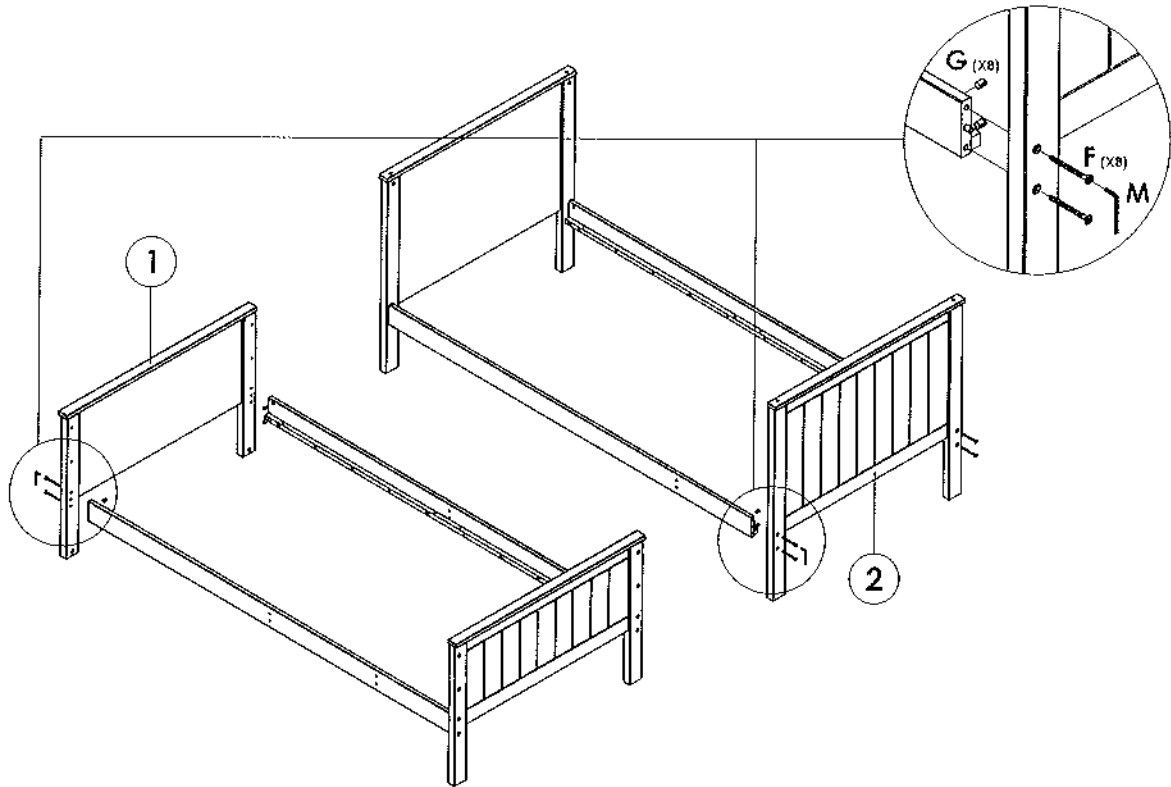

Step 7 (Convertible)

Unscrew (F) and (G) from Top Footboard & Bottom Headboard by using (M).

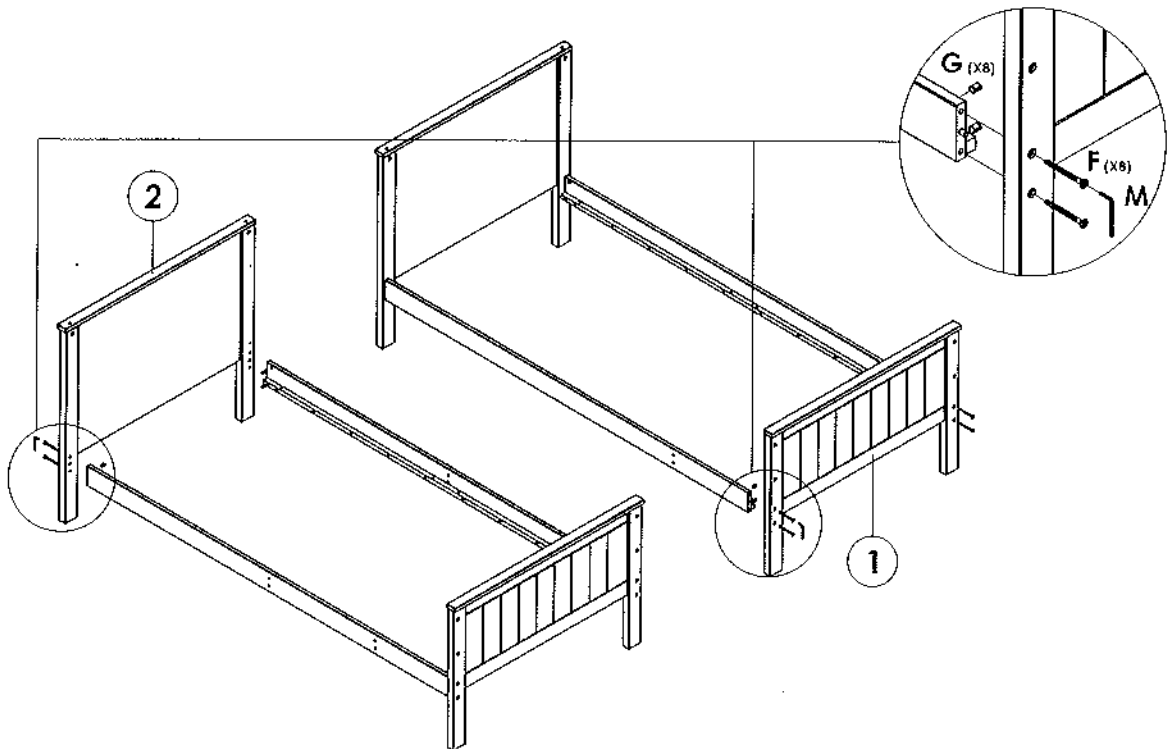

Step 8 (Convertible)

Exchange Top Footboard & Bottom Headboard, use (F) and (G) and tighten it up by (M).

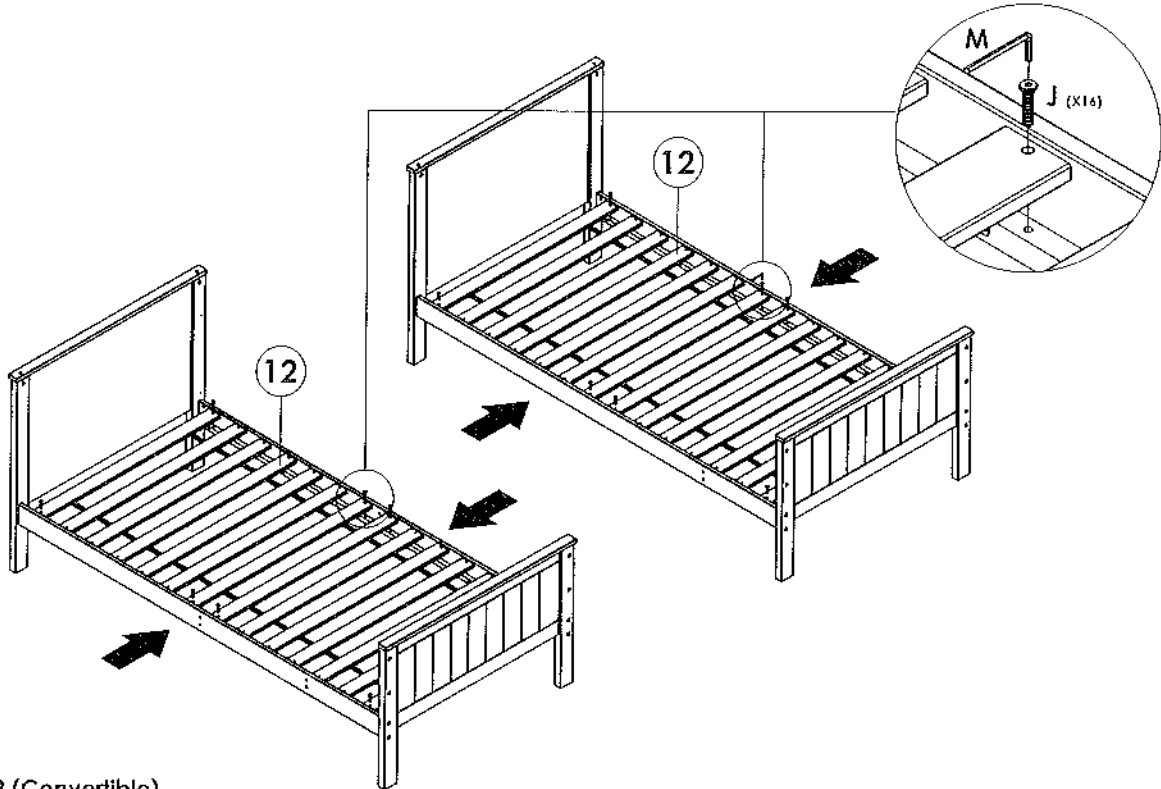

STEP 9 (Convertible)

Attach and Secure all the **Wooden Slat** onto **Side Rail** by using **(J)**, tighten it up by using **(M)**.

* Align both **Side Rail** before tightening the screws.

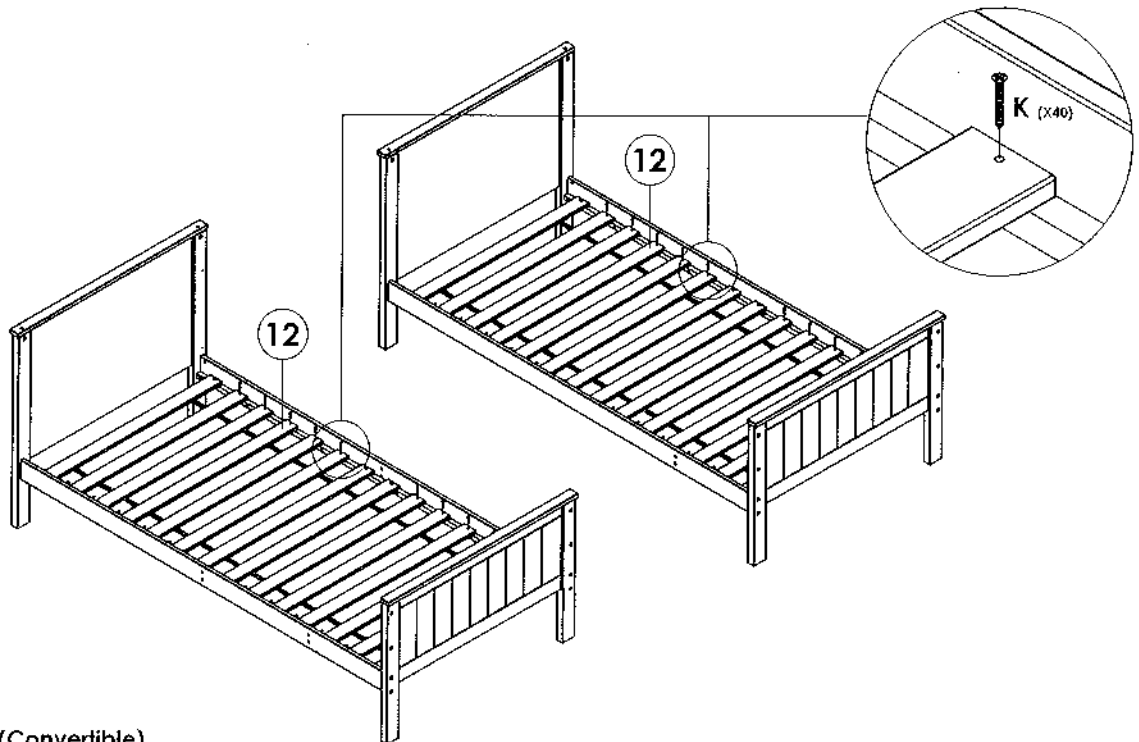

STEP 10 (Convertible)

Continue to tighten it up the next of the slat by using **(K)**, tighten it up by using a **Crosshead Screw Driver**.

* Tighten the rest of the screw.

Go on to complete the assembly of the convertible feature.