



# ***Window Air Conditioner***

## *Installation Manual*

---

GJC10BR-A6NRNJ1C (WIFI)

GJC12BR-A6NRNJ1C (WIFI)

**IMPORTANT:** Please read this manual carefully before running this unit, and save it for future reference.

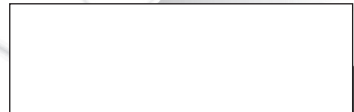



## FOREWORD

Air conditioners, heat pumps and dehumidifiers are products of high value. In order to ensure your lawful rights and interests, if you are not familiar with the installation of this type of appliance, please have a professional install the product for you. This instruction manual is the universal-purpose version for this product manufactured by Gree Canada. The appearance of the unit that you have purchased may differ from the ones seen in this manual, however it does not change the basic guidelines on how to operate this appliance.

To ensure satisfactory operation for many years to come, this manual should be read carefully before using the appliance. After reading, store in a safe place. Please refer to the manual for questions on use or in the event that any irregularities occur.

## TABLE OF CONTENT

<b>1. SAFETY PRECAUTIONS</b> .....	4
<b>2. AIR CONDITIONER OVERVIEW</b> .....	6
<b>3. AIR CONDITIONER INSTALLATION</b>	
3.1. Pre-Installation Information .....	7
3.2. Installation Instructions .....	9
<b>4. OPERATION GUIDE</b>	
4.1. Features .....	13
4.2. Control Panel Buttons and Indicators .....	14
4.3. Remote Control Button Functions .....	15
4.4. Airflow Direction Adjustment .....	16
<b>5. CARE AND MAINTENANCE</b> .....	17
<b>6. TROUBLESHOOTING</b>	
6.1. Normal Sounds .....	19
6.2. Common Issues .....	20
6.3. Malfunction Codes .....	21
<b>7. WARRANTY</b> .....	22



Electrical products should be properly disposed.  
Please recycle where facilities exist.  
Check with your local authority or retailer for recycling.

## 1. SAFETY PRECAUTIONS

The following symbols and labels are used throughout this manual to indicate immediate or potential hazards. It is the owner's responsibility to read and follow all safety information and instructions accompanying these symbols. Failure to heed safety information increases the risk of serious injury or death, property damage and/or product damage.



**DANGER**



This symbol indicates an imminently hazardous situation that, if not avoided, will cause severe personal injury, death, or substantial property damage.



**WARNING**



This symbol indicates a potentially hazardous situation that, if not avoided, can cause severe personal injury, death, or substantial property damage.



**CAUTION**



This symbol indicates a potentially hazardous situation that, if not avoided, will or can cause minor personal injury or property damage.



**WARNING**



- Use caution when unpacking and installing. The fins can be sharp and can injure you.
- Do not stop the unit by pulling the power plug. Doing so may cause electric shock or fire.
- Replace immediately any part that has become frayed or damaged. Do not use a cord that shows damage or cracks along its length or at the connector. A damaged power cord must be replaced with a new cord obtained from the manufacturer. Please contact Customer Service for replacement options.
- Do not alter the length of the power cord or share an outlet with another device. Doing so may result in electric shock or fire.
- Always use a dedicated power circuit. The voltage of the plug must match the voltage rating on the nameplate.
- The power cord is equipped with a 3-prong grounding plug that can only be used with a standard 3-prong wall outlet to minimize the risk of electric shock. If you have a 2-prong outlet, it is your responsibility to replace it with a properly grounded 3-prong wall outlet.
- Do not use an outlet if it is loose or damaged. It may cause electric shock.
- Do not open the unit during operation. Doing so may result in electric shock.
- Keep away from heaters, flammable gases, or combustibles such as gasoline, benzene, thinners, etc.
- Ventilate the room before operating the air conditioner if there is a gas leak from another appliance.
- Never use an extension cord, surge protector or power strip with this unit.
- Plug the power cord properly. Always unplug your air conditioner by pulling the power plug. Firmly grasp the plug and pull it out.
- Do not disassemble or modify the unit.
- Do not operate the unit with wet hands.
- Do not clean with water that may run inside the electrical parts of the unit. This could cause the unit to malfunction or cause an electric shock.
- Do not place objects around the air inlets or inside the air outlets.
- Turn the unit off and unplug it before cleaning.
- To prevent injury, when the air filter is to be removed, do not touch the metal parts of the unit.
- Clean only the outside of the unit, using only mild detergent.
- The filter(s) should be checked once a month, or after every 250 hours of use, to see if cleaning is necessary. Always insert the filters securely.
- Do not place heavy objects on the power cord. Make sure the power cord is not compressed.
- Turn off the main power switch when not using the unit for a long period of time.
- All air conditioners contain refrigerants which, under federal law, must be removed prior to disposal. If you are getting rid of an old product with refrigerants, check with the company handling disposal about what to do.
- These R410A air conditioning systems require contractors and technicians to use tools, equipment and safety standards approved for the use of this refrigerant.

# 1. SAFETY PRECAUTIONS

## Electrical Safety

**⚠ CAUTION:** The power cord of this air conditioner contains a current sensing device designed to reduce the risk of fire. Please refer to the *Operation of Current Device* section below for more details. If the power cord is damaged, it cannot be repaired. It must be replaced with a power cord from the product manufacturer.

- The power cord is equipped with a 3-prong grounding plug that can only be used with a standard 3-prong wall outlet to minimize the risk of electric shock. If you have a 2-prong plug, it is your responsibility to replace it with a properly grounded 3-prong wall outlet.
- Do not use a power cord that has any damage or cracks along the length or at the connector. A damaged power cord must be replaced with a new cord obtained from the manufacturer. Please contact Customer Service for replacement options.
- Do not alter the length of the power cord or share an outlet with another device. Doing so may result in electric shock or fire.
- Always use a dedicated power circuit. The voltage of the plug must match the voltage rating on the nameplate.
- Do not use an outlet if it is loose or damaged. Doing so may cause electric shock.
- Never use an extension cord, surge protector, or power strip adapter with this unit.

## Operation of Current Device

The power supply cord contains a current device that senses damage to the power cord. To test your power supply cord, do the following:

1. Plug the power supply cord.
2. The power supply cord has 2 buttons on the plug head. Press the TEST button. You should hear a clicking sound as the RESET button pops out.
3. Press the RESET button. Again, you should hear a click as the button engages.
4. The power supply cord is now supplying electricity to the unit (on some devices this is indicated by a light on the plug head).

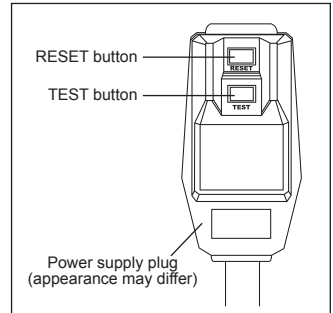

FIGURE 1

## Notes :

- Do not use the power cord to turn the unit on or off.
- Always make sure the RESET button is pressed down for proper operation.
- The power cord must be replaced if it fails to reset when the TEST button is pressed, or if it cannot be reset. Please contact Customer Service.
- If the power cord is damaged, it cannot be repaired. It **MUST** be replaced with a new power cord. Please contact customer service.

**NOTICE:** If you turn off the air conditioner, wait at least three minutes before turning it on again. This prevents the unit from blowing a fuse or tripping a circuit breaker.

## 2. AIR CONDITIONER OVERVIEW

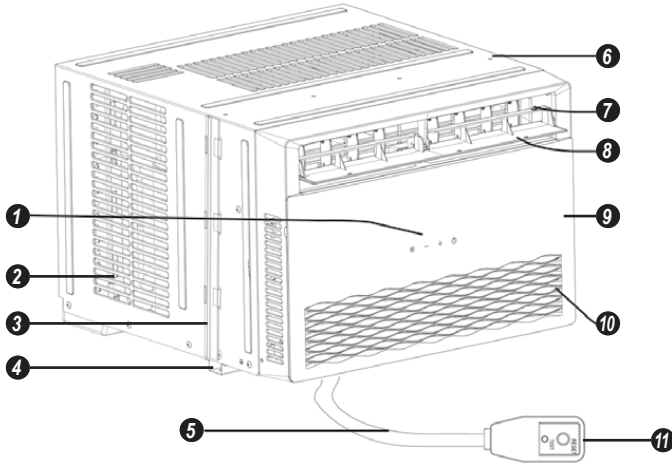

### COMPONENTS

1. Control panel	4. Bottom mounting rail	7. Air outlet	10. Air inlet
2. Exhaust air vents	5. Power cord	8. Directional flaps	11. Power plug
3. Side mounting rail	6. Top mounting rail*	9. Front panel	

\* The top mounting rail is not attached on some models.

### INCLUDED ACCESSORIES

Flexible screen panel (2)	Top mounting rail	Foam seal A (2) (adhesive)	Foam seal B (non-adhesive)	
Foam seal C (adhesive)	Sponge strip (2)	Insulation foam board (2)	Type A screws (4)	Type B screws (6)
Locking bracket (sash)	Locking bracket (2) (screen)	Battery (2) (AAA type)	Remote control	

## 3. AIR CONDITIONER INSTALLATION

### 3.1. PRE-INSTALLATION INFORMATION

⚠ **CAUTION:** When handling the unit, take care to avoid cutting yourself on the sharp metal edges and aluminum fins of the front and rear coils.

⚠ **WARNING:**

- Observe all electrical codes and ordinances.
- Do not use damaged or non-standard power cords.
- Use caution during installation and maintenance.
- Use proper operation to avoid electric shock, accidents, and other hazards.
- Proper installation is the responsibility of the installer. Incorrect installation will void the warranty.
- All parts described must be used without any substitution.

#### **IMPORTANT**

- Keep these instructions for future reference. Product failure due to improper installation is not covered by the one-year limited warranty.
- You **MUST** use the supplied installation parts and proper installation procedures as described in this manual when installing this unit.

#### **Locations to Avoid**

Installing the unit in the following locations may be dangerous and may cause malfunctions :

- Areas with strong heat sources, vapours, flammable or explosive gases, sulphate gases or volatile objects are released into the air.
- In the vicinity of high-frequency devices such as welding machines, medical equipment, etc.

#### **Electrical Connection Requirements**

- Follow the recommendations of the *Electrical Safety* section previously seen in this manual when installing the unit.
- Use a qualified electrical circuit in accordance with local safety regulations.
- Do not plug the unit into a loose or damaged electrical outlet. Doing so may result in electric shock.
- Ensure that the power supply complies with the requirements of the air conditioner. An unstable power supply or improper wiring may result in electric shock, hazard or malfunction. The electrical requirement for this product is 115V / 60Hz.
- Do not connect the unit to the power outlet before completing the installation.
- Ensure that the outlet is effectively grounded at all times, otherwise it may cause electric shock. The grounding resistance must comply with national electrical safety regulations.

### 3. AIR CONDITIONER INSTALLATION

#### Installation Location Recommendations

- Make sure there are no objects in the vicinity of the unit that could obstruct the indoor air inlet or outlet, or the outdoor exhaust air vents.
- Choose a window where condensation water can be easily dispersed to the back of the unit and will not affect others.
- The window must be able to support the weight of the unit.
- Choose a window where the noise and exhaustion air produced by the unit will not affect others.
- Choose a window that is out of the reach of children and pets.

#### NOTICE:

- The installation description refers to a standard vertical double-hung window.
- If you have to install the air conditioner in a narrow window, you may not need to install the flexible screens. Please refer to *Figure 2* for window size requirements.
- All parts must be secured to solid wood, masonry, or metal.
- The electrical outlet must be within reach of the power cord.

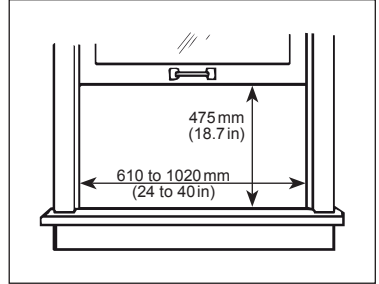

FIGURE 2

#### Adjusting to a Storm Window

A storm window frame will not allow the air conditioner to tilt toward the outside and will prevent proper draining. To adjust for this, fix a piece of wood to the window sill in order to elevate the air conditioner above the frame.

The wood piece should be 51 mm deep (2 in) and large enough to fit inside the window frame. It should be thick enough to clear the storm window frame (or vinyl frame if one is present) by 13 mm (1/2 in). Fix the wood piece securely to the sill with nails or screws (not provided).

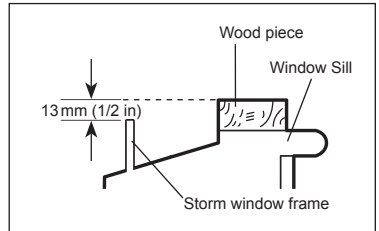

FIGURE 3

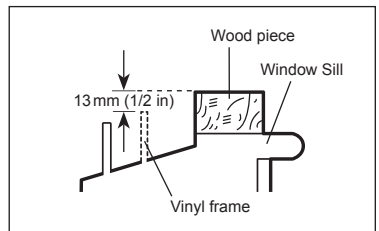





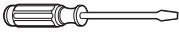
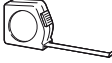

FIGURE 4



### 3. AIR CONDITIONER INSTALLATION

#### 3.2. INSTALLATION INSTRUCTIONS

##### Required Tools

 Phillips-head screwdriver	 Pencil	 Level
 Flat-head screwdriver	 Ruler or measuring tape	 Scissors or x-acto knife

- 1 Peel the film from the back of the adhesive foam seal C. Align the strip with the lower edge of the top mounting rail, then press it onto the mounting rail to seal completely.

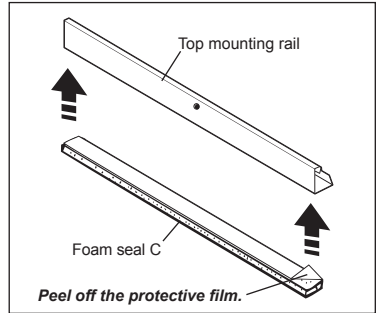

FIGURE 5

- 2 Use the type A screws provided to fix the top mounting rail to the outer case of the air conditioner (the mounting rail may be attached on some models).

**Note :** For safety reasons, all four screws must be fastened **SECURELY**.

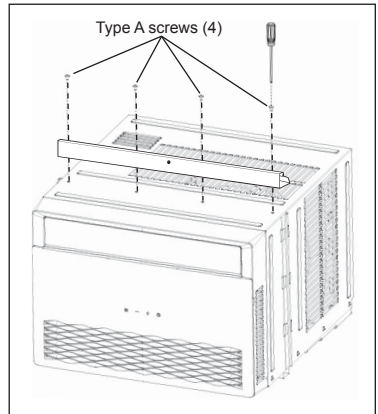

FIGURE 6

**NOTICE :** This picture is for reference only. Please refer to the actual product for the appearance.

### 3. AIR CONDITIONER INSTALLATION

- 3** Before fixing the flexible screen panels to the unit, place a piece of sponge strip along the frame on the right side of the panel marked *RIGHT*, as shown in the illustration. Repeat the same step on the left side of the panel marked *LEFT*.

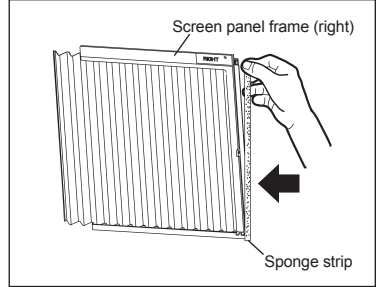

FIGURE 7

- 4** **A)** Hold the frame of the panel with one hand and pull on the screen to extend it with the other. Slide the edge of the extended screen into the rail on the side of unit all the way to the bottom.
- B)** Slide the upper and lower ends of the panel frame into the top and bottom mounting rails.

**Note:** Ensure that the screen panels marked *LEFT* and *RIGHT* are attached on their respective sides of the unit.

**NOTICE:** The top rail and side panels are each offset to provide an 8 mm (5/16 in) backward tilt angle. This is necessary for proper use and drainage of condensation water. If for some reason you do not use the side panels, this backward inclination must be maintained.

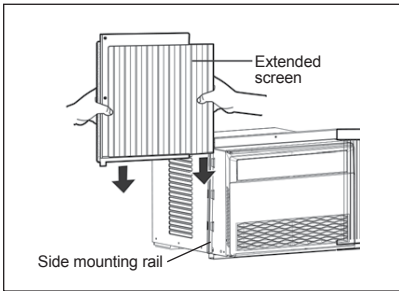

FIGURE 8

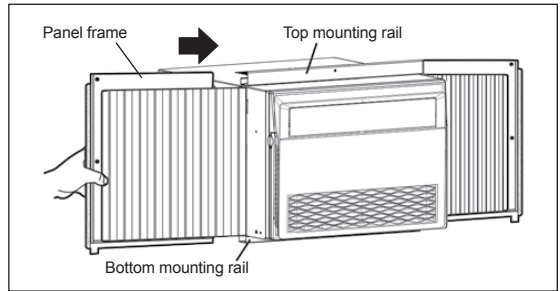

FIGURE 9

- 5** Cut a piece of adhesive foam seal A to fit the inside width of the window opening. Peel off the protective film on the back and stick the foam seal under the window sash. Stick a second piece to the bottom of the inside of the window frame at the bottom.

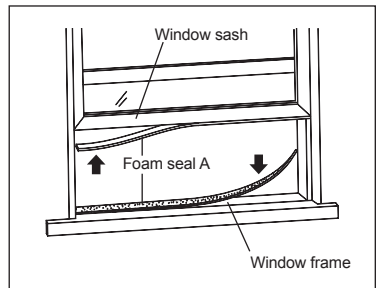

FIGURE 10

### 3. AIR CONDITIONER INSTALLATION

- 6** Place the air conditioner on the sill with the lower mounting rail against the rear edge. Center the unit and close the window securely behind the top mounting rail. The unit should be tilted slightly outwards. Use a level; one third of a bubble indicates the correct slant.

**NOTICE:** It is recommended to have a second person help lift and place the air conditioner onto the window sill.

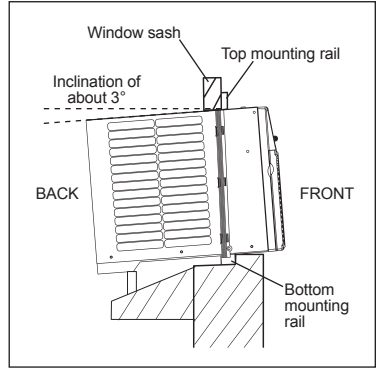

FIGURE 11

- 7** Extend the two flexible screen panels to the window frame. Using the type B screws provided, fix the side panels and top mounting rail securely to the window sash. Place the supplied locking brackets between the bottom of the screen panels and the window sill, and fasten with 2 type B screws.

**NOTICE:** To prevent the window frame from splitting, pilot holes should be made before inserting the screws.

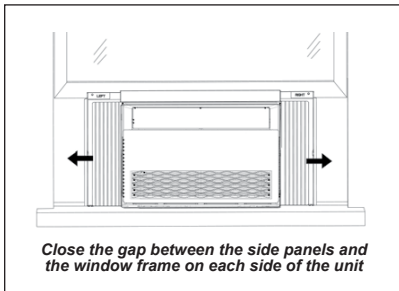

FIGURE 12

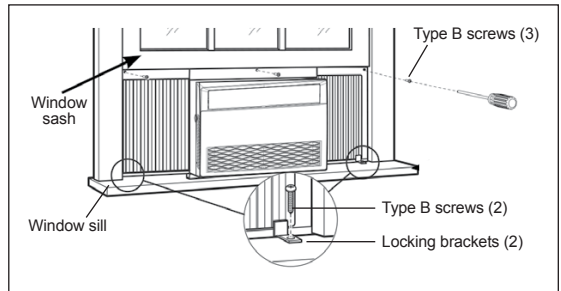

FIGURE 13

- 8** To secure to window sash, fasten the locking bracket to the window sash or frame (depending on the window type) with a type B screw. This will prevent glass breakage or damage to the windows.

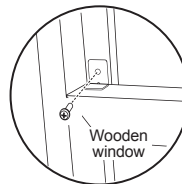

FIGURE 14

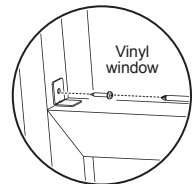

FIGURE 15

### 3. AIR CONDITIONER INSTALLATION

- 9** Insert the foam seal B between the glass and the window sash to prevent air from seeping into the room. If the strip does not fit properly to your window, acquire an appropriate material from a local store to ensure a proper seal.

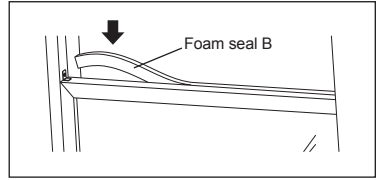

FIGURE 16

- 10** Once the installation is complete, measure the width between the air conditioner's outer casing and the window frame, as seen in *Figure 17*.

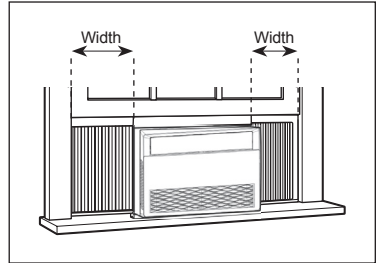

FIGURE 17

- 11** Cut the provided foam insulation board into a rectangle with a width corresponding to that measured in the previous step.

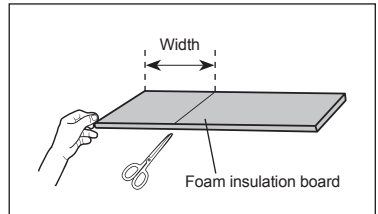

FIGURE 18

- 12** Remove the adhesive on the back of the cut piece. Stick the insulation board evenly onto the flexible screen panel. Make sure the panel is completely covered.

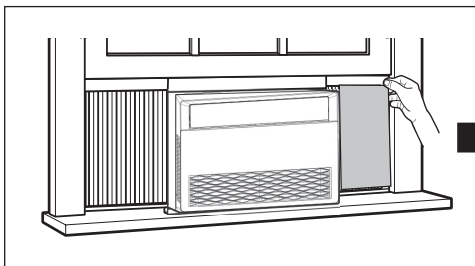

FIGURE 19

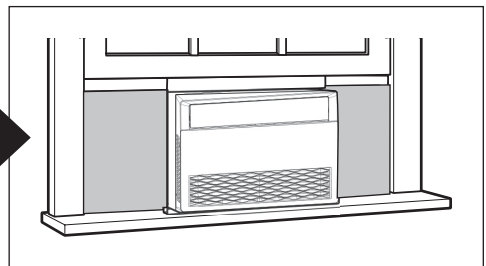

FIGURE 20

## 4. OPERATION GUIDE

### 4.1. FEATURES

#### “I Feel” LCD Remote Control

The remote control acts as a separate temperature sensor for added comfort. The mini-sensor in the remote control is able of measuring the room temperature which is then transmitted to the window unit. The unit will cool the room until the desired temperature is reached at the remote control location. The maximum transmission distance from the remote control to the unit is 8 meters (26 ft).

#### Programmable Digital Thermostat

For precise comfort control. Select the exact desired temperature for maximum comfort.

#### Programmable 24-Hour Timer

When the unit is off, allows the user to set a specific time for the unit to turn on. When the unit is on, allows the user to set a specific time for the unit to turn off.

#### 3-Speed Fan and Auto Setting

Allows more settings for maximum comfort. Auto setting automatically adjusts the fan speed according to the current room temperature and thermostat setting.

#### Evaporative Dehumidifier (Drying Mode)

Reduces and evaporates unwanted moisture without additional cooling.

#### Sleep Mode

Automatically increases the setpoint temperature by 2° after the first hour and by another 2° after the second hour. This function limits the use of the compressor and saves energy.

#### Energy Saving Mode

Automatically shuts off the compressor and fan when the desired temperature is reached to save energy.



#### Power Loss Protection with Automatic Restart

Remembers all settings when power is lost. As soon as power is restored, the air conditioner will operate in the mode, temperature and settings prior to the power outage.

#### Gold Shield

Anti-corrosion coating prevents corrosion of the condenser fins.

#### NOTICE:

- The default temperature unit on the display screen is Fahrenheit (°F). To change the display to Celsius (°C) degrees, press and hold the  and  buttons simultaneously for 3 seconds with the remote control off. Repeat the process to revert to Fahrenheit (°F).
- This cooling-only air conditioner is not designed for outdoor freezing conditions. Do not use the unit in freezing conditions.

## 4. OPERATION GUIDE

### 4.2. CONTROL PANEL BUTTONS AND INDICATORS

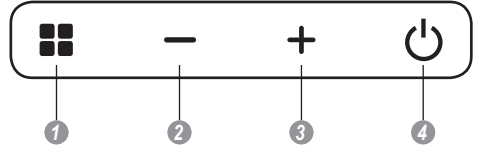
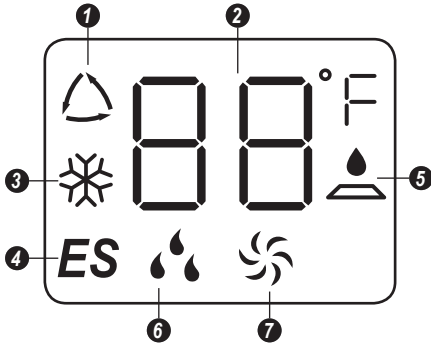

**NOTICE:** On the control panel, use the **+** and **-** keys to set the fan speed setting to *Low*, *Med* or *High*. Use the Auto pad to turn *Auto* fan speed on.

SYMBOL	INDICATOR	DESCRIPTION
1		Auto Mode Indicates that the air conditioner is operating in <i>Auto</i> mode.
2		Digital Display On normal conditions, shows the room temperature. If a timer as been set, shows the time remaining. While operating under <i>Cooling</i> , <i>Drying</i> or <i>Energy Saving</i> modes, shows the room temperature.
3		Cool Mode Indicates that the air conditioner is operating in <i>Cooling</i> mode.
4	<b>ES</b>	Energy Saver Indicates that the air conditioner is operating in <i>Energy Saving</i> mode.
5		Filter Check Indicates that the air conditioner's dust filter need cleaning.
6		Dry Mode Indicates that the air conditioner is operating in <i>Drying</i> mode.
7		Fan Mode Indicates that the air conditioner is operating in <i>Ventilation</i> mode.

SYMBOL	BUTTON	DESCRIPTION
1		Function Allows to set the air conditioner to <i>Cooling</i> or <i>Ventilation</i> mode.
2	<b>-</b>	Decrease Decreases the set temperature by 1° with each press.
3	<b>+</b>	Increase Increases the set temperature by 1° with each press.
4		Power Turns the air conditioner on or off.

## 4. OPERATION GUIDE

### 4.3. REMOTE CONTROL BUTTON FUNCTIONS

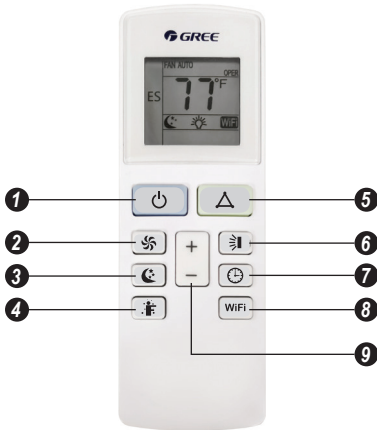

#### NOTICE :

- The distance between the remote control and the window unit must not exceed 8 meters (26ft), and there must be no obstacles in between.
- If you do not use the remote control for an extended period of time, please remove the batteries.

SYMBOL	BUTTON	DESCRIPTION
1		Power Turns the air conditioner on or off.
2		Fan Speed Selects a fan speed setting in the following order : <i>Auto, Low, Medium</i> and <i>High</i> .
3		Sleep Activates or deactivates <i>Sleep</i> mode. This function is available only in <i>Cooling, Drying</i> and <i>Energy Saving</i> mode to maintain the most comfortable temperature.
4		"I Feel" Activates or deactivates the "I Feel" function. When switched on, the remote control will serve as the ambient temperature sensor instead of the window unit in order to offer better comfort in the area of the user. If power is lost, this function will need to be reactivated.
5		Mode Selects an operation mode from the following options : <i>Auto, Cooling, Energy Saving, Drying</i> or <i>Ventilation</i> . See table below for mode description.
6		Swing Activates or deactivates the automated flap oscillation.
7		Timer Allows the setting of a switch-on or switch-off timer. Pressing this button twice will cancel any set timer.
8	WiFi	WiFi Activates or deactivates <i>WiFi</i> control.
9		Increase / Decrease While operating under <i>Cooling, Drying</i> or <i>Energy Saving</i> modes, increases or decreases the set temperature by 1° with each press. Hold the two buttons simultaneously for 2 seconds to quickly adjust the temperature on the remote control. While setting a timer, increases or decreases the time value.

SYMBOL	MODE	DESCRIPTION
1		Auto Monitors the room's ambient temperature and humidity level, and automatically adjusts to provide comfortable room temperature.
2		Cool Cools the room to the desired temperature as well as remove moisture from the air.
3		Dry Reduces humidity in the air by automatically. Fan speed cannot be adjusted in this mode.
4		Fan Operates in ventilation only.
5	ES	Energy Saver Adjusts its own operation to achieve energy-saving performance.

### 4.4. AIRFLOW DIRECTION ADJUSTMENT

#### Horizontal Airflow Adjustment

Adjust the vertical flaps to the left or right to direct the airflow according to your preference.

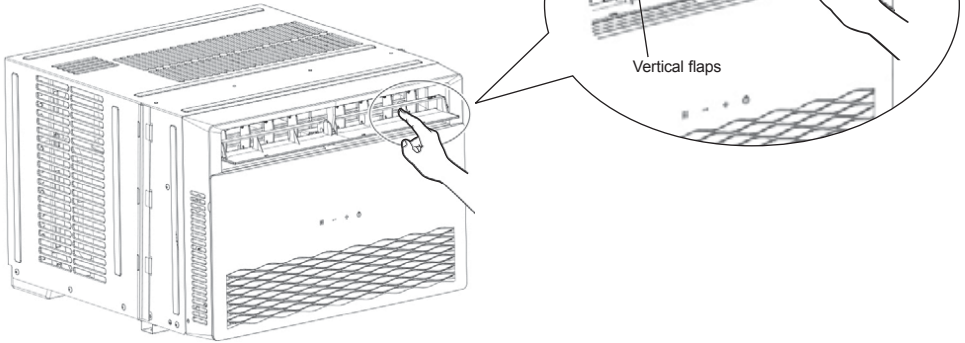

#### Vertical Airflow Adjustment

Adjust the horizontal flaps up or down to direct the airflow according to your preference.

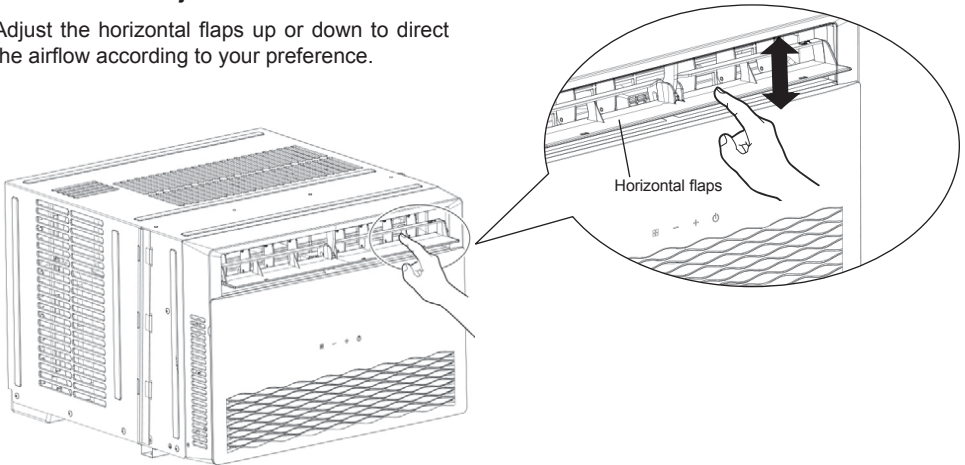

**NOTICE:** This picture is for reference only. Please refer to the actual product for the appearance.



## 5. CARE AND MAINTENANCE

### ⚠ WARNING :

- Turn off the air conditioner and unplug the power cord from the outlet before cleaning to avoid electric shock.
- Do NOT wash the air conditioner with water to avoid electric shock.
- Do NOT use harsh detergents to clean the air conditioner.
- To prevent injury, if the dust filter needs to be removed, avoid touching the metal parts of the unit.

### Cleaning the Dust Filter

1. To open the front panel, pull on the notches on both sides of the panel, as shown in *Figure 21*.
2. Remove and clean the dust filter with a clean, damp cloth or rag. If the filter is very dirty, use warm water with mild soap, then let it dry. Do not use a hair dryer or any other drying appliance.
3. Once the filter is completely dry, reinstall it inside the unit, then close the front panel securely, as shown in *Figure 22*.
4. Do not operate the air conditioner without the dust filter in place.

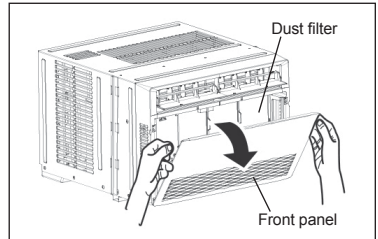

FIGURE 21

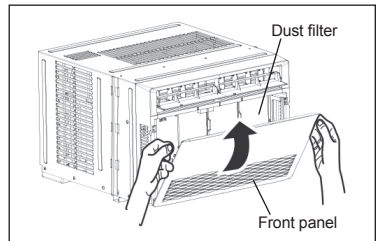

FIGURE 22

### Routine Maintenance

- Check the filter once a month or after approximately 250 hours of use to see if cleaning is needed. If the window unit is operating in a dusty environment, clean the filter more frequently.
- Avoid touching the metal fins of the air conditioner when removing the dust filter.
- To clean the surface of the unit, wipe it with a soft dry cloth.
- Periodically check the coils on the outside of the unit to ensure that they are not clogged with dirt or debris.

### NOTICE :

After 250 hours of operation, the *Filter Check* indicator will turn on.

1. Check and clean the filter.
2. Reset the *Filter Check* indicator by pressing and holding the — button for 5 seconds until a beep is heard and the indicator turns off.

## 5. CARE AND MAINTENANCE

### Post-season Storage

1. Set the temperature at 30°C (86°F) and let the unit run for half a day. This is to dry the inside of the unit.
2. Turn off the air conditioner and disconnect the power cord.
3. Clean the dust filter then put it back into the unit.
4. Clean the appliance thoroughly.
5. Take the batteries out of the remote control.
6. Cover the air conditioner and all its components with a plastic bag. Store the appliance in a cool, dry place, away from direct sunlight, extreme temperatures, and excessive dust.

### Remote Control Battery Replacement

1. Press-down the battery compartment cover on the back of the remote control, then slide it in the direction of the arrow as shown in the illustration below.
2. Replace the depleted batteries with two new 1.5V AAA batteries. Make sure the positions of the “+” and “-” polarities match the markings inside the battery compartment.
3. Replace the battery compartment cover.

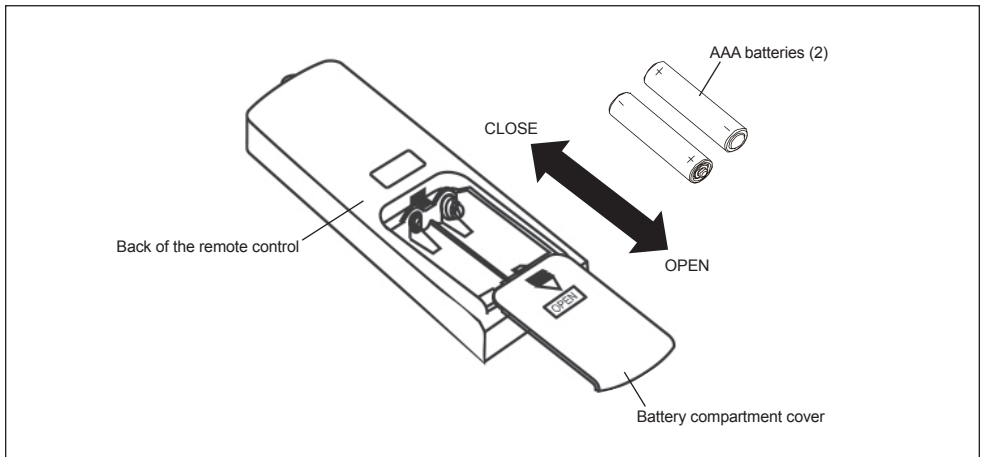

FIGURE 23

## 6. TROUBLESHOOTING

### **⚠ WARNING :**

If the situations below are observed, please turn off the air conditioner and immediately unplug the power cord from the outlet and contact Customer Service :

- Overheating or damaged power cord.
- Abnormal sounds during operation.
- Burning smell.
- Frequent automatic bouncing of the power plug *TEST* or *RESET* buttons.
- Water leakage from the front of the unit.

Do NOT attempt to repair or refit the air conditioner.

Operation of the air conditioner under these conditions may cause further malfunction, electric shock or fire hazard.

### **6.1. NORMAL SOUNDS**

Below is a description of the normal sounds you may hear when using your air conditioner. These are not malfunctions of the unit.

#### **High-pitched Sounds**

The high-efficiency compressor can make a high-pitched noise while operating in *Cooling* mode.

#### **Vibration Sounds**

If the unit is not installed correctly or if the construction of the walls or windows is poor, the unit may vibrate and make noise.

#### **Gurgling or Hissing Sounds**

You can hear these sounds as the refrigerant passes through the evaporator.

#### **Droplet Sounds**

When water hit the condenser during normal operation, they can cause droplet noise.

## 6. TROUBLESHOOTING

### 6.3. COMMON ISSUES

If your appliance appears defective, please check the possible explanations for your situation in the table below, it may be that a simple solution can help solve the problem. If the problem persists, please call **1 800 686-2175** for assistance.

SITUATION	POSSIBLE CAUSES	SOLUTIONS
The air conditioner does not work.	There is no electricity.	Connect the unit to a socket with power, or if there is a power outage, wait for electricity to be restored.
	The power plug has loosen from the outlet.	Firmly push the plug into the power outlet.
	The circuit breaker is tripped or the fuse is blown.	Replace the fuse or reset the circuit breaker. Make sure that there are no other appliances on the same circuit.
	The unit is immediately restarted after having being shut off or the operation mode has been changed.	The compressor shuts off due to changing modes. Wait 5 minutes.
	The current device of the power cord's plug is tripped.	Press the RESET button located on the power plug. If the power trips again, there is a possible malfunction with power cord or the unit. Contact Customer Service for assistance.
The efficiency of the cooling is very poor.	The set temperature is too high.	Adjust the set temperature so that it is below the ambient temperature.
	The room temperature is below 16°C (60°F).	Cooling may not occur if the room temperature is below 16°C (60°F).
	The louvers are not adjusted properly.	Check and adjust the louvers to direct the airflow.
	There is direct sunlight in the room.	Pull the curtain or close the blinds to prevent sunlight from heating the room.
	Doors or windows are opened.	Close doors and windows.
	There are a lot of people in the room.	Wait for people to leave to see if the room cools down.
	There are sources of heat present in the room.	Turn off or remove any heat sources that could be counteracting the cooling efficiency of the unit.
	The filter is dirty.	Clean or replace the air filter.
	The air vents are obstructed.	Clear objects or furniture that could be blocking the vents of the unit.
There is ice forming on back of unit.	The set temperature is too low.	Set the unit to <i>Ventilation</i> or <i>Cooling</i> mode on <i>High</i> speed and adjust the temperature higher.
The air conditioner rapidly turns on and off.	The airflow is restricted due to a dirty dust filter.	Clean or replace the air filter.
There is water dripping inside when the unit is cooling.	The air conditioner is not properly slanted backwards due to inadequate installation.	Refer to the installation instructions of this manual.
There is water dripping outside when the unit is cooling.	The ambient air is especially humid and hot.	This occurrence is normal. The unit is removing a large quantity of moisture from the room and draining it outside.
The <i>Filter Check</i> indicator will not turn off.	The unit has been operating for approximately 250 hours.	After 250 hours of operation, the <i>Filter Check</i> indicator turns on automatically. Check and clean the filter.

## 6. TROUBLESHOOTING

The remote control does not work.	The distance between the appliance and the remote control is too great.	Get closer to the unit so the remote control signal can reach the main unit's receiver.
	The remote control is not properly aligned with the main unit's signal receiver.	Make sure to be facing the unit when pressing keys on the remote control.
	There is a fluorescent lamp in the room.	Turn off the fluorescent lamp and try again, or move closer to the main unit.
	There are objects between the remote control and the main unit.	Remove any obstacles that could be blocking the signal.
	The main unit is significantly interfered with due to static pressure, unstable voltage, etc.	Unplug the power cord, wait for about 3 minutes, re-connect the plug, then turn on the unit.
	The batteries are dead.	Replace with new batteries.
The remote control "I Feel" sensing function deactivates on its own.	There was a recent power outage.	The "I Feel" function needs to be reactivated manually after a power loss.
	The remote control is outside of range of the window unit.	The remote control must be kept within 8 meters (26 ft) for the transmission signal to reach the unit.
The set temperature cannot be adjusted.	The unit is operating in <i>Auto</i> mode.	The temperature cannot be adjusted in <i>Auto</i> mode. Select a different operation mode.
	The desired temperature exceeds the temperature range.	The temperature range is 16 – 30 °C (61 – 86 °F).
There is an odd smell emanating from the appliance.	There is a person smoking a cigarette close by, or a garbage bin has been left opened in proximity to the appliance, etc., indoor or outdoor.	Odours can be caught by the appliance and spread with the airflow. Eliminate the source of the odour.

### 6.3. MALFUNCTION CODES

If any of the following malfunction codes appear on the display scree of the window unit, please call Customer Service at **1 800 686-2175** for assistance.

CODE	DESCRIPTION
F1	Malfunction of the indoor ambient temperature sensor.
F2	Malfunction of the indoor tube temperature sensor.
F4	Malfunction of the outdoor tube temperature sensor.
FJ	Malfunction of the temperature sensor at the air outlet.
EP	Malfunction of the indoor ambient temperature sensor or the indoor tube temperature sensor.
F0	Refrigerant leaking protection of the system.
H3	System overload protection.
E2	Indoor anti-freeze protection
E8	Malfunction of the indoor fan motor.

## 7. WARRANTY

### LIMITED WARRANTY

This product is covered by a warranty against defects in materials and workmanship, if used for the applications specified in this manual, for a period of **ONE (1) year** from the date of original purchase in Canada.

**Note: The compressor is covered by a 5-year limited warranty.**

During the warranty period, if the product fails under normal use, Gree Canada will, at its option, either repair the unit or replace it, free of charge, within a reasonable period of time after the product is returned. As a condition to any warranty service obligation, the customer must present this warranty certificate along with the proof of purchase.

### **THIS WARRANTY DOES NOT COVER...**

- Damage, accidental or otherwise, to the appliance that is not caused by materials or workmanship defect.
- Damage caused by misuse, tampering or failure to follow the operating and maintenance instructions provided in this manual.
- Damage to the finish of the unit enclosure or to other outer features caused by wear.
- The filters.
- Damage caused by repairs or modifications to the appliance made by any person not duly authorized by Gree Canada.
- Insurance and freight costs for the warranty service.

ALL IMPLIED WARRANTIES, INCLUDING ANY IMPLIED WARRANTY OF MERCHANTABILITY, ARE LIMITED TO A **ONE (1) YEAR** PERIOD COVERED BY THIS EXPRESS LIMITED WARRANTY. GREE CANADA DISCLAIMS ANY LIABILITY FOR CONSEQUENTIAL OR INCIDENTAL DAMAGES AND, IN NO EVENT SHALL GREE CANADA LIABILITY EXCEED THE RETAIL VALUE OF THE APPLIANCE FOR BREACH OF ANY WRITTEN OR IMPLIED WARRANTY WITH RESPECT TO THIS PRODUCT.

**Keep this manual along with your proof of purchase in a safe place for future reference. You must provide proof of purchase for warranty service.**

Enter the following information about your product; it will help you upon getting assistance or service, if you ever need it. You will have to provide the model and serial numbers of the appliance. These informations are detailed on the rating plate of the unit.

Dealer name : \_\_\_\_\_

Address : \_\_\_\_\_

Model number : \_\_\_\_\_

Serial number : \_\_\_\_\_

Date of purchase : \_\_\_\_\_