



Portable Air Conditioner

Owner's Manual

GPC06AP-A6NNA1A

IMPORTANT : Please read this manual carefully before running this unit, and save it for future reference.

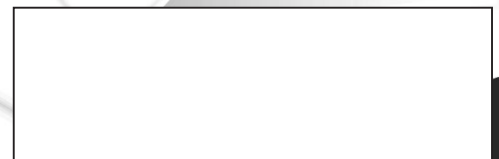

FOREWORD

Thank you for your purchase! This manual is the universal version for this product manufactured by GREE Canada. The appearance of the unit that you have purchased may differ from the one shown in this manual, however it does not change the basic guidelines on how to properly operate this appliance.

To ensure satisfactory operation for many years, this manual should be read carefully before using the appliance.

After reading, keep it in a safe place. Please refer to the manual if you have any questions about operation or if you encounter any irregularities that need to be corrected.

TABLE OF CONTENTS

1. SAFETY GUIDELINES

Safety Symbols Description	4
Exception Clauses	4
Refrigerant Specifications	5
Operation and Maintenance Safety Instructions	6

2. COMPONENT SUMMARY

Unit Components	7
Included Accessories	7

3. INSTALLATION GUIDE

Pre-Installation Information	8
Installation Instructions.....	9

4. OPERATION GUIDE

Control Panel Overview	14
Remote Controller Overview	15
Basic Operating Instructions	16
Function Descriptions and Setting	17

5. MAINTENANCE.....

19

6. TROUBLESHOOTING

Common Issues	22
Malfunction Codes	23

7. SERVICE GUIDE

Special Safety Precaution for Flammable Refrigerant	24
Electric Diagram.....	28

8. WARRANTY

29

SAFETY GUIDELINES

■ SAFETY SYMBOLS DESCRIPTION

The following symbols are used throughout this manual to indicate immediate or potential hazards. It is the owner's responsibility to read and follow all safety information and instructions accompanying these symbols. Failure to heed safety information increases the risk of serious injury or death, property damage and/or product damage.

DANGER

This symbol indicates an imminently hazardous situation that, if not avoided, will cause severe personal injury, death, or substantial property damage.

WARNING

This symbol indicates a potentially hazardous situation that, if not avoided, can cause severe personal injury, death, or substantial property damage.

CAUTION

This symbol indicates a potentially hazardous situation that, if not avoided, will or can cause minor personal injury or property damage.

NOTE

This symbol indicates that the items must be observed. Incorrect use may result in personal injury or property damage.

■ EXCEPTION CLAUSES

The manufacturer will not assume any liability when personal injury or property damage is caused by the following reasons:

1. Damage the product due to improper use or misuse of the product.
2. Modify, change, maintain or use the product with other equipment without complying with the manufacturer's instruction manual.
3. After verification, the product defect is directly caused by corrosive gas.
4. After verification, the defects are caused by mishandling during product transportation.
5. Operation, repair, maintenance of the unit without complying with the instruction manual or related regulations.
6. After verification, the problem or dispute is caused by the quality specifications or performance of parts and components produced by other manufacturers.
7. The damage is caused by natural disasters, bad operating environment or force majeure.

If it is necessary to install, move or service the air conditioner, please contact your dealer or local service center first. The appliance must be installed, moved or serviced by qualified technicians. Failure to do so may result in serious damage or personal injury, or even death.

When refrigerant leaks or must be discharged during installation, maintenance or disassembly, it must be handled by certified professionals or in accordance with local laws and regulations.

This appliance is not intended for use by persons (including children) with reduced physical, sensory or mental capabilities or lack of experience and knowledge, unless they are given supervision or instruction in its use by a person responsible for their safety.



Children should be supervised to ensure that they do not play with the unit.

SAFETY GUIDELINES

■ REFRIGERANT SPECIFICATIONS

A special refrigerant circulates in the system to achieve the air conditioning operation. The refrigerant used is fluoride R32, which is particularly environmentally friendly. The refrigerant is flammable and odorless. In addition, it can lead to an explosion under certain conditions, but the flammability of the refrigerant is very low. It can only be ignited by fire.

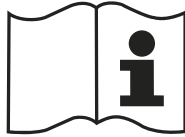
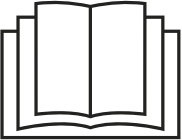
Compared to conventional refrigerants, R32 is a non-polluting refrigerant that does not harm the ozone layer. The influence on the greenhouse effect is also lower. R32 has very good thermodynamic characteristics which make it very energy efficient. The appliances therefore need less filling.

	<p>Appliance is filled with flammable R32 gas.</p>		<p>Before installing the appliance, read the Installation Guide thoroughly.</p>
	<p>Before using the appliance, read the Operation Guide thoroughly.</p>		<p>Before repairing the appliance, read the Service Guide thoroughly.</p>

⚠ WARNING:

- Please read the manual before installation, operation and maintenance.
- Do not use any means to accelerate the defrosting process, or cleaning, other than those recommended by the manufacturer.
- Do not puncture or burn the unit.
- The air conditioner must be stored in a room without continuously operating equipment (for example, an open flame, a gas ignition device in operation or an electric heater in operation).
- Please contact the nearest service center when repairs are required. When servicing the air conditioner, personnel must strictly follow the instructions provided by the manufacturer and it is forbidden for non-professionals to repair the air conditioner.
- Handling, installation, storage, maintenance and disposal must comply with the provisions of national laws and regulations, as well as national wiring regulations.
- Refrigerant must be discharged from the system when repairing or disposing of the air conditioner.
- Be aware that refrigerant can be odourless.
- The appliance must be stored in a well-ventilated area where the size of the room matches the area of the room as specified for operation.
- The appliance must be stored in such a way as to prevent mechanical damage.
- Ensure that required ventilation openings are not obstructed.

SAFETY GUIDELINES

■ OPERATION AND MAINTENANCE SAFETY INSTRUCTIONS

⚠ WARNING :

- This appliance is not intended for use by persons (including children) with reduced physical, sensory or mental capabilities or lack of experience and knowledge, unless they are given supervision or instruction in its use by a person responsible for their safety.
- Children should be supervised to ensure that they do not play with the unit.
- Cleaning and maintenance should not be performed by unsupervised children.
- Use caution when unpacking and installing. The fins can be sharp and can injure you.
- Do not stop the unit by pulling the power plug. Doing so may cause electric shock or fire.
- Replace immediately any part that has become frayed or damaged. Do not use a cord that shows damage or cracks along its length or at the connector. A damaged power cord must be replaced with a new cord obtained from the manufacturer. Please contact Customer Service for replacement options.
- Do not alter the length of the power cord or share an outlet with another device. Doing so may result in electric shock or fire.
- Always use a dedicated power circuit. The voltage of the plug must match the voltage rating on the nameplate.
- The power cord is equipped with a 3-prong grounding plug that can only be used with a standard 3-prong wall outlet to minimize the risk of electric shock. If you have a 2-prong outlet, it is your responsibility to replace it with a properly grounded 3-prong wall outlet.
- Do not use an outlet if it is loose or damaged. It may cause electric shock.
- Do not open the unit during operation. Doing so may result in electric shock.
- Keep away from heaters, flammable gases, or combustibles such as gasoline, benzene, thinners, etc.
- Ventilate the room before operating the air conditioner if there is a gas leak from another appliance.
- Never use an extension cord, surge protector or power strip with this unit.
- Plug the power cord properly. Always unplug your air conditioner by pulling the power plug. Firmly grip the plug and pull it out.
- Do not disassemble or modify the unit.
- Do not operate the unit with wet hands.
- Do not clean with water that may run inside the electrical parts of the unit. This could cause the unit to malfunction or cause electric shock.
- Do not place objects around the air inlets or inside the air outlets.
- Turn the unit off and unplug it before cleaning.
- To prevent injury, when the air filter is to be removed, do not touch the metal parts of the unit.
- Clean only the housing of the unit, using only mild detergent.
- The filter(s) should be checked once a month, or after every 250 hours of use, to see if cleaning is necessary. Always insert the filters securely.
- Do not place heavy objects on the power cord. Make sure the power cord is not compressed.
- Turn off the main power switch when not using the unit for a long period of time.
- All air conditioners contain refrigerants which, under federal law, must be removed prior to disposal. If you are getting rid of an old product with refrigerants, check with the company handling disposal about what to do.
- These R32 air conditioning systems require contractors and technicians to use tools, equipment and safety standards approved for the use of this refrigerant.





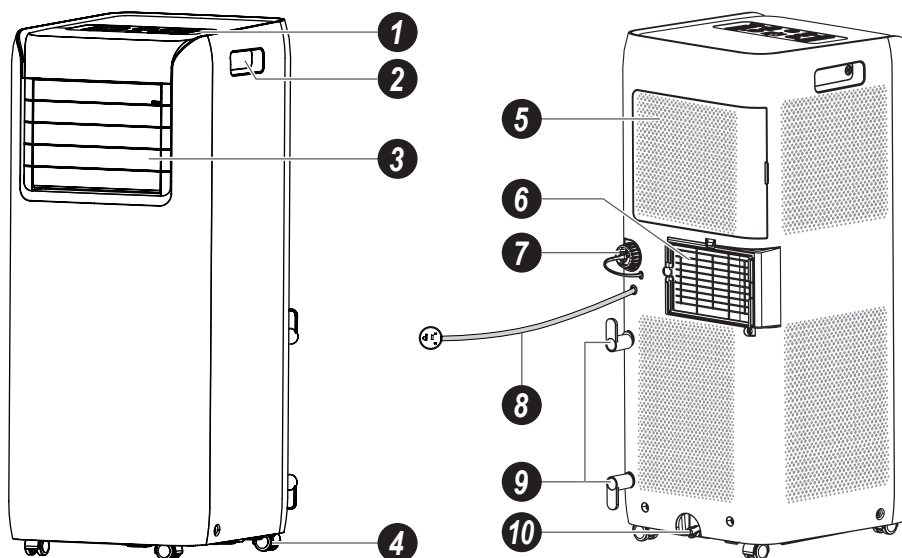

COMPONENT SUMMARY

UNIT COMPONENTS

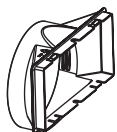
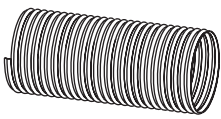
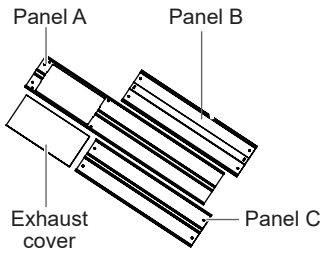
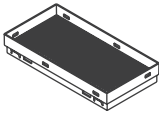
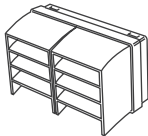
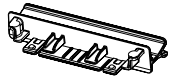
1	Control panel
2	Pocket handle
3	Airflow deflectors
4	Castors
5	Air filter access
6	Heat exhaust port
7	Continuous drain port
8	Power cord & plug
9	Cord winding hooks
10	Manual drain port

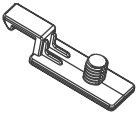
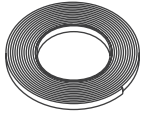

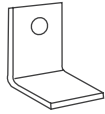
INCLUDED ACCESSORIES

				
Exhaust fitting	Window fitting	Flexible exhaust hose	Window kit	
				
Insect guard	Rain guard	Fixing base (x2)	Plastic bolt (x2)	Fixing clip (x2)
				
Foam seal A	Foam seal B	Power cord winding hook (x2)	Bracket	Screw (x4)

NOTE: The above illustrations are only intended to be simplified representations of the appliance and may not reflect the exact appearance of the product purchased.

INSTALLATION GUIDE

■ PRE-INSTALLATION INFORMATION

ELECTRICAL CONNECTION REQUIREMENTS

- Comply with electrical safety regulations when installing the appliance.
- Use an electrical circuit that complies with local safety regulations.
- If the power cord is damaged, it must be replaced by the manufacturer, its service agent, or similarly qualified persons to avoid any hazards.
- Do not plug the unit into a loose or damaged electrical outlet. Doing so may cause an electrical shock.
- Ensure that the power supply complies with the requirements of the air conditioner. An unstable power supply or improper wiring may result in electric shock, hazard or malfunction. The electrical requirement for this product is 115V / 60Hz.
- Do not plug the unit into the power outlet until installation is complete.
- The air conditioner must be properly grounded with a specialized grounding device by a professional. Please make sure that it is always grounded effectively, otherwise it may cause electric shock.
- The yellow-green wire or the green wire of the air conditioner is a grounding wire, which must not be used for any other purposes.
- The grounding resistance must comply with national electrical safety regulations.

INSTALLATION LOCATION RECOMMENDATIONS

- Choose a location where operating noise and exhaust air will not affect the neighborhood.
- The air inlet should be free of obstructions and no objects should be placed near the air outlet, otherwise it may affect the heat discharge of the exhaust hose.
- Make sure the unit has sufficient clearance from walls and furniture (as seen in Figure 1).
- Keep away from fluorescent lights.
- Prohibit installing the unit in the following

locations as it may be dangerous and may cause malfunctions :

- 1) Areas with strong heat sources, vapours, flammable or explosive gases, sulphate gases or where volatile objects are released into the air.
- 2) In proximity to high-frequency devices such as welding machines, medical equipment, etc.
- 3) Areas near the coast.
- 4) Areas with oil or fumes in the air.
- 5) Areas with sulfurous gas.
- 6) Any other area with special circumstances.
- 7) A laundry room.
- 8) An unstable or moving base structure (such as a truck) or in a corrosive environment (such as a chemical factory).

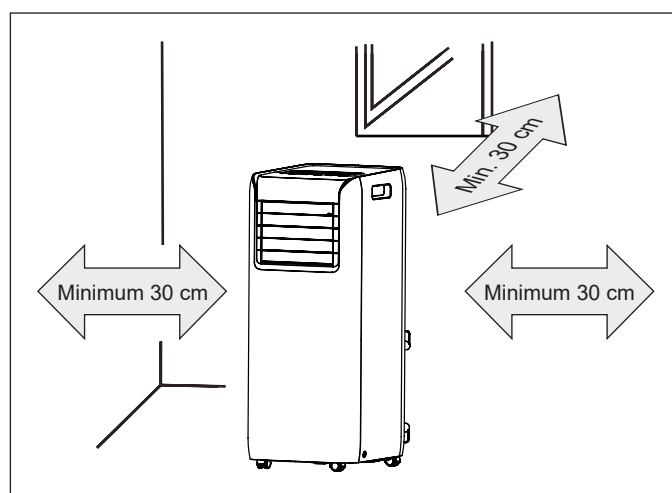

FIGURE 1

INSTALLATION GUIDE

■ INSTALLATION INSTRUCTIONS

⚠ WARNING:

- Observe all electrical codes and ordinances.
- Do not use damaged or non-standard power cords.
- Use caution during installation.
- Proper installation is the responsibility of the installer. Incorrect installation will void the warranty.
- All parts described must be used without any substitution.

REQUIRED TOOLS

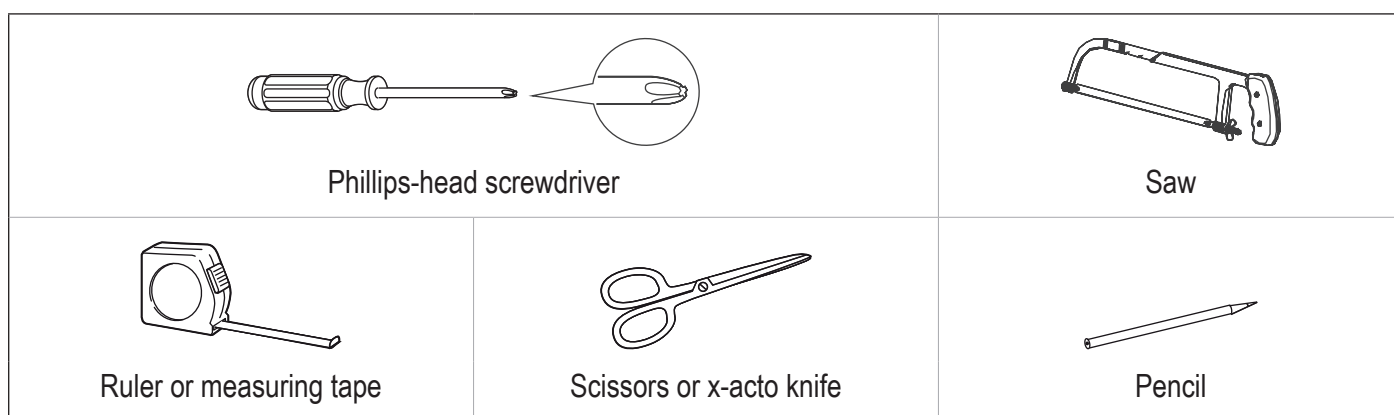

CORD WINDING HOOKS INSTALLATION

1. Fasten the power cord winding hooks to the back of the appliance with the screws provided (the direction of the hooks is shown in Figure 2).
2. Wind the power cord around the hooks.

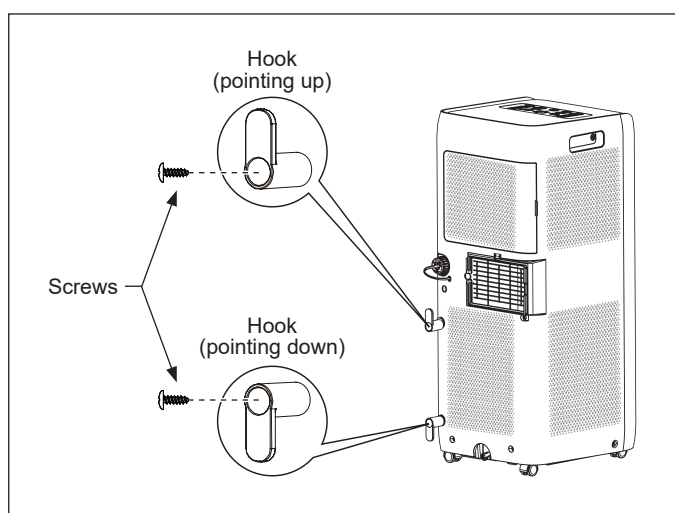

FIGURE 2

WINDOW KIT INSTALLATION

Here are the detailed instructions for installing the window kit in double-hung or sliding windows. For some windows, such as a casement window, you will have to improvise several steps of the installation, as each window is different.

1. Cut the foam seal B (adhesive type) to the required length and attach it horizontally or vertically depending on your type of window.

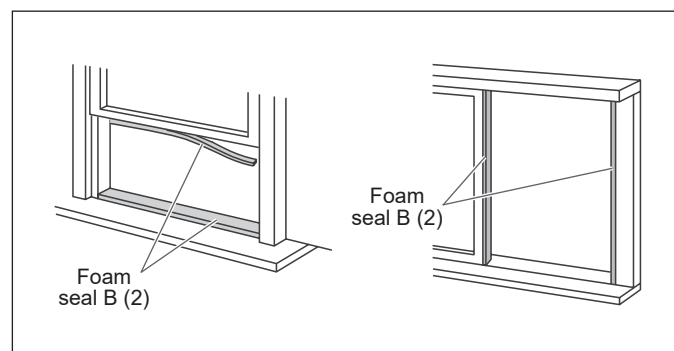

FIGURE 3

INSTALLATION GUIDE

2. Attach the insect guard to the back of the main window panel (panel A). Push it in to make sure it fits properly. If you do not want to install the rain guard, proceed to Step 4.

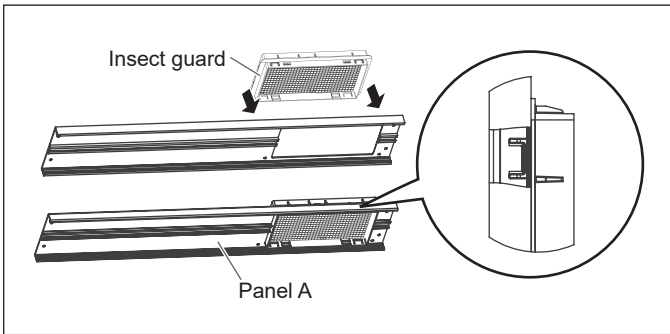

FIGURE 4

3. **Optional:** Install the rain guard on the insect guard to prevent rainwater from entering the exhaust pipe.

- a) Slide the projections of each rain guard into the notches of the insect guard. Side "A" should be on top as indicated in the illustration below.

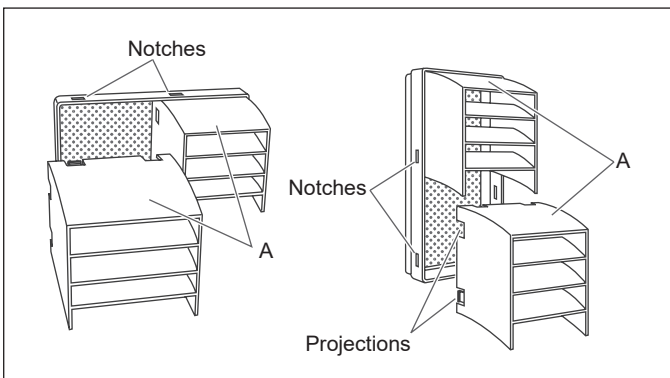

FIGURE 5

- b) Firmly insert the insect guard to ensure that the four projections fit into the notches in the main window panel (panel A). Make sure the "A" side is on top.

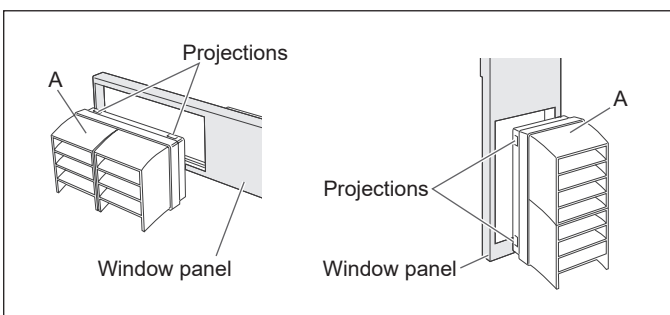

FIGURE 6

4. Slide the exhaust cover into the grooves of the main window panel (panel A).

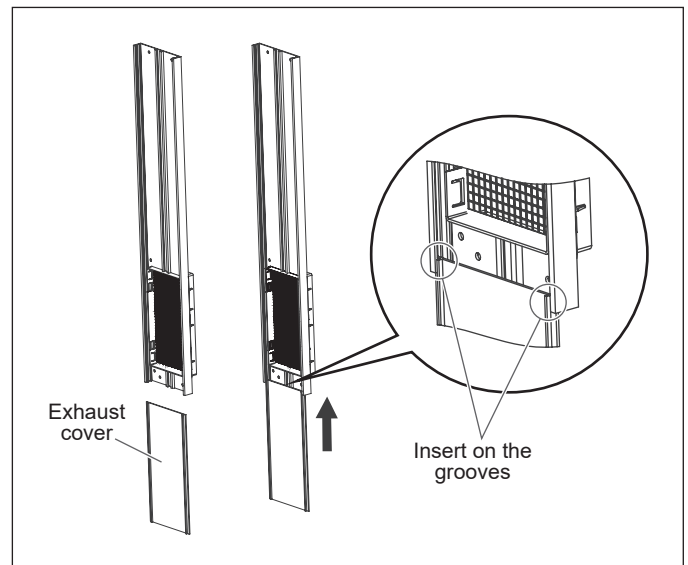

FIGURE 7

5. Installing the Window Panel(s):

This window kit consists of 3 panels that can be adjusted to the exact size of your window. You may not need to use all three panels. To get started, please refer to the guide below:

- If your window is less than 71 cm (28 inches) long you only need the window panel A. You may need to saw off part of the panel if your window is smaller than the window panel length.
- If your window is 71 to 117 cm (28 to 46 inches) long, you will need panel A and panel B. You will not need the extension panel C.
- If your window is 117 to 157 cm (46 to 62 inches) long, you will need all three panels.
- Finally, if your window is longer than 157 cm (62 inches), you will need all three panels and then have to improvise to fill the remaining space.

See next page for specific dimensions of each panel.

INSTALLATION GUIDE

PANEL A (cut if necessary)

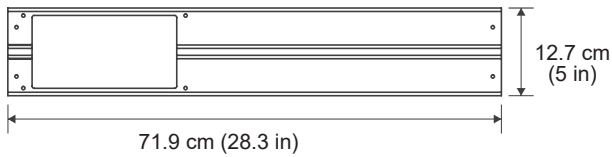

PANEL B

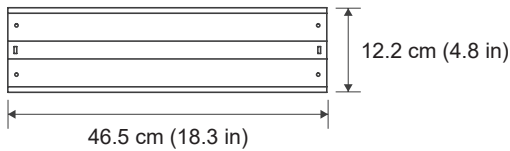

PANEL C

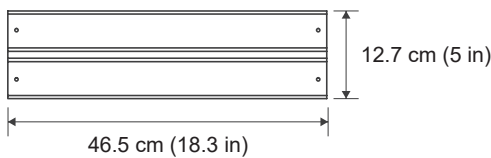

DOUBLE-HUNG SASH WINDOW

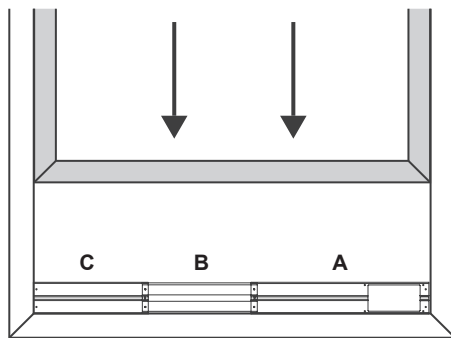

Window width:
Maximum 157 cm (62 in)
Minimum 23 cm (9.1 in)

SLIDING WINDOW

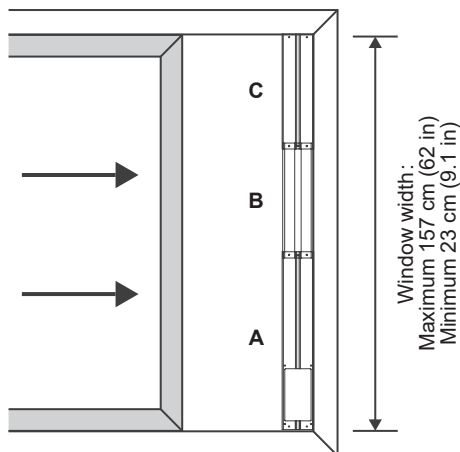

- Locate panel B (the one with grooves on each side lengthwise), a fixing clip and plastic bolt.
- Insert the fixing clip into the middle groove of panel B.

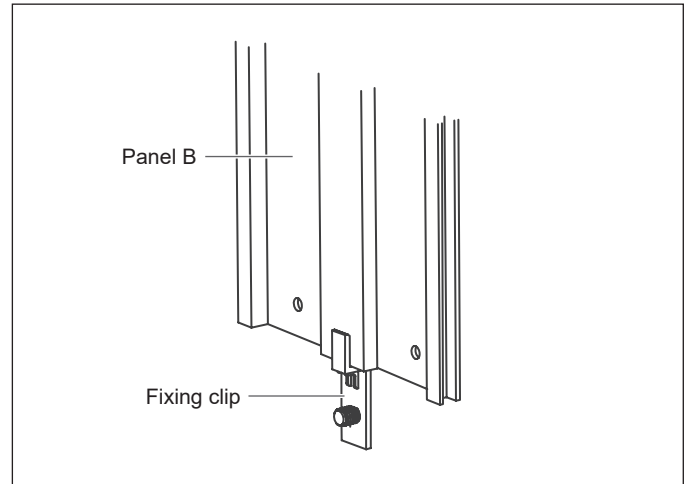

FIGURE 8

- Insert the fixing clip into the groove of panel A and slide it until there is no gap between the two panels.
- Screw the plastic bolt onto the fixing clip to secure the panels together once they have been adjusted to the appropriate length for your window.

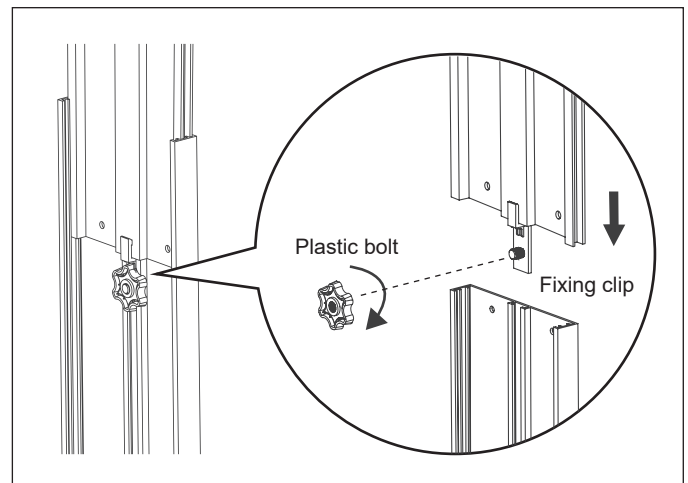

FIGURE 9

- If necessary, follow the above steps again to connect the other side of panel B to the extension panel (panel C). The total length of the panels will reach 157 cm (62 inches). If your window is longer than 157 cm (62 inches), you will have to improvise to fill the remaining space.

INSTALLATION GUIDE

f. Insert a fixing base at each end of your window panel assembly.

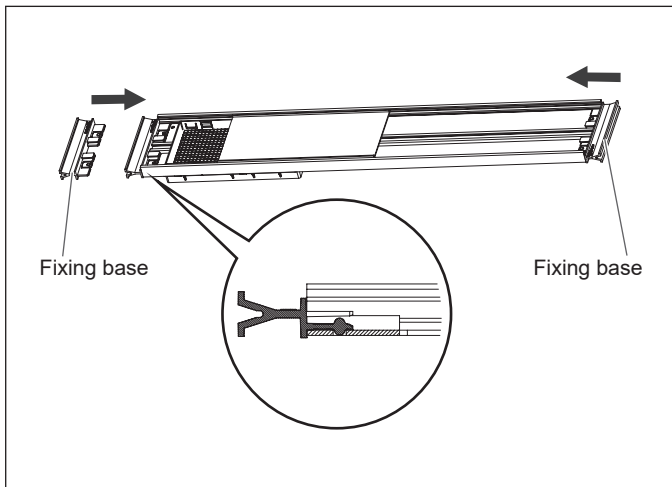

FIGURE 10

6. Insert the window panel assembly into the window frame and close the window sash against the panels.

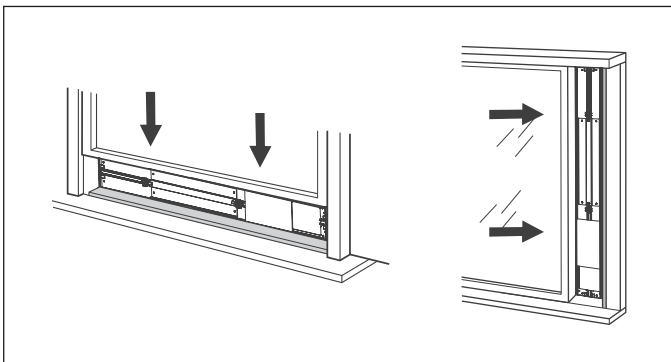

FIGURE 11

7. Fit foam seal A (non-adhesive) between the glass and the window sash to prevent air and insects from entering the room.

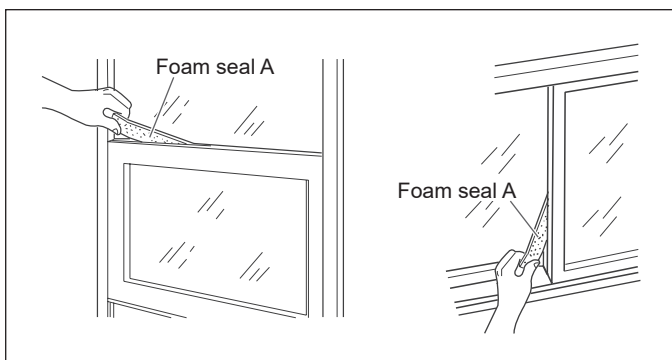

FIGURE 12

8. **Optional:** To prevent glass or window breakage, secure the window sash by fastening the supplied bracket to the window frame with a screw.

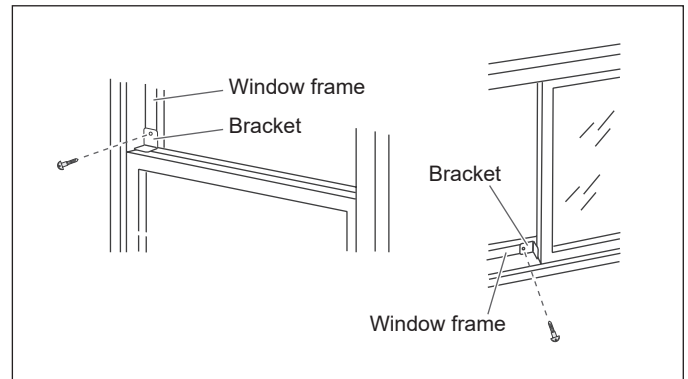

FIGURE 13

EXHAUST HOSE INSTALLATION

Please note that the use of the heat exhaust hose is **MANDATORY** for this portable air conditioner. This is because this GREE air conditioner (like all other air conditioners) must produce heat as a by-product of generating cooled air. If you do not connect the exhaust hose, your unit will vent this hot air into the room you are trying to cool.

1. Insert the exhaust fitting into one end of the hose and screw it on by turning it clockwise.
2. Insert the window fitting onto the second end of the hose and screw it on by turning it clockwise.

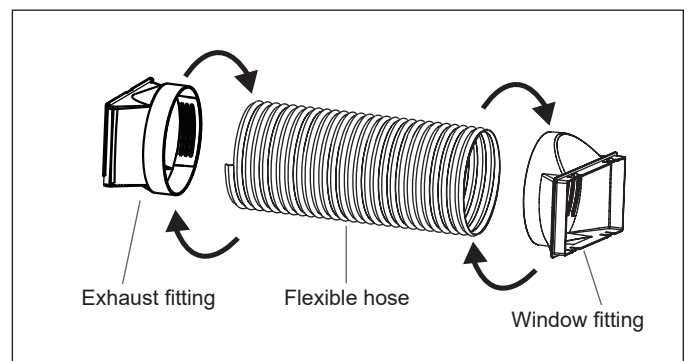

FIGURE 14

INSTALLATION GUIDE

3. Insert the end with the exhaust fitting onto the grooves on the bottom of the exhaust port on the back of the unit, then push until the fitting snaps into place on the clasp on the top.

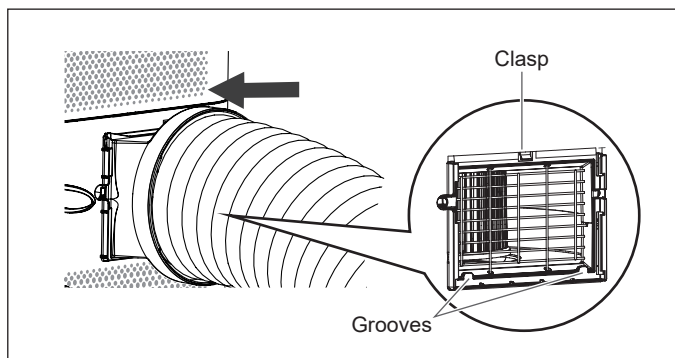

FIGURE 15

4. Snap the window fitting onto the main window panel, either horizontally or vertically depending on your installation.

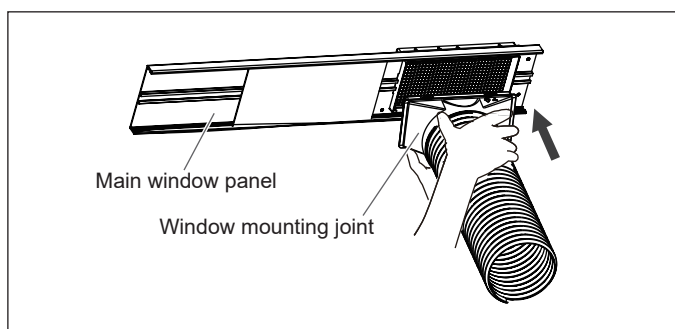

FIGURE 16

Tip: To improve the cooling efficiency of your air conditioner, the exhaust hose should be as short and straight as possible. We suggest the configuration shown in Figure 17.

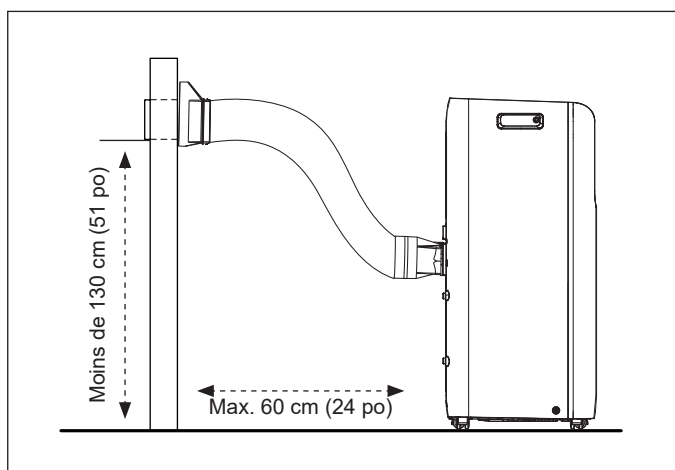

FIGURE 17

The user can adjust the installation method of the exhaust hose according to his needs. However, installation methods similar to those illustrated below are not permitted, as they may result in uneven heat removal and thus reduce the efficiency of the unit.

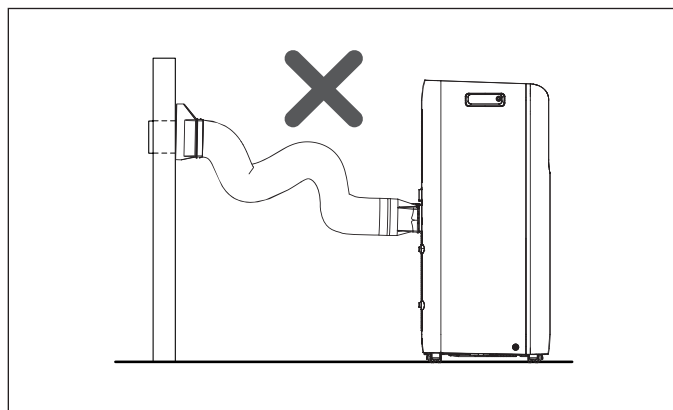

FIGURE 18

NOTES:

- The maximum length of the flexible hose is less than one meter. It is recommended to use the shortest possible length.
- When installing, the heat exhaust hose should be as horizontal as possible. Do not extend it by connecting it to other flexible hoses.

INSTALLATION OF POLYCARBONATE PANELS (OPTIONAL)

Refer to the installation sheet included with the polycarbonate window accessory kit for installation in a casement window.

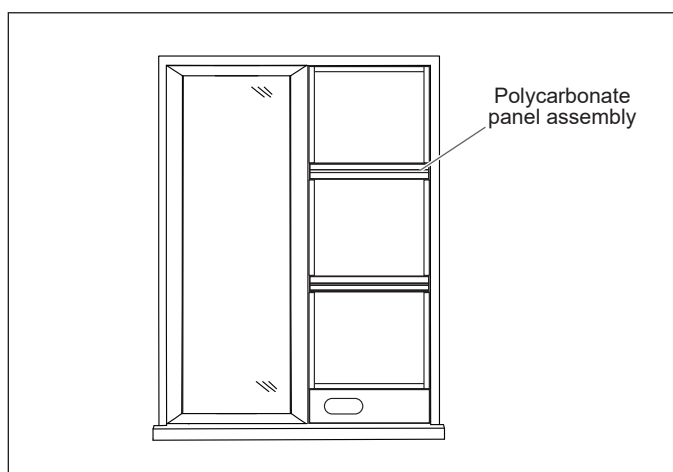
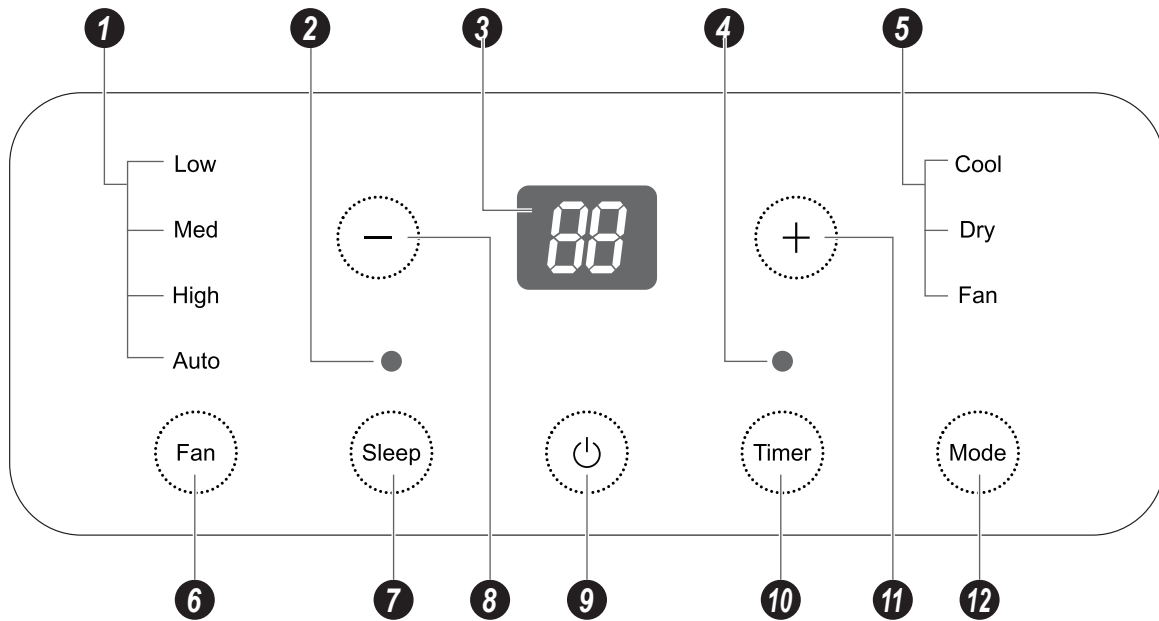

FIGURE 19

OPERATION GUIDE

CONTROL PANEL OVERVIEW



1	Fan Speeds	Low	Indicates that the air conditioner is operating in <i>Low</i> mode.
		Med	Indicates that the air conditioner is operating in <i>Med</i> mode.
		High	Indicates that the air conditioner is operating in <i>High</i> mode.
		Auto	Indicates that the air conditioner is operating in <i>Auto</i> mode.
2	Sleep	Indicates that the <i>Sleep</i> function is on.	
3	Display screen	On normal conditions, shows the room temperature.	
4	Timer	Indicates that a timer has been set.	
5	Modes	Cool	Indicates that the air conditioner is operating in <i>Cooling</i> mode.
		Dry	Indicates that the air conditioner is operating in <i>Drying</i> mode.
		Fan	Indicates that the air conditioner is operating in <i>Ventilation</i> mode.

6	Fan	Allows to select a fan speedsetting.
7	Sleep	Activates or deactivates the <i>Sleep</i> function.
8	—	Decreases the set temperature by 1° with each press.
9	⏻	Turns the air conditioner on or off.
10	Timer	Allows to set a timer.
11	+	Increases the set temperature by 1° with each press.
12	Mode	Allows to select an operation mode.

❗ **NOTE:** Buttons and indicators may differ from model to model, but their functionality remains the same. Some functions may not be available on all models.

OPERATION GUIDE

REMOTE CONTROL OVERVIEW

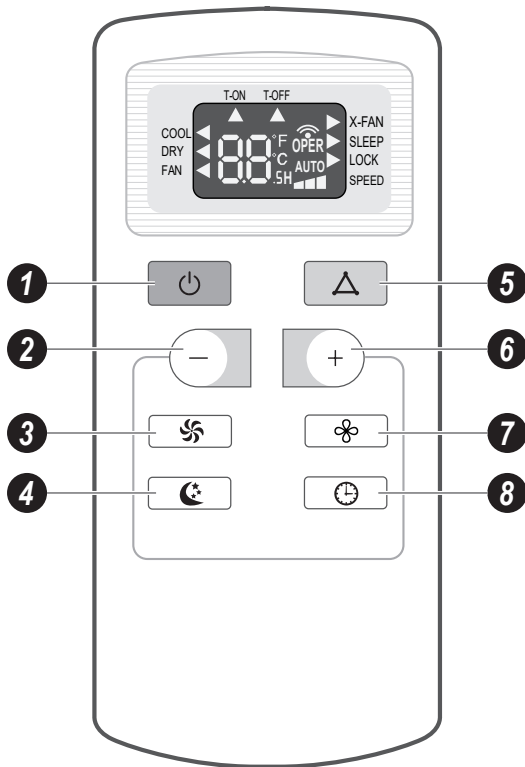

1		Turns the air conditioner on or off.
2		Decreases the set temperature by 1° with each press.
3		Allows to select a fan speed setting.
4		Activates or deactivates the <i>Sleep</i> function.
5		Allows to select an operation mode.
6		Increases the set temperature by 1° with each press.
7		Activates or deactivates the <i>X-Fan</i> function.
8		Allows to set a timer.

NOTE: This is a general purpose remote control which is used for a variety of air conditioners. Some functions may not be available on the model you have purchased. If you press the button of an unavailable function on the remote control, the unit will keep its original operating state.

BASIC OPERATING INSTRUCTIONS

BATTERY REPLACEMENT

1. Press-down the battery compartment cover on the back of the remote control, then slide it in the direction of the arrow as shown in the illustration.
2. Replace the depleted batteries with two new 1.5V AAA batteries. Make sure the positions of the “+” and “-” polarities match the markings inside the battery compartment.
3. Replace the battery compartment cover.

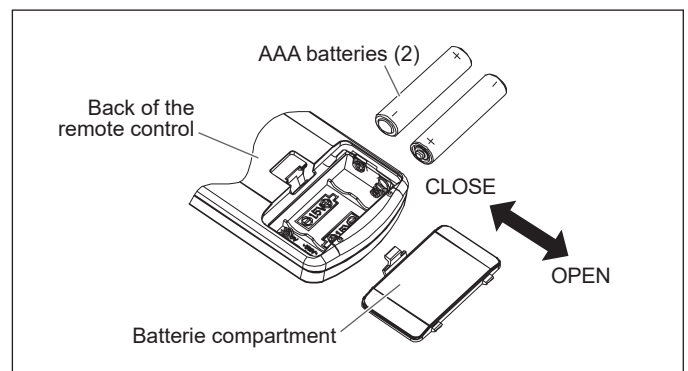

FIGURE 20

NOTES:

- Do not use rechargeable batteries.
- Replace with new batteries of the same brand when replacement is required.
- Do not dispose of used batteries with other domestic waste. Separate collection of such waste for special treatment is necessary.

OPERATION GUIDE

OPERATION RECOMMENDATIONS

⚠ WARNING:

- Operating Temperature Range:
Max. Cooling: DB/WB 35°C (95°F) / 24°C (75°F)
The operating temperature in cooling mode is 16°C (61°F) to 35°C (95°F).
- The appliance is intended for indoor use only.
- The electrical outlet must be within reach of the power cord.
- This appliance is intended for residential use only. Commercial use prohibited.
- Leave 30 cm (12 inches) clearance all around the air conditioner.
- Do not operate the unit in a humid environment.
- Keep the air inlet and outlet clear of obstructions.
- During operation, close doors and windows to improve cooling efficiency.
- Place the air conditioner on a smooth and flat surface for operation to avoid noise and vibration.
- This appliance is equipped with castors. The castors should be able to slide with no resistance on the floor.
- Do not tilt or overturn the air conditioner. The unit must be kept upright at all time.
- Avoid placing the unit in direct sunlight.

Control Panel:

- After turning on the power, the air conditioner will emit a beep. Following that, you may operate the unit using the control panel.
- When it is running, the air conditioner will make a beep after each press of a button on the control panel. Simultaneously, the corresponding indicator on the control panel will light up.
- When the air conditioner is turned off, the dual seven-segment display on the control panel does not show anything. When the air conditioner is turned on, the display will show the set temperature if the operating mode is set to *Cooling* mode. Temperature is not displayed in other modes.

Remote Control:

- Direct the remote control toward the signal receiver of the unit for optimal use.
- In order for the signal to be transmitted successfully, the distance between the remote control and the unit must be less than 8 meters (26 feet) and within a 60° angle (as seen in Figure 21).
- Make sure that there are no objects between the remote control and the signal receiver of the unit that could block the signal.
- Never leave the remote control exposed to sunlight.

- Keep the remote control at a distance greater than 1 meter (3 feet) from appliances or devices such as televisions, fluorescent lamps, wireless phones or other electrical appliances to avoid signal interference.
- When not using the remote control for an extended period of time, please remove the batteries so as not to wear them out needlessly.
- A blurry or blank display screen on the remote control may indicate a low battery level. In such a case, replace the batteries with new ones.

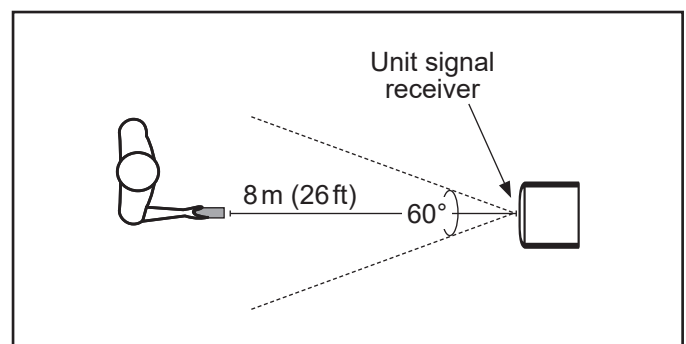

FIGURE 21

OPERATION GUIDE

FUNCTION DESCRIPTION AND SETTING

Note: Functions are the same when using the remote control and control panel, unless otherwise stated.

POWER ON/OFF

Allows the user to power the unit on or off.

Press the **POWER** (⏻) button to turn on the unit. Press again to turn off the unit.

TEMPERATURE SETTING

Allows the user to set the temperature in accordance with their needs.

Use the “+” and “-” buttons to increase or decrease the set temperature. Each press of either button increases or decreases the value by 1 °C (or 1 °F) to a maximum of 30 °C (or 86 °F) and to a minimum of 16 °C (or 61 °F). Once the temperature setting is complete, the temperature indicator on the unit will adjust to reflect the change.

OPERATION MODE SETTING

Allows the user to select an operation mode in accordance with their needs.

Press the **MODE** (Δ) button to select the desired operation mode. With each press of the button, the setting options cycle through in the following order:



Cooling Mode: In this operation mode, the unit will cool the room to the desired temperature as well as remove moisture from the air.

Drying Mode: In this operation mode, the unit will reduce the humidity in the air to make the room more comfortable. Fan speed is automatically set to *Low* speed and cannot be adjusted.

Ventilation Mode: In this operation mode, the unit will blow uncooled/unheated air. Set temperature cannot be adjusted.

FAN SPEED SETTING

Allows the user to select a fan speed in accordance with their needs.

Press the **FAN** (🌀) button to select the desired fan speed. With each press of the button, the setting options cycle through in the following order:

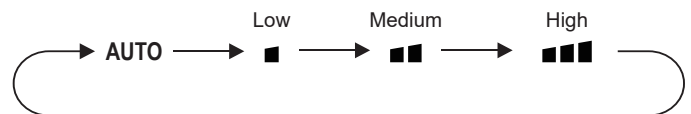

TIMER SETTING

SWITCH-ON TIMER

Allows the user to set a switch-on timer. The unit will switch on once the start delay has been reached.

While the unit is turned off, press the **TIMER** (🕒) button. The words “T-ON” and “H” will begin to flash on the display screen of the remote control. Use the “+” and “-” buttons to set the desired time. Each press of either button increases or decreases the time by 30 minutes. Holding either button down for more than 2 seconds will cause the hours to scroll up or down more quickly. When done, press the **TIMER** (🕒) button to confirm the timer setting. The words “T-ON” and “H” will stop blinking on the display screen of the remote control.

If there is no button press for more than 5 seconds during time setting, the unit will cancel out of it.

To cancel a switch-on timer that has been set, press the **TIMER** (🕒) button once

Note: Time setting range is 0.5 to 24 hours.

SWITCH-OFF TIMER

Allows the user to set a switch-off timer. The unit will stop running when the set operating time has elapsed.

While the unit is turned on, press the **TIMER** (🕒) button. The symbols “T-OFF” and “H” will begin to flash on the display screen of the remote control. Use the “+” and “-” buttons to set the desired time. Each press of either button increases or decreases the time by 30 minutes. Holding either button down for more than 2 seconds will

OPERATION GUIDE

cause the hours to scroll up or down more quickly. When done, press the **TIMER** (🕒) button to confirm the timer setting. The symbols “T-OFF” and “H” will stop blinking on the display screen of the remote control.

If there is no button pressed for more than 5 seconds during time setting, time setting will be cancelled.

To cancel a switch-off timer that has been set, press the **TIMER** (🕒) button once

Note: Time setting range is 0.5 to 24 hours.

X-FAN FUNCTION

Allows the indoor fan to continue running at low speed for a period of time after the air conditioner is turned off to remove residual water in the air duct.

Press the **X-FAN** (🌀) on the remote control to activate the *X-Fan* function. Press the button again to deactivate the function.

Note: This function is only available in *Cooling* or *Drying* mode.

Note: While the fan is operating under *X-Fan* mode, if the **X-FAN** (🌀) is pressed, the indoor fan will stop immediately.

SLEEP FUNCTION

Allows the unit to use a preset sleep curve to maintain the most comfortable temperature for you during the night.

Press the **SLEEP** (🌙) button to activate *Sleep* mode. After activation, the preset will increase the temperature by 1°C (2°F) over the next hour, then by 2°C (4°F) over the next 2 hours, after which the unit will maintain this temperature until the function is deactivated. Press the button again to turn off *Sleep* mode.

Note: This function is only available in *Cooling* mode.

LIGHTS ON/OFF

Allows the user to turn on and off the lights of the air conditioner.

Press the **FAN** (🌀) and “+” buttons simultaneously for 3 seconds on the remote control to turn the lights on or off. The default setting after being powered on is for the lights to be on.

TEMPERATURE UNIT CHANGEOVER

Allows the user to select between Celsius or Fahrenheit as the temperature unit for the display.

While the unit is turned off, press the **MODE** (Δ) and “-” buttons simultaneously to select Celsius as the desired temperature measuring unit for the display. Press the same buttons simultaneously again to select Fahrenheit.

CONTROLS LOCK

Allows the user to lock the remote control buttons to prevent a small child or others from changing the settings.

Press the “+” and “-” buttons on the remote control simultaneously to activate the lock. The “LOCK” indicator on the remote control display will light up. Once activated, the remote control buttons will become inoperative. If you attempt to use the controls while the remote is locked, no signal will be sent to the unit. Simultaneously press the same buttons again to disable the lock.

AIRFLOW ADJUSTEMENT

Before using the unit, push the marking “PUSH” on the airflow deflectors with your finger to open them. To improve comfort, we suggest that you open the airflow deflectors to their maximum position.

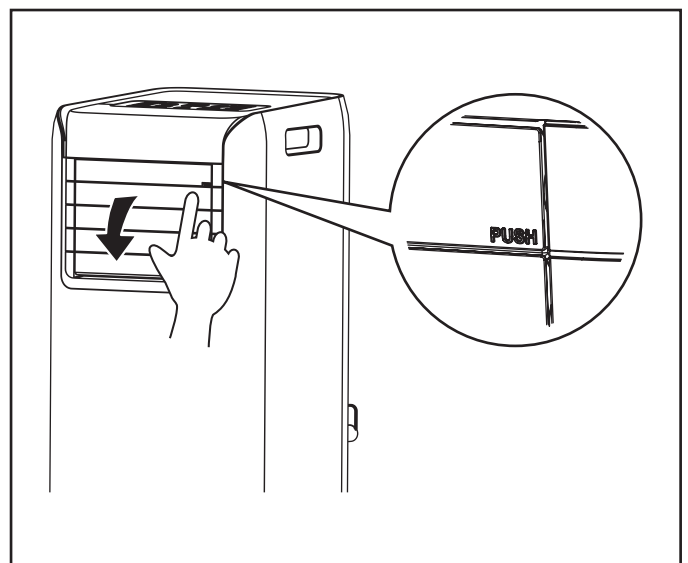

FIGURE 22

MAINTENANCE

⚠ WARNING :

- Turn off the air conditioner and unplug the power cord from the outlet before cleaning to avoid electric shock.
- Do NOT wash the air conditioner with water to avoid electric shock.
- Do NOT use harsh detergents to clean the air conditioner.
- Do not use liquid or corrosive detergent to clean the unit and do not splash the unit with water or any other liquid, otherwise it may damage the plastic components or even cause electric shock.

CLEANING THE CASING

If there is dust on the surface of the outer case, please use a soft cloth to wipe it. You might need to use mild detergent to do the cleaning.

Avoid using harsh cleaning products or abrasives. Such products can cause premature deterioration and/or yellowing of the surface finish of the air conditioner.

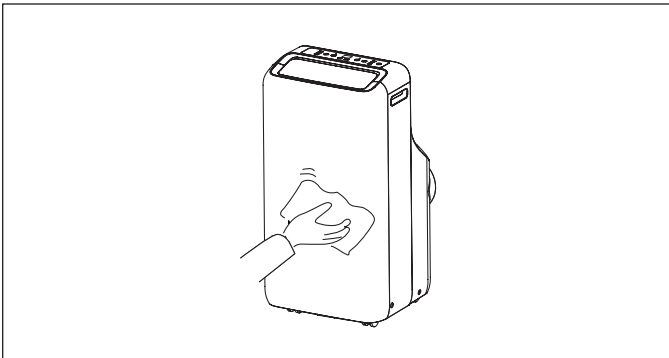

FIGURE 23

CLEANING THE AIR FILTER

Clean the air filter once every two weeks in order to prevent dust from clogging the appliance and reducing its effectiveness.

1. Open the filter access by pulling on the clasp on the right side, then remove the filter by pulling it towards you.

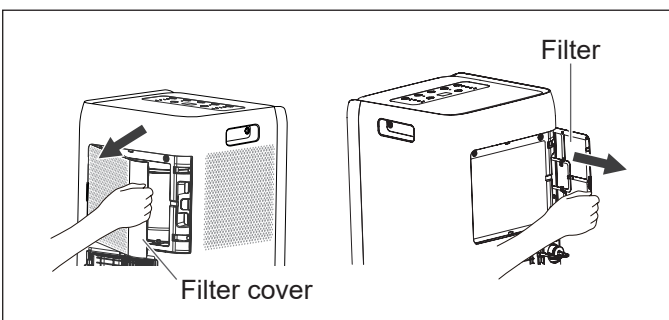

FIGURE 24

2. Clean the dust filter with a clean, damp cloth or rag. If the filter is very dirty, soak in warm water (40 °C / 104 °F) with mild soap. A soft bristle brush may help remove some dirt if needed.

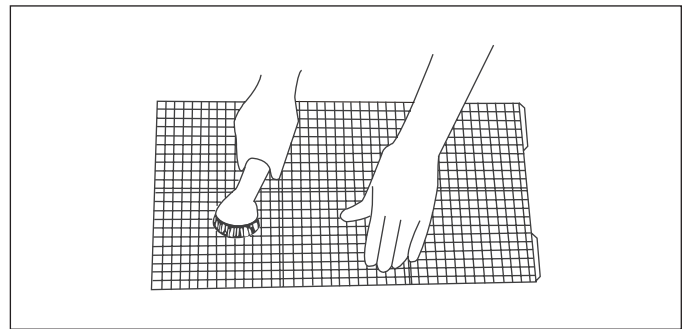

FIGURE 25

3. Leave out to dry. Do not attempt to dry the filter with a hairdryer or other heating elements as this may deform or ignite the filter.
4. After the filter is cleaned and dried, reinstall it.

ⓘ NOTES :

- Do not touch the metal fins in the air conditioner after removing the filter as they may cause personal injury.
- Never operate the air conditioner without a filter. The inside of the unit will become clogged, which could result in a drop in performance or even damage the internal components.

CLEANING THE EXHAUST HOSE

Detach the heat exhaust hose from the air conditioner, clean it, dry it, and then reinstall it.

For instructions on how to install and remove the hose, refer to the **Installation Guide** section of the manual.

MAINTENANCE

WATER DRAINAGE

This GREE portable air conditioner comes with an auto-evaporation system. The unit automatically evaporates the condensation. There is no need to empty the water except in humid conditions. When the appliance needs to be drained, an alarm will beep 8 times and the display panel will show an H8 malfunction code.

Manual Drainage:

For manual drainage, follow these steps:

1. Turn off the unit and pull out the power cord from the wall socket.
2. Place a container under the drain port or move it to a floor drain or other suitable place for discharging water. Please keep the unit horizontal so water does not spill.
3. Remove the rubber plug from the drain port to let the collected water pour out.
4. Once the collected water has been completely drained, put the rubber plug back in place.

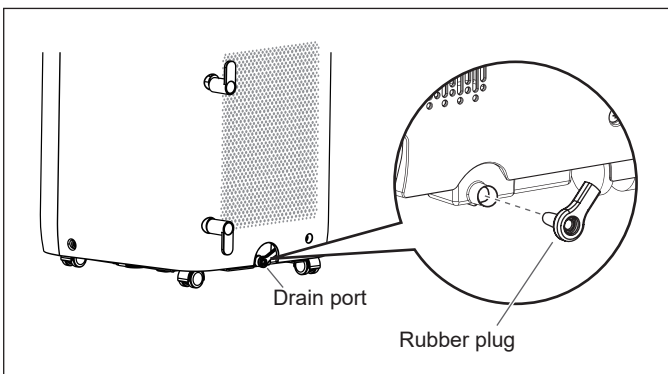

FIGURE 26

Optional: You may use a drain hose (not supplied) with an inner diameter of 13 mm (1/2 inch) to facilitate the drainage process.

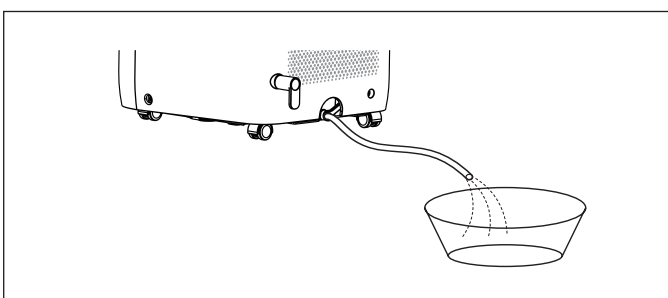

FIGURE 27

Continuous Drainage:

1. Remove the drain cap by turning it counterclockwise, then remove the rubber stopper from the spout.

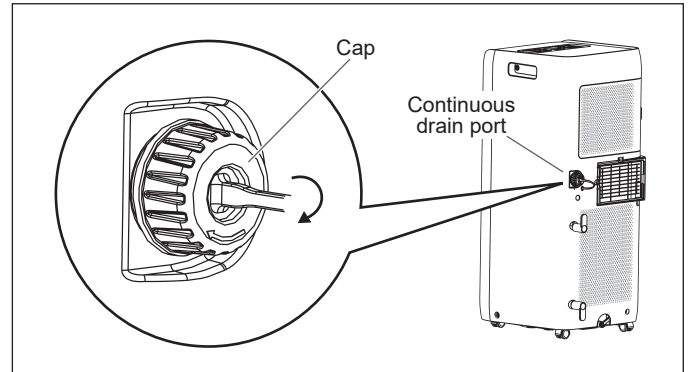

FIGURE 28

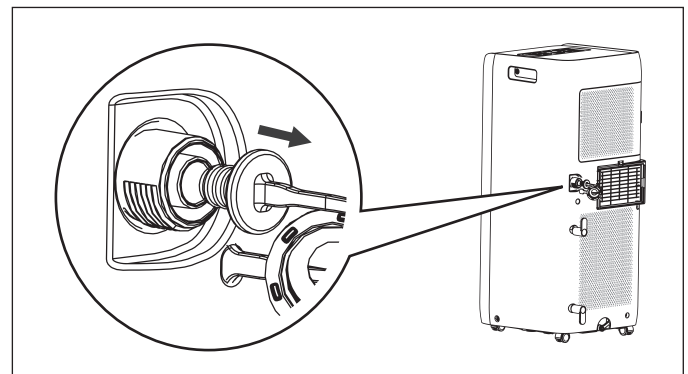

FIGURE 29

2. Insert a drain hose (not supplied) with an inner diameter of 13 mm (1/2 inch) into the continuous drain port.
3. Lead the hose to a floor drain, container or other suitable location to drain water.

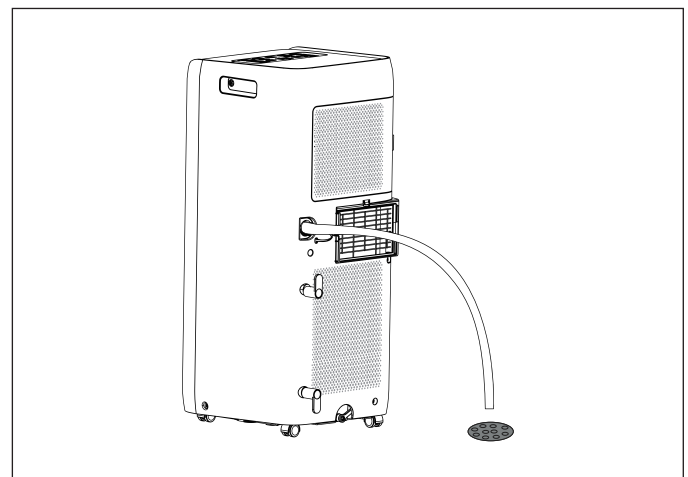

FIGURE 30

MAINTENANCE

⚠ WARNING :

When using the continuous drain option from the center port, place the unit on a flat surface and make sure the hose is unobstructed and pointing down. If you place the unit on an uneven surface or install the hose improperly, water may accumulate in the chassis and cause the unit to shut down.

If this should occur, drain the water from the chassis and make sure the unit and hose are properly installed and positioned.

APPLIANCE DISPOSAL

- Many packing materials are recyclable materials. Please dispose them in appropriate recycling unit.
- Electrical products should be properly disposed. If you want to throw away the air conditioner, please contact your local authority or retailer for the correct disposal method.

PRE-SEASON CHECKLIST

1. Check if the air inlets and outlets are clear.
2. Check if the power plug and socket are in good condition.
3. Check if the filter is clean.
4. Check if batteries are properly installed in the remote control.
5. Check if the joints, window kit and exhaust hose are properly installed.
6. Check if the exhaust hose is in good condition.

LONG TERM STORAGE

If you do not intend to use the air conditioner during the off-season or for any extended period of time, please follow these steps to ensure the unit remains in good working condition :

1. To ensure there is no accumulated water left in the appliance, set the temperature at 30 °C (86 °F) and let the unit run for half a day to dry the inside completely.
2. Turn off the air conditioner and disconnect the power cord.
3. Disassemble the exhaust hose and window kit.
4. Clean the dust filter then put it back into the unit.
5. Clean the outer case of the appliance thoroughly.
6. Take the batteries out of the remote control.
7. Cover the air conditioner and all its components with a plastic bag. Store the appliance in a cool, dry place, away from direct sunlight, extreme temperatures, and excessive dust.

TROUBLESHOOTING

COMMON ISSUES

If your appliance appears defective, please check the possible explanations for your situation in the table below, it may be that a simple solution can help solve the problem. If the problem persists, please call our Service Center at **1 800 686-2175** for assistance.

SITUATION	POSSIBLE CAUSES	SOLUTIONS
The air conditioner does not work.	There is no electricity.	Connect the unit to a socket with power, or if there is a power outage, wait for electricity to be restored.
	The power plug has loosen from the outlet.	Firmly push the plug into the power outlet.
	The circuit breaker is tripped or the fuse is blown.	Replace the fuse or reset the circuit breaker. Make sure that there are no other appliances on the same circuit.
	The unit is immediately restarted after having being shut off or the operation mode has been changed.	The compressor shuts off due to changing modes. Wait 5 minutes.
The efficiency of the cooling (or heating) is very poor.	The set temperature is too high.	In <i>Cooling</i> mode, adjust the set temperature so that it is below the ambient temperature.
	When trying to cool, the room temperature is below 16°C (60°F).	Cooling may not occur if the room temperature is below 16°C (60°F).
	There is direct sunlight in the room.	Pull the curtain or close the blinds to prevent sunlight from heating the room.
	Doors or windows are opened.	Close doors and windows.
	There are a lot of people in the room.	Wait for people to leave to see if the room cools down.
	There are sources of heat present in the room.	Turn off or remove any heat sources that could be counteracting the cooling efficiency of the unit.
	The filter is dirty.	Clean or replace the air filter.
The air vents are obstructed.	The air vents are obstructed.	Clear objects or furniture that could be blocking the vents of the unit.
	There are cracking sounds coming from the unit.	The unit has recently been turned on or turned off.
There are odd sounds during operation.	The unit is potentially interfered with by a thunder storm, radio signals, etc.	Disconnect the power, put the power back on, and then turn the unit back on.
There is a sound of flowing liquid emitting from the unit.	The unit has recently been turned on or turned off.	This occurrence is normal. It is the flowing sound of refrigerant inside the air conditioner.
The remote control does not work.	The distance between the appliance and the remote control is too great.	Get closer to the unit so the remote control signal can reach the main unit's receiver.
	The remote control is not properly aligned with the main unit's signal receiver.	Make sure to be facing the unit when pressing keys on the remote control.
	There is a fluorescent lamp in the room.	Turn off the fluorescent lamp and try again, or move closer to the main unit.
	There are objects between the remote control and the main unit.	Remove any obstacles that could be blocking the signal.
	The main unit is significantly interfered with due to static pressure, unstable voltage, etc.	Unplug the power cord, wait for about 3 minutes, reconnect the plug, then turn on the unit.

TROUBLESHOOTING

	The batteries are depleted.	Replace with new batteries.
	The desired temperature exceeds the temperature range.	The temperature range is 16 – 30 °C (61 – 86 °F).
There is an unpleasant smell emanating from the appliance.	There is a person smoking a cigarette close by, or a garbage bin has been left opened in proximity to the appliance, etc., indoor or outdoor.	Odours can be caught by the appliance and spread with the airflow. Eliminate the source of the odour.

■ MALFUNCTION CODES

If any of the following malfunction codes appear on the display screen of the unit, please call Customer Service at **1 800 686-2175** for assistance.

CODE	DESCRIPTION	SOLUTIONS
F0	Refrigerant leakage	Please contact our Service Center.
F1	Ambient temperature sensor malfunction	
F2	Evaporator temperature sensor malfunction	
F4	Exhaust hose temperature sensor malfunction	
H3, E8	Overload malfunction	<ol style="list-style-type: none"> 1. Check if the unit is under a high-temperature and highhumidityenvironment;restart the unit after the ambient temperature drops to 35°C (95°F) below. 2. Check if the evaporator and condenser are blocked. If the malfunction codes still occur, please contact our Service Center for help.
H8	Chassis filled of water	Please refer to the Water Drainage section on page 20. If “H8” persists, please contact our Service Center.

⚠ WARNING :

- When any of the following conditions occur, turn off the air conditioner and disconnect the power supply immediately, then contact your local dealer or service center for repairs.
 1. The power cord is overheated or damaged.
 2. There is abnormal sounds during operation.
 3. The circuit breaker trips frequently.
 4. The air conditioner gives off a burning smell.
 5. The air conditioner is leaking.
- Do not repair the air conditioner yourself. You may expose yourself to electric shock or damage the equipment.

SERVICE GUIDE

■ SPECIAL SAFETY PRECAUTIONS FOR FLAMMABLE REFRIGERANTS

Aptitude requirement for service technician (repairs should be done only by specialists).

- a. Any person who is involved with working on or breaking into a refrigerant circuit should hold a current valid certificate from an industry-accredited assessment authority, which authorises their competence to handle refrigerants safely in accordance with an industry recognised assessment specification.
- b. Servicing shall only be performed as recommended by the equipment manufacturer. Maintenance and repair requiring the assistance of other skilled personnel shall be carried out under the supervision of the person competent in the use of flammable refrigerants.

TRANSPORT OF EQUIPMENT CONTAINING FLAMMABLE REFRIGERANTS

In compliance with transport regulations.

MARKING OF EQUIPMENT USING SIGNS

In compliance with local regulations.

DISPOSAL OF EQUIPMENT USING FLAMMABLE REFRIGERANTS

In compliance with national regulations.

STORAGE OF EQUIPMENT/APPLIANCES

Equipment should be stored in accordance with the manufacturer's instructions.

STORAGE OF PACKED (UNSOLD) EQUIPMENT

Storage must provide protection to prevent mechanical damage to the equipment inside the package that could cause the refrigerant charge to leak.

The maximum number of pieces of equipment permitted to be stored together is determined by local regulations.

INFORMATION ON SERVICING

SITE INSPECTIONS

- Prior to beginning work on systems containing flammable refrigerant, safety inspections are required to ensure that the risk of ignition is minimized.
- For repair to the refrigerant system, the following precautions must be observed before performing any work on the system.

WORK PROCEDURE

- Work shall be undertaken under a controlled procedure so as to minimise the risk of a flammable gas or vapour being present while the work is being performed.

GENERAL WORK AREA

- All maintenance staff and others working in the local area shall be instructed on the nature of work being carried out. Work in confined spaces shall be avoided.
- The area around the workspace shall be sectioned off. Ensure that the conditions within the area have been made safe by control of flammable material.

CHECKING FOR THE PRESENCE OF REFRIGERANT

- The area shall be checked with an appropriate refrigerant detector prior to and during work, to ensure the technician is aware of potentially flammable atmospheres.
- Ensure that the leak detection equipment being used is suitable for use with flammable refrigerants, i.e. non-sparking, adequately sealed or intrinsically safe.

PRESENCE OF FIRE EXTINGUISHER

- If any hot work is to be conducted on the refrigeration equipment or any associated parts, appropriate fire extinguishing equipment shall be available to hand.
- Have a dry powder or CO₂ fire extinguisher adjacent to the charging area.

NO IGNITION SOURCES

- No person carrying out work in relation to a refrigeration system which involves exposing any pipe work that contains or has contained flammable refrigerant shall use any sources of ignition in such a manner that it may lead to the risk of fire or explosion.
- All possible ignition sources, including cigarette smoking, should be kept sufficiently far away from the site of installation, repairing, removing and disposal, during which flammable refrigerant can possibly be released to the surrounding space.
- Prior to work taking place, the area around the equipment is to be surveyed to make sure that there are no flammable hazards or ignition risks. "No Smoking" signs shall be displayed.

VENTILATED AREA

- Ensure that the area is in the open or that it is adequately ventilated before breaking into the system

SERVICE GUIDE

or conducting any hot work.

- A degree of ventilation shall continue during the period that the work is carried out.
- The ventilation should safely disperse any released refrigerant and preferably expel it externally into the atmosphere.

INSPECTIONS OF REFRIGERATION EQUIPMENT

- Where electrical components are being changed, they shall be fit for the purpose and to the correct specification.
- At all times the manufacturer's maintenance and service guidelines shall be followed. If in doubt consult the manufacturer's technical department for assistance.
- The following checks shall be applied to installations using flammable refrigerants:
 - The charge size is in accordance with the room size within which the refrigerant containing parts are installed;
 - The ventilation machinery and outlets are operating adequately and are not obstructed;
 - If an indirect refrigerating circuit is being used, the secondary circuit shall be checked for the presence of refrigerant;
 - Marking to the equipment continues to be visible and legible. Markings and signs that are illegible shall be corrected;
 - Refrigeration pipe or components are installed in a position where they are unlikely to be exposed to any substance which may corrode refrigerant containing components, unless the components are constructed of materials which are inherently resistant to being corroded or are suitably protected against being so corroded.

CHECKS TO ELECTRICAL DEVICES

- Repair and maintenance to electrical components shall include initial safety checks and component inspection procedures.
- If a fault exists that could compromise safety, then no electrical supply shall be connected to the circuit until it is satisfactorily dealt with.
- If the fault cannot be corrected immediately but it is necessary to continue operation, an adequate temporary solution shall be used.
- This shall be reported to the owner of the equipment so all parties are advised.
- Initial safety checks shall include:
 - That capacitors are discharged: this shall be done in a safe manner to avoid possibility of sparking;
 - That there no live electrical components and

wiring are exposed while charging, recovering or purging the system;

- That there is continuity of earth bonding.

REPAIRS TO SEALED COMPONENTS

- During repairs to sealed components, all electrical supplies shall be disconnected from the equipment being worked upon prior to any removal of sealed covers, etc.
- If it is absolutely necessary to have an electrical supply to equipment during servicing, then a permanently operating form of leak detection shall be located at the most critical point to warn of a potentially hazardous situation.
- Particular attention shall be paid to the following to ensure that by working on electrical components, the casing is not altered in such a way that the level of protection is affected.
 - This shall include damage to cables, excessive number of connections, terminals not made to original specification, damage to seals, incorrect fitting of glands, etc.
 - Ensure that apparatus is mounted securely.
 - Ensure that seals or sealing materials have not degraded such that they no longer serve the purpose of preventing the ingress of flammable atmospheres.
 - Replacement parts shall be in accordance with the manufacturer's specifications.

Note: The use of silicon sealant may inhibit the effectiveness of some types of leak detection equipment. Intrinsically safe components do not have to be isolated prior to working on them.

REPAIR TO INTRINSICALLY SAFE COMPONENTS

- Do not apply any permanent inductive or capacitance loads to the circuit without ensuring that this will not exceed the permissible voltage and current permitted for the equipment in use.
- Intrinsically safe components are the only types that can be worked on while live in the presence of a flammable atmosphere. The test apparatus shall be at the correct rating.
- Replace components only with parts specified by the manufacturer.
- Other parts may result in the ignition of refrigerant in the atmosphere from a leak.

CABLING

- Check that cabling will not be subject to wear, corrosion, excessive pressure, vibration, sharp edges or any other adverse environmental effects.

SERVICE GUIDE

- The check shall also take into account the effects of aging or continual vibration from sources such as compressors or fans.

DETECTION OF FLAMMABLE REFRIGERANTS

- Under no circumstances shall potential sources of ignition be used in the searching for or detection of refrigerant leaks.
- A halide torch (or any other detector using a naked flame) shall not be used.

LEAK DETECTION METHODS

The following leak detection methods are deemed acceptable for systems containing flammable refrigerants:

- Electronic leak detectors shall be used to detect flammable refrigerants, but the sensitivity may not be adequate, or may need re-calibration (detection equipment shall be calibrated in a refrigerant-free area).
- Ensure that the detector is not a potential source of ignition and is suitable for the refrigerant used.
- Leak detection equipment shall be set at a percentage of the LFL of the refrigerant and shall be calibrated to the refrigerant employed and the appropriate percentage of gas (25% maximum) is confirmed.
- Leak detection fluids are suitable for use with most refrigerants but the use of detergents containing chlorine shall be avoided as the chlorine may react with the refrigerant and corrode the copper pipe-work.
- If a leak is suspected, all naked flames shall be removed/ extinguished.
- If a leakage of refrigerant is found which requires brazing, all of the refrigerant shall be recovered from the system, or isolated (by means of shut off valves) in a part of the system remote from the leak.
- Oxygen free nitrogen (OFN) shall then be purged through the system both before and during the brazing process.

REMOVAL AND EVACUATION

- When breaking into the refrigerant circuit to make repairs – or for any other purpose – conventional procedures shall be used. However, for flammable refrigerants it is important that the best practice is followed since flammability is a consideration. Opening of the refrigeration systems shall not be done by brazing.
- The following procedure shall be adhered to:
 - Remove refrigerant;

- Purge the circuit with inert gas;
- Evacuate;
- Purge again with inert gas;
- Open the circuit by cutting or brazing.

- The refrigerant charge shall be recovered into the correct recovery cylinders.
- The system shall be “flushed” with OFN to render the unit safe.
- This process may need to be repeated several times.
- Compressed air or oxygen shall not be used for this task.
- Flushing shall be achieved by breaking the vacuum in the system with OFN and continuing to fill until the working pressure is achieved, then venting to atmosphere, and finally pulling down to a vacuum.
- This process shall be repeated until no refrigerant is within the system. When the final OFN charge is used, the system shall be vented down to atmospheric pressure to enable work to take place.
- This operation is absolutely vital if brazing operations on the pipe-work are to take place.
- Ensure that the outlet for the vacuum pump is not close to any ignition sources and there is ventilation available.

CHARGING PROCEDURES

- In addition to conventional charging procedures, the following requirements shall be followed:
 - Ensure that contamination of different refrigerants does not occur when using charging equipment.
 - Hoses or lines shall be as short as possible to minimise the amount of refrigerant contained in them.
 - Cylinders shall be kept upright.
 - Ensure that the refrigeration system is earthed prior to charging the system with refrigerant.
 - Label the system when charging is complete (if not already).
 - Extreme care shall be taken not to overfill the refrigeration system.
- Prior to recharging the system it shall be pressure tested with OFN.
- The system shall be leak tested on completion of charging but prior to commissioning.
- A follow up leak test shall be carried out prior to leaving the site.

SERVICE GUIDE

DECOMMISSIONING

- Before carrying out this procedure, it is essential that the technician is completely familiar with the equipment and all its detail.
- It is recommended good practice that all refrigerants are recovered safely.
- Prior to the task being carried out, an oil and refrigerant sample shall be taken in case analysis is required prior to re-use of reclaimed refrigerant. It is essential that electrical power is available before the task is commenced.
 - a) Become familiar with the equipment and its operation.
 - b) Isolate system electrically.
 - c) Before attempting the procedure ensure that:
 - Mechanical handling equipment is available, if required, for handling refrigerant cylinders;
 - All personal protective equipment is available and being used correctly;
 - The recovery process is supervised at all times by a competent person;
 - Recovery equipment and cylinders conform to the appropriate standards.
 - d) Pump down refrigerant system, if possible.
 - e) If a vacuum is not possible, make a manifold so that refrigerant can be removed from various parts of the system.
 - f) Make sure that cylinder is situated on the scales before recovery takes place.
 - g) Start the recovery machine and operate in accordance with manufacturer's instructions.
 - h) Do not overfill cylinders (no more than 80% volume liquid charge).
 - i) Do not exceed the maximum working pressure of the cylinder, even temporarily.
 - j) When the cylinders have been filled correctly and the process completed, make sure that the cylinders and the equipment are removed from site promptly and all isolation valves on the equipment are closed off.
 - k) Recovered refrigerant shall not be charged into another refrigeration system unless it has been cleaned and checked.

LABELLING

- Equipment shall be labelled stating that it has been de-commissioned and emptied of refrigerant.
- The label shall be dated and signed.
- Ensure that there are labels on the equipment stating the equipment contains flammable refrigerant.

REFRIGERANT RECOVERY

- When removing refrigerant from a system, either for servicing or decommissioning, it is recommended good practice that all refrigerants are removed safely.
- When transferring refrigerant into cylinders, ensure that only appropriate refrigerant recovery cylinders are employed.
- Ensure that the correct number of cylinders for holding the total system charge is available.
- All cylinders to be used are designated for the recovered refrigerant and labelled for that refrigerant (i.e. special cylinders for the recovery of refrigerant).
- Cylinders shall be complete with pressure relief valve and associated shut-off valves in good working order.
- Empty recovery cylinders are evacuated and, if possible, cooled before recovery occurs.
- The recovery equipment shall be in good working order with a set of instructions concerning the equipment that is at hand and shall be suitable for the recovery of flammable refrigerants.
- In addition, a set of calibrated weighing scales shall be available and in good working order.
- Hoses shall be complete with leak-free disconnect couplings and in good condition.
- Before using the recovery machine, check that it is in satisfactory working order, has been properly maintained and that any associated electrical components are sealed to prevent ignition in the event of a refrigerant release.
- Consult manufacturer if in doubt.
- The recovered refrigerant shall be returned to the refrigerant supplier in the correct recovery cylinder, and the relevant Waste Transfer Note arranged.
- Do not mix refrigerants in recovery units and especially not in cylinders.
- If compressors or compressor oils are to be removed, ensure that they have been evacuated to an acceptable level to make certain that flammable refrigerant does not remain within the lubricant.
- The evacuation process shall be carried out prior to returning the compressor to the suppliers.
- Only electric heating to the compressor body shall be employed to accelerate this process.
- When oil is drained from a system, it shall be carried out safely.

SERVICE GUIDE

ELECTRIC DIAGRAM

Electrical diagrams are subject to change without notice. Please refer to the one on the unit.

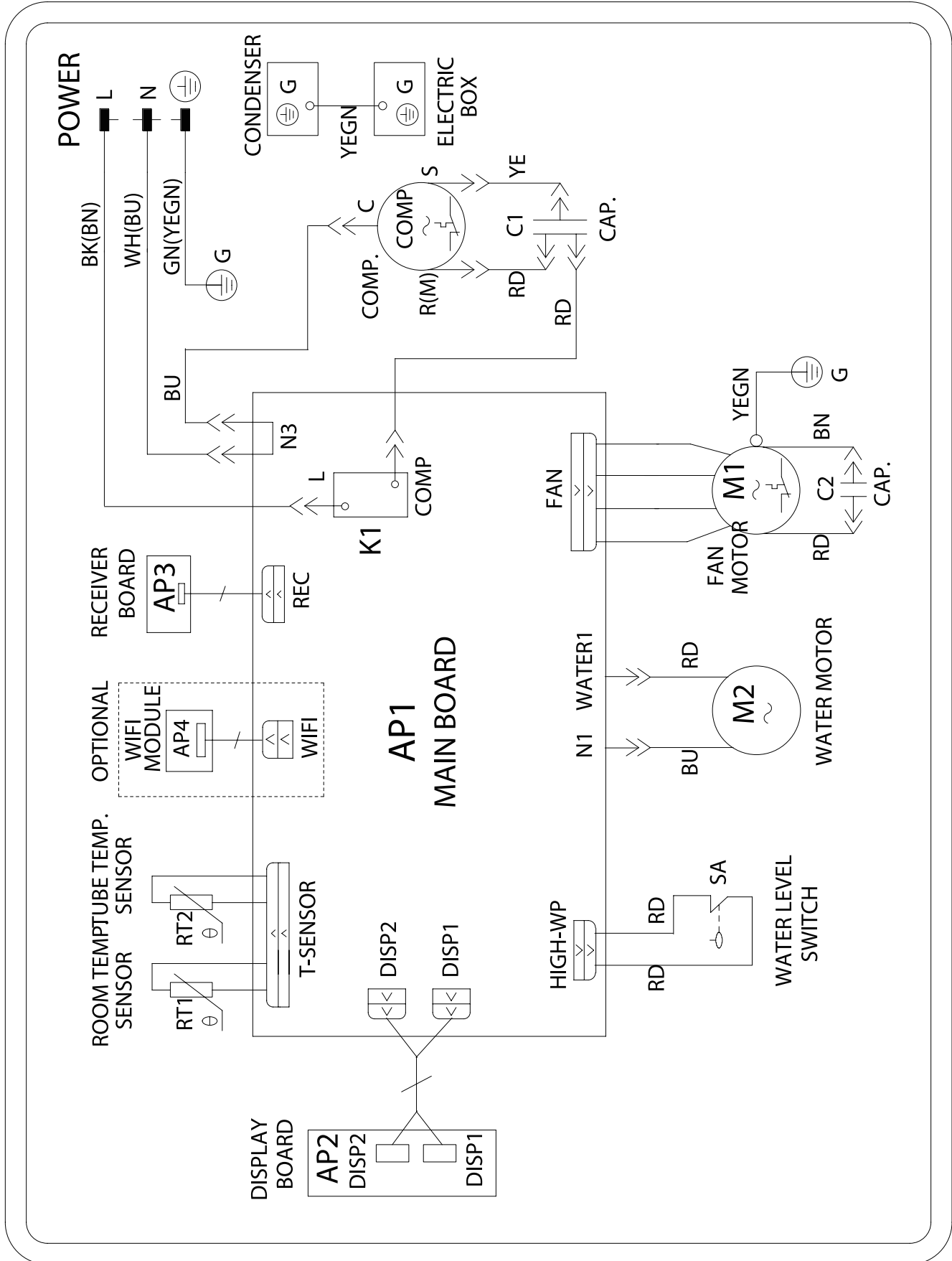

WARRANTY

■ WARRANTY COVERAGE

This product is covered by a limited warranty against manufacturing defects in materials and workmanship, if used for the applications specified in this manual, for a period of **ONE (1) years on parts and FIVE (5) on the compressor** from the date of original purchase in Canada.

During the warranty period, if the appliance fails under normal use, GREE Canada will, at its option, either repair the unit or replace it, free of charge, within a reasonable period of time after the product is returned.

As a condition to any warranty service obligation, the customer must present this warranty certificate along with the proof of purchase.

■ ITEMS NOT COVERED

- Damage, accidental or otherwise, to the appliance that is not caused by materials or workmanship defect.
- Damage caused by misuse, tampering or failure to follow the operating and maintenance instructions provided in this manual.
- Damage to the finish of the unit casing or to other outer features caused by wear.
- The filters.
- Damage caused by repairs or modifications to the appliance made by any person not duly authorized by GREE Canada.
- Insurance and freight costs for the warranty service.

■ LIMITED WARRANTY STATEMENT

LIMITATIONS OF WARRANTIES: ALL IMPLIED WARRANTIES AND/OR CONDITIONS (INCLUDING IMPLIED WARRANTIES OR CONDITIONS OF MERCHANTABILITY AND FITNESS FOR A PARTICULAR USE OR PURPOSE) ARE LIMITED TO THE DURATION OF THIS LIMITED WARRANTY. THE EXPRESS WARRANTIES MADE IN THIS WARRANTY ARE EXCLUSIVE AND MAY NOT BE ALTERED, ENLARGED, OR CHANGED BY A DISTRIBUTORS, DEALER, OR OTHER PERSON, WHATSOEVER.

Keep this manual along with your proof of purchase in a safe place for future reference. You must provide proof of purchase for warranty service.

WARRANTY

■ OWNER'S RESPONSIBILITIES

The owner is fully responsible for the following :

1. All services or repairs not covered by this agreement.
2. Checking and replacing fuses or reactivating of circuits or fuses.
3. Operating the equipment in accordance with the manufacturer's instructions and performing routine maintenance or any special maintenance listed in the user manual. Please refer to the **Maintenance** section of the user manual.
4. An annual preventive maintenance service is strongly recommended.
5. Providing the service dealer with free access to the equipment and its controls.
6. Removing any materials, fixtures or partitions that may interfere with the work of the service dealer.

■ AFTER-SALES SERVICE

If the unit you purchased has a quality problem or if you have any questions, please contact customer service by phone at **1 800 686-2175** or by email at **service@gree.ca**.

THE WARRANTY MUST MEET THE FOLLOWING REQUIREMENTS :

1. Only the manufacturer's accessories may be used on the appliance.
2. All instructions in this manual must be followed.
3. The warranty will be automatically invalidated if any of the above points are not followed.

Enter the following information about your product; it will help you upon getting assistance or service, if you ever need it. You will have to provide the model and serial numbers of the product. These informations are detailed on the rating plate of the unit.

Dealer name : _____

Address : _____

Model number : _____

Serial number : _____

Date of purchase : _____