

OWNER'S MANUAL

Dehumidifier

Model: GDN30AQ-A3EBA1A
GDN45AQ-A3EBA1B

Thank you for choosing our product. For proper operation, please read this manual carefully and keep it for future reference.

OPERATION NOTICES

- Unit Placement.....1
- Safety Precautions.....2
- Parts.....3
- Check Before Operation.....4

OPERATION INSTRUCTIONS

- Operation Method.....5
- Drainage Option.....8

MAINTENANCE

- Cleaning and Maintenance.....10

MALFUNCTION

- Troubleshooting.....12
- Malfunction Codes.....14
- Warranty.....15

Note: The images in this manual are only for reference. Please refer to actual products for specific details.

- This dehumidifier is intended for indoor residential applications only. It should not be used for commercial or industrial applications.
- Place the dehumidifier on a smooth and level floor.
- A dehumidifier operating indoors will have no effect in drying an adjacent enclosed area, such as a closet.
- Place the dehumidifier in an area where the temperature will not go below 5°C or above 32°C.
- Allow at least 30-45 cm of air space on all sides of the unit.
- Close all doors, windows and other openings in the room to improve the effect of the humidifier.
- Please keep the air inlet/outlet clean and unobstructed.
- Do not use a dehumidifier in a bathroom.
- Avoid direct sunlight.

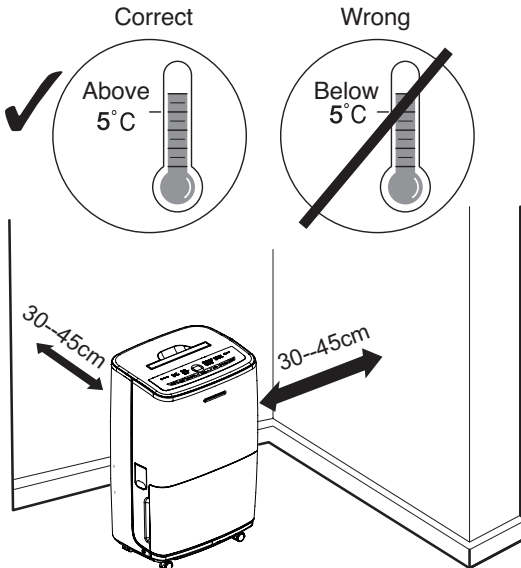

The dehumidifier has rollers to aid placement. Do not attempt to roll the dehumidifier on carpet or over objects. Water may spill out from the bucket or the dehumidifier may get stuck.

- Before operating, please check the power cord to make sure it complies with the requirement indicated on the nameplate.
- Before cleaning, please turn the unit off and unplug it.
- Make sure the power cord is not being compressed by any hard object.
- Do not remove the power plug or move the unit by pulling the power cord.
- Do not use any heating application near the dehumidifier.
- Do not remove the power plug with wet hands.
- Please use a grounded power cord and make sure it's well connected and not damaged.
- Children and disabled people should not use the dehumidifier without supervision.
- Keep children from playing or climbing on the dehumidifier.
- Do not place the dehumidifier under dripping objects.
- The memory function is included in this dehumidifier. When the unit is not in use, please turn it off and remove the power plug or disconnect the power.
- Do not repair or disassemble the unit yourself.
- A damaged power cord must be replaced by a qualified technician or manufacturer.
- If an abnormal condition occurs (e.g. burned smell), please disconnect the power at once and then contact local dealer.
- This dehumidifier can not be disposed of just anywhere. If you want to discard this dehumidifier, please check with local disposal information service center.
- Instructions for cord-connected room air conditioners include manufacture's recommendations regarding the use of cord sets (extension cords). If use of an extension cord is not recommended, the instructions state this. Recommendations for an extension cord shall specify at least the use of a cord set with grounding-type attachment plug and grounding-type connector (load fitting) ; as well as the amperage and voltage rating of the cord set.

Front side

ON LIGHT

CONTROL PANEL

FRONT GRILLE

WATER BUCKET

ROLLER

Back Side

AIR FILTER

POWER PLUG

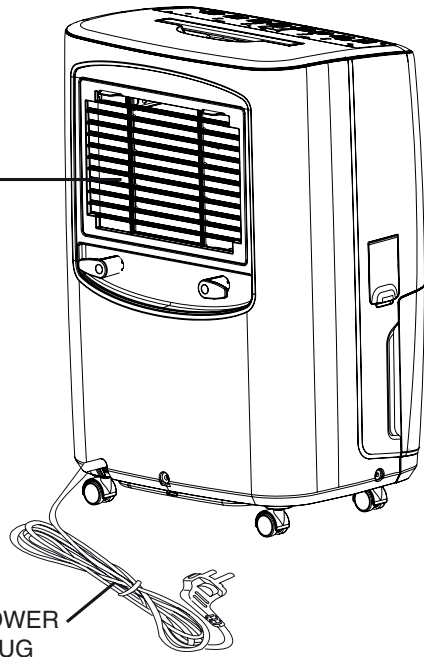
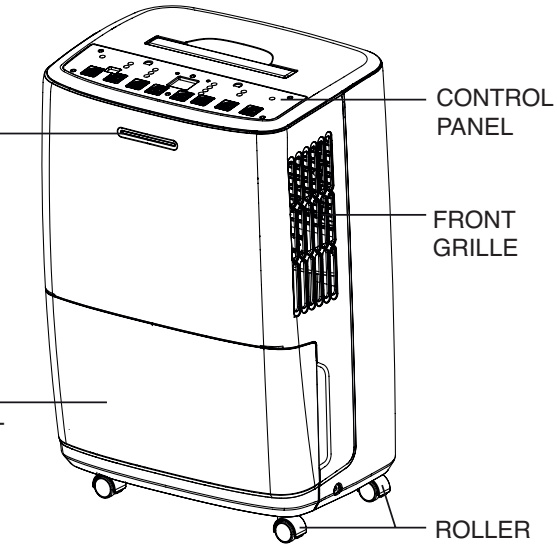

Before operating, please first check that the float is properly placed. Below are the steps to do this:

1. Hold the handles on both sides of the water bucket and pull out in the direction indicated by the arrows.

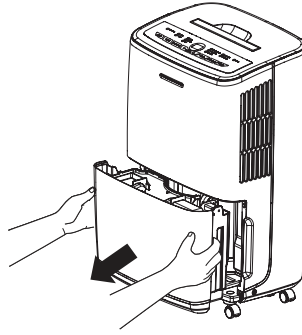

2. Check that the float in the water bucket is properly placed. It may have shifted during transportation. If it's not placed properly, move it to the correct position by hand.

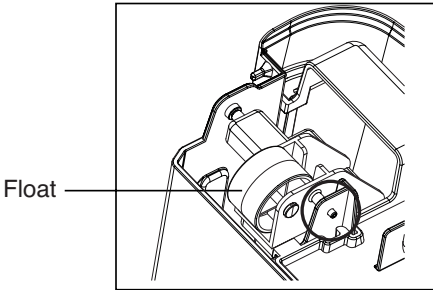

Correct Position

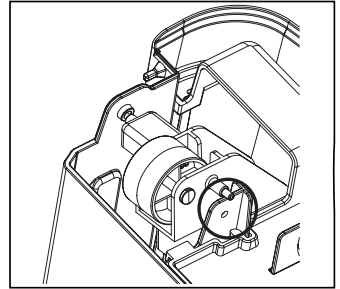

Wrong Position

3. Replace the bucket as instructed in step 1.

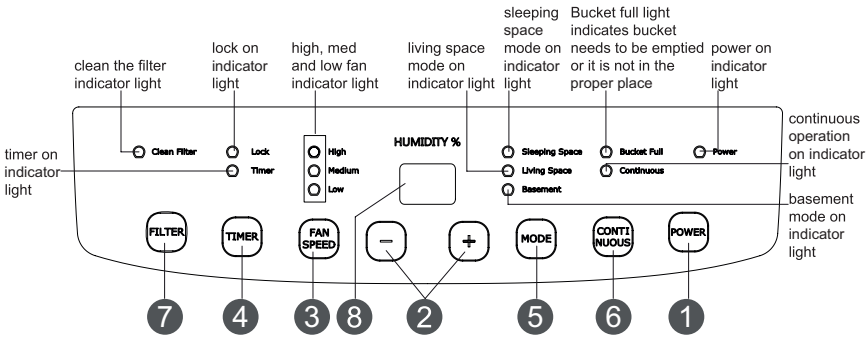
Notes:

- The water bucket must be correctly installed for the dehumidifier to operate.
- Do not remove the bucket while the unit is in operation.
- If you want to use a drain hose to drain water away, please install the hose according to the section "Drainage method".
- Whenever a button on the control panel is pressed, a "beep" will sound.
- When the power is connected, the power indicator on the control panel will turn on at the same time the dehumidifier emits a "beep".

Basic Functions of the Buttons

1 POWER Button

Press this button to turn the dehumidifier on or off.

2 + / - Button

In the free drying mode, press these buttons to set humidity. Invalid under other modes

- Pressing the « + » button will increase humidity while pressing the « - » button will decrease humidity. The display range of humidity is 35%~80%. Each press of a button will increase/decrease humidity by 5%.
- When setting Timer On or Timer Off, press these buttons to set the time. For specific details, please refer to the Timer Button description below.

When the unit is in operation, holding the « + » and the « - » button simultaneously for 3 seconds

will lock the buttons. If this function is turned on, the Button Locked Indicator will come on and the display window shows LC, which will blink 3 times. Then the ambient humidity is displayed again. To turn off this function, hold « + » and « - » simultaneously for 3s and the indicator will turn off.

3 FAN SPEED Button

Pressing this button sets fan speed.

Select from the cycle of: High, Medium, Low.

The corresponding indicator will turn on for each fan speed.

4 TIMER Button

Press this button to set Timer On or Timer Off (Timing range 0.5~24h).

● Set Timer Off:

When the unit is on, press this button and the Timer Indicator will turn on while the display window will show the time. Each press of the + or - button will increase or decrease the time by 0.5h or 1h (When the time varies within 10h, pressing + / - will increase / decrease the time by 0.5h; when the time varies from 10h to 24h, pressing + / - will increase / decrease the time by 1h). When the time is set, wait for 5s or press this button to turn this function on. The timing Indicator will turn on.

● Cancel Timer Off:

Under the condition that this function is turned on, press this button to cancel it. The timing Indicator will turn off.

● Set Timer On:

When the unit is off, press this button and the Timer Indicator will turn on while the display window will show the time. Each press of the + or - button will increase or decrease the time by 0.5h or 1h (When the time varies within 10h, pressing + / - will increase/decrease the time by 0.5h; when the time varies from 10h to 24h, pressing + / - will increase / decrease the time by 1h). When the time is set, wait for 5s or press this button to turn this function on. The timing Indicator will turn on.

● Cancel Timer On:

Under the condition that this function is turned on, press this button to cancel it. The timing Indicator will turn off.

● Timing range: 0.5~24 hours.

5 MODE Button

Press this button to select a running mode. Each time the button is pressed, the mode will switch among free drying, sleeping space, living space, basement and continuous drying modes, and the corresponding mode indicator will turn on. When in free drying, all mode indicators are OFF.

6 Continuous button

Press this button to set continuous dehumidify.

Note: The drain hose must be installed to use the CO mode. Otherwise, unit will stop when the water bucket is full.

7 FILTER Button

Press this button to turn off the Filter Cleaning Indicator. (When the dehumidifier has been operating for 250 hours, the Filter Cleaning Indicator will light up to remind to clean the filter.)

Other Instructions

1. Alarm Warning

If the bucket is full or not locked into place for over 3 min, a buzzer will go off for 10s to remind you to empty the bucket or put it back into the correct place.

2. Auto Stop

When the bucket is full, removed or not placed correctly or the humidity is 5% lower than the set humidity, the unit will automatically stop.

3. Memory Function

If power is lost, all of the control settings are remembered. So when power is restored, the unit will start back up in the settings it was in when the power was lost.

4. Bucket full light

This indicates that the bucket is full, removed or not placed correctly.

5. Clean the Filter indicator light

When the dehumidifier has been operating for 250 hours, the Filter Cleaning Indicator will light up to remind user to clean the filter.

6. On light

This indicates that the dehumidifier is on/off. When the dehumidifier is on, the On light can be turned off or on by pressing "Filter" and "+" together for 3 seconds. The light blinks continuously to show the bucket is full, removed or not placed correctly.

Option 1 Emptying Manually

Notes

- Do not remove the bucket when the unit is in operation or has just stopped. This may cause the water to drip on the floor.
 - Do not use the hose if using the water bucket to collect water. When the hose is connected, the water will drain out through it instead of into the bucket.
1. Hold the handles on both sides of the water bucket and pull it out in the direction indicated by the arrows. (Attention: Pull out the bucket carefully to prevent the water from spilling out of the bucket and onto the floor.)

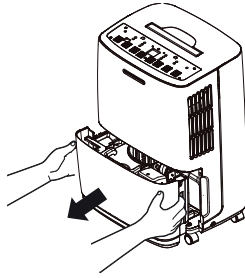

2. Empty the bucket by grasping the handle on the top of bucket with one hand and the bottom of bucket with the other hand.

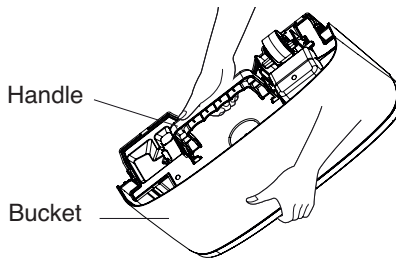

3. Replace the bucket in the dehumidifier in the direction indicated by the arrow.

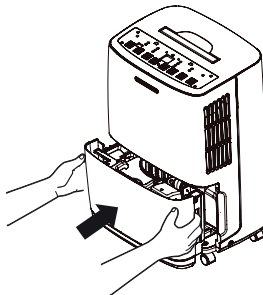

Other Instructions

1. The hose is not provided, so the user must procure it. [Size: The hose thread should have an outer diameter of 11/16 inches (1.0625 inches or 27.0mm), and a pitch of 11.5 TPI.]
2. Remove the bucket from the unit as instructed.
3. Thread the drain hose onto the nozzle and make sure it's securely locked.

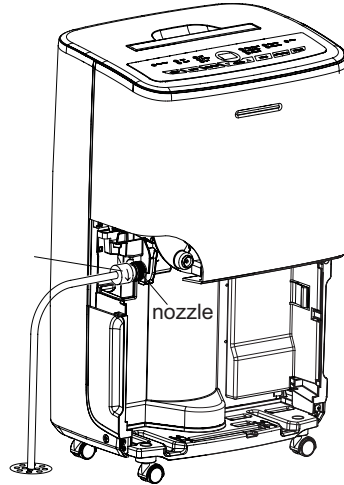

4. Replace the bucket. Make sure the drain hose goes through the bucket's drain hole and is placed downward. Feed the hose into the floor drain and then cover the hole with a lid. Note that the drain hose should not be compressed, the water cannot drain.

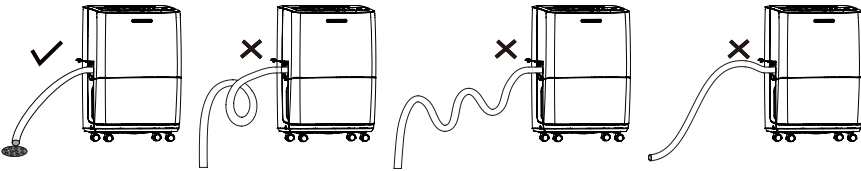

Note: When you want to take off the drain hose, prepare a receptacle to collect the water from the nozzle.

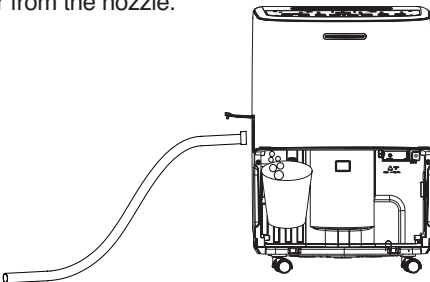

Warning:

- Before cleaning, turn off the dehumidifier and disconnect the power to avoid electric shock.
- Do not wash the dehumidifier with water to avoid electric shock.
- Do not use volatile liquid (such as thinner or gasoline) to clean dehumidifier. Otherwise it will damage unit's appearance.

1. Grille and Case

To clean the housing:

When there is dust on the housing, use a soft towel to dust it off. If the housing is very dirty (greasy), use mild detergent to clean it.

To clean the grill: Use a duster or brush.

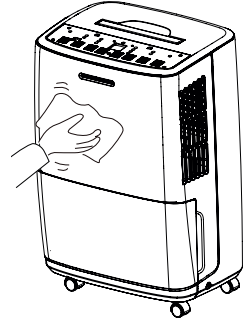
**2. Water Bucket**

Every few weeks, clean the bucket to prevent the growth of mold, mildew and bacteria. Use a soft brush to clean the bucket and then rinse it.

To remove:

(1) The rotor shaft on the handle toward the hole of buckle plate. Pull the bucket plate on the handle side in the direction indicated by the arrow. Remove the handle. (shown in Fig.1)

(2) Press the 3 buckles down around the water bucket. Lift up the drain lid. (shown in Fig.2)

Buckle Plate

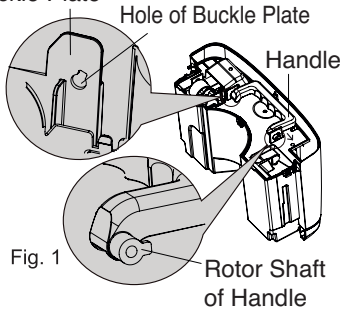

Fig. 1

Drain Lid

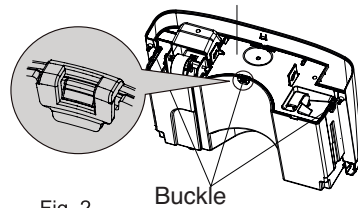
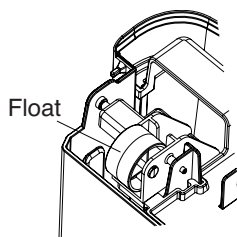

Fig. 2

(3) After cleaning, replace the drain lid and handle and make sure the float in the water bucket is placed properly. The side with foam should be beneath the drain lid. Do not remove the foam from the float.



3. Air Filter

The dehumidifier will remind you to clean the air filter when it has been operating for 250 hours. If it is used in dusty places, clean the air filter more often.

To remove: Pull the buckles and pull out the filter.

To clean: Wash the filter in warm, soapy water.

Rinse it and let the filter dry before replacing it.

Float

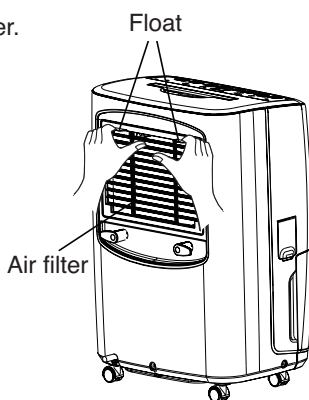

Warning:

- Do not operate the dehumidifier without a filter. Otherwise the evaporator will catch dust and affect the unit's performance.
- Do not dry the air filter with heat or an electric hair dryer. Otherwise the air filter may be misshapen or catch on fire.

Check Before Use-seasonally

- Check whether air outlet is blocked.
- Check whether power plug and power socket are in good condition.
- Check whether air filter is clean.
- Check whether drain hose is damaged.

Care After Use-seasonally

- Disconnect power.
- Clean the air filter and housing.
- Clean dust and obstacles from the dehumidifier.
- Empty the water bucket.

Long-term Storage

If you won't be using the dehumidifier for a long time, we suggest that you follow the steps below in order to term the unit in good condition.

- Make sure the bucket is empty and the drain hose is removed.
- Unplug the dehumidifier and pack the power cord.
- Clean the unit and wrap it well to prevent the dust from accumulating.

● **Not all the following problems are malfunctions.**

PROBLEM	POSSIBLES CAUSES
Dehumidifier is not operating. Controls cannot be set.	<ul style="list-style-type: none"> ● Unit is operating in an area where the temperature is higher than 32°C or lower than 5°C. ● Bucket is full.
Noise suddenly starts when operating	<ul style="list-style-type: none"> ● Noise will be heard if the compressor has just started. ● Power supply problem. ● Unit is placed on uneven floor.
Humidity does not drop.	<ul style="list-style-type: none"> ● Area to be dehumidified is too large. The capacity of your dehumidifier may not be adequate. ● Doors are open. ● There might be a device producing vapor in the room.
Little or no effect in dehumidifying	<ul style="list-style-type: none"> ● Room temperature is too low. ● Humidity level may be improperly set. ● If unit is operating in a room where temperature is from 5 to 15 °C, it will start to defrost automatically. Compressor will stop for a brief period of time (fan will operate a high fan speed). When unit finishes defrosting, it will go back to normal operation.
When first turned on, the air emitted has musty-odor.	<ul style="list-style-type: none"> ● Due to increased temperature of heat exchanger, the air may smell strangely at the beginning.
Unit has noises.	<ul style="list-style-type: none"> ● There might be some noise if unit is operating on a wooden floor.
Swooshing sound is heard.	<ul style="list-style-type: none"> ● Normal. This is the sound of the flow of refrigerant.

● **Problem of Water Leakage.**

PROBLEM	Possible causes	Solutions
When using the drain hose, there is water in the bucket.	<ul style="list-style-type: none"> ● Examine the drainage joint. 	<ul style="list-style-type: none"> ● Connect the drainage joint well.
	<ul style="list-style-type: none"> ● Drain hose is not correctly installed. 	<ul style="list-style-type: none"> ● Unblock the drain hose.
	<ul style="list-style-type: none"> ● Drain hose is not correctly installed. 	<ul style="list-style-type: none"> ● Remove the drain hose and replace it. Be sure that the hose is correctly installed.

• Dehumidifier does not start.

PROBLEM	Possible causes	Solutions
When using the drain hose, there is water in the bucket.	<ul style="list-style-type: none"> • Power is not supplied to the dehumidifier or the power plug is not well inserted. 	<ul style="list-style-type: none"> • Check if power is lost. If yes, wait for the power to restore. • If not, check whether the power circuit or power socket has been damaged. • Check whether the power plug is loosen. • Check whether the power cord is damaged.
	<ul style="list-style-type: none"> • Fuse is blown. 	<ul style="list-style-type: none"> • Replace the fuse.
Bucket full indicator is lit up.	<ul style="list-style-type: none"> • Bucket is not properly placed. • Bucket is full of water. • Bucket has been removed. 	<ul style="list-style-type: none"> • Empty the bucket and replace it.
Unit functions normally but does not start up.	<ul style="list-style-type: none"> • Humidity is set too high. 	<ul style="list-style-type: none"> • If you want the air drier, press «—» to lower the number or press the CO button for the unit to dehumidify continuously.

• Dehumidifier does not dry air as intended.

Bad dehumidifying performance	<ul style="list-style-type: none"> • Check whether there is any obstacle around the unit. 	<ul style="list-style-type: none"> • Make sure there is no curtain, shutter or furniture blocking the dehumidifier.
	<ul style="list-style-type: none"> • Air filter is dusty and blocked. 	<ul style="list-style-type: none"> • Clean the filter.
	<ul style="list-style-type: none"> • Doors and windows are left open. 	<ul style="list-style-type: none"> • Make sure all doors and windows and other openings to the outside have been closed.
	<ul style="list-style-type: none"> • Room temperature is too low. 	<ul style="list-style-type: none"> • Warm temperatures are good for dehumidification. Low temperatures will reduce unit's effect. This unit should be used in a place where temperature is above 5°C.

● Unit's Malfunction Codes

No.	Malfunction Name	Display Code	Unit's Condition	Possible Causes
		Display Window		
1	Ambient Temperature Sensor Malfunction	F1		● Ambient temperature sensor is loose or is poorly connected to the terminal of display board.
				● An element of display board may have been put in upside down and caused short circuit.
				● Ambient temperature sensor is damaged (Please refer to Checking Table for Temperature Sensor Resistance).
				● Display board is damaged.
2	Tube Temperature Sensor Malfunction	F2	Buttons for the compressor, fan, pump do not work.	● Temperature sensor on the evaporator is loose or is poorly connected to the terminal of display board.
				● An element of display board may have been put in upside down and caused short circuit.
				● Temperature sensor on the evaporator is damaged (Please refer to Checking Table for Temperature Sensor Resistance).
				● Display board is damaged.
3	Humidity Sensor Malfunction	L1		● Humidity sensor has short-circuited.
				● Humidity sensor is damaged.
				● Display board is damaged.

LIMITED WARRANTY

This dehumidifier is covered by a warranty against defects in materials and workmanship, if used for the applications specified in this owner's manual, for a period of ONE (1) year from the date of original purchase in Canada.

During the warranty period, if the dehumidifier fails under normal use, **GREE** will, at its option, either repair the unit or replace it, free of charge, within a reasonable period of time after the dehumidifier is returned.

As a condition to any warranty service obligation, the customer must present this warranty certificate along with the proof of purchase.

THIS WARRANTY DOES NOT COVER:

1. Damage, accidental or otherwise, to the dehumidifier that is not caused by materials or workmanship defect.
2. Damage caused by misuse, tampering or failure to follow the operating and maintenance instructions provided in this owner's manual.
3. Damage to the finish of the unit housing or to other outer features caused by wear.
4. The filter.
5. Damage caused by repairs or modifications to the humidifier made by any person not duly authorized by **GREE**.
6. **Insurance and freight costs for the warranty service.**

ALL IMPLIED WARRANTIES, INCLUDING ANY IMPLIED WARRANTY OF MERCHANTABILITY, ARE LIMITED TO A ONE YEAR (1) PERIOD COVERED BY THIS EXPRESS LIMITED WARRANTY. **GREE** DISCLAIMS ANY LIABILITY FOR CONSEQUENTIAL OR INCIDENTAL DAMAGES AND, IN NO EVENT, SHALL **GREE** LIABILITY EXCEED THE RETAIL VALUE OF THE HUMIDIFIER FOR BREACH OF ANY WRITTEN OR IMPLIED WARRANTY WITH RESPECT TO THIS PORTABLE DEHUMIDIFIER.

Keep this owner's manual along with your proof of purchase in a safe place for future reference. You must provide proof of purchase for warranty service.

Enter the following information on your portable dehumidifier; it will help you when getting assistance or service if you ever need it. You will have then to provide the model and serial numbers of the dehumidifier, which can be found on the rating plate of the unit.

Dealer name: _____

Address: _____

Model number: _____

Serial number: _____

Date of purchase: _____

