

PT BATTERY 14

User Manual

Manufactured by:
**HYBRID
POWER
SOLUTIONS**

288 Judson St #5
ON M8Z 5T6

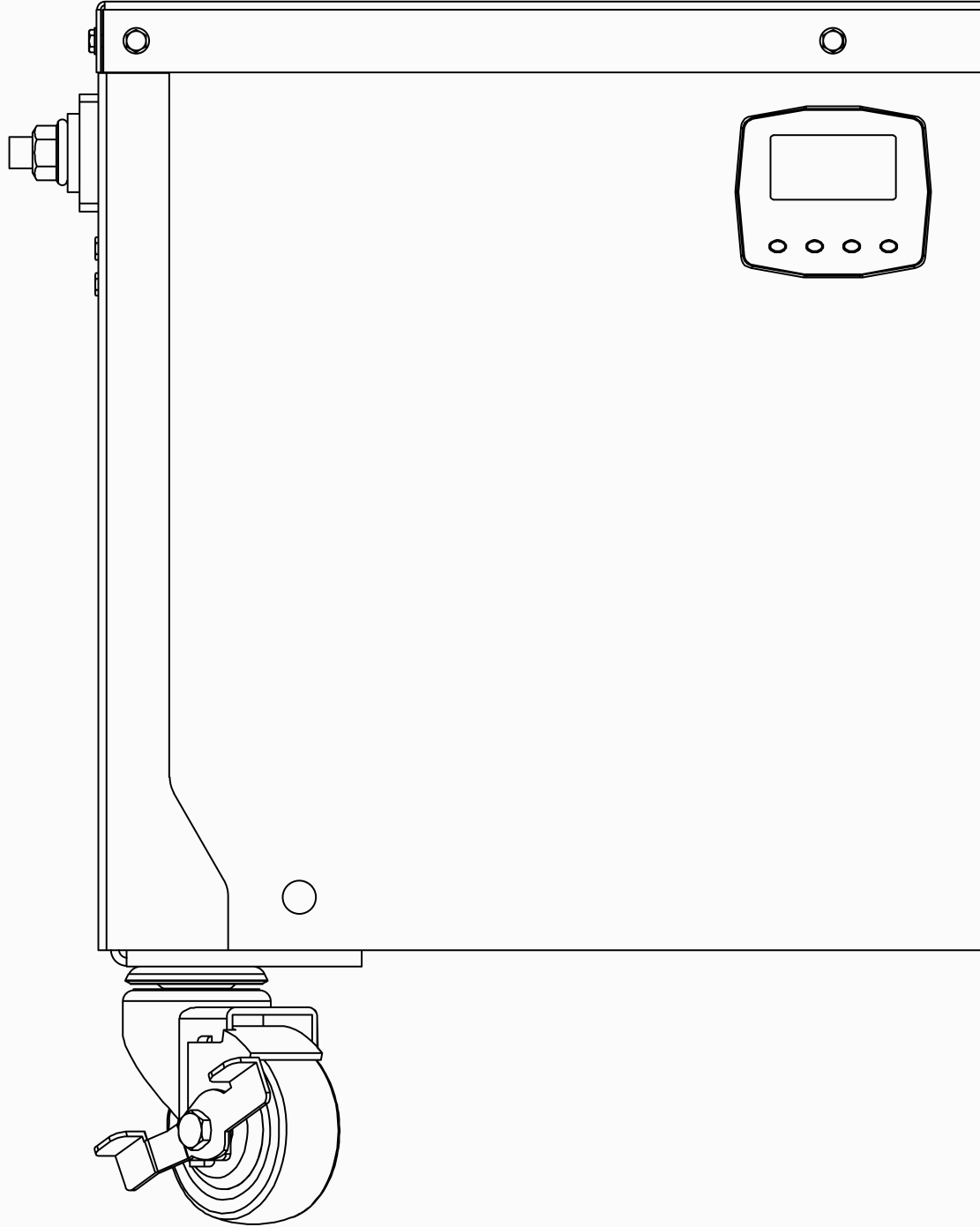

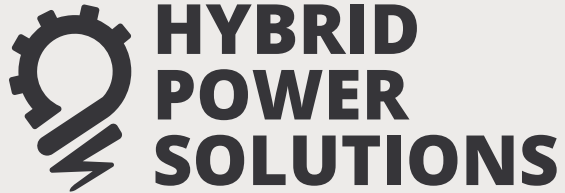

[This page intentionally left blank]

PT Battery 14

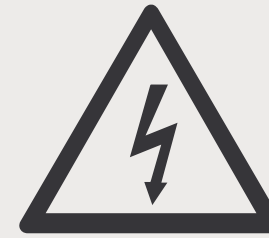

SHOCK HAZARD:

Possible shock or death if used improperly, when damaged or used by untrained personnel.



ATTENTION:

It is the customer's and installer's obligation to check local electrical requirements and certification requirements of all HPS purchased equipment.



FLAMMABLE HAZARD:

Lithium ion batteries contain flammable liquid electrolyte that may vent, ignite and produce sparks when subjected to high temperatures (> 150 °C (302 °F)), when damaged or abused (e.g., mechanical damage or electrical overcharge). Burning cells can ignite other batteries in close proximity.

Vapors or mists from a ruptured battery may cause respiratory irritation.

Manual **INDEX**

Content	Page
Overview	08
Safety Information	10
Configuration	12
Commissioning / Seasonal Storage Process	16
Operation	19
Transportation, Maintenance, and Temperatures Guide	22
Warranty	24
Battery Integration	27
Rapid Shutdown Circuit/ E-Stop Circuit	36

1.1. Product Description

Thank you for choosing the Power Tower Battery from Hybrid Power Solutions (HPS). We hope you enjoy and use this battery to its full potential.

Please unpack your battery carefully and check the delivery for completeness and obvious damage. In case of damage inform us immediately.

The battery is delivered to you in a ready-to-use state with 30% energy (+/-10%). However, please make sure you read through this user manual carefully. If you have further questions regarding the Power Tower Battery, please contact HPS.

The PT Battery 14 is made in Canada with domestic and imported parts.

1.2. Contact Details

Hybrid Power Solutions Inc.

Customer Service/ Technical Support
288 Judson St Unit #5, Toronto, ON M8Z 5T6
Canada

Phone: +1 (647) 347-6000

E-Mail: Info@hybridps.ca

Website: hybridps.ca

SAFETY INFORMATION

SECTION 2

2.1. General Safety Instructions

Before operating the Power Tower Battery, carefully read and fully understand the instructions, cautions and safety notices shown on the second page of this manual. Following all instructions for proper operation and troubleshooting will reduce the risk of personal injury, death and/or property damage.

These instructions are not intended as a complete list of all details for operating and troubleshooting, although reading and following them will aim to keep you safe. If you have any questions or concerns about procedures or safety that are not covered by these instructions, do not hesitate to contact HPS.

2.2. Operator Responsibility

Treat the system with general care, by turning the system off when not in use.

If an unfamiliar sound or smell is noted to come from the unit, please turn off the unit and notify HPS immediately. Leave in a well-ventilated area, away from flammable sources.

WARNING:

- It is the customers and installers obligation to check local electrical requirements and certification requirements of all HPS purchased equipment.
- Do not put fingers and/or any other object into the units plugs.
- Always use compatible inverters or loads.
- Never open the unit case.
- Do not expose the cell to temperatures outside the range of -30°C to 60°C.
- To minimize any adverse effects on battery performance it is recommended that the system be kept at room temperature (20°C +/- 5°C). High or low temperatures can result in shortened cell life.
- Keep out of reach of children.

2.3. Condition of Use

If the system is in abnormal physical condition, please do not use it.

Critical Errors: If an error message is present, please contact HPS support for reset or repair.

If internal components are heard/ believed to be loose inside/ rattling, please call HPS for technical support.

3.1. Overview

The Power Tower Battery system is designed to work with the Power Tower Off-Grid system but may also be used with a variety of other inverters and loads if the appropriate usage parameters are respected. Please see the Integration section for use with other inverters or applications.

3.2. Technical Specifications

Voltage	51.2V
Max. Amp output	280A
Min. / Max. Voltage	42.4V / 56V
Approximate weight	93kg [205 lbs]
Usable energy	14kWh (@ 100% DOD) 280Ah
Recommended charge amperage	<140A (280A max)
Charge operating temperature	0 to 45 °C
Operating temperature	-20 to 60 °C
Storage temperature	-30 to 60 °C
Atmospheric pressure	86 to 106 kPa
Relative humidity	25 to 85% RH
Internal fuse	300A
Parallel Connection	20 Maximum
Series connection	NEVER CONNECT IN SERIES
Cycles	2250 cycles (charging CC/CV @0.3C & discharging CC @0.3C, 100% DOD, 25°C +/-2°C 100% of rated capacity), 3800 cycles (charging CC/CV @0.3C & discharging CC @0.3C, 70% DOD, 25°C +/-2°C 100% of rated capacity), 10,000 cycles (charging CC/CV @0.3C & discharging CC @0.3C, 70 DOD, 25°C +/-2°C 70% of rated capacity)
Dimensions	61cm x 38.1cm x 48.2cm [24in x 15in x 19in]
Certifications	UN38.3, ESA inspected to CSA Standards (SPE-1000)

3.2. PT Battery 14 General Dimensions



Third angle view

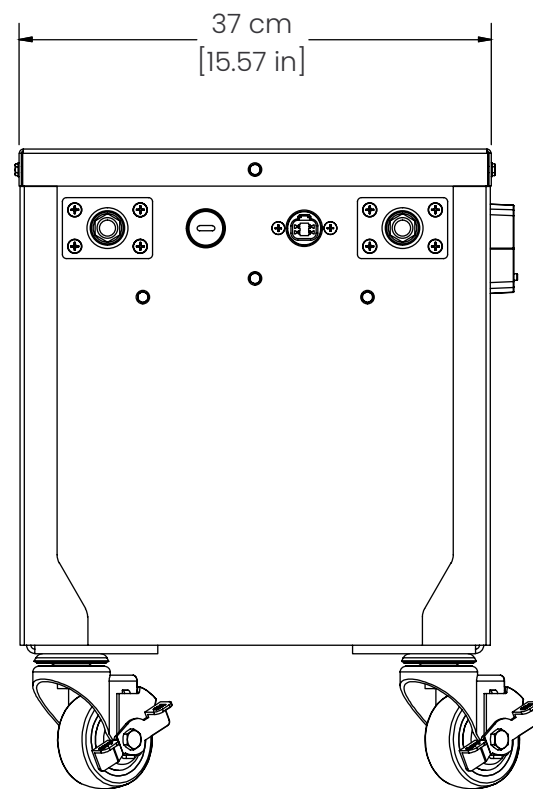

Side view

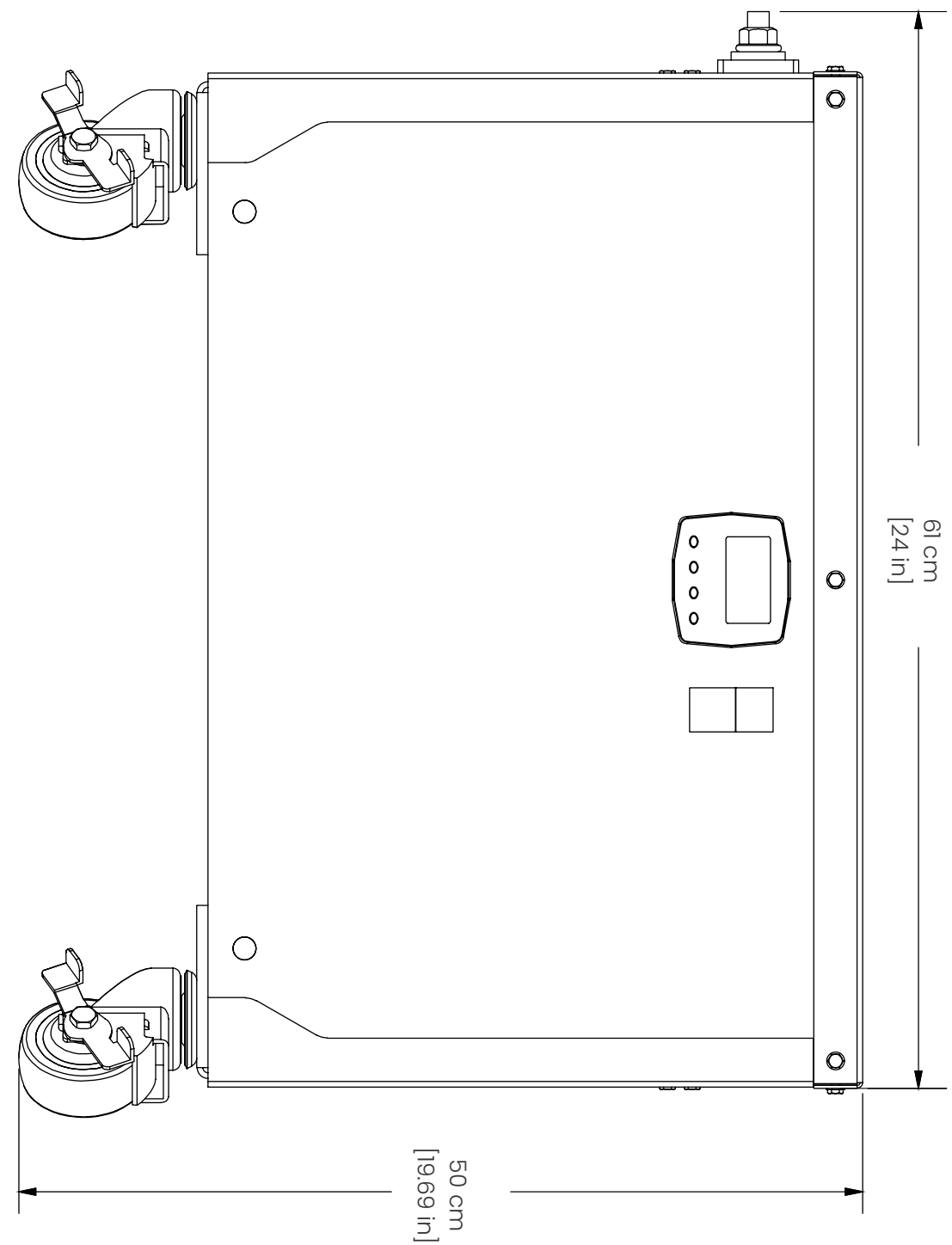

COMMISSIONING / SEASONAL STORAGE PROCESS

SECTION 4

The initial integration of the battery system with your inverter, charger or load is crucial to proper operation. DO NOT mix the Power Tower Battery with any other type of battery including other lithium, LiFePO4, SLA, GEL or flooded batteries.

NEVER plug the Power Tower Batteries in series.

4.1. Initial Commissioning

4.1.1. Single Battery Commissioning

If only a single Power Tower Battery is used, then no balancing or voltage check is required.

- 1 - Turn ON the battery master switch to ensure no errors are present
- 2 - Turn OFF master switch (After turning off the inverter, the breaker should be turned off first.)
- 3 - Connect Positive wire first
- 4 - Connect Negative wire
- 5 - Turn Master Switch ON
- 6 - Turn ON load

If the battery does not output any voltage after turning on the load (inverter or other), this may be a result of a rapid capacitor charging inside the load that may be tripping the battery's internal safety mechanism. This can be overcome by connecting a second battery in parallel to share the spike or use a pre-charge resistor.

Certain inverters and capacitive loads may have an inrush of over 1000A on startup which may trip the internal safety cut off of the battery. To charge these capacitors and still maintain the safety profile of the battery, a pre-charge resistor can be used during commissioning. Please review the information in the following resource to match the capacitance of your load (contact inverter manufacturer): <http://liionbms.com/php/precharge.php>. A

100-250W resistor with a 20-50 ohm rating is recommended. Contact HPS or your local solar installer or electrician for assistance.

4.1.2. Multiple Battery Commissioning

1. Connect all the Batteries together via the Provided communication Wire Provided, As shown in the Customer Wiring Diagram.
2. Connect all the Positive wires to the Power Tower.
3. Connect all the Negative wires to the Power Tower.
4. Turn On each battery one by one and wait about 10 seconds after they are all on for the batteries to communicate.
5. Turn on Load.

4.1.3. Smart Balancing Feature

The PT14 Battery has a smart integration system when all batteries are connected using the communication wires. This feature only integrates new battery packs when the voltage is equal to the rest of the system. This ensures no pre-balancing is required and no damage will occur to the system if unbalanced batteries were to be connected together. If during the first two cycles you notice that the display is not showing the proper number of batteries, you may have a battery that is out of balance. Rest assured that as the voltage changes when charging or discharging the system, the battery will reconnect automatically. To accelerate this process, make sure to fully discharge and charge the connected batteries.

In extreme situations the battery that is out of balance may be severely depleted or full and it may be challenging to integrate. In this situation, charge this battery or discharge this battery to around 50% to ease integration. This can be accomplished by disconnecting the batteries that are currently on the inverter/charger and connecting the battery that is having issues to charge or discharge, then reconnecting the rest of the batteries.

4.2. Grounding

Ensure that the battery's metal enclosure is ground to earth in a grounded system or the battery negative terminal when operating a floating system.

4.3. Seasonal or Long Term Storage

If seasonal shut down is required, please follow the below steps:

1. Fully charge battery
2. Turn OFF load and charger
3. Turn OFF batteries
(After turning off the inverter, the breaker should be turned off first)
4. Store batteries in location that does not fall outside specifications including in areas where temperatures could fall below -30 °C

Periodically check battery voltage by turning batteries ON with no load connected. Ensure voltage is above 50V. If below, batteries should be recharged.

5.1. Component Identification and General Operation

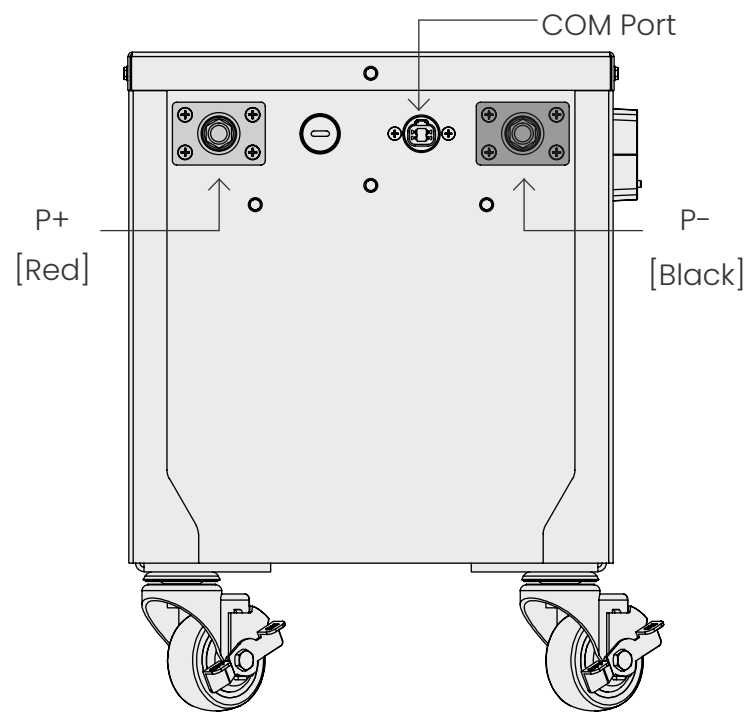
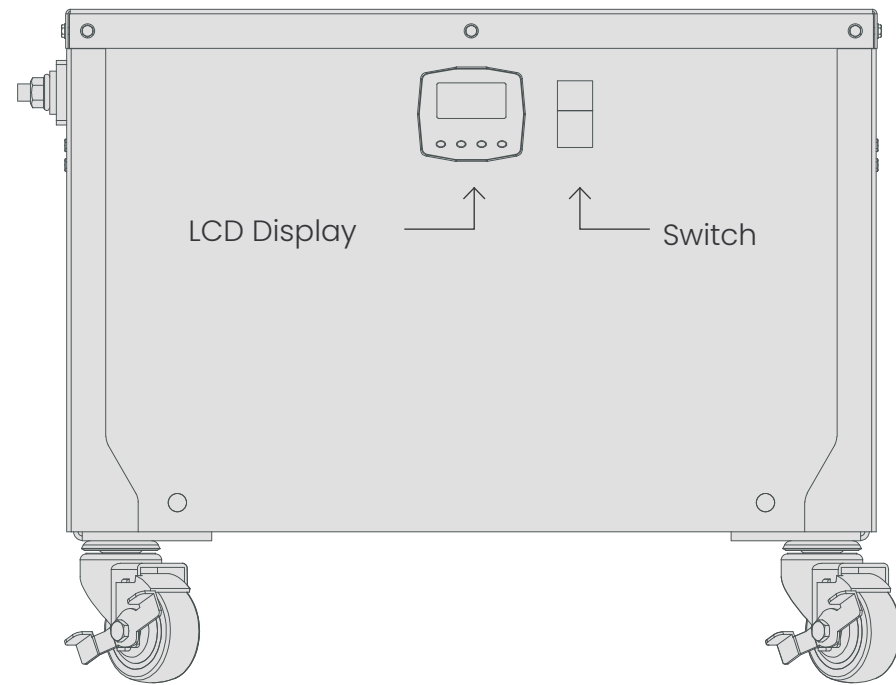

P+ : Positive terminal

P- : Negative terminal

Switch : Master ON/OFF switch. Should only be operated with limited or no load or in emergency situations.

LCD Display



SOC: State of Charge (battery percentage)

The system should always be left in the OFF position when not in use. In the ON position, very little power is consumed but it will affect future run times and may deplete the system over time. HPS recommends always turning the battery off when not in use.

When using the system in cold temperatures (below 0 degrees Celsius), discharge power may be limited and run time can be affected by up to 40%. The product will naturally warm itself with usage and improve capabilities. For maximum capacity and performance, ensure the battery is stored at room temperature (20 degrees Celsius).

5.2. Recharging Guide and Storage

Charge a minimum of once every 3 month to ensure the energy level does not fall to damaging levels. If this is not possible, periodically check that the voltage is above 50V.

Never charge above 280A. To achieve advertised life cycle, each battery pack should only be charged at <140A

Ensure to follow integration programming guidelines if using this battery with anything other than a Power Tower.

TRANSPORTATION, MAINTENANCE, AND TEMPERATURES GUIDE

SECTION 6

6.1. Transportation & Shipping

If shipping is required, please ensure to list the Power Tower Battery with carrier as a hazardous goods and follow all required precautions and regulations. The Power Tower Battery is a UN38.3 certified, class UN3480 (lithium ion battery). It is the shipper's responsibility to ensure all paperwork and required packaging is in order. Contact HPS or your shipper for support on this matter.

6.2. Maintenance & Cleaning

Warning: Do not spray with water or leave outdoors.

- Always make sure to turn the unit **OFF** when not in use and to keep the unit in charged state if possible.
- No user maintenance is required.
- To clean the battery, simply turn the system off, disconnect all leads and clean with wet cloth avoiding the battery terminals.

6.3. Extreme Temperatures

Warning: using the product in extreme temperatures, above 45°C and below -30°C may reduce the total life cycle of the product and cause permanent damage.

Always charge the Power Tower Battery in temperatures above 0 °C. Charging below this will result in the system shutting down and protecting itself.

Note that performance may be affected in temperatures under 0 °C. Run time can be reduced as well as available power.

WARRANTY

SECTION 7

8.1. Manufacturer's Warranty Coverage

All Power Tower Batteries supplied by Hybrid Power Solutions are tested for reliability and performance before delivery for correct function and condition.

We grant no warranty or liability for defects and losses that occur during the use by the customer or the shipment of the unit.

Please refer to this user manual to ensure proper user operation and operating conditions, which will ultimately prolong the life of the Power Tower Battery unit. The warranty does not cover negligence to this manual's directions.

Hybrid Power Solutions (HPS) warrants its products against defects in material and workmanship. Under normal use and service, every hardware portion of the product will be free from physical defects in material and workmanship during the warranty period, or the product will be repaired or replaced as determined solely by HPS. HPS provides a limited warranty for its products only to the person or entity that originally purchased the product from HPS or its authorized distributor or retailer.

WARRANTY PERIOD: 5 YEARS. HPS warrants that its product be free against defects as stated above for a period of 5 years. This warranty does not scale back or lower its value over the period of time. **If it's our fault, we will repair or replace it. Simple as that.**

8.2. Owner's Warranty Responsibility

If the product does not operate as warranted above during the applicable warranty period, HPS shall, at its option and expense (except for shipping cost), repair the defective product or part, deliver to the customer an equivalent product or part to replace the defective item. All products that are replaced will become the property of HPS. Replacement products may be new or reconditioned as determined by state of the original unit.

For this warranty to remain valid, all wiring instruction must be strictly adhered to and installation must be made according to all directions and guidelines made in this manual or provided with the battery. All inverter and charger settings must be modified to accommodate this battery or else the warranty is void.

This limited warranty gives you specific legal rights. You may have further legal rights and remedies under local laws in your country. The terms of this limited warranty will apply to the extent permitted by applicable law. Some countries do not allow disclaimers of implied warranties or limitations on how long an implied warranty lasts, meaning the disclaimers and limitations set forth in this limited warranty may not apply to you. Some countries require specific disclosures to be inserted in an implied warranty. Please see the specific disclosures set forth in the appendix to this warranty; specific disclosures may relate to your country. For a full description of your legal rights you should refer to the laws applicable in your country.

BATTERY INTEGRATION

SECTION 8

This limited warranty and any dispute or claim arising out of or in connection with it (including non-contractual disputes or claims) is governed by and construed in accordance with the laws of the country or (if applicable) state or province where the warranted product is first installed. If any provision of this limited warranty is held by a court of competent jurisdiction to be unenforceable because it is invalid or in conflict with any law of any relevant jurisdiction, the validity of the remaining provisions shall not be affected, and the rights and obligations of the parties shall be construed and enforced as if the unenforceable provisions were replaced by valid, legal and enforceable provisions that come closest to the intent underlying the invalid or unenforceable provision. The United Nations Conventions on Contracts for the International Sale of Goods (1980) shall not apply to this limited warranty or any aspect of any dispute relating to this limited warranty.

8.3. Exclusions

Warranty does not apply, if:

- The warranty period is expired.
- The warranty label is broken or removed.
- The serial number label is missing or unrecognizable.
- The product has been modified, opened or repaired by any unauthorized service center or personnel.
- The defect was subject to abuse, improper use not conforming to product manual instructions, or environment conditions more severe than those specified in the manual operating condition and user operation.
- Used with an improper charger, inverter, or load.

9.1. General Settings For Non-specific Chargers And Inverters

Almost any battery charger and inverter can be used if the proper settings are programmed but a LiFePO4 charger is recommended for optimum life and performance.

9.1.1. Lead Acid Chargers

If using a lead acid charger, ensure that the charger specifications do not surpass the parameters listed in the following section. Some **flooded lead acid chargers MAY NOT be used** as they surpass these parameters. Any charger with an **equalize mode or desulfating** setting must have both features turned off or else **NOT BE USED**.

9.1.2. Charging Parameters:

Parameter	48Vdc Version
Battery Chemistry	LiFePO4
Equalizer Support	Enabled
Battery Capacity*	280Ah
Charge Cycle (if avail.)	2 stage no float
Bulk Voltage	54.5V
Absorb Voltage	54.5V
Float Voltage	53.3V
Max Float Current*	10A
Battery Temperature Compensation	0

*This value should be multiplied by the number of Power Tower Batteries in parallel (up to the maximum provided by the inverter or charger)



9.1.3. Discharge Parameters:

Parameter	48Vdc Version
Max Discharge Amperage*	280A
Max Pulse Discharge*	400A
Max Pulse Time	3 seconds
Minimum Discharge Voltage	50Vdc (Maximum Cycles Settings) 46Vdc (Maximum Discharge Settings)

*This value should be multiplied by the number of Power Tower Batteries in parallel (up to the maximum provided by the inverter or charger)

9.1.4. Cold Weather Operation:

If constantly discharging in cold weather the overall battery voltage will be much lower and the inverter/load discharge setting may be changed to accommodate this. Reduce the voltage settings from section 9.1.3. by 3Vdc. Note that you will likely experience a 20-35% drop in capacity when approaching -30°C.

9.1.5. Schneider Conext XW Series Setup:

1. Go to Device and select device.
2. Select Advanced Settings.
3. Select Charger Settings.
4. Select Batt Type.
5. Select Lithium Ion (may be under custom).
6. If lithium Ion is available, change the following setting (if not skip to 7.) Any setting not shown below can be left to default:
 - a. Batt Capacity: 280Ah
 - b. Max Charge Rate: <140A
 - c. Charge Cycle: 2StgNoFloat
 - d. Recharge Volts: 50.5V
 - e. Absorb Time: 1h
 - f. DisChgImax Timer: 300 sec



7. Lithium Ion Setting:

- a. Bulk Voltage: 54.5V
- b. Absorb Voltage: 54.5V
- c. MaxAbsCurrent: 40A
- d. Float Voltage: 53.3V
- e. MaxFloatCurrent: 10A
- f. DisChagI_{max}: 150%
- g. DisChgI_{max}: 3 sec

9.1.6. Schneider Solar Charger Settings:



1. Go to Device and select device (MPPT).
2. Select Advanced Settings.
3. Select Charger Settings.
4. Custom:
 - a. EqLz Support: Disabled
 - b. Bulk Voltage: 54.5V
 - c. Absorb Voltage: 54.5V
 - d. Float Voltage (if available): 53.3V
 - e. Batt Temp Comp: 0mV/C
 - f. Batt Capacity: 280Ah
 - g. Max Charge Rate: <140A
 - h. Charge Cycle: 3 Stage
 - i. Recharge Voltage: 50.5V
 - j. Absorb Time: 2h
 - k. Default Batt Temp: Warm
 - l. Aux Settings: Not Used

9.1.7. BMS CAN BUS Capable Inverters:

When connecting an inverter that has CAN BUS and that is compatible with the batteries BMS (i.e. Solark, Victron, Schneider, etc). Connect the battery communications harness to the inverter CAN line. Depending on the system you

can use the ethernet adapter and simply plug in the harness to the inverters communications port or wire the harness directly if there are only screw terminals (please refer to connector pinout in section 10). After a connection is made from battery to inverter, the inverter will need to be set up to allow for BMS control (this can vary from system to system) please refer to the inverter manual for BMS setup. Once the Inverter is set up for BMS communication, the battery will send the inverter various messages (max and min current, voltages, etc.) and the inverter will then change its setting to accommodate the battery.

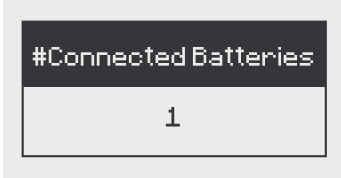
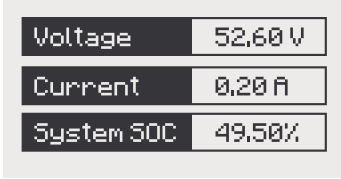
9.2. Operating Indicators

Connected batteries	
	<p>This Indicates the number of active connected batteries, an active battery is defined as having its outputs electrically connected (positive and negative terminals live). Although a battery may be physically connected to the inverter or another battery, there are scenarios where it may not be electrically connected for example if the battery has a fault or if multiple batteries are connected and one is not balanced, the battery that is out of balance would not be allowed to output until the other batteries enter a similar state of charge.</p>
General Overview	
	<p>Shows system voltage, total current draw, and system state of charge.</p>
Battery SOC	
	<p>Percentage of battery remaining. This value will be most accurate after discharging and charging the battery fully 5 times or more.</p>
Pack amp / hours	
	<p>Battery remaining amp hours (Ah).</p>

Pack Health	
<div style="border: 1px solid black; padding: 5px; width: fit-content; margin: 0 auto;"> <div style="background-color: #333; color: white; padding: 2px; text-align: center;">Pack Health</div> <div style="text-align: center; font-weight: bold;">100%</div> </div>	<p>The State of Health (referred to as SOH or Battery Health) is a term that is used to describe how healthy or strong a battery pack is. Over time a battery pack's capacity and performance can degrade due to cell aging or exposure to extreme temperatures. These degradations can cause reduced capacity or reduced efficiency.</p> <p>Typically this value is calculated based on observed capacity and nominal capacity (that is, a relationship between how much capacity is actually observed by the BMS and how much capacity the battery pack started off with when new) and the Internal Resistance of the pack.</p>
Cycles	
<div style="border: 1px solid black; padding: 5px; width: fit-content; margin: 0 auto;"> <div style="background-color: #333; color: white; padding: 2px; text-align: center;">Cycles</div> <div style="text-align: center; font-weight: bold;">0</div> </div>	<p>This is the total number of cycles that the battery pack has been put through since the BMS has started keeping track. A battery cycle is defined as a net transfer of the total Amphour capacity of the pack. In other words, on a 40Ahr battery one cycle would be a net transfer of 40 Amphours.</p>
Temperature	
<div style="border: 1px solid black; padding: 5px; width: fit-content; margin: 0 auto;"> <div style="background-color: #333; color: white; padding: 2px; text-align: center;">Temperature</div> <div style="text-align: center; font-weight: bold;">24 C</div> </div>	<p>Average battery temperature from all sensors.</p>
Total system current	
<div style="border: 1px solid black; padding: 5px; width: fit-content; margin: 0 auto;"> <div style="background-color: #333; color: white; padding: 2px; text-align: center;">Total System Current</div> <div style="text-align: center; font-weight: bold;">0.20 A</div> </div>	<p>Current output or input (negative value) from the entire battery system which includes all connected batteries.</p>
System power	
<div style="border: 1px solid black; padding: 5px; width: fit-content; margin: 0 auto;"> <div style="background-color: #333; color: white; padding: 2px; text-align: center;">System Power</div> <div style="text-align: center; font-weight: bold;">0.011 KW</div> </div>	<p>Power being output or input into the battery system.</p>

9.3. Multiple Battery Wiring Diagram

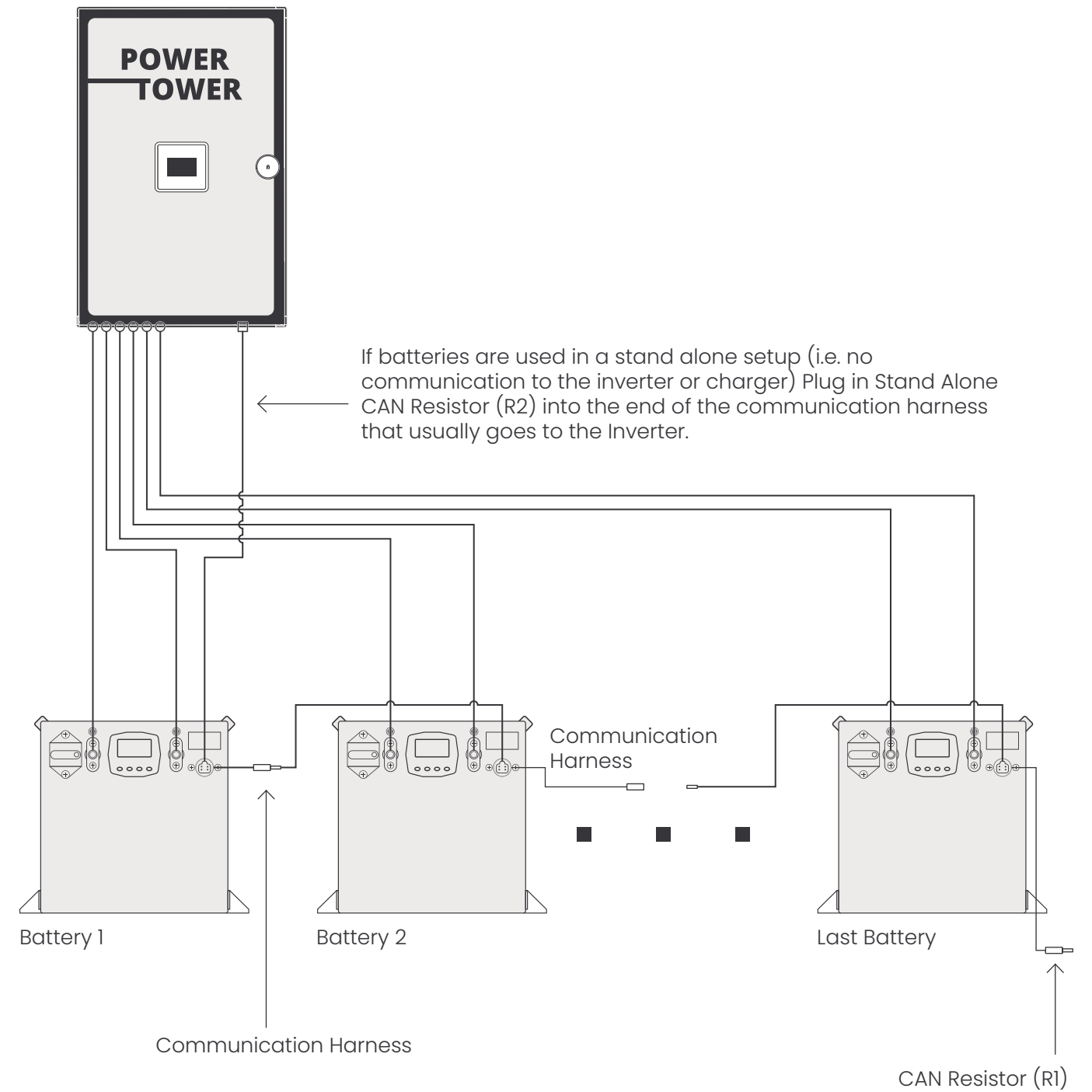

9.4. Communication Harness

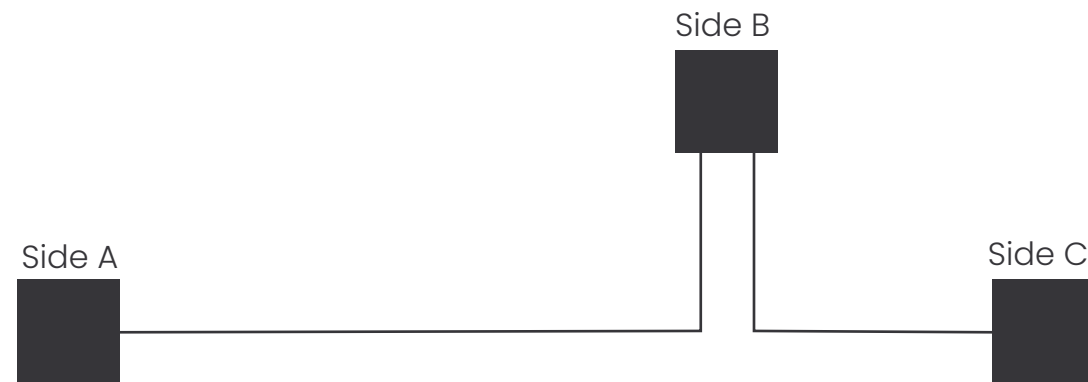

Communication Harness

1. For the first battery Connect Side A of the communication cable (Grey Cable Provided):
 - a. The Power Towers Communications connector (a black 4 pin panel mount connection).
 - b. To the SOLARK inverters CAN Line via an ethernet adapter (Provided) into the ethernet port located in the **bold circle**.

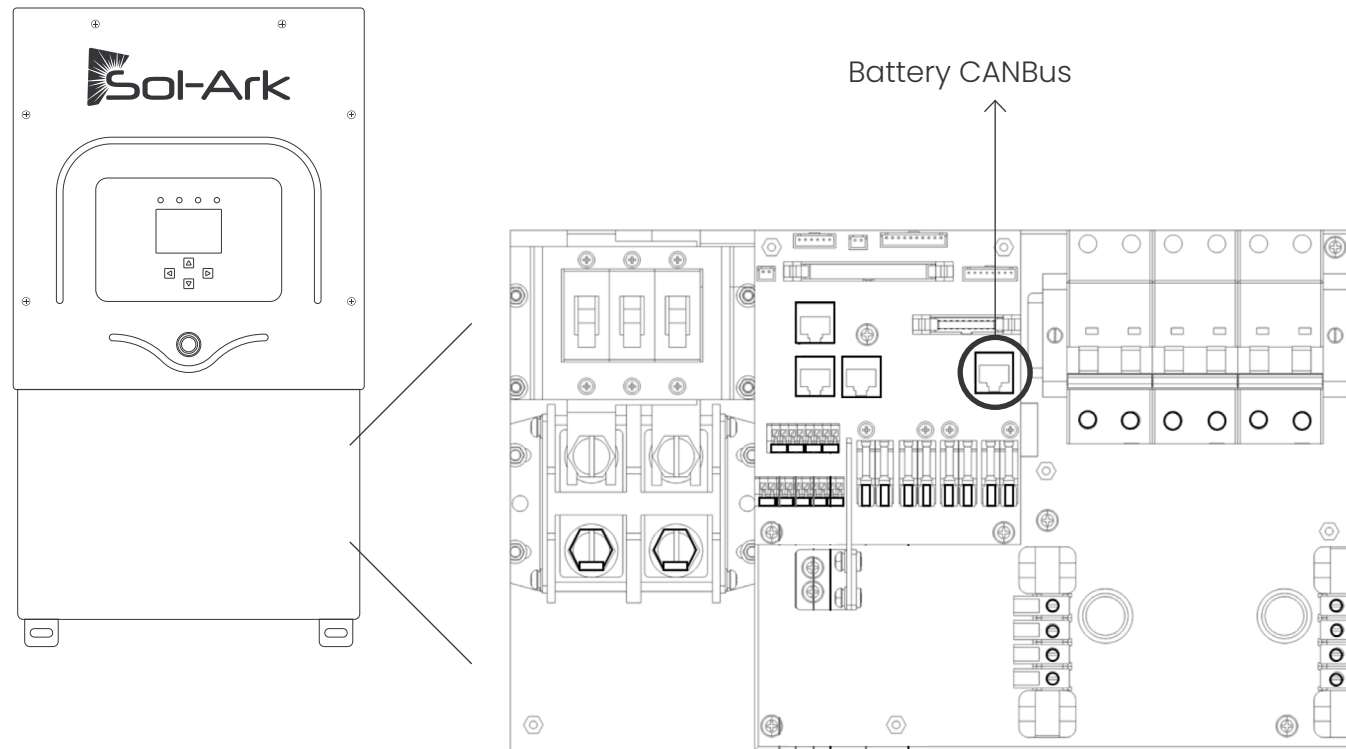

- c. If stand alone (i.e. no communication to a inverter or charger) connect the CAN termination resistor connection R2 (Provided).

2. Connect Side B to the batteries COM port (Located under the OFF-ON-START Switch)



3. Connect Side C to
 - a. If only 1 battery Plug in Termination resistor R1
 - b. If More than one battery is use, plug Side A of the Communication cable from the next battery into the first batteries side C. Continue connecting all parallel batteries Side A into the previous batteries communications cable side C . Once all the batteries are connected via connector A and C, Plug in Termination resistor R1 to the last battery's Connection C to complete the circuit
4. Once all the batteries communications cables are connected, connect all positive leads to the inverter/charger then all the negative leads
5. Turn on all the batteries and wait 5 seconds after all are turned on for the batteries to settle
6. Turn on the load

RAPID SHUTDOWN CIRCUIT/ E-STOP CIRCUIT

SECTION 9

The Power Tower and PT 14 can be outfitted with a rapid shutdown circuit/ Emergency Stop circuit Via the PT14's communication harness. These emergency circuits can be added to the power towers provided R2 Connector, alterations can be made Using **Pin 1** and **Pin 4**, on this connector there is a blue wire that can be spliced.

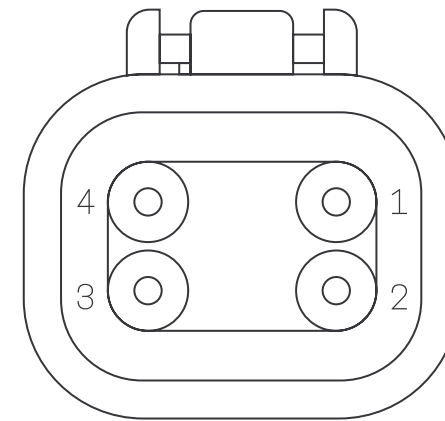

Side A of the communication harness

Pin 1 is 48VDC Out

Pin 2 is CAN Low

Pin 3 CAN High

Pin 4 is 48VDC IN

Pin 1 and Pin 4 are to be wired to an emergency button or Switch that will short Pin 1 and 4 together under normal operation but will disconnect Pin 1 from 4 when pressed.

The Circuit is below:

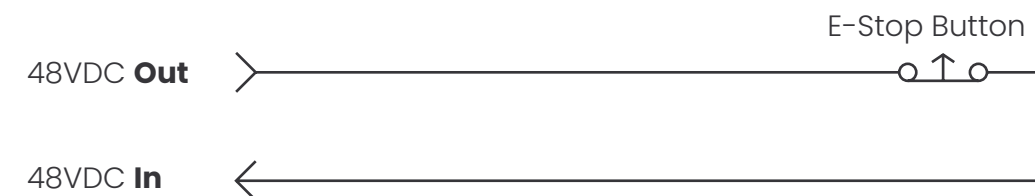

Be very careful when wiring the E-Stop Circuit to not wire Pin 2 or Pin 3 to either Pin 1 or Pin 4, as Pins 2 and 3 are low voltage and are meant for communication. The introduction of 48VDC to either of these pins will damage the electronic components in the PT14 and any device that is connected to the communication line.

Discharge at different rate

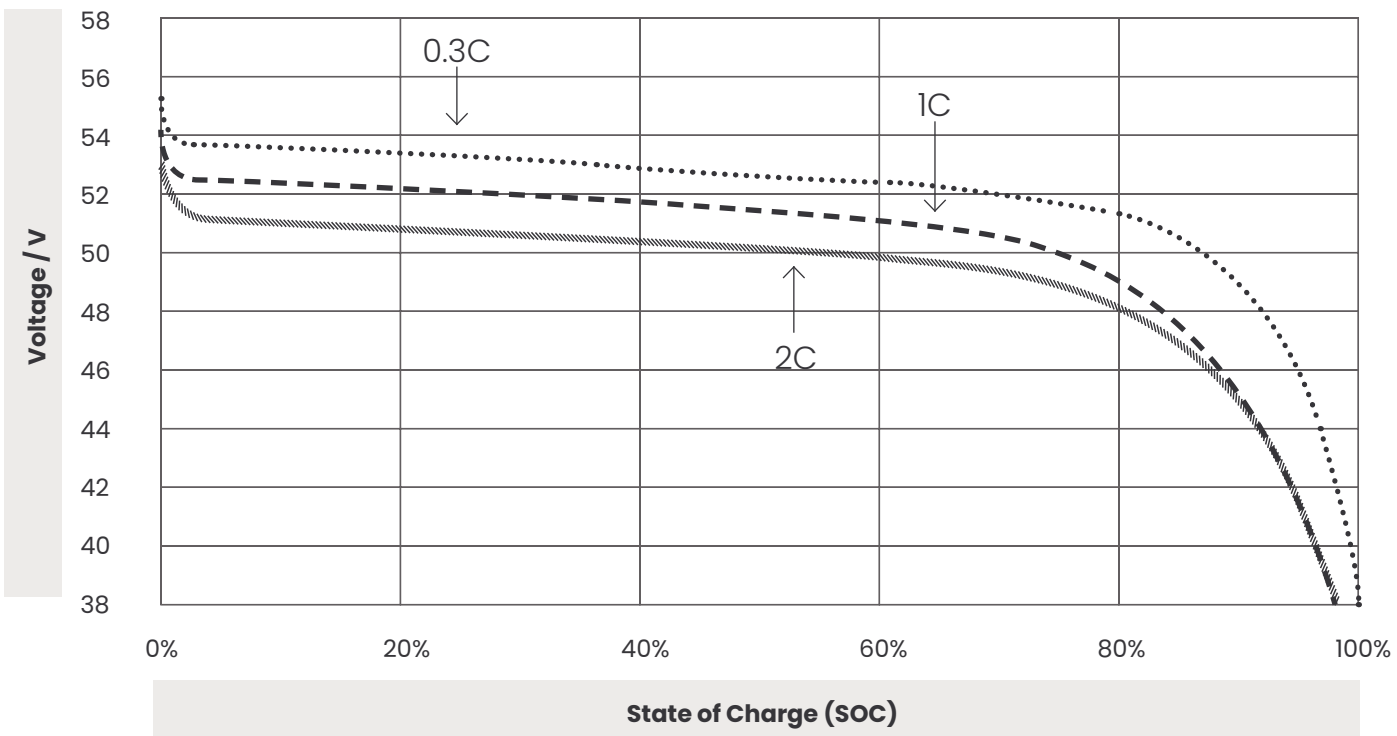

safe operation voltage range



[This page intentionally left blank]

[This page intentionally left blank]

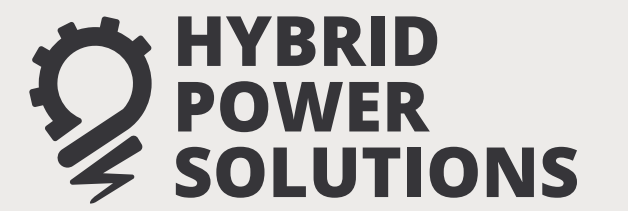

PT BATTERY 14



**HYBRID
POWER
SOLUTIONS**