

BATT PACK JUPITER

User Manual

Manufactured by:
**HYBRID
POWER
SOLUTIONS**

288 Judson St #5
ON M8Z 5T6

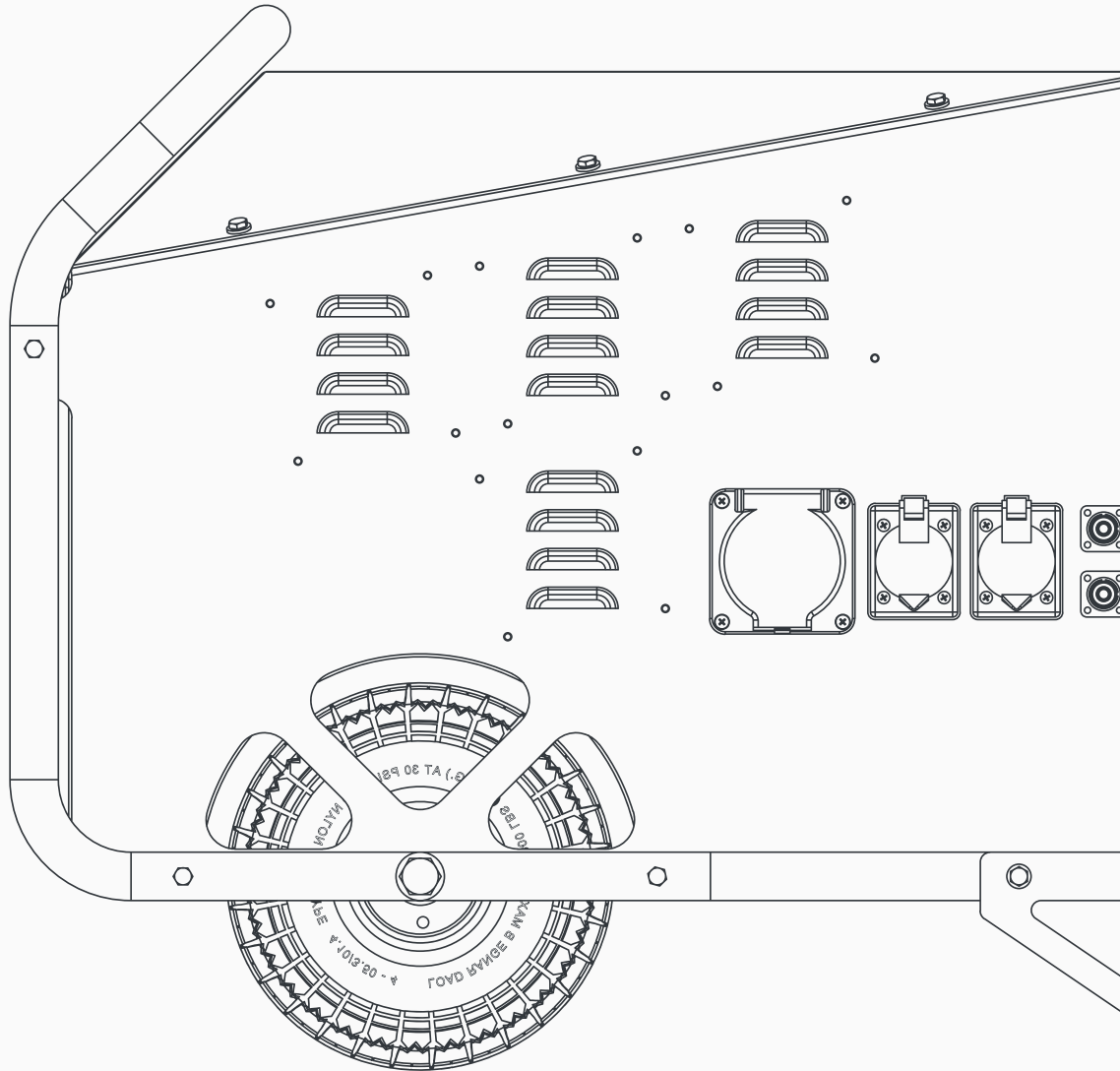



**HYBRID
POWER
SOLUTIONS**

[This page intentionally left blank]

BPJ BATT PACK JUPITER

 **7000**

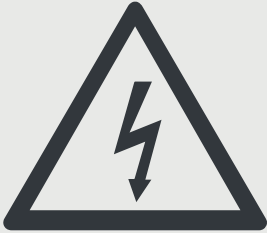

SHOCK HAZARD:

Possible shock or death if used improperly, when damaged or used by untrained personnel.



FLAMMABLE HAZARD:

Lithium ion batteries contain flammable liquid electrolyte that may vent, ignite and produce sparks when subjected to high temperatures ($> 150\text{ }^{\circ}\text{C}$ ($302\text{ }^{\circ}\text{F}$)), when damaged or abused (e.g., mechanical damage or electrical overcharge). Burning cells can ignite other batteries in close proximity.

Vapors or mists from a ruptured battery may cause respiratory irritation.

Manual

INDEX

Content	Page
Introduction	08
Safety Information	10
Configuration	13
Operation	18
Troubleshoot	22
Warranty	24

INTRODUCTION

Section 1

1.1. Product Description

Thank you for choosing this portable power supply from Hybrid Power Solutions (HPS). We hope you enjoy and use the Batt Pack to its full potential.

Please unpack your Batt Pack Jupiter carefully and check the delivery for completeness and obvious damage. In case of damage inform us immediately.

The Batt Pack Jupiter is delivered to you in a ready to use state with 30% energy (+/- 5%). However, please make sure you read through this user manual carefully. If you have further questions regarding the Batt Pack, please contact HPS.

1.2. Contact Details

Hybrid Power Solutions Inc.

Customer Service/ Technical Support
288 Judson St Unit #5, Toronto, ON M8Z 5T6
Canada

Phone: +1 (647) 347-6000
E-Mail: Info@hybridps.ca
Website: hybridps.ca

SAFETY INFORMATION

Section 2

2.1. General Safety Instructions

Before operating the Batt Pack Jupiter, carefully read and fully understand the instructions including all the cautions and safety notices shown on the second page of this manual. Following all instructions for proper operation and troubleshooting will reduce the risk of personal injury, death and/or property damage.

These instructions are not intended as a complete list of all details for operating and troubleshooting, although reading and following them will aim to keep you safe. If you have any questions or concerns about procedures or safety that are not covered by these instructions, do not hesitate to contact HPS.

2.2. Operator Responsibility

Treat the Batt Pack Jupiter system with general care, by closing the output plugs and input plugs and turning the system off when not in use.

If an unfamiliar sound or smell is noted to come from the unit, please turn off the unit and notify HPS immediately. Leave in a well-ventilated area, away from flammable sources.

WARNING: Do not put fingers and/or any other object into the units plugs.

Never open the unit case.

Do not expose to temperatures outside the range of -40°C to 50°C .

To minimize any adverse effects on battery performance it is recommended that the system be kept at room temperature ($25^{\circ}\text{C} \pm 5^{\circ}\text{C}$). Low or elevated temperatures can result in shortened cell life.

Keep out of reach of children.

GFCI WARNING: Although the Batt Pack Jupiter does have circuit interruption built into the design, we highly recommend the use of a GFCI adapter in certain situations. This adapter can be supplied by HPS or other reputable suppliers. We do not include a GFCI as the Batt Pack may be used in various scenarios that either do, or do not require this device. The following is a general outline from the National Electrical Code (NEC). Please review the entire NEC documentation pertaining to this matter to help with your decision-making process.

Commercial GFCI Requirements (NEC 2014 Excerpt)

- All 125-volt, single-phase, 15- and 20-ampere receptacles installed in bathrooms, kitchens, rooftops and outdoors, 6' from a sink, indoor wet locations, locker rooms, garages, service bays, and similar areas.
- All vending machines.
- All pool motors, spas, and pumps.
- All electric drinking fountains.
- Exceptions:
 - In industrial laboratories, receptacles used to supply equipment where removal of power would introduce a greater hazard shall be permitted to be installed without GFCI protection.
 - For receptacles located in patient bed locations of general care or critical care areas of health care facilities other than those covered under 210.8(B)(1), GFCI protection shall not be required.
 - Receptacles that are not readily accessible and are supplied by a branch circuit dedicated to electric snow-melting, deicing, or pipeline and vessel heating equipment shall be permitted to be installed in accordance with 426.28 or 427.22, as applicable.
 - In industrial establishments only, where the conditions of maintenance and supervision ensure that only qualified personnel are involved, an assured equipment grounding conductor program as specified in 590.6(B)(2) shall be permitted for only those receptacle outlets used to supply equipment that would create a greater hazard if power is interrupted or having a design that is not compatible with GFCI protection.

2.3. Condition of Use

If system is in abnormal physical condition, do not use.

Critical Errors

If power button is pushed ON and the unit does not turn ON, please plug in to grid power and allow to recharge for a minimum of 10h. If the unit does not turn ON, please contact HPS technical support for further assistance.

If internal components are heard/ believed to be loose inside/ rattling, please call HPS technical support.

CONFIGURATION

Section 3

3.1. Overview

The Batt Pack Jupiter is an industrial, high performance, weather resistant lithium ion battery pack that is designed to be safe and easy to operate.

Designed to deliver the full potential of batteries by delivering 7,000W of power. With an average life cycle of 5 to +10 years (depending on usage).

3.2. Technical Specifications of the Batt Pack Jupiter

Battery Specifications

Nominal Battery Voltage	25.2VDC
Minimum Battery Voltage	20VDC
Maximum Voltage	29.2VDC
Total Energy	7.88 kWh
Usable Energy	7.5 kWh
Charge Time	~6.25h
Cycles (80% DOD at 1C)	3,000

Output Specifications

Continuous Power Output	7,000VA
Maximum Power Output (3min)	9,000VA
Maximum Peak Power (0.2sec)	12,000VA
AC Waveform	Pure Sine Wave
Output Voltage(s)	120VAC and 240VAC
120VAC Output Plugs	5-20R (Max 20A)
240VAC Output Plug	L14-30R (Max 30A)

Input Specifications

Input Voltage	120VAC (60hz)
Input Power	1,400W
Input Plug	5-15P

Physical Specifications

Dimensions	91.4cm x 68.5cm x 58.4cm [36in x 27in x 23in]
Weight	127 kg [280 lbs]
IP Rating	54
Storage Temperature	-30 °C to +70 °C (-22 °F to 70 °F)
Operating Temperature	-20 °C to + 45 °C (-4 °F to 113 °F)
Charging Temperature*	0 °C to + 40 °C (32 °F to 104 °F)
Wheel Diameter	10" (254 mm)
Wheel Qty	2
Minimum Ground Clearance	4" (100 mm)

*Optional cold weather package available at additional charge. Allows for charging at -20 °C to + 45 °C (-4 °F to 113 °F).

3.2. Power Restrictions

The Jupiter unit can output 7000VA continuous and a maximum of 12000VA for 0.2 seconds through its three outputs (one 240VAC and two 120VAC). The 240VAC plug can output 7000VA Continuous (240VAC being used solely), while the 120VAC plugs can output 3500VA each (when only the 120VAC plugs in use). The maximum output per 120VAC plug should be limited to 20A continuous based on plug rating. In the case that the 240VAC plug and one 120VAC plug is being used, the continuous power available to the 120VAC plug can be calculated using the following equation:

$$\frac{P_{240VAC}}{2} + P_{120VAC} \leq 3,500V A$$

In the case that this power draw is exceeded, the unit will beep stating that it is overloaded (above 3500VA). The unit will still operate but for only for a limited period. In the case that all three plugs are used the combined total output should be 7000VA and the unit will beep if the combined total exceeds 7000VA.



3.3. Batt Pack Jupiter General Dimensions

Appearance may deviate slightly due to ongoing innovation.

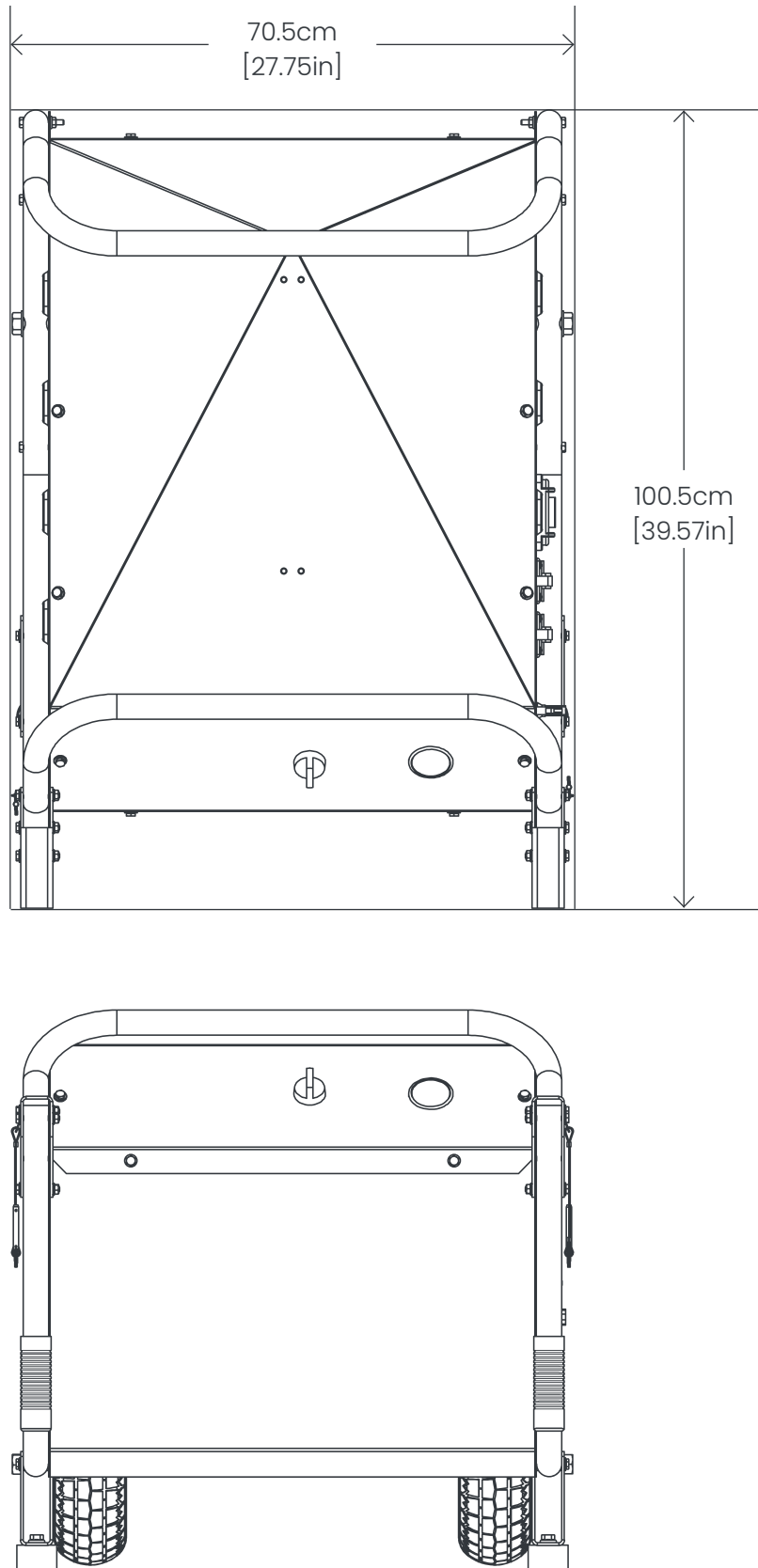

Appearance may deviate slightly due to ongoing innovation.

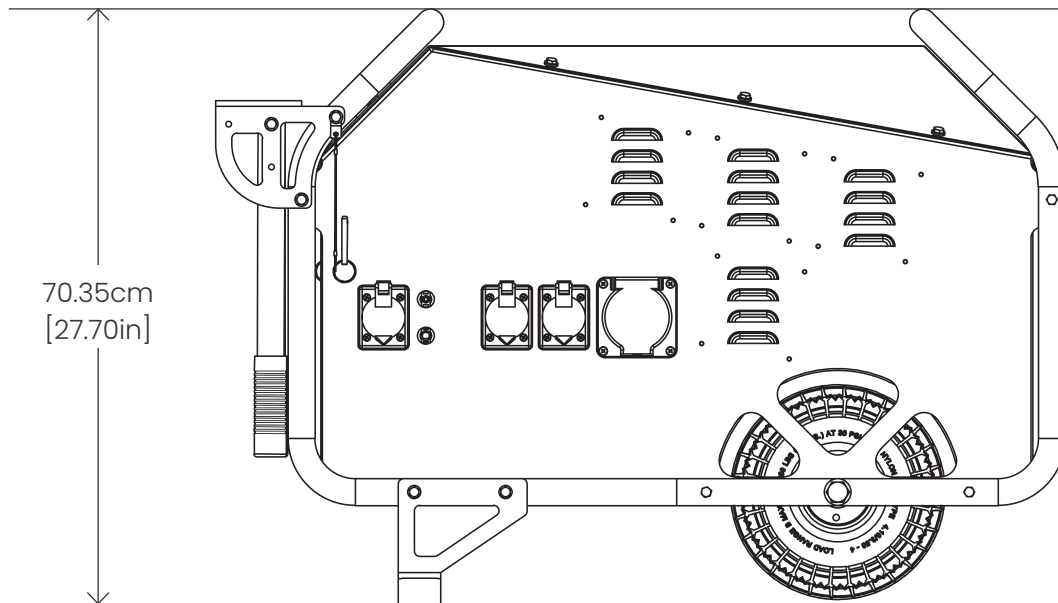
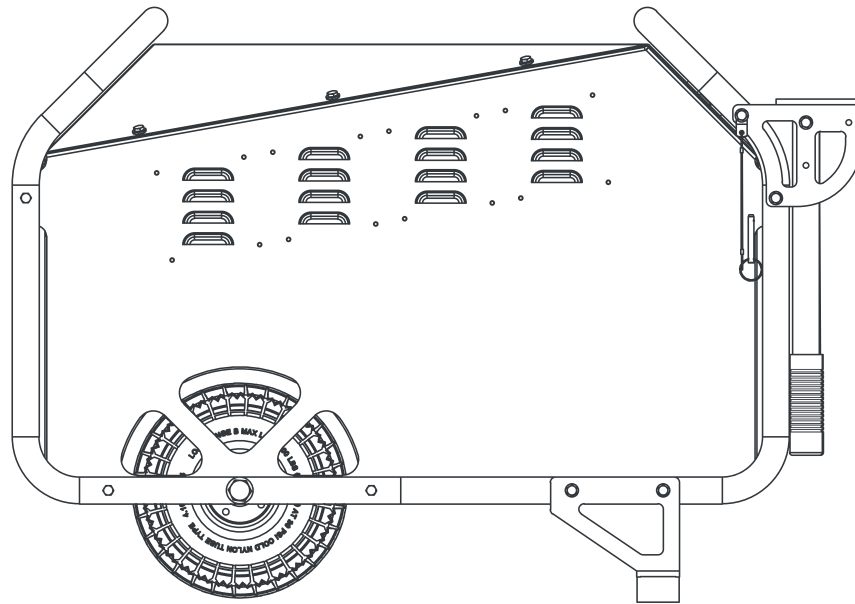

OPERATION

Section 4

4.1. General Operation

The plug cover should always be used to protect the plug from corrosion and other environmental factors.

The system should always be left in the OFF position when not in use. In the ON position, very little power is consumed but will slowly deplete the battery. HPS recommends always turning off the Batt Pack when not in use.

When using the system in cold temperatures (below 0°C), discharge power may be limited and run time can be affected by up to 40%. The product will naturally warm itself with usage and improve capabilities. For maximum capacity and performance, ensure the Batt Pack is stored at room temperature (25°C) then brought out into colder climates. **A cold weather package can be purchased when ordering and is recommended when charging and discharging in sustained temperatures lower than -5°C.**

The Batt Pack will not allow a discharge to occur after being fully depleted until the system has been charged to passed 10%.

Master disconnect switch – A master disconnect switch is installed on the Batt Pack series to further protect the integrity of the battery while in storage.

When in use, the master disconnect switch should be turned ON and left ON.

The master disconnect switch should be in OFF position when the unit is stored inactive for extended periods of time.

The battery should always be stored fully charged with the master disconnect switch in the “off” position.

The unit should be charged at a minimum interval of 3 months. Please note that the gauge will not show any reduction in energy level, even though a minor discharge did occur.

A battery stored fully discharged may permanently damage the product.

WARNING: Do not plug in tools requiring in excess of 20A into the 120VAC plug and 30A for the 240VAC plug. This can cause; damage, shock, injury and/or death. Please use caution when operating tools in wet conditions as this may lead to electrical shock, injury and/or death. HPS is not responsible for damaged or faulty equipment that has been plugged into the Batt Pack Jupiter and has caused an incident.

Using the Batt Pack as a UPS (uninterpretable power source): Always ensure the power button is left in the ON position and the charging port is connected to a main power source (15A circuit minimum). Plug all loads into the output port. This will ensure that if the power from the mains is interrupted, your devices will not be affected. Note that this does use the equivalent of 5–20 battery cycles per month.

WARNING: Always use appropriately sized extension cords and power bars that meet the requirements of your specific application.

4.2. Break in Period

WARNING: Although the battery system is delivered balanced, below advertised performance may be present during the first 5 cycles (charge and discharge). As the cells in the battery module equalize to within +/- 0.01V. This is completely normal and is the nature of Lithium ion batteries. Use the unit as normal but do acknowledge this break in period.

Ideally during this break in period, HPS recommends the unit be charged to 100%, then left on the charger for +2 hours afterwards. This will give the cells a chance to balance in order to achieve optimal performance. We also recommend not to discharge past 25%. This recommended break in habit is to insure optimal performance as quickly as possible.

Not following this break in recommendation will not damage the system but may lead to the gauge back-light turning off (indicating an error). As the system will acknowledge the imbalance. It may also delay achieving peak performance.

4.2. Recharging Guide and Storage

Charge using a regular single ended extension cord rated for 15A minimum. Always charge the unit on a dedicated electrical circuit. HPS recommends a minimum 12AWG extension cord. Do not use adapters for charging purposes and do not run the extension cord off a power bar.

After the break in period concludes, charge and discharge as desired.

Charge Batt Pack within 72 hours of complete discharge with power button off.

If the master disconnect switch is always left ON, charge a minimum of once a month in order to ensure the energy level does not fall to damaging levels.

It is safe to leave the Batt Pack plugged into the charger for extended periods of times as long as the power button has been turned OFF.

The battery can be charged with the power button either ON or OFF. We recommend keeping the system in the OFF position when not being discharged, as an energy saving practice.

4.4. Transporting and Shipping

If shipping units is required, please ensure to list the Batt Pack with your shipper as a hazardous goods and follow all required precautions and regulations. The Batt Pack is a UN38.3 certified, class UN3481 (lithium ion battery in equipment). It is the shipper's responsibility to ensure all paperwork and required packaging is in order. HPS can help guide you through the process.

4.5. Maintenance & Cleaning

WARNING: HPS does not recommend using a pressure washer to clean the unit as this may damage the internals and void the warranty. Always ensure that the plug caps are closed, and the system is OFF when washing.

Always make sure to turn OFF unit when not in use and to keep the unit in charged state.

No user maintenance is required. Periodic system checks can be performed by an authorized HPS representative.

4.6. Extreme Temperatures & Fan Operation

Using the product in extreme temperatures, above 45°C and below -20°C may reduce the total life cycles of the product. The warranty does not cover such usage.

We always recommend charging the Batt Pack Jupiter in temperatures above 0°C. Charging below this may reduce cycle life.

Note that performance may be affected in temperatures under 0°C. Run time can be reduced as well as available power.

To improve performance in cold weather scenarios, HPS suggests storing and charging the system at room temperature before exposing to cold temperatures.

An optional cold weather package is also available at the time of purchase and is recommended for sustained conditions under -5°C.

Fans operate when the internal temperature of the system is higher than 36°C. This generally occurs in warmer climates and when the battery is being charged or is being discharged at a high-power output.

4.7. Starting Motors

Please exercise caution when powering motors with the Batt Pack Jupiter. Most motors require 2-3 times their continuous operating amperage at start up. Certain motors may require more amperage than can be produced. Note that the surge power of 12,000kVA is only sustained for 20ms and may not be long enough for some motors. Motors with a soft start feature may help to reduce this inrush current.

Please note that Hybrid Power Solutions Inc. is not responsible for damaged tools, equipment or electronics.

4.8 Dusty Environment

A dust and water filter is included for both the intake and exhaust. If working in dusty environments for extended periods of time, it may be necessary to clean the air filter. An HPS authorized distributor or Hybrid Power Solutions will be able to assist with this.

TROUBLESHOOT

Section 5

5.1. Fuel Gauge Backlight/Audible Warning Interpretation

LED Backlight	Meaning
Solid Red	Discharge mode
Solid Yellow	Charger Plugged (button off)
Low repetitive audible “beep” (operational)	Cold/hot weather warning or low battery warning
Rapid repetitive audible “beep” (non-operational)	Fault detected, short circuit, power overload, critically low battery

5.2. Problem and Solution Table

Problem	Solution
Charger plugged but unit not turning ON	<ul style="list-style-type: none"> • Check to ensure power is live from extension cord. • Battery may be fully depleted and in protection mode. An authorized technician will need to revive the unit.
Audible warning is heard	<ul style="list-style-type: none"> • Unit is low on energy. Recharge. • Power demand exceeds rated capacity. Reduce load. • Temperature of unit is too high, let unit cool down. Gauge backlight will be off as well. • Fault or Short Detected. Remove load immediately and inspect.
Power Button ON and operating but gauge is OFF	<ul style="list-style-type: none"> • Battery temperature is beyond operating limits. Allow unit to cool if overheat is assumed. If unit is too cool, plug unit in for charging in heated space. If problem persists after a charge cycle, call HPS for diagnostic.
Power Button ON but gauge is off and no power is being output	<ul style="list-style-type: none"> • Critical fault has occurred. Reset by turning system OFF for 120 seconds. Plug into shore power for charging. If the problem is not corrected, contact HPS for diagnostic. • Left ON pass safe discharge point, leave unit plugged in for +20min to revive
Gauge is red, but charger is plugged in	<ul style="list-style-type: none"> • The power button will override the yellow charging light, rest assured the unit is still charging.

WARRANTY

Section 6

9.1. Manufacturer's Warranty Coverage

All Batt Packs supplied by Hybrid Power Solutions are tested for reliability and performance before delivery for correct function and condition.

We grant no warranty or liability for defects and losses that occurs during the use by the customer.

Please refer to this user manual to ensure proper user operation and operating conditions, which will ultimately prolong the life of the Batt Pack unit. The warranty does not cover negligence to this manual's directions.

Hybrid Power Solutions (HPS) warrants its products against defects in material and workmanship. Under normal use and service, every hardware portion of the product will be free from physical defects in material and workmanship during the warranty period, or the product will be repaired or replaced as determined solely by HPS. HPS provides a limited warranty for its products only to the person or entity that originally purchased the product from HPS or its authorized distributor or retailer.

9.2. Owner's Warranty Responsibility

If the product does not operate as warranted above during the applicable warranty period, HPS shall, at its option and expense (except for shipping cost), repair the defective product or part, deliver to the customer an equivalent product or part to replace the defective item. All products that are replaced will become the property of HPS. Replacement products may be new or reconditioned as determined by state of the original unit.

COMMERCIAL WARRANTY PERIOD (UNLESS OTHERWISE CONTRACTED) IS SIX (6) MONTHS.

BATTERY WARRANTY PERIOD IS SET AT 24 MONTHS OR 500 CYCLES (WHICHEVER OCCURS FIRST) AND ONLY COVERS THE BATTERY MODULE.

9.3. Exclusions

Warranty does not apply, if

- The warranty period is expired,
- The warranty label is broken or removed,
- The serial number label is missing or unrecognizable,
- The product has been modified, opened or repaired by any unauthorized service center or personnel,

- The defect was subject to abuse, improper use not conforming to product manual instructions, or environment conditions more severe than those specified in the manual operating condition and user operation.
- The G Shock sticker has been triggered. (50G)
- The water tape indicator has been triggered.

9.4 Recycling

Please return the product to HPS for safe recycling. If the battery within the system is suspected to be damaged, please recycle at the closest electronics recycling facility.

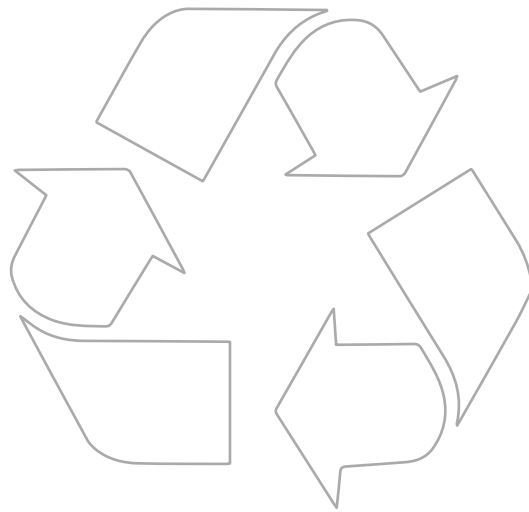



**HYBRID
POWER
SOLUTIONS**

BATT PACK JUPITER

BATT PACK JUPITER
7000

**HYBRID
POWER
SOLUTIONS**