



MOTOPULVERIZADORA
van Beek 3vB-14T TURBO BOOST

**MANUAL DE
USUARIO**



Felicitaciones por adquirir tu

Motopulverizadora van Beek TURBO



COMENCEMOS

Tabla de contenidos

Tabla de contenidos.....	3
Contenido del paquete.....	4
Contenido de montaje.....	5
- Conjunto de líquido de niebla.....	6
- Ensamblaje de líquido Tree Top.....	8
Advertencias y precauciones de seguridad.....	10
Alimentando.....	11
Guía de arranque.....	12
Detener su motor.....	13
Adición de productos químicos.....	14
Opciones de ajuste.....	14
Especificaciones técnicas.....	15
Funciones y uso.....	15
Solución de problemas.....	16
- Guía de ajuste del carburador.....	16
- Reparación rápida del tanque con fugas.....	17
- Más resolución de problemas.....	18
Manual de repuestos.....	22

Contenido del paquete



OPCIONAL



OPCIONAL



van Beek 3vB-14T BACKAPACK FOOGER

- A. TUBO ACANALADO
- B. TUBO DE CONEXIÓN
- C. TIPO DE VENTILADOR
- D. BOQUILLA DEL VENTILADOR
- OPCIONAL 1: TUBO DE EXTENSIÓN
- OPCIONAL 2: TUBO CODO

PARTES ADICIONALES

- 2 TUBOS CLAROS
- 2 ABRAZADERAS PARA MANGUERAS
- 1 TANQUE DE POLVO
- 1 TUBO POLVO
- 1 PANTALLA
- 1 CADENA DE PUESTA A TIERRA

Ensamblaje estándar Parte 1



1 Retire todas las piezas de la caja del atomizador, incluida la bolsa del kit de herramientas.



2 Fije el tubo estriado (A) al codo del soplador



3 Asegure el tubo estriado con una abrazadera de manguera al codo del soplador



4 Conecte el tubo de conexión (B) y asegúrelo al tubo estriado con una abrazadera de manguera



5 Conecte el tubo del soplador (C) uniéndolo al hoyuelo elevado a la guía de la ranura



6 Gire para bloquear en su lugar

Ensamblaje estándar Parte 2



7 Conecte la boquilla del ventilador (D) al extremo del tubo del ventilador



8 Deslice la manija del acelerador sobre el tubo de conexión (B) y apriete con el tornillo del juego de herramientas



9 Conecte el tubo superior de la bomba turbo a la base del tanque químico



10 Asegure el otro tubo de la bomba a la parte trasera del acelerador y el segundo tubo al frente



11 Envuelva el segundo tubo alrededor del tubo del ventilador (C) y conecte su extremo a la boquilla del ventilador (D)



12 To begin fogging, add 50:1 Pre Mix Fuel (fuel not included)

Ensamblaje de la copa del árbol, parte 1



1 Retire todas las piezas de la caja del atomizador, incluida la bolsa del kit de herramientas.



2 Fije el tubo estriado (A) al codo del soplador



3 Asegure el tubo estriado con una abrazadera de manguera al codo del soplador



4 Conecte el tubo de conexión (B) y asegúrelo al tubo reforzado con una abrazadera de manguera



5 Conecte el tubo del soplador (C) uniendo el hoyuelo elevado a la guía de la ranura



6 Gire para bloquear en su lugar

Ensamblaje de la copa del árbol, parte 2



7 Conecte el tubo acodado al tubo del ventilador (C) y asegure la boquilla del ventilador (D) en su extremo



8 Deslice el acelerador sobre el tubo de conexión (B) y apriete con el tornillo del juego de herramientas



9 Conecte el tubo superior de la bomba turbo a la base del tanque químico



10 Asegure el otro tubo de la bomba a la parte trasera del acelerador y el segundo tubo al frente



11 Para comenzar a empañar, agregue 50: 1 Mix Fuel (Combustible no incluido)



12 Para comenzar a empañar, agregue 50: 1 Mix Fuel (Combustible no incluido)

PRECAUCIONES Y ADVERTENCIAS DE SEGURIDAD

Precauciones para el operador

- 1.- Este producto emite monóxido de carbono, una toxina invisible e inodoro. No utilice este producto en interiores en ningún momento.
- 2.- Siempre apague el motor antes de agregar combustible al tanque.
- 3.- Para evitar electrocutarse, no tocar la tapa de la bujía ni el cableado mientras el motor está encendido.
- 4.- No tocar la superficie del silenciador y el cilindro con el motor en marcha. Hace mucho calor

Advertencias del equipo

- 1.- El motor de 2 tiempos 3vB-14T funciona con una mezcla de combustible 40:1 Utilice gasolina de 91 octanos y aceite de motor de dos tiempos. Nota: El combustible premezclado 40:1 es ideal para este producto ya que contiene estabilizadores de combustible para garantizar la amabilidad del equipo.
- 2.- Después de arrancar el motor, mantenga el acelerador a baja velocidad durante varios minutos antes de ponerlo en marcha a fondo.
3. La gasolina es un combustible extremadamente inflamable. Cuando esté en funcionamiento, manténgase alejado de las llamas. No fume durante el funcionamiento.
4. No rocíe en la dirección de otros.

Manipulación de productos químicos.

- 1.- Use protección para los oídos.
- 2.- Use protección para los ojos.
- 3.- Utilice una mascarilla para protegerse la boca y la cara contra el polvo y los pesticidas.
- 4.- Llevar calzado de protección con punta cerrada.
- 5.- Use guantes para evitar el contacto con pesticidas.
- 6.- Use ropa adecuada para proteger brazos y piernas para evitar el contacto con pesticidas.
- 7.- Después de la pulverización, lávese las manos y la ropa inmediatamente.

COMBUSTIBLE

- Este motor está certificado para funcionar con gasolina sin plomo y aceite de motor de dos tiempos en una proporción de mezcla de 50: 1.
- Este motor requiere una mezcla de gasolina de alta calidad y aceite de motor de 2 tiempos enfriado por aire.
- Utilice gasolina sin plomo de grado medio con un octanaje mínimo de 91 y un contenido de etanol no superior al 10%.
- Mantenga el tanque de combustible alejado de llamas o chispas. No fume cerca del combustible.
- Cuando agregue combustible premezclado al motor, use un embudo para evitar derrames.
- Cuando la máquina esté funcionando, no agregue más al tanque de combustible.
- Abra la tapa de combustible con cuidado para permitir que la presión acumulada en el tanque se libere lentamente y evitar derrames de combustible.
- Al final de una temporada, drene todo el combustible del tanque de gasolina y use estabilizador de combustible para asegurar un carburador limpio para la próxima temporada.

**ATENCIÓN: USE ÚNICAMENTE COMBUSTIBLE PARA MOTORES DE 2 TIEMPOS PREMIX 50: 1
O UNA COMBINACIÓN 50: 1 DE 93 OCTANOS DE GASOLINA Y 2 ACEITE DE MOTOR DE CARRERA**

Guía de inicio



1 Llene el tanque de combustible con un combustible premezclado 50: 1 de 2 tiempos para una eficiencia óptima del motor



2 Mueva la palanca del acelerador a la posición encendido etiquetada "I"

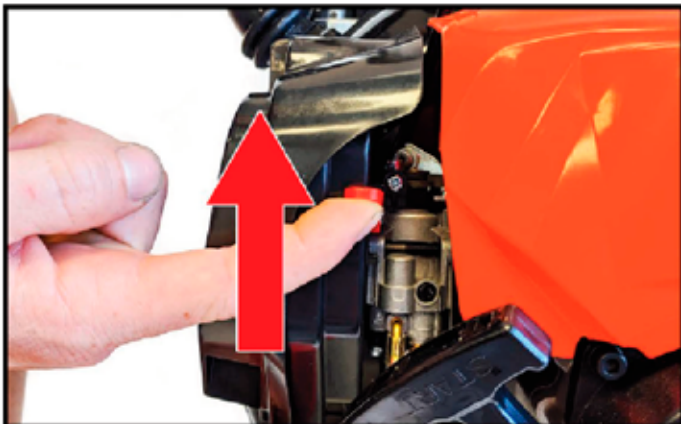

3 Mueva el estrangulador a la posición hacia arriba

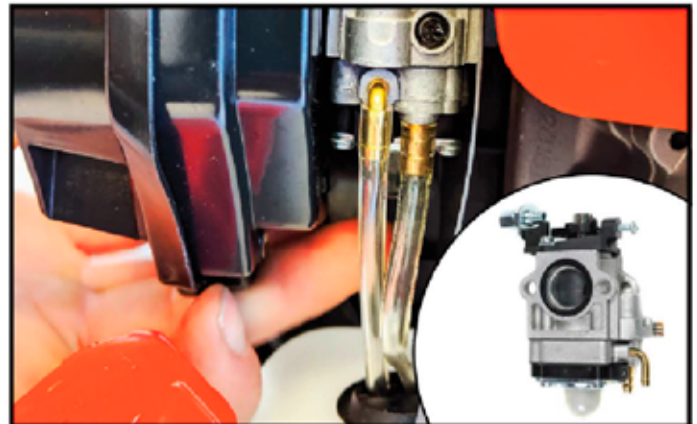

4 Para cebar el motor, presione el bulbo del carburador 4-5 veces o hasta que el combustible fluya por las líneas

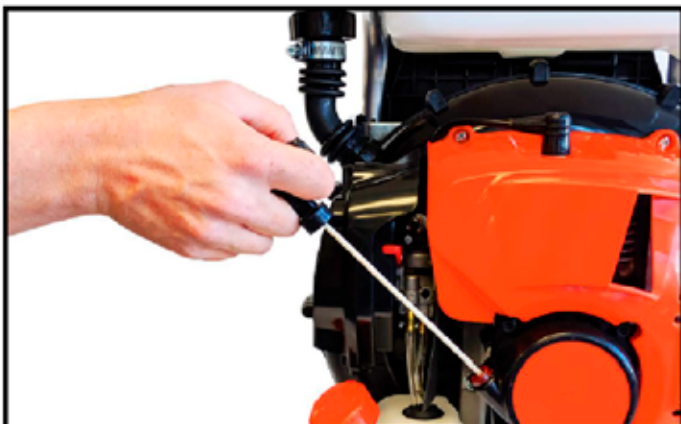

5 Tire del cable de arranque de retroceso hasta que el motor gire y arranque

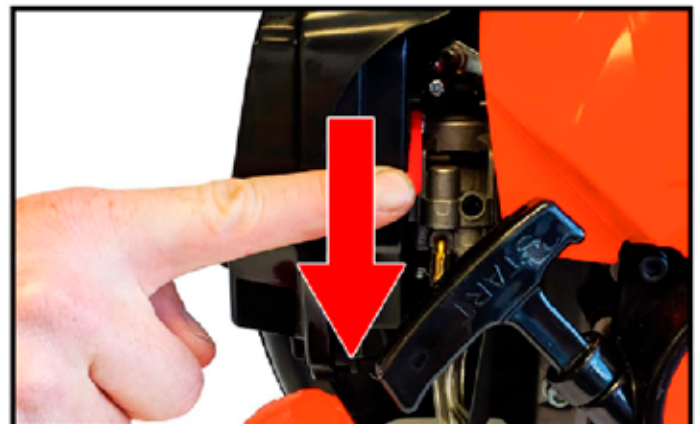

6 Una vez que el motor se enciende, mueva abajo lentamente el estrangulador a la posición hacia

DETENER SU MOTOR

1. Mueva la válvula de agua a la posición cerrada para detener el flujo de líquido. pesticida. Figura 1.
2. Mueva la palanca del acelerador a la posición hacia abajo (O) para detener el motor. Figura 2.
3. Mueva el estrangulador a la posición cerrada. Figura 3.



FIGURA 1



FIGURA 2

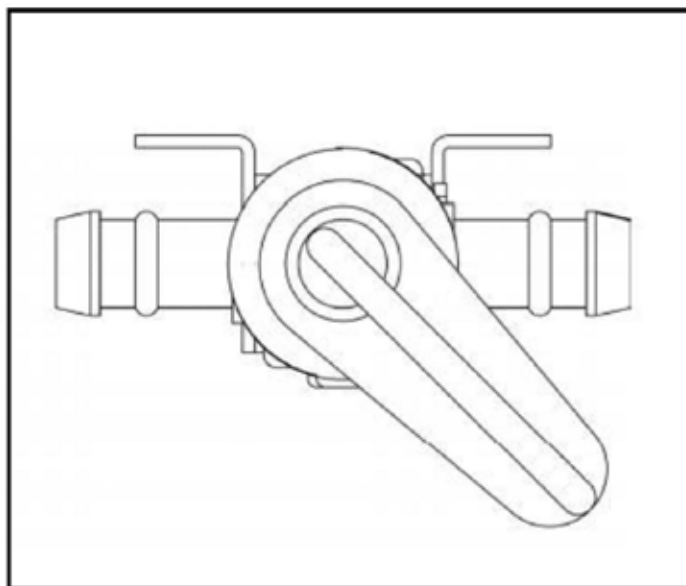

FIGURA 3

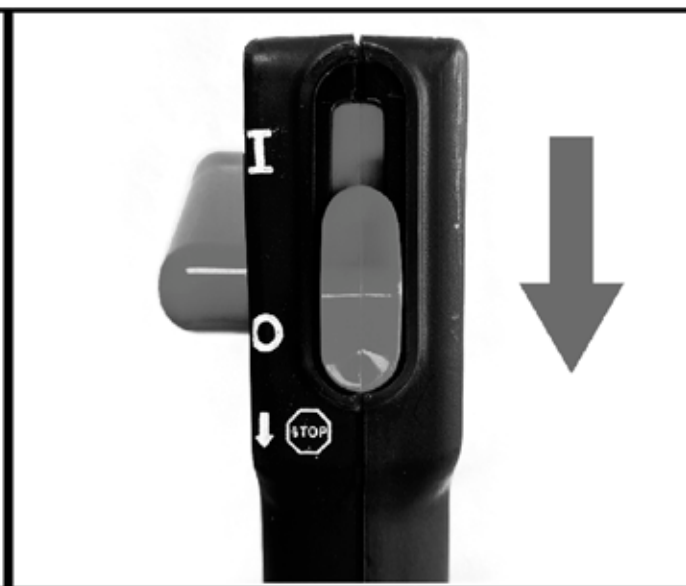

FIGURA 4

AÑADIR PRODUCTOS QUÍMICOS Y AJUSTAR OPCIONES

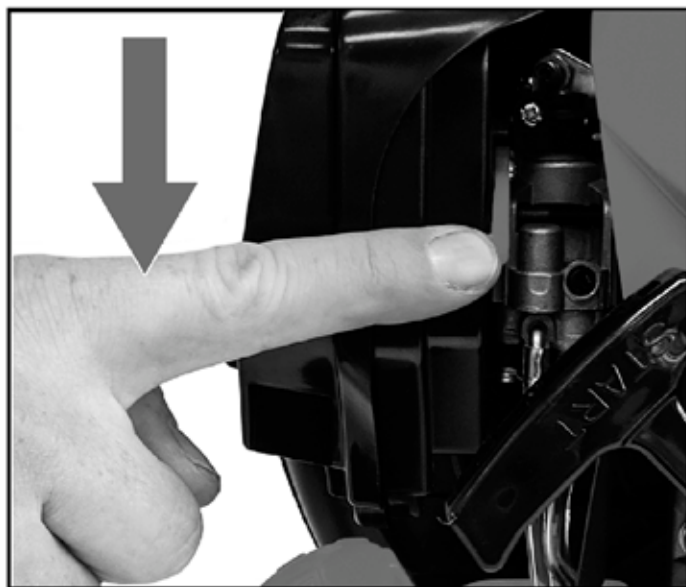
Adición de productos químicos

Advertencia: algunos productos químicos rociados con el atomizador pueden contener sustancias que pueden provocar efectos secundarios graves y lesiones.

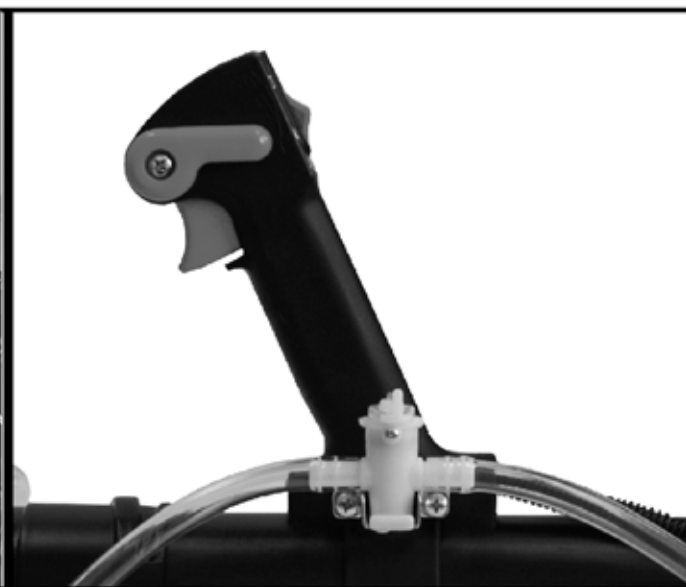
1. Evite el contacto directo con productos químicos y siga siempre las instrucciones del fabricante de productos químicos. Use siempre el ropa adecuada y protección química
2. Es importante diluir sus productos químicos según el producto químico especificaciones del fabricante. Nunca rocíe productos químicos sin diluir.
3. Diluya y prepare sus químicos antes de encender su nebulizador soplador.
4. Prepare su químico y viértalo en el tanque de agua del atomizador. al aire libre o en un área bien ventilada.
5. Después de pulverizar, no mantenga la solución de pulverización en el tanque. Deseche correctamente el exceso de solución de pulverización y enjuague máquina después de cada uso.

Opciones de ajuste

1. Flujo de agua: para ajustar el flujo de agua, use la válvula de agua para aumentar el Flujo de agua del tanque. Ver figura 1.
2. Velocidad del agua: para ajustar la velocidad del agua, utilice el acelerador para aumentar la velocidad del motor. Ver figura 4.
3. Flujo de polvo: para ajustar el flujo de polvo, mueva la palanca hacia la izquierda. Mueve la palanca a la derecha para reducir el flujo de polvo. Ver figura 5.
4. Patrón de pulverización: para ajustar el patrón de pulverización, use la perilla de la bocina. boquilla. 1 es la menor cantidad de flujo y 4 es la mayor cantidad. Ver figura 6.



FIGURA 5



FIGURA 6

ESPECIFICACIONES TÉCNICAS

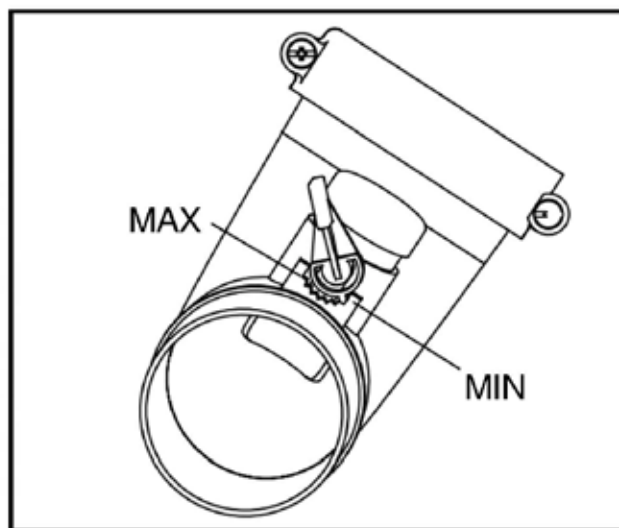
Dimensiones (cm)	45.72 x 30.48 x 66.04
Peso neto (kg)	11
Capacidad del tanque (L)	14
Tamaño de la maquina (cc)	63
La velocidad del motor (RPM)	6500
Potencia del motor (Kw)	1.5
Velocidad del soplador	Más de 200
Tipo de combustible	Recomendado 40:1 Premix o no menos de 30:1 mezclar con aceite de 2 tiempos con gasolina de 91 octanos
Opciones de pulverización	Polvo o líquido
Alcance vertical (m)	7.62 o mas
Alcance horizontal (m)	mas de 12.19 metros

CARACTERÍSTICAS Y USO

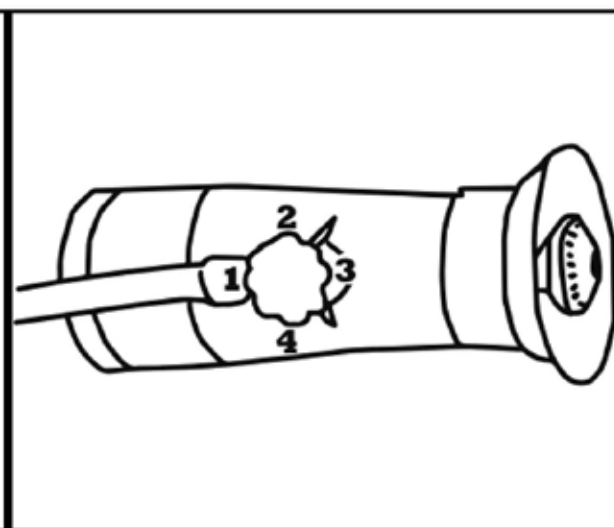
Características	Plagas objetivo	Para uso alrededor
<ul style="list-style-type: none">• Rocíe 1 acre en menos de 30 minutos.• 4 veces más rápido que los pulverizadores de bomba.• Alcance vertical de 7.62 o mas.• Alcance horizontal de hasta mas de 12.19 metros.	<ul style="list-style-type: none">• Mosquitos y garrapatas.• Hormigas y cucarachas.• Orugas y gusanos.• Pulgas.• Moscas que pican y tábanos.• Escorpiones y avispas.• Arañas rojas.• Trips.• Chinchas y escarabajos apestosos.• Y más.	<ul style="list-style-type: none">• Residencial comercial• Granjas y graneros• Lecherías y criaderos• Ganadería• Plantas ornamentales• Huertas• Huertas• Parques y áreas de recreación• Cursos de golf• Y más

Guía de ajuste del carburador



1 Si el motor de su nebulizador se atasca o solo funciona con el estrangulador abierto, siga estos pasos



2 Identifique el carburador del motor entre la tapa del motor y el filtro de aire.

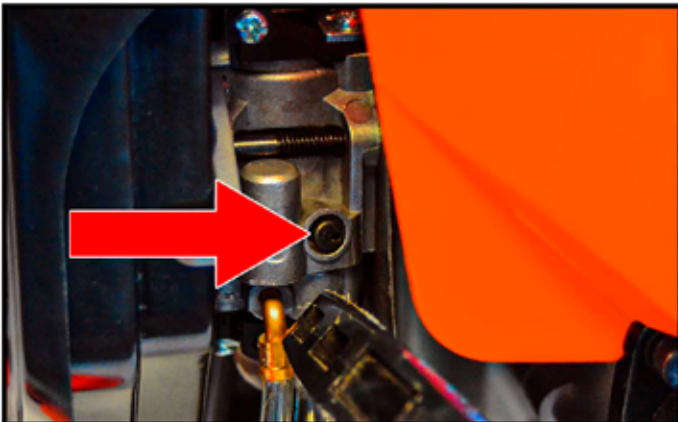

3 Afina tu carburador ajustando el ojo de la cerradura (en la imagen de arriba)

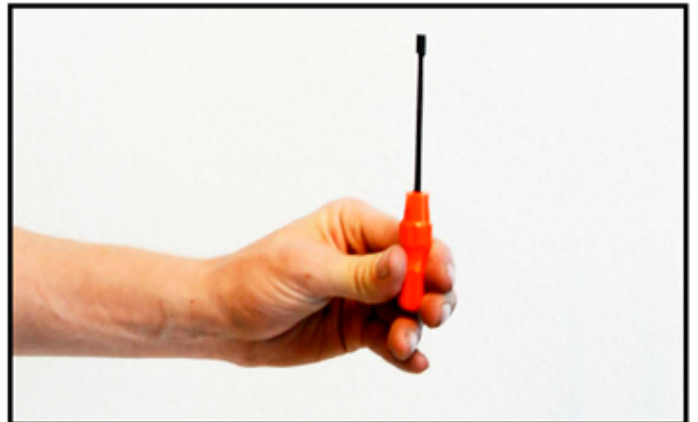

4 Use una herramienta de ajuste del carburador para ajustar el carburador del motor mientras el motor está funcionando

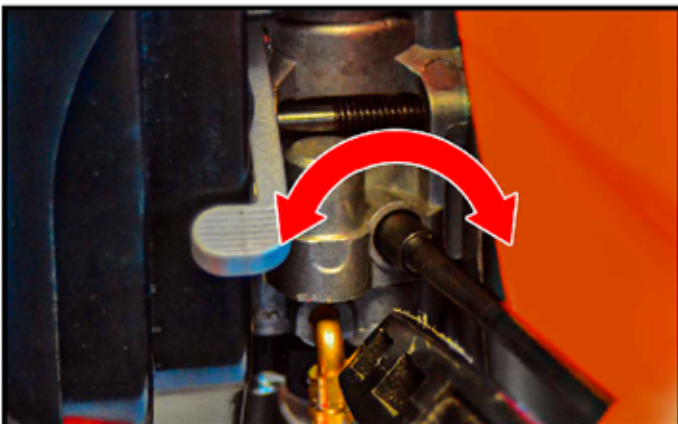

5 Gire la herramienta hacia la izquierda o hacia la derecha hasta que el motor funcione correctamente



6 Use la manija del acelerador del nebulizador para escuchar un tono alto, un zumbido constante y encontrar la velocidad correcta

Reparación rápida del tanque con fugas



1 Si el tanque de su nebulizador tiene una fuga excesiva, siga estos pasos



2 Retire la tapa de la parte superior del tanque químico del nebulizador.



3 Las fugas pueden deberse al tubo conectado al colador

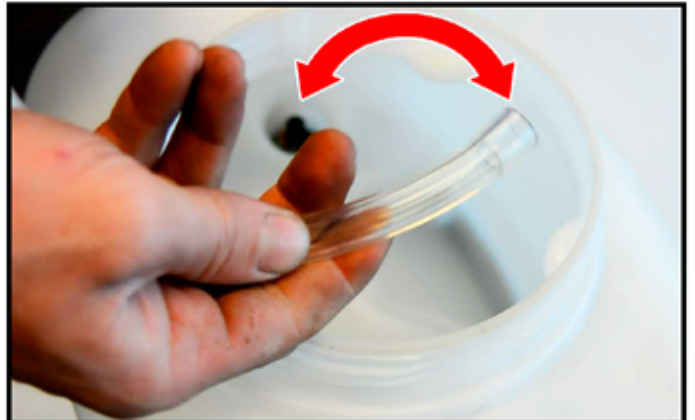

4 Si el tubo está suelto o desconectado de la base del tanque, vuelva a colocar el tubo



5 Coloque el tubo firmemente alrededor de la boquilla en la base de su tanque químico nebulizador



6 Seque bien su nebulizador y llene el tanque de químicos con agua para monitorear las fugas

Mantenimiento y solución de problemas

Mantenimiento

Antes de reparar su equipo, asegúrese de que el motor esté apagado y completamente enfriado.

Spark Plug:

PROBLEMA		CAUSA	SOLUCIÓN
Sin chispa	Bujía	1. La bujía está mojada	Secar bujía
		2. La bujía está sucia	Limpiar
		3. El aislamiento está dañado.	Reemplazar
		4. La brecha de chispa está apagada	ajustar
	Bobina de encendido	1. Envoltura de cable dañada	Arreglar o reemplazar
		2. Aislamiento de bobina mal	Reemplazar
3. El cable de la bobina roto		Reemplazar	
Chispa normal	Buena relación de compresión	1. Demasiado combustible en el cilindro	Desaguar
		2. Agua o suciedad en el combustible.	Reemplazar
	Mala relación de compresión	1. Cilindro y anillo de pistón desgastados o rotos	Reemplazar
		2. El enchufe esta flojo	Apretar
	El carburador no alimenta	1. No hay combustible en el tanque	Agregue combustible
		2. El medidor de filtro está obstruido	Limpiar
3. El tanque de combustible tiene un agujero		Limpiar	

El motor es difícil de detener:

PROBLEMA	CAUSA	SOLUCIÓN
El motor todavía funciona con el acelerador en su posición más baja.	1. El cable del acelerador tiene un corto circuito o el pistón del carburador está bloqueado	Fijar o reemplazar el cable

Mantenimiento y solución de problemas

El motor carece de potencia:

PROBLEMA	CAUSA	SOLUCIÓN
Buena relación de compresión	1. El filtro está obstruido.	Secar bujía
	2. El aire pasa a través de la conexión del carburador.	Apretar
	3. Sobrecalentamiento del motor	Parar el motor. Dejar enfriar.
	4. Agua en el combustible	Reemplazar combustible
	5. La suciedad obstruye el silenciador	Limpiar
Sobrecalentamiento del motor	1. El gas es delgado en la mezcla de combustible	Reemplazar combustible
	2. El cilindro está sucio	Limpiar
	3. El aceite es malo	Reemplace el combustible con nuevo combustible premezclado 50: 1
	4. Sin conexión con manguera	Ajuste la conexión de la manguera
El motor hace ruido o golpea	1. Combustible defectuoso Reemplace el combustible	Reemplazar combustible
	2. Suciedad en el cilindro Limpiar	Limpiar
	3. Las piezas están gastadas	Arreglar o reemplazar

El motor se detiene mientras funciona:

PROBLEMA	CAUSA	SOLUCIÓN
Buena relación de compresión	1. El cable del enchufe está suelto.	Secar bujía
	2. El pistón está roto	Arreglar o reemplazar
	3. El enchufe está sucio	Limpiar
	4. Sin combustible	Agregue combustible
El motor se detiene lentamente.	1. El carburador está sucio.	Limpiar
	2. Las mangueras al tanque están obstruidas	Limpiar
	3. Agua en el combustible	Reemplazar combustible

Mantenimiento y solución de problemas

Dificultades para desempolvar:

PROBLEMA	CAUSA	SOLUCIÓN
No hay descarga de polvo o la descarga es intermitente	1. La puerta de polvo no se puede abrir.	Ajustar
	2. La tapa del tanque no está apretada	Apretar
	3. El polvo o gránulo está sucio.	Limpiar
	4. El polvo o gránulo está sucio.	Bultos en los senos o reemplazar
	5. Los gránulos son demasiado grandes	Use gránulos más pequeños
La compuerta antipolvo no funciona correctamente	1. El carburador está sucio.	Limpiar
	2. Las mangueras al tanque están obstruidas	Limpiar
	1. La placa de sujeción del fondo del tanque químico está suelta	Reemplazar
	2. La junta de sellado de la tapa antipolvo está dañada.	Reemplazar
	3. La junta tórica del codo está dañada.	Reemplazar
La tasa de descarga está fuera de control.	1. La palanca de control de polvo no funciona correctamente	Ajuste el cable o arregle el carburador.

Dificultades pulverizando:

PROBLEMA	CAUSA	SOLUCIÓN
Buena relación de compresión	1. El interruptor de la boquilla o la válvula de control están obstruidos	Limpiar
	2. El tubo de plomo líquido está obstruido	Limpiar
	3. Sin presión o baja presión	Apriete la tapa del tanque y atornille las dos tuercas de mariposa.
Fuga de mezcla de pulverización	1. La tapa está colocada incorrectamente.	Apretar correctamente
	2. Las uniones de hilo están flojas	Apretar correctamente



MOTOPULVERIZADORA
van Beek 3vB-14T TURBO BOOST

MANUAL DE
REPUESTOS



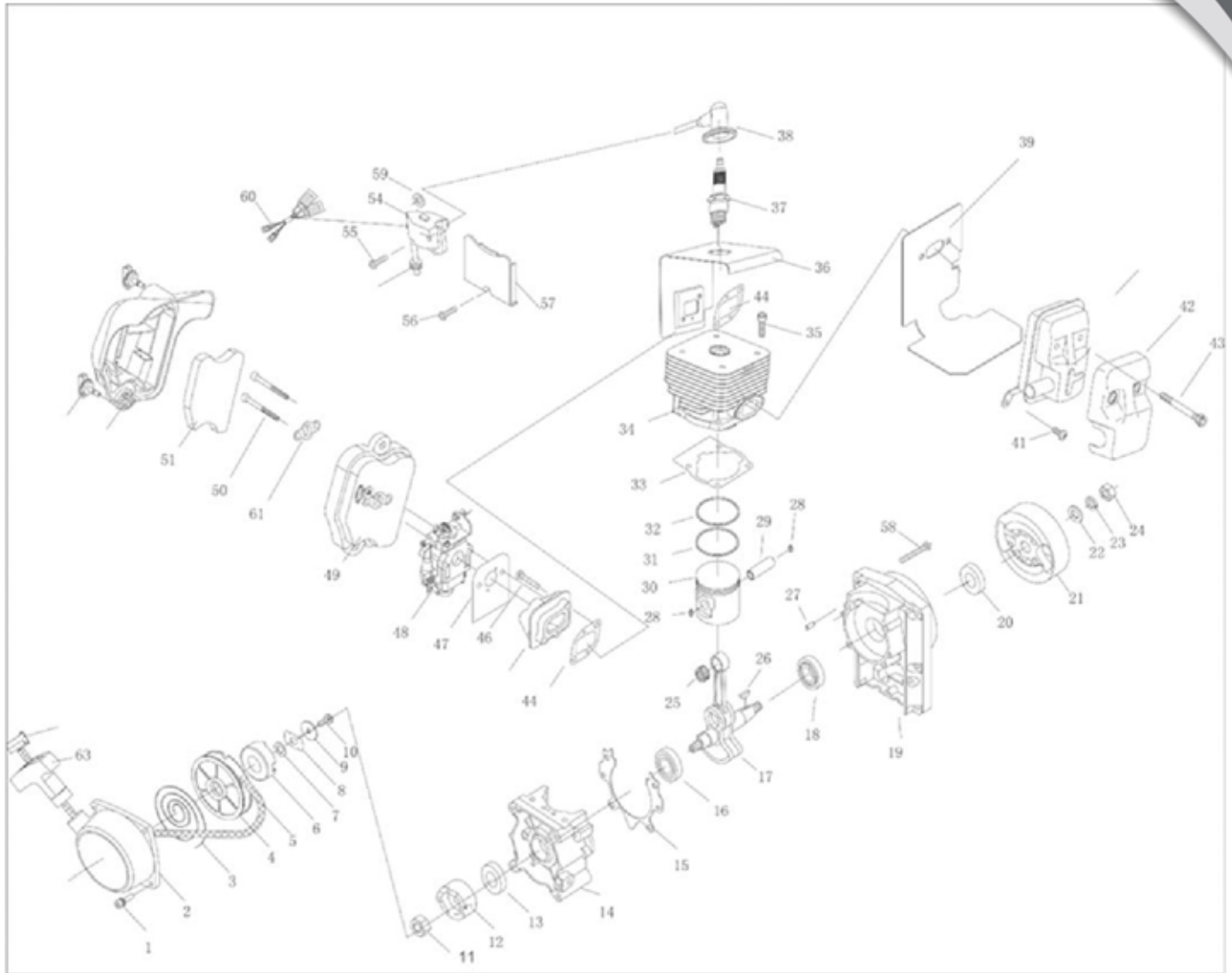

NO.	Parte NO.	Nombre	cantidad.
1	GB/T70.1+GB93+GB97	Tornillo M5X18	4
2	1E40FP-3Z.4-1	Case	1
3	1E40FP-3Z.4-7	Resorte	1
4	1E40FP-3Z.4-6	Polea	1
5	1E40FP-3Z.4-9	Cuerda	1
6	1E40FP-3Z.4-8	Rueda estrella	1
7	GB860 8	Lavadora	1
8	1E40FP-3Z.4-5	Parte de la guía	1
9	1E40FP-3Z.4-4	Lavadora	1
10	GB67 M5X12	Tornillo	1
11	GB6170 M8	Tuerca	1
12	vB F-960.1-2	Trinquete	1
13	1E36F.2	Sello de aceite	2
14	1E40F-E.6-2	Cigüeñal	1
15	1E40F-5.8-4	Empaquetadura	1

NO.	Parte NO.º	Nombre	cantidad
16	GB/T276	Cojinete 6202/P6	1
17	EB-500-E.1.2.1	Cigüeñal	1
18	GB/T276	Cojinete 6202/P6	1
19	EB-500-E.1.3-1	Cigüeñal	1
20	1E40F-5.9	Sello de aceite	1
21	1E46FP.1.1	Volante	1
22	GB96 8	Lavadora	1
23	GB96 8	Lavadora	1
24	GB6170 M8	Tuerca	1
25	1E44F-2A.2-3	Cojinete	1
26	GB1099	Llave 3X5X13	1
27	GB119	4H8 10	1
28	P40.6-4	Aro	2
29	1E44F-2A.2-2	Pasador del pistón	1
30	1E44F-E.3-1	Piston	1
31	1E44F-2A.2-4	Anillo de pistón	1
32	1E44F-2A.2-4	Anillo de pistón	1
33	1E40F-5-6	Empaquetadura	1
34	EB-500-E.1-2	Cilindro	1
35	GB70.1	Tornillo M5X20	4
36	EB-500-E.1-1	Manto	1
37	RCJ6Y	Bujía	1
38	1E46FP.1-1	Ensamblaje de tapa de enchufe.	1
39	EB-500-E.1-4	Empaquetadura	1
40	EB-500-E.1.1	silenciador	1
41	GB/T70.1+GB93+GB97	Tornillo M5X12	1
42	EB-500-E.1-3	Escudo de silenciador	2
43	GB70.1+GB97	Tornillo M6•60-12.9	2
44	1E40F-5-2	Empaquetadura	2
45	1E44F-E-PBJ.7	Tubo de admisión	1
46	GB70.1 5*25	Tornillo	2
47	EB-500-E.1-5	Empaquetadura	1
48	1E48FP-E.4	Carburador	1
49	EB-500-E.1.6.1	Cubierta interior más limpia	1
50	GB70.1+GB93+GB97	Tornillo M5•55	2
51	EB-500-E.1.6-3	Filtro de red	1
52	EB-500-E.1.6-1	Cubierta exterior más limpia	1
53	1E34F.1.2A	Tornillo	2
54	1E46FP.1.1	Bobina de encendido Comp.	1
55	GB/T9074.13 M4X20	Tornillo	2
56	GB/T9074.4 M5X20	Tornillo	1
57	1E46FP-2	Proteger	1
58	GB70.1	Tornillo M5•30	4

NO.	Parte NO.	Nombre	cantidad
59	P40-5	Lavadora	2
60	EB-500-E.1-6	Estacionamiento	1
61	P40.1-3	Deflector	1
62	1E40FP-3Z.4-10	Cubrir	1
63	1E40FP-3Z.4-3	Cubrir	1
64	1E40FP-3Z.4-2	manipular	1

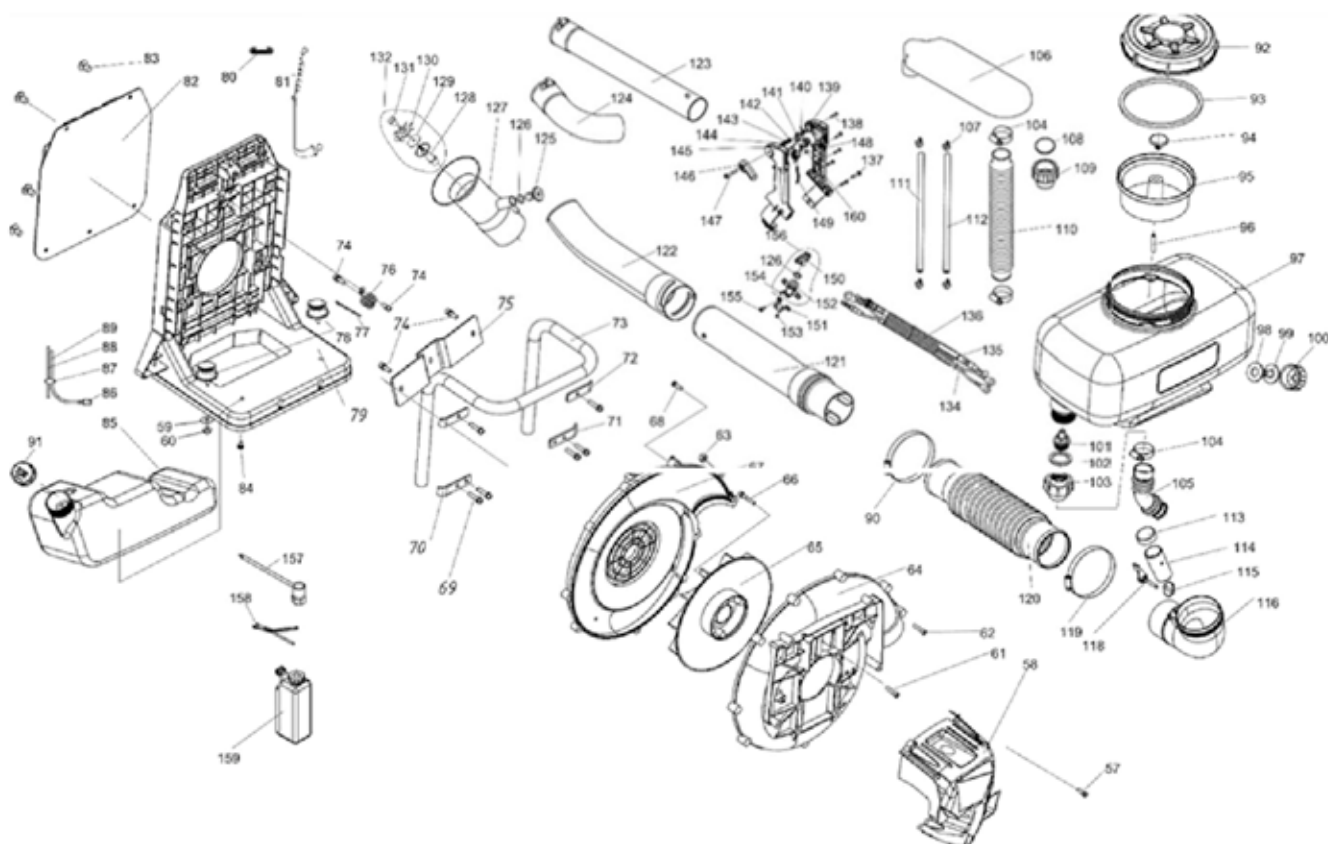

NO.	Parte NO.	Nombre	Qty.
57	vBF-20.9-2	Tornillo	4
58	EB-500-E-4	Proteccion	1
59	GB/T96	Lavadora 6	2
60	GB/T6177	tuerca M6	2
61	GB70+GB93+GB97	Tornillo M6•30	6
62	GB/T818	Tornillo M5•70	2
63	GB/T6170	M5 tuerca	2
64	EB-500-E.2-1	Caso de voluta	1
65	EB-500-E.2.3	Impulso	1
66	GB70+GB93+GB97	Tornillo	4
67	EB-500-E.2-2	Caso de voluta	1
68	XSS46-2.2-5	Tornillo	10
69	GB70+GB93+GB97	Tornillo	6
72	vB F-14-9	Tablero	2
73	vB F-14B-4A	Soporte	1

NO.	Parte NO.	Nombre	Cantidad
74	GB70+GB93+GB97	Tornillo	4
75	vB F-14B-3	Tablero	3
76	vB F-14-12	Resorte	1
77	250*4.5	Línea	1
78	vB-30.17	Pilar de goma	2
79	vB F-14-7	Cuadro	1
80	EB-650-10	Axis	2
81	EB-650.10	Gallus	2
82	vB F-14.7	Mate	1
83	vB F-2.6B-2	Clip de plástico	5
84	GB/T9074.4 M6•12	Tornillo	2
85	EB-500-E.4-1	Tanque de gasolina	1
86	1E34F.9.2-3D	Filtro	1
87	EB-415.4.2-2	Tapón	1
88	EB-415.4.2-4	Tubo(180Mm)	1
89	CG420.1.3.2-2	Tubo (350Mm)	1
90	GB/T 8870	Hoop059-082	1
91	1E32FL.6.2	Tapa	1
92	vB F-8.1-2A	Tapa	1
93	vB F-8.1-1	arandela de sellado	1
94	vB F-14.3-1	Válvula de aire	1
95	vB F-14.3-3	Filtro	1
96	GB/T13527.1 8 1.5•500	Tubo	1
97	vB F-14B.2-1	Tanque químico	1
98	vB F-3A.1-2	arandela de sellado	1
99	vB F-3A.1-1	Tubo de enlace	1
100	vB F-3A.1-3	Tapa del conector	1
101	vB -16.4-2	conector	1
102	vB -16.4-3	arandela de sellado	1
103	vB -16.4-1	Tapa del conector	1
104	JB/T8870	Hoop025-040	3
105	vB F-14B-5	conector	1
106	vB F-16.2-1	Tubo	1
107	vB F-3-3	Tubo	4
108	vB F-950.2.1-2	Curva	1
109	vB F-950.2.1-1	Tapa del conector	1
110	vB F-16.2-3	Tubo	1
111	GB/T13527.1 10•1.5 830	Tubo	1
112	GB/T13527.1 10 1.5•880	Tubo	1
113	vB F-16.3-1	Enchufe	1
114	vB F-950.1.1-1	Tubo	1
115	vB F-16.3.1-3	Tablero	1
116	vB F-14B.1.1-1	Codo	1

NO.	Paret NO.	Nombre	cantidad
118	vB F-16.3.1-2A	Interruptor	1
119	GB/T 8870	Hoop078-0102	1
120	vB F-3.19-4	Tubo	1
121	vB F-2.6.4.1	Conector	1
122	vB F-2.6.4-2	Tubo	1
123	vB F-2.6.4-4	Tubo	1
124	vB F-2.6.4-3	Tubo	1
125	vB F-3.19.3-3	Válvula	1
126	GB1235 16*2.4	Arandela de sellado	1
127	vB F-2.6.4.3-1	Boquilla	1
128	vB F-2.6.4.3.1.1	Boquilla	1
129	vB F-2.6.4.3.1-1	Lavadora	1
130	vB F-2.6.4.3.1-3	Impulsor de rotación	1
131	vB F-2.6.4.3.1-2	Asiento	1
132	vB F-2.6.4.3.1	Boquilla	1
133			
134	vB -15A-3	Línea	1
135	vB F-14B.3.1.1	Línea	1
136	CG328.1.1-4	Tubo	1
137	GB/T 845	St5.5*25 Tornillo	1
138	GB/T 845	St4.2*19 Tornillo	5
139	vB F-14.5.1-2	Mango	1
140	vB F-14.5.1-7	Resorte	1
141	vB F-14.5.1-3	Mango	1
142	GB/T6172.2	M6 Tuerca	1
143	vB F-14.5.1-8	Lavadora	1
144	GB/T955	Lavadora	1
145	vB F-14.5.1-1	Handgrip	1
146	vB F-14.5.1-10	Handgrip	1
147	vB F-14.5.1-9	Tornillo	1
148	vB F-14.5.1-5	Interruptor	1
149	vB F-14.5.1-4	Pieza	1
150	vB F-3.19.1-1	Centro	1
151	vB F-14.5.1.2-1	Asiento	1
152	vB F-3.19.1-2	Armazón	1
153	GB/T 845	St4.2X8 Tornillo	1
154	GB/T828	M3X5X2.5 Tornillo	2
155	GB/T845	St4.8*13 Tornillo	1
156	vB F-3.19.1	Cock Assem(No Board)	1
157	vB Z-4.15.1	Llave inglesa	1
158	vB F-3.25.4	Cadena	1
159	ZB4-10.1	Aceite de botella	1
160	vB F-14.5.1-6	Estuche	1



Backpack Fogger van Beek 3vB-14T TURBO BOOST

USER MANUAL



Congratulations on purchasing your

**Backpack Fogger
van Beek TURBO**



LET'S START

Table of contents

Table of Contents	3
Package Contents	4
Assembly Guides	5
<i>Fogger Liquid Assembly</i>	6
<i>Tree Top Liquid Assembly</i>	8
Safety Precautions and Warnings	10
Fueling	11
Start Up Guide	12
Stopping Your Engine	13
Adding Chemicals	14
Adjusting Options	14
Technical Specifications	15
Features and Use	15
Troubleshooting	16
<i>Carburetor Adjustment Guide</i>	16
<i>Leaking Tank Quick Fix</i>	17
<i>More Troubleshooting</i>	18
Spare Parts Manual	22
Warranty Statement	28

Package Contents



OPCIONAL



OPCIONAL



van Beek 3vB-14T BACKPACK FOOGER

- A. RIBBED TUBE
- B. CONNECTING PIPE
- C. BLOWER PIPE
- D. FAN NOZZLE
- OPTIONAL 1: EXTENSION PIPE
- OPTIONAL 2: ELBOW TUBE

ADDITIONAL PARTS

- 2 CLEAR TUBES
- 2 HOSE CLAMPS
- 1 DUSTER TANK
- 1 DUSTER TUBE
- 1 SCREED
- 1 GROUNDING CHAIN

Standard Assembly PT 1



1 Remove all parts from your mistblower box, including the tool kit bag



2 Fasten the ribbed tube (A) to the blower elbow



3 Secure the ribbed tube with a hose clamp to the blower elbow



4 Attach the connecting pipe (B) and secure it to the ribbed tube with a hose clamp



5 Attach the blower pipe (C) by meeting the raised dimple to the slot guide



6 Twist to lock in place

Standard Assembly PT 2

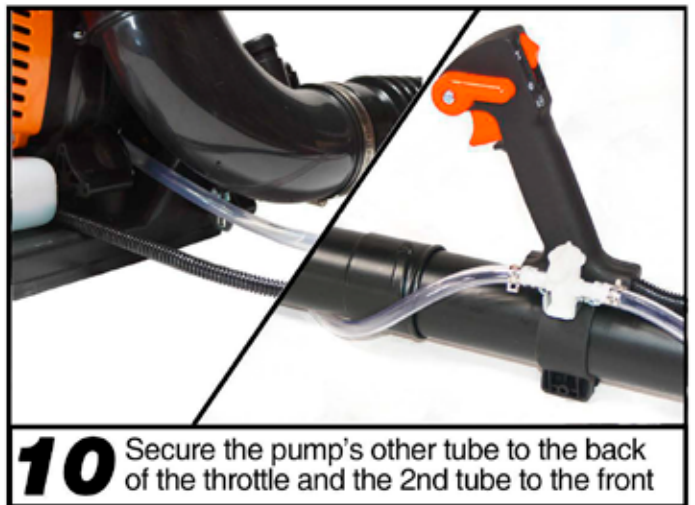
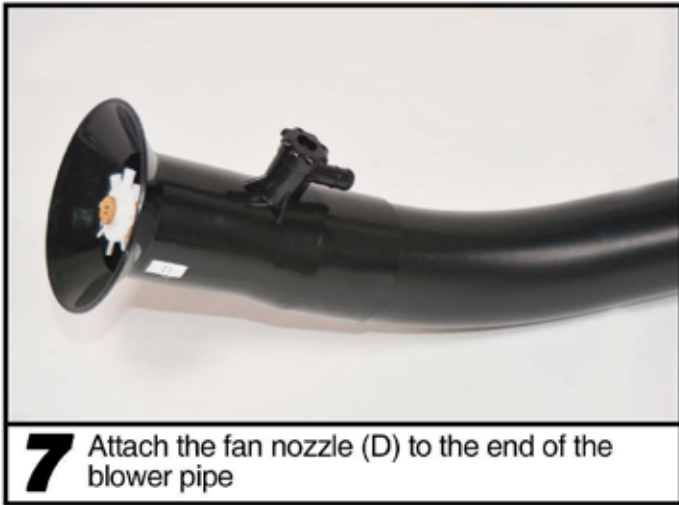

Tree Top Assembly Pt 1



1 Remove all parts from your mistblower box, including the tool kit bag



2 Fasten the ribbed tube (A) to the blower elbow



3 Secure the ribbed tube with a hose clamp to the blower elbow



4 Attach the connecting pipe (B) and secure it to the ribbed tube with a hose clamp



5 Attach the blower pipe (C) by meeting the raised dimple to the slot guide



6 Twist to lock in place

Tree Top Assembly Pt 2



7 Attach the elbow tube to the blower pipe (C) and secure the fan nozzle (D) to its end



8 Slip the throttle over the connecting pipe (B) and tighten with the tool kit's screw



9 Attach the top tube from the turbo pump to the base of the chemical tank

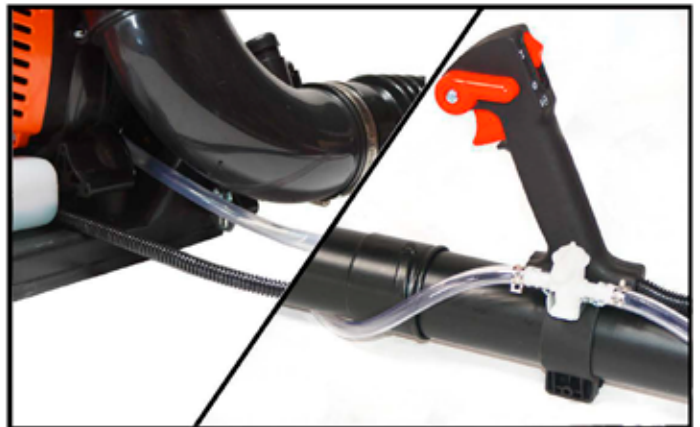

10 Secure the pump's other tube to the back of the throttle and the 2nd tube to the front



11 Wrap the 2nd tube around the elbow tube and attach its end to the fan nozzle (D)



12 To begin fogging, add 50:1 Pre Mix Fuel (fuel not included)

SAFETY PRECAUTIONS AND WARNINGS

Operator Precautions

1. This product emits carbon monoxide, an invisible and odorless toxin. Do not run this product indoors at any time.
2. Always turn engine off before adding fuel to the tank.
3. To avoid electrocution, do not touch the cap of the spark plug or wiring while the engine is on.
4. Do not touch the surface of the muffler and the cylinder while the engine is running. It is extremely hot.

Equipment Warnings

1. The TMD14's 2 stroke engine runs on 50:1 fuel mix. Use 91 octane gas and two-cycle engine oil. Note: 50:1 pre-mix fuel is ideal for this product as it contains fuel stabilizers to ensure longevity of the equipment.
2. After starting the engine, keep the throttle at a low speed for several minutes before running at full throttle.
3. Gasoline is an extremely flammable fuel. When operating, keep away from any flames. Do not smoke while operating.
4. Do not spray in the direction of others.

Chemical Handling

1. Wear ear protection.
2. Wear eye protection.
3. Use a mask to protect mouth and face against dust and pesticides.
4. Wear closed-toed protective shoes.
5. Wear gloves to avoid contact with pesticides.
6. Wear proper clothing to protect arms and legs to avoid contact with pesticides.
7. After spraying, wash hands and clothing immediately.

FUELING

- This engine is certified to operate on unleaded gasoline and two-stroke engine oil at a mix ratio of 50:1.
- This engine requires a mixture of high-quality gasoline and 2-stroke air cooled engine oil.
- Use mid-grade unleaded gasoline with a minimum octane rating of 91 and no more than 10% ethanol content.
- Keep the fuel tank far away from flames or sparks. Do not smoke near fuel.
- When adding pre-mixed fuel to the engine, use a funnel to avoid spillage.
- When the machine is running, do not add more to the fuel tank.
- Open the fuel cap carefully to allow any pressure build-up in the tank to release slowly and avoid fuel spillage.
- At the end of a season, drain all fuel from gas tank and use fuel stabilizer to ensure a clear carburetor for your next season.

ATTENTION: USE ONLY 50:1 PREMIX 2 STROKE ENGINE FUEL OR A 50:1 COMBINATION OF 93 OCTANE GASOLINE AND 2 STROKE ENGINE OIL

WARNING

WHEN STARTING THE ENGINE, USE WATER-BASED OR WATERBORNE COMPOUNDS ONLY.

RUNNING THIS MACHINE WITHOUT WATER-BASED COMPOUNDS IN THE TANK WILL BREAK THE PUMP AND VOID THE WARRANTY

READ OWNER'S MANUAL BEFORE OPERATION

Start Up Guide



1 Fill the fuel tank with a 2 Stroke 50:1 Pre Mix Fuel for the optimal engine efficiency



2 Move the throttle handle to the On Position labeled "I"

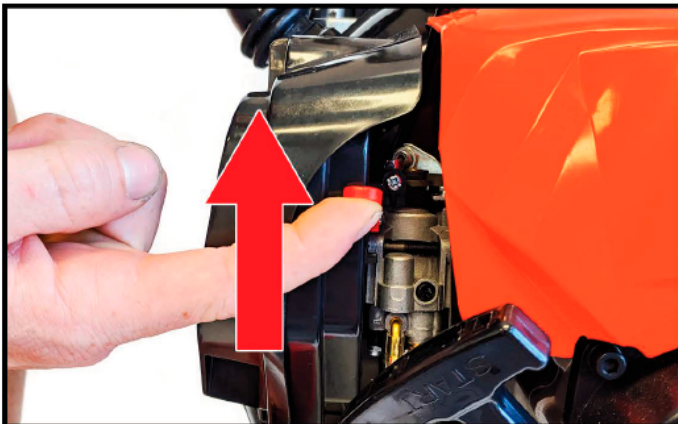

3 Move the choke to the up position

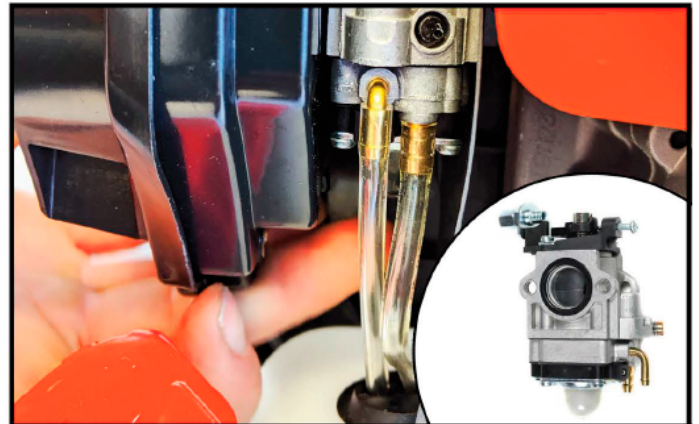

4 To prime the engine, press the carburetor bulb 4-5 times or until fuel runs through the lines

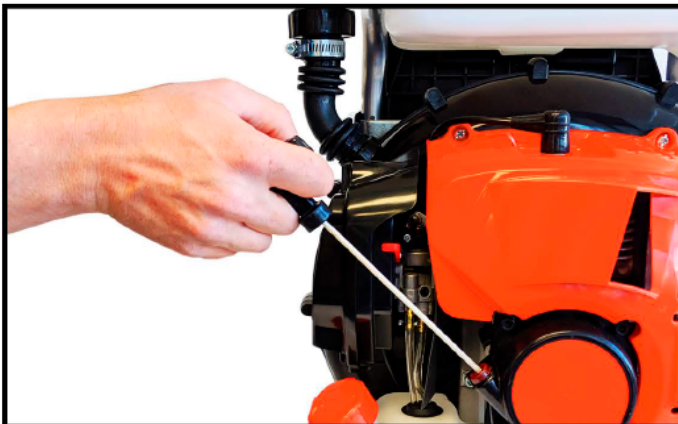

5 Pull the recoil starter cord until the engine turns over and starts

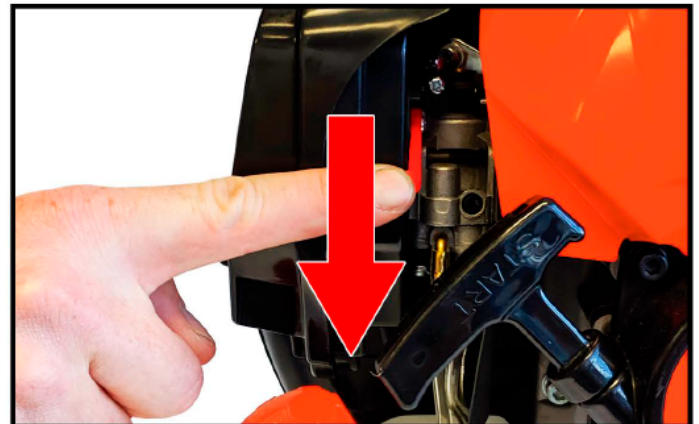

6 Once the engine fires up, slowly move the choke to the down position

STOPPING YOUR ENGINE

1. Move the water valve to the closed position to stop the flow of liquid pesticide. Figure 1.
2. Move the throttle lever to the down position (O) to stop the engine. Figure 2.
3. Move the choke to the closed position. Figure 3.

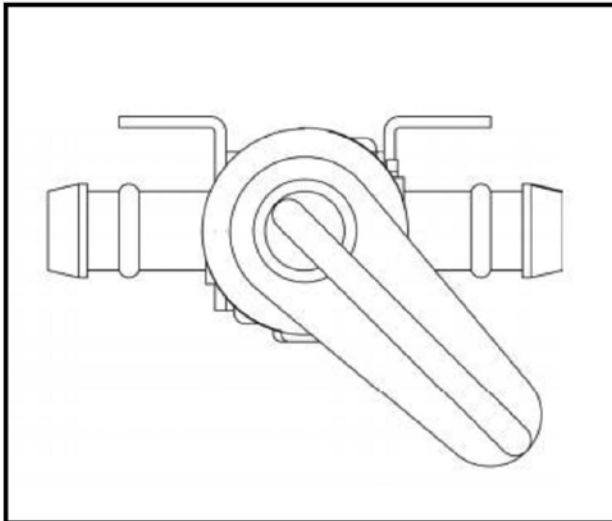

FIGURE 1

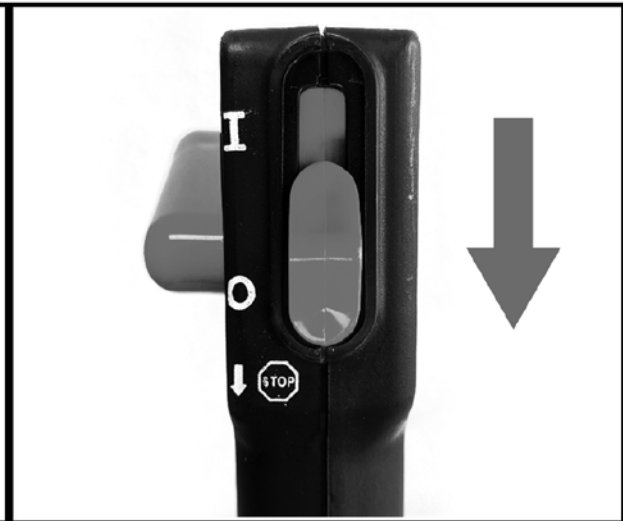

FIGURE 2

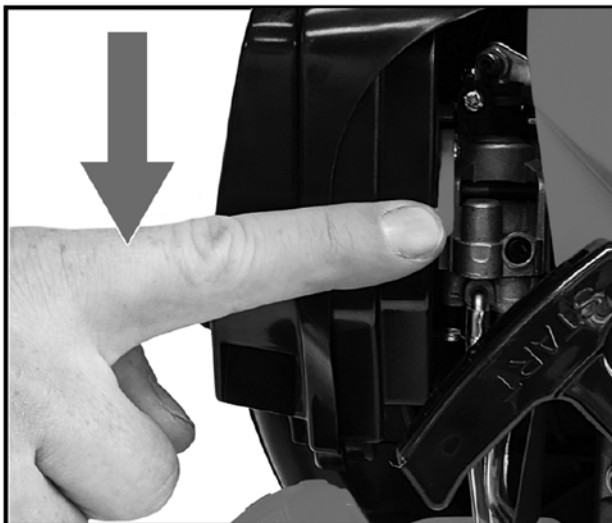

FIGURE 3

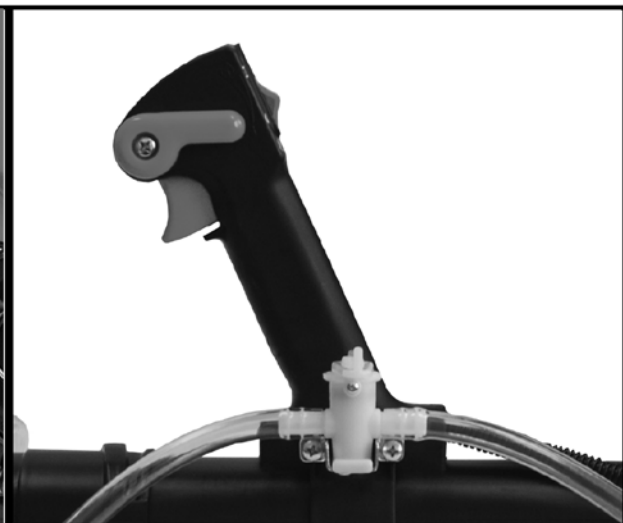

FIGURE 4

ADDING CHEMICALS AND ADJUSTING OPTIONS

Adding Chemicals

Warning- Some chemicals sprayed with the mist blower can contain toxic substances which can lead to serious side effects and injury.

1. Avoid direct contact with chemicals and always follow the instructions of the chemical manufacturer. Always wear the proper clothing and chemical protection
2. It's important to dilute your chemicals according to the chemical manufacturer's specifications. Never spray undiluted chemicals.
3. Dilute and prepare your chemicals prior to turning on your mist blower.
4. Prepare your chemical and pour into the mist blower water tank outdoors or in a well ventilated area.
5. After spraying, do not keep the spray solution in the tank. Properly dispose of the excess spray solution and rinse your machine after each use.

Adjusting Options

1. **Water Flow-** To adjust water flow use the water valve to increase the flow of water from the tank. See Figure 1.
2. **Water Speed-** To adjust the speed of water use the accelerator to increase the engine's speed. See Figure 4.
3. **Dust Flow-** To adjust dust flow move lever to the left. Move the lever to the right to reduce dust flow. See Figure 5.
4. **Spray Pattern-** To adjust spray pattern use the knob on the horn nozzle. 1 being the least amount of flow and 4 being the most. See Figure 6.

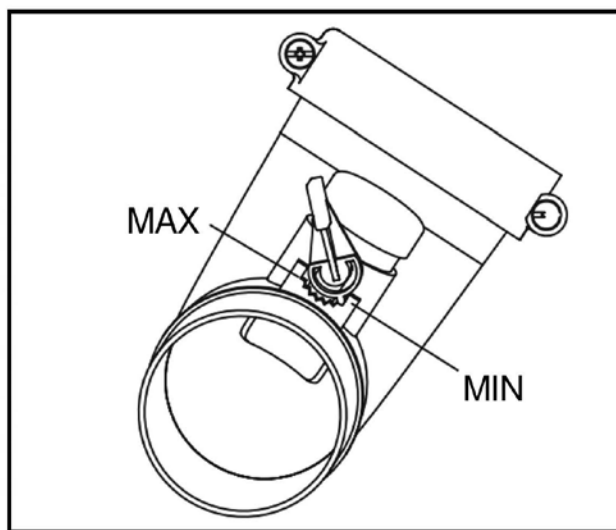

FIGURE 5

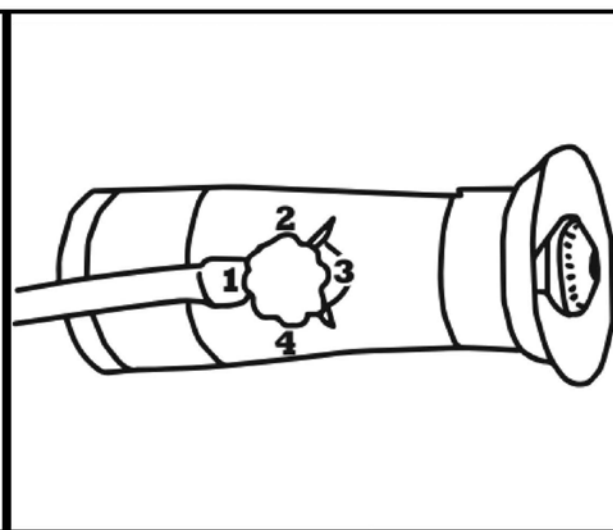

FIGURE 6

TECHNICAL SPECIFICATIONS

Dimensions	18" x 12" x 26"
Net Weight	24 lbs
Tank Capacity	3.7 Gallons (14 Liters)
Engine Size	63cc
Engine Speed	6500RPM
Engine Power	1.5kW
Blower Speed	475 CFM (up to 200mph)
Fuel Type	Recommended 40:1 Premix Fuel OR 2 Stroke Oil with 91 Octane Gasoline
Spraying Options	Dust or Liquid
Vertical Reach	25 ft Max
Horizontal Reach	Up to 40ft

FEATURES & USE

Features	Target Pests	For Use Around
<ul style="list-style-type: none"> • Spray 1 acre in less than 30 minutes • 4X faster than Pump Sprayers • Vertical Range of 25 ft • Horizontal Range up to 40ft 	<ul style="list-style-type: none"> • Mosquitoes & Ticks • Ants & Cockroaches • Caterpillars and Worms • Fleas • Biting Flies & Horse Flies • Scorpions & Wasps • Spider Mites • Thrips • Stink Bugs & Beetles • And More 	<ul style="list-style-type: none"> • Commercial & Residential • Farms & Barns • Dairies & Kennels • Livestock • Ornamental Plants • Orchards • Vegetable Gardens • Parks & Recreation Areas • Golf Courses • And More

Carburetor Adjustment Guide



1 If your fogger engine is bogging down or only runs with the choke open, follow these steps



2 Identify the engine's carburetor in between the engine cover and air filter



3 Tune up your carburetor by adjusting the keyhole (pictured above)



4 Use a carburetor adjustment tool* to tune the engine's carburetor *while the engine is running*

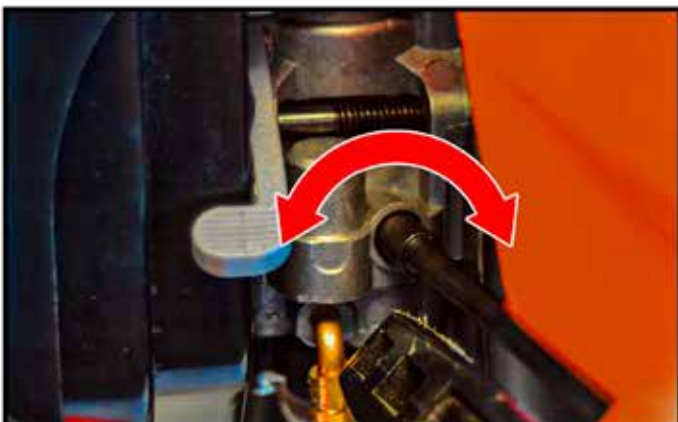

5 Turn the tool to the left or right until the engine is running correctly**



6 Use the fogger's throttle handle to listen for a high pitch, steady hum & find the right speed

Leaking Tank Quick Fix



1 If your fogger tank is leaking excessively, follow these steps



2 Remove the cap from the top of the fogger's chemical tank



3 Leaking may be caused by the tubing attached to the strainer

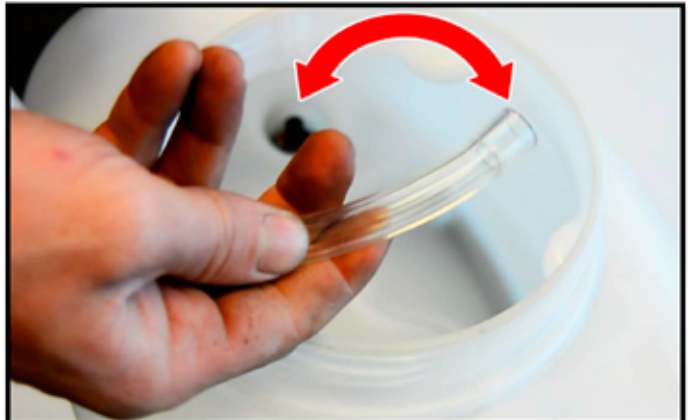

4 If the tubing is loose or disconnected from the base of the tank, reattach the tube



5 Fit the tube tightly around the nozzle at the base of your fogger's chemical tank



6 Dry off your fogger thoroughly and fill the chemical tank with water to monitor leakage*

MAINTENANCE & TROUBLESHOOTING

Maintenance

Before fixing your equipment, make sure the engine is turned off and completely cooled down.

Spark Plug:

PROBLEM		CAUSE	SOLUTION
No Spark	Spark Plug	1. Spark plug is wet	Dry Spark Plug
		2. Spark plug is dirty	Clean
		3. The insulation is damaged	Replace
		4. Spark gap is off	Adjust
	Ignition coil	1. Wrap of wire damaged	Fix or Replace
		2. Insulation of coil bad	Replace
3. The wire of coil broken		Replace	
Normal Spark	Good Compression ratio	1. Too much fuel in the cylinder	Drain
		2. Water or dirt in the fuel	Replace
	Poor Compression Ratio	1. Cylinder and piston ring worn or torn	Replace
		2. The plug is loose	Tighten
	Carburetor Not Fueling	1. No fuel in the tank	Add Fuel
		2. Filter gauge is clogged	Clean
		3. Fuel tank has a hole	Clean

Engine Lacks Power:

PROBLEM	CAUSE	SOLUTION
Good Compression Ratio	1. Filter is clogged	Clean
	2. Air passes through the connection of carburetor	Tighten
	3. Engine overheats	Stop Engine. Let Cool.
	4. Water in the fuel	Replace Fuel
	5. Dirt clogs the muffler	Clean
Engine Overheats	1. Gas is thin in fuel mix	Replace Fuel
	2. Cylinder is dirty	Clean
	3. Oil is bad	Replace Fuel with New 50:1 Pre Mix Fuel
	4. No connection with hose	Adjust hose connection
Engine is noisy or knocking	1. Fuel bad Replace fuel	Replace Fuel
	2. Dirt in cylinder	Clean
	3. Parts are worn	Fix or Replace

MAINTENANCE & TROUBLESHOOTING

Engine stops while running:

PROBLEM	CAUSE	SOLUTION
Engine stops suddenly	1. Wire of plug is loose	Replace
	2. Piston is broken	Fix or Replace
	3. Plug is dirty	Clean
	4. Fuel is empty	Add Fuel
The engine stops slowly	1. Carburetor is dirty	Clean
	2. Hoses to tank are clogged	Clean
	3. Water in the fuel	Replace Fuel

Engine is difficult to stop:

PROBLEM	CAUSE	SOLUTION
The engine still runs with the throttle at its lowest position	1. The throttle cord has short circuited or carburetor piston is blocked.	Fix or Replace Cord

Difficulties dusting:

PROBLEM	CAUSE	SOLUTION
No dust discharge or discharge is intermittent	1. The dust gate cannot be opened	Adjust
	2. The tank lid not is tight	Tighten
	3. The dust or granule is dirty	Clean
	4. The dust/granule has lumps	Break lumps or replace
	5. The granules are too big	Use smaller granule
The dust gate does not work properly	1. Carburetor is dirty	Clean
	2. Hoses to tank are clogged	Clean
Dust leakage	1. The clamp plate of the chemical tank bottom is loose	Tighten
	2. The sealing gasket of the dusting lid is damaged	Replace
	3. The O ring of the elbow is damaged	Replace
The discharge rate is out of control	1. The dust control lever is not work properly	Adjust the cord or fix the carburetor.

MAINTENANCE & TROUBLESHOOTING

Difficulties fogging:

PROBLEM	CAUSE	SOLUTION
No mist or mist is irregular	1. Nozzle switch or control valve is clogged	Clean
	2. Liquid lead pipe is clogged	Clean
	3. No pressure or low pressure	Tighten the tank lid and screw down the two wing nuts.
Spray mixture leak	1. The lid is placed incorrectly	Tighten correctly
	2. Thread joints are loose	Tighten correctly



Backpack Fogger van Beek 3vB-14T TURBO BOOST

SPARE PARTS REPUESTOS



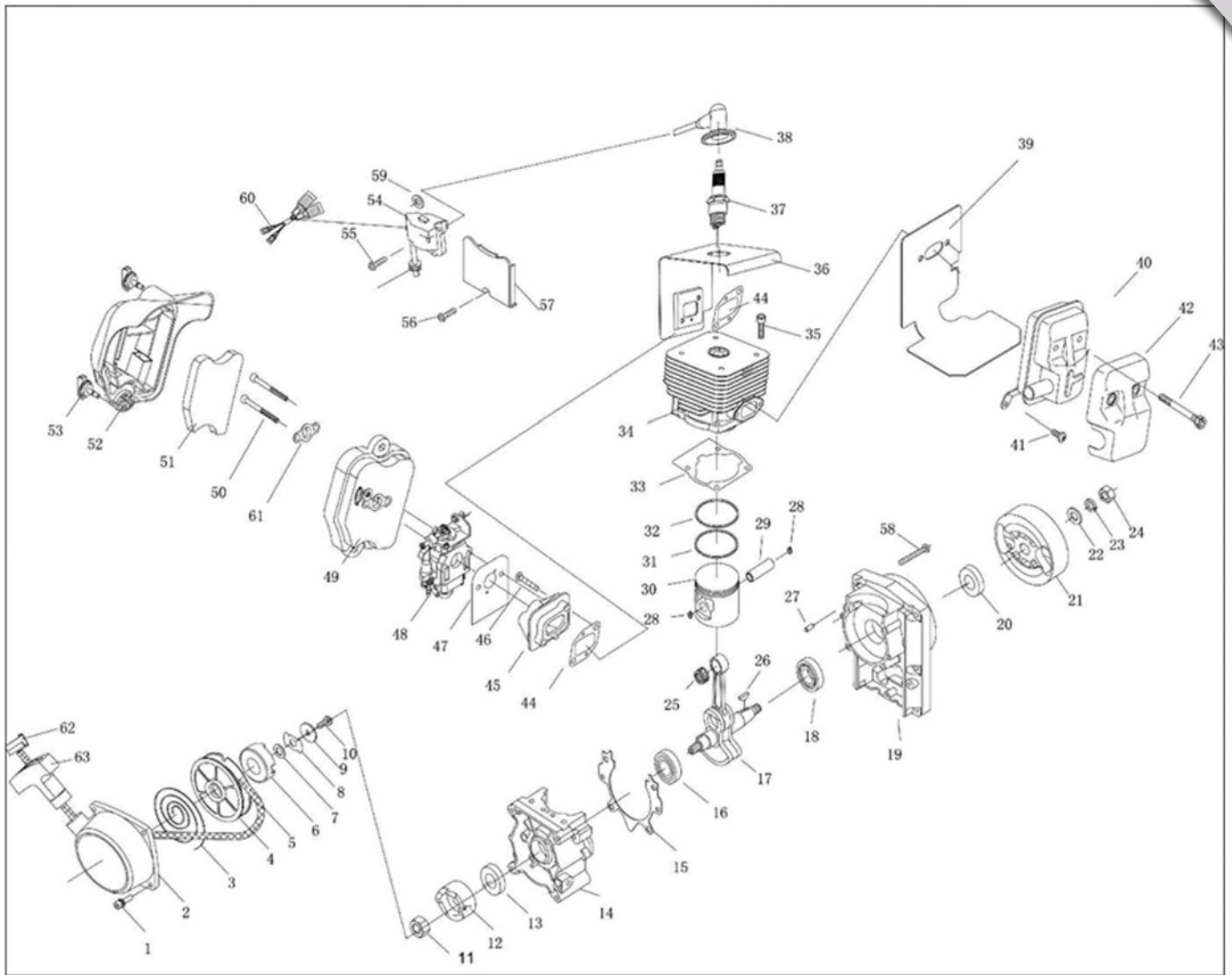

NO.	Part NO.	Part Name	Qty.
1	GB/T70.1+GB93+GB97	Screw M5X18	4
2	1E40FP-3Z.4-1	Case	1
3	1E40FP-3Z.4-7	Spring	1
4	1E40FP-3Z.4-6	Pulley	1
5	1E40FP-3Z.4-9	Rope	1
6	1E40FP-3Z.4-8	Start Wheel	1
7	GB860 8	Washer	1
8	1E40FP-3Z.4-5	Guide Slice	1
9	1E40FP-3Z.4-4	Washer	1
10	GB67 M5X12	Screw	1
11	GB6170 M8	Nut	1
12	vB F-960.1-2	Ratchet	1
13	1E36F.2	Oil-Seal	2
14	1E40F-E.6-2	Crank Case	1
15	1E40F-5.8-4	Gasket	1

NO.	Part NO.	Part Name	Qty.
16	GB/T276	Bearing 6202/P6	1
17	EB-500-E.1.2.1	Crank Shaft	1
18	GB/T276	Bearing 6202/P6	1
19	EB-500-E.1.3-1	Crank Case	1
20	1E40F-5.9	Oil-Seal	1
21	1E46FP.1.1	Fly Wheel	1
22	GB96 8	Washer	1
23	GB96 8	Washer	1
24	GB6170 M8	Nut	1
25	1E44F-2A.2-3	Bearing	1
26	GB1099	Key 3X5X13	1
27	GB119	4H8×10	1
28	P40.6-4	Ring	2
29	1E44F-2A.2-2	Piston Pin	1
30	1E44F-E.3-1	Piston	1
31	1E44F-2A.2-4	Piston Ring	1
32	1E44F-2A.2-4	Piston Ring	1
33	1E40F-5-6	Gasket	1
34	EB-500-E.1-2	Cylinder	1
35	GB70.1	Screw M5X20	4
36	EB-500-E.1-1	Mantle	1
37	RCJ6Y	Spark Plug	1
38	1E46FP.1-1	Plug Cap Ass.	1
39	EB-500-E.1-4	Gasket	1
40	EB-500-E.1.1	Muffler	1
41	GB/T70.1+GB93+GB97	Screw M5×12	1
42	EB-500-E.1-3	Muffler Shield	2
43	GB70.1+GB97	Screw M6×60-12.9	2
44	1E40F-5-2	Gasket	2
45	1E44F-E-PBJ.7	Admitting Pipe	1
46	GB70.1 5*25	Screw	2
47	EB-500-E.1-5	Gasket	1
48	1E48FP-E.4	Carburetor	1
49	EB-500-E.1.6.1	Cleaner Inside Cover	1
50	GB70.1+GB93+GB97	Screw M5×55	2
51	EB-500-E.1.6-3	Filter Net	1
52	EB-500-E.1.6-1	Cleaner Outside Cover	1
53	1E34F.1.2A	Screw	2
54	1E46FP.1.1	Ignition Coil Comp.	1
55	GB/T9074.13 M4X20	Bolt	2
56	GB/T9074.4 M5X20	Bolt	1
57	1E46FP-2	Shield	1
58	GB70.1	Screw M5×30	4

NO.	Part NO.	Part Name	Qty.
59	P40-5	Washer	2
60	EB-500-E.1-6	Parking	1
61	P40.1-3	Baffle	1
62	1E40FP-3Z.4-10	Cover	1
63	1E40FP-3Z.4-3	Cover	1
64	1E40FP-3Z.4-2	Handle	1

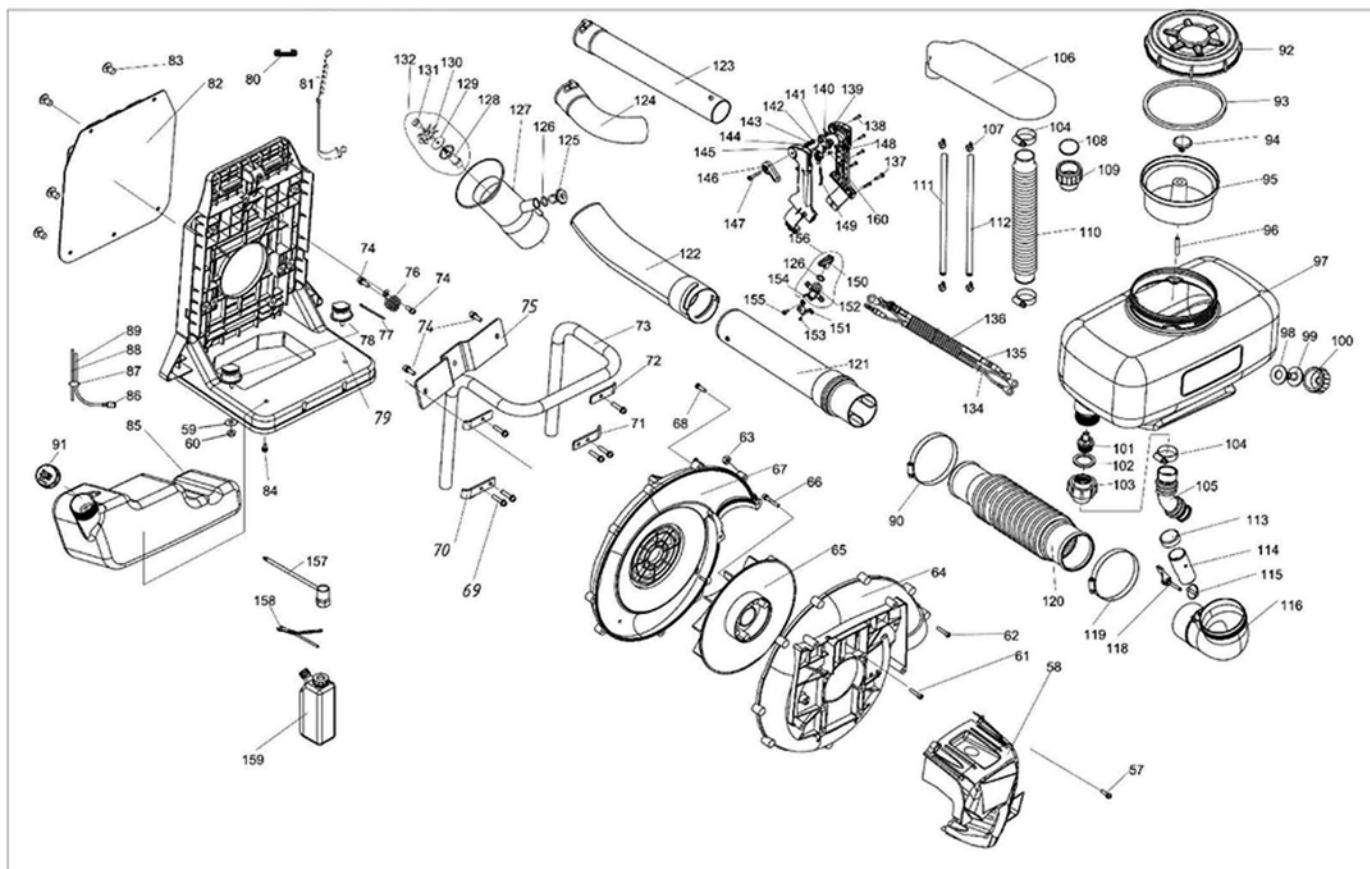

NO.	Part NO.	Part Name	Qty.
57	vBF-20.9-2	Screw	4
58	EB-500-E-4	Protection	1
59	GB/T96	Washer 6	2
60	GB/T6177	Nut M6	2
61	GB70+GB93+GB97	Screw M6×30	6
62	GB/T818	Screw M5×70	2
63	GB/T6170	M5 Nut	2
64	EB-500-E.2-1	Volute Case	1
65	EB-500-E.2.3	Impeller	1
66	GB70+GB93+GB97	Screw	4
67	EB-500-E.2-2	Volute Case	1
68	XSS46-2.2-5	Screw	10
69	GB70+GB93+GB97	Screw	6
72	vBF-14-9	Board	2
73	vBF-14B-4A	Support	1

NO.	Part NO.	Part Name	Qty.
74	GB70+GB93+GB97	Screw	4
75	vBF-14B-3	Board	3
76	vBF-14-12	Spring	1
77	250*4.5	Line	1
78	3F-30.17	Rubber Pillar	2
79	vBF-14-7	Frame	1
80	EB-650-10	Axis	2
81	EB-650.10	Gallus	2
82	vBF-14.7	Mat	1
83	vBF-2.6B-2	Plastic Clip	5
84	GB/T9074.4 M6×12	Screw	2
85	EB-500-E.4-1	Gasoline Tank	1
86	1E34F.9.2-3D	Filter	1
87	EB-415.4.2-2	Stopper	1
88	EB-415.4.2-4	Tube(180Mm)	1
89	CG420.1.3.2-2	Tube(350Mm)	1
90	GB/T 8870	Hoopø59-ø82	1
91	1E32FL.6.2	Lid	1
92	vBF-8.1-2A	Lid	1
93	vBF-8.1-1	Sealing Washer	1
94	vBF-14.3-1	Air Valve	1
95	vBF-14.3-3	Filter	1
96	GB/T13527.1 8×1.5×500	Tube	1
97	vBF-14B.2-1	Chemical Tank	1
98	vBF-3A.1-2	Sealing Washer	1
99	vBF-3A.1-1	Link Pipe	1
100	vBF-3A.1-3	Connector Lid	1
101	vB-16.4-2	Connector	1
102	vB-16.4-3	Sealing Washer	1
103	vB-16.4-1	Connector Lid	1
104	JB/T8870	Hoopø25-ø40	3
105	vBF-14B-5	Connector	1
106	vBF-16.2-1	Tube	1
107	vBF-3-3	Tube	4
108	vBF-950.2.1-2	Loop	1
109	vBF-950.2.1-1	Connector Lid	1
110	vBF-16.2-3	Tube	1
111	GB/T13527.1 10×1.5×830	Tube	1
112	GB/T13527.1 10×1.5×880	Tube	1
113	vBF-16.3-1	Plug	1
114	vBF-950.1.1-1	Tube	1
115	vBF-16.3.1-3	Board	1
116	vBF-14B.1.1-1	Elbow	1

NO.	Part NO.	Part Name	Qty.
118	vBF-16.3.1-2A	Switch	1
119	GB/T 8870	Hoop ϕ 78- ϕ 102	1
120	vBF-3.19.4	Tube	1
121	vBF-2.6.4.1	Connector	1
122	vBF-2.6.4-2	Tube	1
123	vBF-2.6.4-4	Tube	1
124	vBF-2.6.4-3	Tube	1
125	vBF-3.19.3-3	Valve	1
126	GB1235 16 \times 2.4	Sealing Washer	1
127	vBF-2.6.4.3-1	Nozzle	1
128	vBF-2.6.4.3.1.1	Nozzle	1
129	vBF-2.6.4.3.1-1	Washer	1
130	vBF-2.6.4.3.1-3	Rotation Impeller	1
131	vBF-2.6.4.3.1-2	Seat	1
132	vBF-2.6.4.3.1	Nozzle	1
133			
134	vB-15A-3	Line	1
135	vBF-14B.3.1.1	Line	1
136	CG328.1.1-4	Tube	1
137	GB/T 845	St5.5*25 Screw	1
138	GB/T 845	St4.2*19 Screw	5
139	vBF-14.5.1-2	Handgrip	1
140	vBF-14.5.1-7	Spring	1
141	vBF-14.5.1-3	Handgrip	1
142	GB/T6172.2	M6 Nut	1
143	vBF-14.5.1-8	Washer	1
144	GB/T955	Washer	1
145	vBF-14.5.1-1	Handgrip	1
146	vBF-14.5.1-10	Handgrip	1
147	vBF-14.5.1-9	Screw	1
148	vBF-14.5.1-5	Switch	1
149	vBF-14.5.1-4	Patch	1
150	vBF-3.19.1-1	Core	1
151	vBF-14.5.1.2-1	Seat	1
152	vBF-3.19.1-2	Shell	1
153	GB/T 845	St4.2X8 Screw	1
154	GB/T828	M3X5X2.5 Screw	2
155	GB/T845	St4.8*13 Screw	1
156	vBF-3.19.1	Cock Assem(No Board)	1
157	vB Z-4.15.1	Spanner	1
158	vB F-3.25.4	Chain	1
159	ZB4-10.1	Oil Bottle	1
160	vB F-14.5.1-6	Sheath	1