

# Owner's Manual

Infrared Ear Thermometer

Model 40-500-000

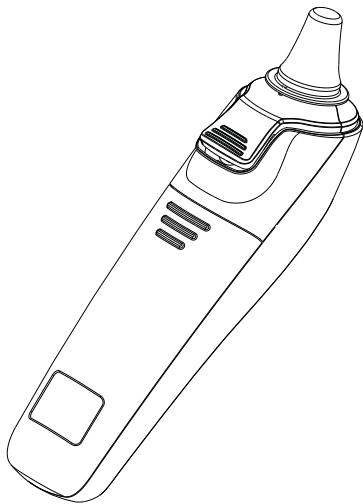

Document No.: DET-0304-002  
Article No.: 001  
Version: A  
Date of Issue: 2016-03

## Contents

Introduction .....	02
Product Description .....	03
Lcd Display Introduction .....	04
Basic Functions .....	05
Ear Thermometer Advantages .....	06
Body Temperature .....	06
Real Time Clock Setting .....	09
Illustration For Use .....	11
Temperature Taking Hints .....	15
Memory Mode .....	17
Selecting A Temperature Scale .....	18
Care And Cleaning .....	19
Battery Replacement .....	21
Specifications .....	22
Troubleshooting .....	23
Calibration .....	25
Service .....	26
Warranty .....	27
FCC Information .....	28
Electromagnetic Compatibility Information .....	29

## Introduction

The 40-500-000 thermometer is specifically designed for safe use in the eardrum. The Infrared Ear Thermometer is a device capable of measuring people's body temperature by detecting the intensity of infrared light emitted from the ear canal of human. It converts the measured heat into a temperature reading displayed on the LCD. When properly used, it will quickly assess your temperature in an accurate manner.



Please read all instructions carefully and thoroughly before using this product.

### Important:

1. This thermometer is intended for home use only. It's not meant to replace a visit to the doctor. Please consult with doctor if you have health concerns.
2. There is no gender or age limitation for using infrared ear thermometer.
3. To avoid inaccurate readings, always attach a new, clean probe cover for each temperature reading.
4. Do not expose the thermometer to temperature extremes (below  $-25^{\circ}\text{C}/-13^{\circ}\text{F}$  or over  $55^{\circ}\text{C}/131^{\circ}\text{F}$ ) nor excessive humidity ( $>95\%RH$ ).
5. This thermometer must only be used with this brand thermometer probe covers.
6. Keep the battery away from children.

## Product Description

1. Probe Cover
2. Probe
3. Blue Operating Button
4.  Button
5. Battery Cover

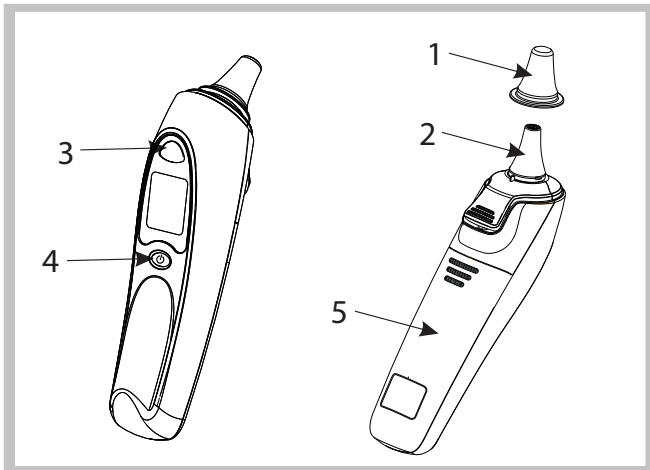

3

## LCD Display Introduction

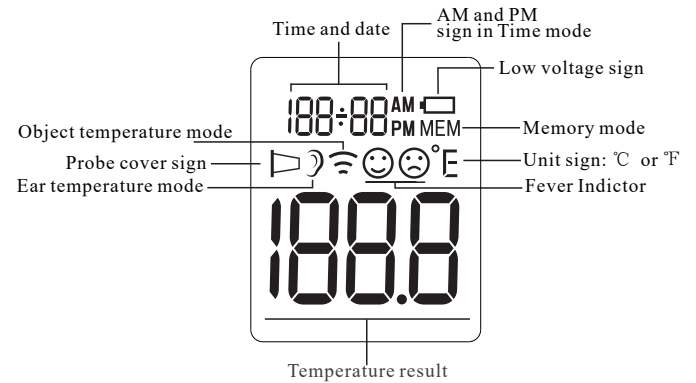

4

## Basic Functions

Real Time Clock	The real time clock will be recorded with the memory function and help you to recognize each measurement result. Please see the Real time clock setting section to learn how to setup the time in the first use.
Ear Temperature Mode	The thermometer has been designed for practical use. It's not meant to replace a visit to the doctor. Please also remember to compare the measurement result to your regular body temperature. Please see the Illustration For Use section to learn how to measure the body temperature.
Probe cover eject function	The thermometer has been designed for use with or without probe cover. Users can press the eject button to remove the probe cover.
Object Temperature Mode	The object mode shows the actual, unadjusted surface temperatures, which is different from the body temperature. It can help you to monitor if the object temperature is suitable for the baby or patient, for example the baby's milk. Please see the Illustration For Use section to learn how to measure the object temperature.
Fever Alarm	If thermometer detects a body temperature $\geq 37.8^{\circ}\text{C}(100.0^{\circ}\text{F})$ under ear mode, there will be a long beep sound followed by three short beep sound to warn the user for potential fever.
Memory Mode	There are each 10 sets memories for ear and object measurements. Each memory also records the measurement date/time/mode icon.
°C/°F Switch	Please see the Selecting Temperature Scale section to learn how to change between Celsius and Fahrenheit.
Probe Cover Automatic Detection	Automatic detection function, convenient for test with or without probe cover.

5

## Ear Thermometer Advantages

Infrared Ear Thermometer measures core body temperature, which is the temperature of a body's vital organs. (See Figure 1) Ear temperatures accurately reflect core body temperatures since the eardrum is in the cranial cavity and is not affected by the environment. The eardrum shares blood supply with the hypothalamus (part of the brain.) Therefore, body temperature changes are reflected sooner in the ear than they are in other parts of the body.

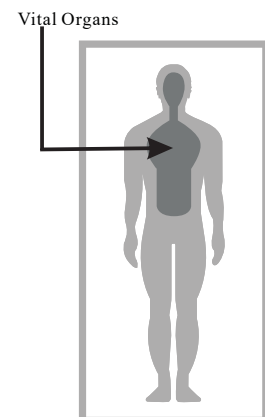

Figure 1

6

## Ear Thermometer Advantages

Clinical studies have shown that the ear is an excellent site for temperature measurement because temperatures taken in the ear reflect the body's core temperature. Body temperature is regulated by the hypothalamus, which shares the same blood supply as the tympanic membrane. Changes in core body temperature are usually seen sooner at the tympanic membrane than at other sites, such as the rectum, mouth or under the arm.

Advantages of taking temperatures at the ear versus other sites:

- Axillary temperature readings only reflect skin temperature which may not indicate the internal body temperature.
- Rectal temperatures often lag significantly behind internal body temperature changes, especially at times of rapidly changing temperatures.
- Oral temperatures are often influenced by eating, drinking, thermometer placement, breathing through the mouth, or the inability of the person to close their mouth completely.

7

## Body Temperature

Normal body temperature is a range. The following table shows that ranges of normal temperature also vary by site. Therefore, readings from different body locations, even taken at the same time, should not be directly compared.

Normal ranges by body locations:

Axillary	34.7 - 37.3°C	94.5 - 99.1°F
Oral	35.5 - 37.5°C	95.9 - 99.5°F
Rectal	36.6 - 38.0°C	97.9 - 100.4°F
Ear	35.8 - 38.0°C	96.4 - 100.4°F

Also, a person's normal temperature range tends to decrease with age. The following table shows normal ranges by age:

0-2 Years	36.4 - 38.0°C	97.5 - 100.4 °F
3-10 Years	36.1 - 37.8°C	97.0 - 100.0 °F
11-65 Years	35.9 - 37.6°C	96.6 - 99.7 °F
Over 65 Years	35.8 - 37.5°C	96.4 - 99.5 °F

The range of normal temperature varies from person to person and can be influenced by many factors such as time of day, level of activity, medications and gender.

8

## Real Time Clock Setting

When using thermometer for the first time, please set the parameters of the thermometer. With the thermometer off, press and hold **ON** BUTTON to enter into setting mode for 3 seconds.

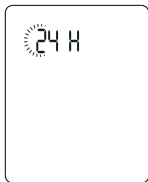

- ① Set the time format  
The device can display the time in either an AM/PM (12-hour) or a 24:00(24-hour) format. Press and release **BLUE** BUTTON to select the format. With the preferred time format on the display, press **ON** BUTTON, the Hour figure is flashing automatically.



- ② Set the hour  
Press and release the **BLUE** BUTTON to advance one hour until the correct hour appears. After the hour is set, press **ON** BUTTON, the Minute figure is flashing automatically.



- ③ Set the minute  
Press and release the **BLUE** BUTTON to advance one minute until the correct minute appears. After the minute is set, press **ON** BUTTON, the Year figure is flashing automatically.

9

## Real Time Clock Setting



- ④ Set the year  
Press and release the **BLUE** BUTTON to advance one year until the correct year appears. After the year is set, press **ON** BUTTON, the Month figure will appear.



- ⑤ Set the month  
Press and release the **BLUE** BUTTON to advance one month until the correct month appears. After the month is set, press **ON** BUTTON, the Date figure is flashing automatically.



- ⑥ Set the date  
Press and release the **BLUE** BUTTON to advance one day until the correct month appears. After the day is set, press **ON** BUTTON to exit the setting mode.

10

## Illustration For Use

### ► To measure ear temperature:

1. To achieve accurate readings, make sure a new, clean probe cover is in place before each measurement. Place a new probe cover on the probe firmly; making sure the probe and the inner portion of the probe cover fit snugly.
2. Press the **⏻** BUTTON, The display is activated to show all segments. After self-checking Figure 2 appears on the display screen with beeps, so you can start a new measurement. If error messages appears, it means the thermometer is not ready for measurement.

#### Remarks:

- a. Probe cover sign stand for taking the ear temperature with probe cover now and vice versa.
- b. To avoid the risk of cross contamination, it is recommended that you always measure the ear temperature with probe cover.

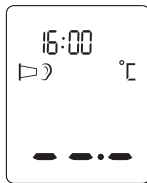

Figure 2

11

## Illustration For Use

3. Insert the probe along the ear canal as deep as possible into the ear as depicted in Figure 3. Then press the **BLUE BUTTON** once to start the measurement. A long beep will sound approximately 1 second after the **BLUE BUTTON** is activated. This signals the end of the process as results are displayed on the LCD screen.
4. The thermometer is ready for testing again once an ear mark displays on the LCD. A waiting period of 20 seconds between testing is recommended to avoid excessive cooling of the skin.
5. The thermometer will shut off automatically after 60 seconds of inactivity. To prolong battery life, press the **⏻** BUTTON to turn the unit off.

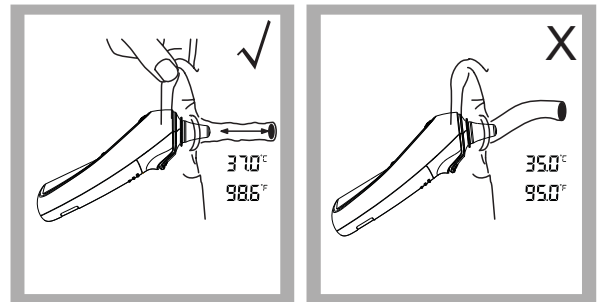

Figure 3

12

## Illustration For Use

### ► To measure object temperature:

1. First eject the probe cover.
2. Aim the thermometer at the center of the object you want to measure with a distance of 1 to 2 cm.
3. Press the **⏻** BUTTON to turn on the thermometer, you can take the object temperature after hearing two beep sounds. (see figure 4)

#### Remarks:

This mode shows the actual, unadjusted surface temperatures, which is different from the body temperature.

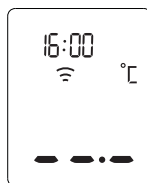

Figure 4

### ► How to change the ear mode and object mode:

You can press and hold **⏻** B U T T O N and then press and hold the **BLUE BUTTON** to switch the mode between ear mode and object mode.

13

## Illustration For Use

### ► After measurement:

1. Power off: Device will automatically shut off if left idle for more than 1 minute to extend battery life.
2. Clean the probe after each use to ensure an accurate reading and avoid cross contamination. (See the section of Care and Cleaning for details.)

### ► Fever indicator:

#### In Ear mode:

1. If the temperature reading is below 37.8°C (100.0°F), a happy face 😊 will be displayed next to the reading.
2. If the temperature reading is 37.8°C (100.0°F) or above, a bad face 😞 will be displayed next to the reading.

14

## Temperature Taking Hints

1. The right ear reading may differ from the reading taken at the left ear. Therefore, always take the temperature in the same ear.
2. The ear must be free from obstructions or excess earwax buildup to take an accurate reading.
3. External factors may influence ear temperatures such as:
  - lying on one ear or the other
  - their ears covered
  - exposed to very hot or very cold temperatures
  - recently swimming or bathing

In these cases, remove the individual from the situation and wait 20 minutes prior to taking a temperature.
4. For persons wearing hearing aids or ear plugs, remove the device and wait 20 minutes prior to taking a temperature.
5. When using the thermometer on infants under age 1, pull the ear up making sure the sensor faces the eardrum. (See Figure 5)

15

## Temperature Taking Hints

6. When using the thermometer on individuals over the age of 1, pull the ear back making sure the sensor faces the eardrum. (See Figure 6)
7. Do not touch the probe window. A cotton swab and rubbing alcohol may be used to clean the sensor window.
8. If the thermometer is stored in a significantly different environment than testing location, place it in the testing location for approximately 30 minutes prior to use.

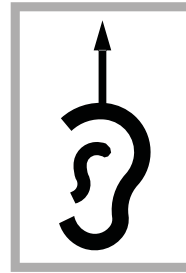

Figure 5

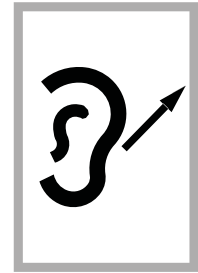

Figure 6

16

## Memory Mode

1. The Memory Mode can be accessed either in ear mode or object mode:  
When the thermometer has been turned on and followed by Figure 3 or finished testing, press and hold the **⏻** Button for three seconds. The letter MEM will appear in the center left corner of the display. (See Figure 7)
2. The thermometer will automatically memorize the last 10 temperature readings. Each memory also records the measurement date/time/mode icon. Each time the **⏻** Button is pressed, the screen displays past readings that correspond with a number 1-10. The number 1 reflects the most recent reading, while the number 10 reveals the oldest reading stored in memory. (See Figure 8)
3. In the memory mode, ear mark or scan mark always exist. The user can press the BLUE BUTTON to take new measurements.

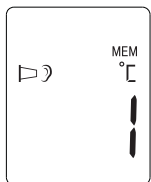

Figure 7

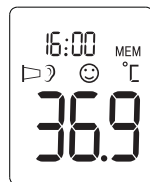

Figure 8

17

## Selecting A Temperature Scale

1. Temperature readings are available in the Celsius (°C) or Fahrenheit (°F) scale.
2. With the unit off, press and hold the BLUE BUTTON for 3 seconds to enter into unit changing mode.
3. Press and release BLUE BUTTON to select the unit.
4. When the preferred unit on the display, press **⏻** BUTTON to exit the unit changing mode.

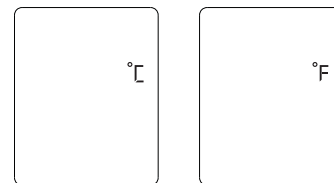

Figure 9

18

## Care And Cleaning

1. Probe covers are intended for single use only!  
Absent, damaged, perforated, or soiled probe covers can lead to inaccurate temperature readings.
2. The probe window must be kept clean, dry, and undamaged at all times to ensure accurate readings. The accuracy of temperature readings can be affected by damage to the probe window, or the presence of dirt and ear wax on the probe window.
3. Fingerprints, earwax, dust and other soiling compounds reduce transparency of the window and result in lower temperature readings. If the thermometer is accidentally placed in the ear without a probe cover installed, the window must be cleaned immediately.
4. The probe window is the most delicate part of the thermometer. To safely clean the window, gently wipe its surface with a cotton swab slightly moistened with isopropyl alcohol and immediately wipe dry with a clean cotton swab. After cleaning, allow at least 5 minutes drying time before taking temperatures.  
Note: Do not use any chemical other than isopropyl alcohol to clean the probe window.
5. Use a soft, dry cloth to clean the thermometer display and exterior.
6. The thermometer is not waterproof. Do not submerge the unit in water when cleaning.

19

## Care And Cleaning

7. Store the thermometer and probe cover in a dry location, free from dust and contamination and away from direct sunlight.
8. Periodic cleaning and disinfection of the device following use to prevent patient cross infection.  
-Use a soft cloth slightly moistened with a 70% isopropyl alcohol solution to disinfect the thermometer and probe. Do not use abrasive cleaners.
9. Ensure that children do not use the instrument unsupervised; some parts are small enough to be swallowed.
10. Do not remove or modify the equipment without permission.
11. Strong electromagnetic fields may interfere with the proper operation of the thermometer. The device needs special pre-cautions regarding EMC according to the EMC information.

20

## Battery Replacement

1. Replace battery when "  " appears in the upper right corner of LCD display. (See Figure 10)
2. Slide battery cover down as shown in Figure 11.
3. Remove battery and install 2 new AAA alkaline batteries as shown in Figure 12.
4. Slide battery cover back on.



Figure 10

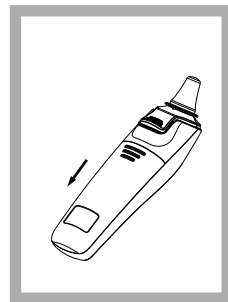

Figure 11

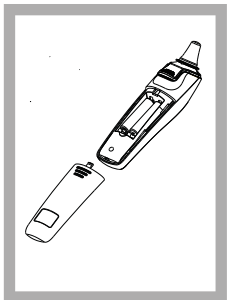

Figure 12

21

## Specifications

Measuring range	Ear mode: 28.0°C~43.0°C (82.4°F~109.4°F) Object mode: -20°C~100°C (-4°F~212°F) Room temperature: 0°C~50°C (32°F~122°F)
Measuring site	Ear canal(Ear Mode)
Reference body site	Oral (This thermometer converts the ear temperature to display its "oral equivalent.")
Operation mode	Ear mode(Adjust mode)
Laboratory accuracy	Ear mode: ±0.2°C (0.4°F) during 35.5°C~42.0°C (95.9°F~107.6°F) at 15°C~35°C (59.0°F~95.0°F) operating temperature range ±0.3°C (0.5°F) for other measuring and operating temperature range Object mode: ±4% or ±2°C (4°F) whichever is greater Room temperature: ±2°C (±4°F)
Display resolution	0.1°C or 0.1°F
Measure time	Approximately one second
Operating temperature range:	Ear/Object mode: 10°C~40°C (50°F~104°F), 15%~85%RH, non-condensing Atmospheric Pressure : 700hPa ~ 1060hPa
Storage and transport temperature range	-25°C~ 55°C (-13°F~ 131°F), 15%~95%RH, non-condensing Atmospheric Pressure : 700hPa ~ 1060hPa
Clinical accuracy	Clinical bias: 0.08°C (0.14°F) Clinical repeatability: 0.13°C (0.23°F) Limits of agreement:0.73°C (1.31°F)
Shock	withstands drop of 3 feet
Dimension	155 x 38x 47mm
Weight	Approx.83grams(with batteries)
Battery	DC3V(2×AAA battery)
Battery life	Approx. 1 year/6000 readings
Expected service life	Three years
Ingress protecting rating	IP22

22

## Troubleshooting

Error message	Problem	Solution
Er 1	Measurement before thermometer is ready	Take a measurement until $\varnothing$ or $\infty$ appears on the display.
Er 2	The ambient temperature is not within the range between 10°C and 40°C (50°F~104°F).	Place the thermometer in a room for at least 30 minutes at room temperature between 10°C and 40°C (50°F~104°F)
Er 3	The thermometer is placed incorrectly or unsteady.	Read Illustration For Use thoroughly and take a new temperature measurement.
Er 4	The thermometer showing a rapid ambient temperature change.	Allow the thermometer to rest in a room for at least 30 minutes at room temperature: between 10°C and 40°C (50°F~104°F)
Er 5	The thermometer is not functioning properly.	Unload the battery, wait for 1 minute and repower it. If the message reappears, contact the retailer for service.

23

## Troubleshooting

Error message	Problem	Solution
Er 6	In object temperature mode, measurement with probe cover.	Remove probe cover in object temperature mode.
H <sub>1</sub>	In Ear mode: Temperature taken is higher than 43.0 °C (109.4°F). In Object mode: Temperature taken is higher than 100 °C (212°F).	Read Temperature Taking Hints Thoroughly, then check the integrity of the probe cover and take a new temperature measurement.
Lo	In Ear mode: Temperature taken is lower than 28.0 °C (82.4°F). In Object mode: Temperature taken is lower than -20 °C (-4°F).	Read Temperature Taking Hints thoroughly, then make sure the probe cover and lens filter are clean, then take a new temperature measurement.
	The thermometer could not work due to low battery.	Replace two new alkaline batteries size AAA.

24

## Calibration

The thermometer is initially calibrated at the time of manufacture. If the thermometer is used according to the use instruction, periodic readjustment is not required. However, We recommends checking calibration every two years or whenever clinical accuracy of the thermometer is in question. Please send the complete device to the dealers or manufacturer.

The above recommendations do not supersede the legal requirements. The user must always comply with legal requirements for the control of the measurement, functionality, and accuracy of the device which are required by the scope of relevant laws, directives or ordinances where the device is used.

A clinical summary and procedures for checking calibration are available upon request. (Turn on the thermometer and press the power button long time until entering into calibrate mode, software version will be displayed.)

ASTM laboratory accuracy requirements in the display range of 36.0 to 39.0 °C (96.8 to 102.2 °F) for IR thermometers is  $\pm 0.2^\circ\text{C}$  ( $\pm 0.4^\circ\text{F}$ ), whereas for mercury-in-glass and electronic thermometers, the requirement per ASTM Standards E 667-86 and E 1112-86 is  $\pm 0.1^\circ\text{C}$  ( $\pm 0.2^\circ\text{F}$ ).



Type BF applied part

 Direct Current



Disposal of this product and used batteries should be carried out in accordance with the national regulations for the disposal of electronic products



Consult Accompanying Documents



Batch Code



Storage and Transportation Temperature Limit:  
-4°F ~ 131°F (-20°C ~ 55°C)

25

## Service

The thermometer has a limited one year warranty. Do not attempt to disassemble or repair the thermometer by yourself. Should service be required during or after the warranty period you must contact the manufacturer. Repackage the thermometer carefully in its original packaging or securely pack to avoid damage during shipping. Include the original sales slip indicating the date of purchase, a note describing the problem, and your return address. Send the thermometer prepaid and insured.

The lay operator or lay responsible organization should contact the manufacturer or the manufacturer's representative:

- for assistance, if needed, in setting up, using or maintaining the thermometer; or
- to report unexpected operation or events.

Distributed by:  
BV Medical  
28W206 Commercial Ave., Unit B  
Lake Barrington, IL 60010  
www.bvmedical.com  
Toll Free: (888) 822-8293  
Email: info@bvmedical.com



Manufactured by Hangzhou Sejoy Electronics & Instruments Co., Ltd.  
Building 2, No.202, Zhenzhong Road, West Lake  
Economy & Technology Zone 310030 Hangzhou China

Made in China

26

## Warranty

This appliance conforms to the following standards:  
 ASTM E1965-98 Standard Specification for Infrared Thermometers for Intermittent Determination of Patient Temperature,  
 ISO 80601-2-56 Medical electrical equipment —Part 2-56: Particular requirements for basic safety and essential performance of clinical thermometers for body temperature measurement,  
 IEC 60601-1-11 Medical electrical equipment —Part 1-11: General requirements for basic safety and essential performance –Collateral Standard: Requirements for medical electrical equipment and medical electrical systems used in the home healthcare environment and complies with the requirements of IEC 60601-1-2(EMC) ,  
 AAMI/ANSI ES60601-1(Safety) standards. And the manufacturer is ISO 13485 certified.

Thermometer is warranted by manufacture to be free from defects in material and workmanship under normal use and service for a period of one year from the date of delivery to the first user who purchases the instrument. This warranty does not cover batteries, damage to the probe window, or damage to the instrument caused by misuse, negligence or accident, and extends to only to the first purchaser of the product. Additionally this warranty becomes void, if the thermometer is operated with anything other than this brand thermometer probe covers.

## FCC Information

Caution: Changes or modifications to this unit not expressly approved by the party responsible for compliance could void the user authority to operate the equipment.

\*Note:

This equipment has been tested and found to comply with the limits for a Class B digital device, pursuant to Part 15 of the FCC Rules. These limits are designed to provide reasonable protection against harmful interference in a residential installation. This equipment generates, uses, and can radiate radio frequency energy. If this equipment does cause harmful interference to radio or television reception, which can be determined by turning the equipment off and on, the user is encouraged to try and correct the interference by one or more of the following measures:

- Reorient or relocate the receiving antenna.
- Increase the distance between the equipment and the receiver.
- Connect the equipment to an outlet on a circuit different from that to which the receiver is connected.
- Consult the dealer or an experienced radio/TV technician for help.

## Electromagnetic Compatibility Information

The device satisfies the EMC requirements of the international standard IEC 60601-1-2. The requirements are satisfied under the conditions described in the table below. The device is an electrical medical product and is subject to special precautionary measures with regard to EMC which must be published in the instructions for use. Portable and mobile HF communications equipment can affect the device. Use of the unit in conjunction with non-approved accessories can affect the device negatively and alter the electromagnetic compatibility. The device should not be used directly adjacent to or between other electrical equipment.

## Electromagnetic Compatibility Information

Table 1

Guidance and declaration of manufacturer-electromagnetic emissions		
The device is intended for use in the electromagnetic environment specified below. The customer or the user of the device should assure that it is used in such an environment.		
Emissions test	Compliance	Electromagnetic environment-guidance
RF emissions CISPR 11	Group 1	The device uses RF energy only for its internal function. Therefore, its emissions are very low and are not likely to cause any interference in nearby electronic equipment.
RF emissions CISPR 11	Class B	The device is suitable for use in all establishments, including domestic establishments and those directly connected to the public low-voltage power supply network that supplies buildings used for domestic purposes.
Harmonic emissions IEC 61000-3-2	N/A	
Voltage fluctuations/ flicker emissions IEC 61000-3-3	N/A	



# Electromagnetic Compatibility Information

# Electromagnetic Compatibility Information

Table 2

Guidance and declaration of manufacturer-electromagnetic immunity			
The device is intended for use in the electromagnetic environment specified below. The customer or the user of the device should assure that it is used in such an environment.			
IMMUNITY test	IEC 60601 test level	Compliance level	Electromagnetic environment guidance
Electrostatic discharge (ESD) IEC 61000-4-2	± 6 kV contact ± 8 kV air	± 6 kV contact ± 8 kV air	Floors should be wood, concrete or ceramic tile. If floors are covered with synthetic material, the relative humidity should be at least 30 %.
Electrostatic transient/burst IEC 61000-4-4	± 2 kV for power supply lines ± 1 kV for input/output lines	N/A	
Surge IEC 61000-4-5	± 1 kV differential mode ± 2 kV common mode	N/A	
Voltage dips, short interruptions and voltage variations on power supply input lines IEC 61000-4-11	< 5% UT (>95% dip in UT) for 0.5 cycle 40% UT (60% dip in UT) for 5 cycle 70% UT (30% dip in UT) for 25 cycle < 5% UT (>95% dip in UT) for 5 sec	N/A	
Power frequency (50/60 Hz) magnetic field IEC 61000-4-8	3 A/m	3 A/m	Power frequency magnetic fields should be at levels characteristic of a typical location in a typical commercial or hospital environment.

Table 3

Guidance and declaration of manufacturer-electromagnetic immunity			
The device is intended for use in the electromagnetic environment specified below. The customer or the user of the device should assure that it is used in such an environment.			
IMMUNITY test	IEC 60601 test level	Compliance level	Electromagnetic environment guidance
Conducted RF IEC 61000-4-6	3 Vrms 150 kHz to 80 MHz	N/A	Portable and mobile RF communications equipment should be used no closer to any part of the device, including cables, than the recommended separation distance calculated from the equation applicable to the frequency of the transmitter.
Radiated RF IEC 61000-4-3	3 V/m 80 MHz to 2.5 Ghz	3 V/m	<p>Recommended separation distance</p> $d = \left[ \frac{3.5}{E_1} \right] \sqrt{P} \quad 80 \text{ MHz to } 800 \text{ MHz}$ $d = \left[ \frac{7}{E_1} \right] \sqrt{P} \quad 800 \text{ MHz to } 2.5 \text{ Ghz}$ <p>where P is the maximum output power rating of the transmitter in watts (W) according to the transmitter manufacturer and d is the recommended separation distance in metres (m).</p> <p>Field strengths from fixed RF transmitters, as determined by an electromagnetic site survey, should be less than the compliance level in each frequency range.</p> <p>Interference may occur in the vicinity of equipment marked with the following symbol:</p> 

# Electromagnetic Compatibility Information

Table 4

Recommended separation distances between portable and mobile RF communications equipment and the device		
The device is intended for use in an electromagnetic environment in which radiated therefore disturbances are controlled. The customer or the user of the device can help prevent electromagnetic interference by maintaining a minimum distance between portable and mobile RF communications equipment (transmitters) and the device as recommended below, according to the maximum output power of the communications equipment.		
Rated maximum output power of transmitter W	Separation distance according to frequency of transmitter m	
	80 MHz to 800 MHz $d = \left[ \frac{3.5}{E_1} \right] \sqrt{P}$	800 MHz to 2.5 GHz $d = \left[ \frac{7}{E_1} \right] \sqrt{P}$
0.01	0.12	0.23
0.1	0.38	0.73
1	1.2	2.3
10	3.8	7.3
100	12	23

For transmitters rated at a maximum output power not listed above, the recommended separation distance d in metres (m) can be estimated using the equation applicable to the frequency of the transmitter, where P is the maximum output power rating of the transmitter in watts (W) according to the transmitter manufacturer.

NOTE1 At 80 MHz and 800 MHz, the separation distance for the higher frequency range applies.

NOTE2 These guidelines may not apply in all situations. Electromagnetic propagation is affected by absorption and reflection from structures, objects and people.