

INDICE

Index



CHI SIAMO
WHO WE ARE

Pag. 4



ECO-FRIENDLY
ATTITUDE

Pag. 7

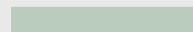

SISTEMI
BREVETTATI
PATENTED
SYSTEMS

Pag. 9



#WEAREATK

Pag. 14

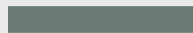

SIGNATURE
EDITIONS

Pag. 15



ATTACCHI
BINDINGS

Pag. 17

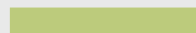

ACCESSORI
ACCESSORIES

Pag. 75



RICAMBI
SPARE PARTS

Pag. 77



ATTREZZI
TOOLS

Pag. 79



MERCH & POP

Pag. 79



DISTRIBUTORI
DISTRIBUTORS

Pag. 81



CARTA
PAPER

Pag. 83

PERFORMING THROUGH LIGHTNESS

30 anni di esperienza nella lavorazione a CNC delle leghe aeronautiche per raggiungere una leggerezza ineguagliabile sul mercato: solo gli attacchi ATK Bindings garantiscono un approccio alla montagna leggero, affidabile e divertente.

With over 30 years experience in CNC machining of aeronautical alloys, ATK Bindings technology delivers unparalleled lightness, which is why ATK Bindings provide the lightest, most reliable and enjoyable products for the best mountaineering experience.



CHI SIAMO Who we are

MISSION

**Fare attacchi è il nostro mestiere,
l'eccellenza il nostro obiettivo.**

Binding manufacturing is what we do,
excellence is our goal.

SIAMO UN'AZIENDA DI FAMIGLIA

La nostra sede e il nostro stabilimento produttivo hanno sede a Fiorano Modenese, nel cuore della Motor Valley, dove innovazione e prodotti meccanici di altissima qualità sono concepiti, sviluppati, realizzati ed esportati in tutto il mondo ogni giorno.

Know-how e passione per i prodotti di alta qualità sono le basi su cui Giovanni Indulti ha fondato ATK Bindings nel 2007. L'esperienza coltivata e tramandata di generazione in generazione e un costante lavoro di squadra hanno portato ATK Bindings a raggiungere in pochi anni una posizione di rilievo nel mercato, distinguendosi per le soluzioni innovative, la qualità, la precisione e la leggerezza unica dei suoi prodotti.

WE ARE A FAMILY COMPANY

Our headquarters and manufacturing facilities are located in Fiorano Modenese, in the heart of the famous Italian Motor Valley, where innovation, engineering and high-quality mechanical products are designed, manufactured and exported everyday across the globe.

The know-how and passion for high quality products inspired founder Giovanni Indulti to start ATK Bindings in 2007. Expertise handed down from generation to generation, combined with an effective teamwork, led ATK Bindings to reach a prominent position in the market and becoming famous for its innovative solutions, high quality products praised for precision and unique lightness.

PUNTI DI FORZA

Our strenghts

ESCLUSIVITÀ

Nati da una passione genuina tramandata di generazione in generazione, i prodotti ATK Bindings fondano la propria identità sull'eccellenza: leggerezza incomparabile, elevata qualità e funzionalità danno vita a un prodotto esclusivo destinato ad offrire le migliori performance di sempre.

EXCLUSIVITY

A passion handed down from generation to generation, ATK Bindings products strive for excellence: incomparable lightness combined with functionality and high quality components, delivering a performing and one-of-a-kind product.

INNOVAZIONE

Abbiamo un carattere fortemente orientato all'innovazione e alla continua ricerca in campo tecnologico, dalla sperimentazione sui metodi produttivi fino all'esplorazione di nuovi sistemi brevettati. I componenti strutturali degli attacchi ATK Bindings sono ricavati dal pieno, tramite lavorazione CNC, per ottenere la massima affidabilità e precisione e l'impareggiabile leggerezza che li ha resi famosi in tutto il mondo.

INNOVATION

We focus on innovation and our research covers all sectors, from production to the development of new patents. The components of ATK Bindings are crafted from solid blocks of aluminium with CNC technology and are designed to be reliable and extremely light, which is what made them famous the world over.

ARTIGIANALITÀ

L'unione esemplare tra le tecniche di lavorazione di un'azienda artigiana con le più moderne tecnologie industriali: un risultato che abbiamo raggiunto nel tempo con grande determinazione e che rappresenta uno dei valori principali del brand ATK Bindings. Dalla progettazione alla produzione, fino all'assistenza post vendita: tutto è analizzato ed eseguito con massima cura e precisione.

CRAFTSMANSHIP

ATK Bindings skilfully combines the values and techniques of handcraft with state-of-the-art technology. This achievement is a source of pride and has become one of the main assets of the brand. From design and production to after-sales service, everything is assessed and executed with the utmost attention to detail and precision.

MADE IN ITALY

L'intero processo produttivo, dal concept al prodotto finito, viene realizzato da ingegno e manualità Made in Italy, a garanzia dei massimi standard qualitativi, innovazione e design. ATK Bindings è una delle aziende che più ha contribuito a rivoluzionare il mondo dello scialpinismo e ad aumentare significativamente il livello dei materiali tecnici in circolazione, dimostrando che il Made in Italy è un importante valore aggiunto.

The whole production is inspired by Italian talent and craftsmanship and guarantees the highest standards of innovation and design.

ATK Bindings is one of the leading companies and revolutionised the world of ski mountaineering by enhancing the quality of components, the proof that the "Made in Italy" branding is still an important added value.

SERVICE: QUALITÀ A 360 GRADI

Prodotti dal valore tecnologico elevato necessitano di un servizio post vendita allo stesso livello. Le competenze tecniche, l'aggiornamento professionale costante del personale, la personalizzazione dei servizi e la rapidità di intervento, sono tra i punti di forza che maggiormente ci hanno permesso di conquistare la fiducia di tutti i clienti che richiedono prestazioni di alto livello, risposte e soluzioni efficaci e risolutive.

SERVICE : 360° QUALITY

The best products require top quality after-sales service. Technical training - which our employees undergo on a regular basis - together with a quick and tailored service are just a few of the many assets that have enabled us to gain our customers' trust. We aim to offer fast and first-rate assistance.



ECO-FRIENDLY ATTITUDE

VERSO UN FUTURO A IMPATTO ZERO

Essere un'azienda innovativa significa prima di tutto essere un'azienda responsabile, pioniera di una cultura sostenibile, pronta a mettere in campo investimenti lungimiranti per il bene dei lavoratori, dei consumatori e del mondo che ci ospita.

Il nostro obiettivo quotidiano è quello di creare un ambiente funzionale e attento al risparmio energetico sia in termini di illuminazione, riscaldamento e raffrescamento degli ambienti di lavoro, sia in termini di produzione. I nostri attacchi sono espressione della nostra naturale attitudine alla sostenibilità: prendono vita in natura, tra cime innevate e imponenti montagne e, alla natura, portano il rispetto che merita.

Ci impegniamo giorno dopo giorno per raggiungere l'obiettivo di diventare una realtà produttiva Carbon Neutral entro il 2025: ogni piccolo gesto contribuisce a lasciare un'impronta importante in questo stimolante e necessario percorso verso un futuro a impatto zero.

CARBON NEUTRAL FUTURE

An innovative firm is also a responsible one: we are pioneers of a sustainable approach to production and we are ready to plan long-term investments for the good of our employees, our customers and the planet.

We are committed to decrease energy consumption by responsibly managing lighting, heating and air-conditioning in our premises. Our bindings express our dedication to sustainability: we owe respect to nature and its snow-capped mountain tops.

We strive to become Carbon Neutral by 2025, no matter how big or small, every single action is a fundamental step towards this exciting objective to achieve a zero-impact future.



Una buona parte dei componenti dei nostri attacchi è prodotta con l'utilizzo di energia pulita proveniente dai pannelli solari del nostro stabilimento.

Part of the components used in our bindings are produced using our solar panels which provide clean energy for the production.



Circa il 97% dei lubro-refrigeranti vengono recuperati e riutilizzati per processi interni.

Almost 97% of our machinery lubricants are collected and reused within the internal processes.



Tutte le acque di lavorazione vengono canalizzate in un circuito chiuso, l'unica dispersione avviene tramite evaporazione.

All processed water is recycled and the only dispersion occurs due to evaporation.



Il 100% dei trucioli di alluminio prodotti dai nostri macchinari vengono riciclati per produrre nuovo alluminio riutilizzabile.

100% of the chips produced by our machinery are recycled for the production of aluminium.

REPAIR

Una delle azioni più responsabili che possiamo compiere per essere un'azienda sostenibile è quella di fare prodotti di altissima qualità e che durano nel tempo. Possedere un attacco ATK Bindings significa avere accesso ad un servizio di assistenza senza limiti di tempo: non esiste un attacco ATK Bindings che non possa essere riparato e noi offriamo questo servizio da sempre. Prendersi cura di un prodotto significa prendersi cura dell'ambiente che lo circonda.

Producing high-quality and durable products is how we keep committed to sustainability. By purchasing a pair of ATK Bindings customers have access to a unique assistance: all ATK Bindings can be repaired and we always provide this service. By taking care of our products we take care of the environment.

& RECYCLE

Per nuove esperienze di sciata e attacchi a fine vita abbiamo una soluzione! Con il progetto Recycle è possibile restituire uno qualsiasi dei nostri attacchi attraverso la Recycle Box e tramite i nostri rivenditori: dopo la raccolta ci impegneremo a riciclarli nella produzione di nuovi prodotti, smaltendo i componenti non utilizzabili. Insieme lasciamo un segno importante sulla strada verso la riduzione della carbon footprint.

For consumed bindings and new ski experiences we have a solution! With Recycle you can turn in your old bindings by placing them in the Recycle Box or directly handing them to our stores for recycling; non-reusable components will be disposed responsibly. Another step towards reducing our carbon footprint.



SISTEMI BREVETTATI

Patented systems

I sistemi brevettati sono il nostro valore aggiunto, sinonimo di innovazione ed esclusività.

Our patented systems are our asset, a synonym for innovation and exclusivity.

L'innovazione è da sempre il motore della nostra attività: attraverso un lavoro di ricerca instancabile e appassionato troviamo la risposta ad ogni esigenza, sia per la scelta dei materiali che per la funzionalità dei nostri prodotti.

Innovation has always been the driving force of our business. This is why ATK Bindings is different: through tireless and passionate research we satisfy any requirement, from the selection of materials to the functionality of products.



Il CAM RELEASE SYSTEM® è installato sulle talloniere per gestire lo step-in e lo sgancio verticale in caso di caduta. Uno speciale profilo a CAM viene premuto da una molla pretensionata verso i pin di aggancio della talloniera: in caso di step-in o sgancio in seguito ad una caduta, i pin vengono forzati a percorrere il profilo a CAM che risponde con una resistenza precisa al rilascio dei pin, a seconda del valore di sgancio tarato sulla talloniera.

The CAM RELEASE SYSTEM® is fitted inside of our touring bindings heel parts in order to drive the boot step-in and vertical release in case of fall. A special CAM profile is pressed towards the heel pins by a pre-tensioned spring: when the step-in or a fall release occur, the pins are forced to go through the CAM profile which provides a precise resistance to the pin release, depending on the release value set on the binding.

- Garantisce la migliore performance di discesa sul mercato con una consistente riduzione della torsione dello scarpone in rapporto a qualsiasi altra talloniera tech.
 - Performance di sgancio estremamente precisa.
 - Garantisce lo step-in della talloniera più morbido del settore.
 - Dimensioni estremamente contenute che garantiscono una leggerezza strabiliante.
-
- Provides the best downhill performance on the market, with consistent and unrivalled reduction of boot-torsion.
 - Extremely precise release performance.
 - Provides the easiest step-in heel in the sector.
 - Compact dimensions and exceptionally light.



Quando lo sci si flette per effetto di una compressione o di un salto, la talloniera può traslare verso la coda dello sci e ritornare in sede alla fine della sollecitazione, grazie all'effetto dell'ELASTIC RESPONSE SYSTEM®: una molla inserita tra la slitta della talloniera e la vite di regolazione dell'attacco che garantisce 10 o 12 mm di corsa elastica a seconda del modello.

Skis flex when compressed or while jumping, thanks to ELASTIC RESPONSE SYSTEM® the heel piece slides towards the tail and repositions itself once normal conditions are restored.

- Garantisce il flex naturale dello sci, anche in caso di grandi salti/compressioni.
 - Prestazioni di sgancio migliorate in caso di forti sollecitazioni del sistema.
 - Carichi ridotti sul sistema sci-scarpone-attacco.
-
- Safeguards the natural flexibility of skis.
 - Enhanced release mechanism in the event of falls.
 - Reduces the pressure on the ski-boot-binding system.



Un selettore multi-posizione è inserito tra la leva frontale e la base del puntale. Cambiando la posizione del selettore, la durezza di bloccaggio del puntale in modalità di salita varia all'incrementare della pressione sul meccanismo di bloccaggio.

A multi-position selector is inserted between the front lever and the toe lug. By changing the setting of the selector, the stiffness of the toe-lug lock in up-hill mode can be adjusted by increasing pressure on the locking system.



Il primo ski brake da scialpinismo con attivazione automatica. Quando il puntale è bloccato durante la fase di salita, lo SKI BRAKE è pronto a riaprirsi solo in caso di sgancio dello scarpone a seguito di una caduta dopo l'apertura volontaria del puntale.

The first ski brake for ski touring with automatic activation. When the toe part lugs are set on up-hill mode with the front levers, the ski-brake is automatically engaged and allows immediate release in the event of a fall.

- Attivazione automatica.
 - Design innovativo che ottimizza l'ergonomia per ridurre la frizione della neve sul puntale durante la discesa.
-
- Automatic activation.
 - Innovative design that optimizes the ergonomics in order to reduce the snow friction over the toe part while skiing.



Uno speciale design del puntale evita che qualsiasi deposito di neve, ghiaccio o altri detriti si formi al di sotto del meccanismo di blocco del puntale.

A special design of the toe part that avoids any snow/ice/debris build-up under the hooking elements.

- Evita problemi di ghiaccio/bloccaggio del puntale, anche in caso di molteplici ripellaggi.
- Riduce notevolmente l'accumulo di neve nel puntale, garantendo così un'ottima leggerezza in tutte le fasi di utilizzo.
- No snow pack under the toe part, even with several up-hill/downhill transitions.
- Avoids snow loads on the toe part, granting a perfect lightness at any moment.



Un ingegnoso quanto semplice sistema di magneti garantisce la stabilizzazione e gestione degli alzaticchi della talloniera.

An ingenious as simple magnet system provides the handling and stabilization of the heel flaps.

- Sistema estremamente leggero e confortevole per la gestione degli alzaticchi della talloniera.
- Extremely light and comfortable heel flaps system.



Le molle a "U" delle talloniere WORLD CUP di ATK sono realizzate in titanio, materiale che offre un'incredibile leggerezza ma che usurandosi può causare una decisa perdita di prestazioni e sicurezza. Il ROLLING-IN SYSTEM® è una rivoluzione in questo campo: due piccole boccole in acciaio temperato (sezione da 0,4 mm) sono applicate alla parte frontale della molla a "U" per proteggere il Titanio dall'usura.

The U-shaped springs of ATK WORLD CUP heels are made of titanium. This metal provides incredible lightness, but is prone to wear and tear, with possible performance and loss of safety ratio. ROLLING-IN SYSTEM® has revolutionised this field: two small hardened steel bushings (0,4 mm wide) are applied to the front of the U-shaped spring, preventing wear and tear.

- Eliminazione dell'usura, mantenendo l'estrema leggerezza del corpo in titanio.
- Step-in più morbido e sgancio verticale più preciso grazie alle boccole di scorrimento.
- 100% reduction of wear and tear, still granting the extreme lightweight of the titanium body.
- Easier and softer step-in and more stable vertical release thanks to the rolling bushings.



Un sistema straordinariamente innovativo che elimina ogni azione per l'attivazione dello skibrake posteriore. Il meccanismo è settato in maniera completamente automatica e, nel passaggio dalla modalità di salita alla modalità di discesa, lo skibrake si attiva senza la necessità di attività aggiuntive.

An extraordinary innovative system which requires no further action for activating the rear skibrake. The mechanism is automatically set and by switching from ascent to descent mode, the skibrake is activated without any further action.

- Nessuna azione aggiuntiva in fase di attivazione.
- Estrema affidabilità garantita da un numero di componenti limitato.
- Comfort e facilità di utilizzo.
- No additional action required for activation.
- Extreme reliability thanks to a limited number of components.
- Comfort and ease of use.



La regolazione della durezza di sgancio della talloniera, ora disponibile anche nel puntale! Il nuovo puntale ATK Bindings è regolabile nei valori di sgancio e, in combinazione con la talloniera, garantisce un controllo mai visto prima.

The adjustable settings of the heel release are now available for the toe part! The new toe part by ATK Bindings features adjustable release settings and combined with the heel piece it delivers top class stability.

- Massima stabilizzazione ed elasticità dell'attacco.
- Taratura ideale del puntale a seconda delle caratteristiche dello sciatore.
- Performance bilanciata tra puntale e talloniera.
- Exceptional stabilisation and elasticity of bindings.
- Ideal setting of the toe part according to the characteristics of the skier
- Balanced toe part and heel piece performance.



Questo sistema è caratterizzato da una nuova geometria degli elementi di aggancio del puntale. Uno step-in estremamente semplice, immediato e sicuro, disponibile con tutti gli scarponi tech di ultima generazione, anche in caso di soles usurate.

This system is characterised by a new design of the toe part. A smooth step-in which is safe and easy to fit, available on all the latest models and effective even if the soles are worn.

COD. AL09

COD. AL13

FREERIDE SPACER

Mettendo a confronto gli attacchi tech e da sci alpino si può apprezzare come il puntale dei primi sia molto più preciso e rigido rispetto ai secondi. Non si può dire lo stesso per le talloniere, dove la suola scarpa "tech" non preme sullo sci come nell'attacco alpino. Con il nuovo FREERIDE SPACER regolabile abbiamo coperto e superato il gap tra le due tipologie di attacco, garantendo una precisione di sciata superiore a qualsiasi altro modello disponibile sul mercato.

Generally speaking, when comparing Tech with Alpine bindings we realise that the former is sturdier and more precise than the latter. This cannot be said for the heel piece, where the soles of the "Tech" shoes are not fixed to the skis as in the Alpine bindings. With the new adjustable FREERIDE SPACER we filled in the gap between these two bindings and went beyond, providing a superb skiing performance.



AL09 è compatibile con R10, R12, FR14, FR16, FRONT12.

AL09 compatible with R10, R12, FR14, FR16, FRONT12.



AL13 è compatibile con RT8 EVO, RT10 EVO, R11 EVO, R13 EVO, FR15 EVO

AL13 compatible with RT8 EVO, RT10 EVO, R11 EVO, R13 EVO, FR15 EVO



La figura mostra il principio base dello spacer: creare un contatto tra suola scarpa e sci per trasferire direttamente i carichi verticali e torsionali.

The image depicts the basic features of the spacer: connecting the sole of the boot to the ski so as transfer both vertical and torsional loads.

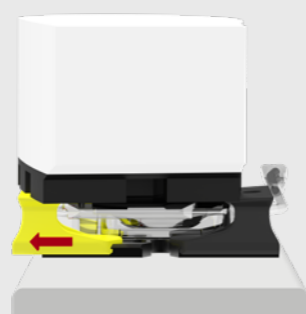

Lo spacer è fornito di 2 "pads" elastici scorrevoli. Questi "pads" garantiscono il mantenimento del valore di sgancio laterale anche quando il sistema è sotto carico (salti o compressioni).

The spacer comes with 2 elastised sliding pads, which allow the right side release value even when jumping.



Lo spacer è fornito di differenti spessori aggiuntivi per personalizzare l'altezza dello spacer e adattarlo ai differenti modelli di suola.

The spacer features different washers for adjusting the length and fit perfectly to any boot sole.

WE ARE ATK

SFIDARE I PROPRI LIMITI

Challenge your limits

Svuotare la mente, uno sci davanti all'altro per godersi i panorami più belli al mondo e tuffarsi in una sciata tra i canali alpini, immersi nella natura selvaggia e fuori da ogni comfort.

Questo è il nostro mood e quello di atleti, ambassadors e Guide Alpine che utilizzano gli attacchi ATK Bindings e fanno parte della nostra grande famiglia: nei loro progetti, nelle spedizioni o semplicemente vivendo la montagna in salita e in discesa, condividono i valori positivi del nostro brand e uno stile di vita outdoor, in perfetta sintonia e nel pieno rispetto della natura.

Gli atleti più forti al mondo, da Axelle Mollaret a Matteo Eydallin, scelgono ATK Bindings per le gare più importanti: l'estrema leggerezza dei nostri attacchi è in grado di garantire le migliori performance, senza sconti su affidabilità e sicurezza. Anche i top skiers come Bruno Compagnet, Tom Leitner, Jackie Paaso, Liv Sansoz e Kristofer Turdell non riescono a resistere alla leggerezza degli attacchi ATK, per vivere a 360° e in totale sicurezza l'esperienza delle discese più remote del pianeta.

Free your mind, enjoy the most beautiful sceneries in the world while skiing and hit the Alpine slopes by immersing yourself into the wild.

This is the message our athletes, ambassadors and Alpine Guides want to convey with their projects, their expeditions or just by climbing up and down mountains, sharing the values of our brand and an outdoor lifestyle in perfect harmony with nature.

The best athletes, such as Axelle Mollaret and Matteo Eydallin, select ATK Bindings for their most important competitions: the lightness of our bindings deliver excellent performance without sacrificing safety and reliability. Top skiers like Bruno Compagnet, Tom Leitner, Jackie Paaso, Liv Sansoz and Kristofer Turdell couldn't resist the lightness of ATK Bindings, which allows them to tackle safely even the remotest slopes in the world.



ATK SIGNATURE EDITIONS

Solo chi ha percorso le salite più impegnative e solcato le discese più ripide può comprendere quanto sia indispensabile utilizzare sulla neve prodotti qualitativamente perfetti, che offrono le migliori performance e garantiscono il massimo livello di sicurezza possibile.

Con il progetto Signature Editions ci siamo spinti ancora oltre e, insieme ai nostri ambassador, tracciamo le linee per sviluppare nuove idee, nuovi gradi di libertà espressiva, nuove combinazioni.

I prodotti Signature Editions rappresentano l'unione perfetta tra l'ingegno tecnologico ATK Bindings e la passione e l'esperienza di chi vive la montagna ogni giorno. Sono la nostra attenzione e dedizione per carpire ogni esigenza più nascosta, di stile e di utilizzo, per offrire prodotti sempre nuovi e all'avanguardia.

Whoever has tackled challenging uphill routes and steep downhill runs knows the importance of quality gear which provides the highest standards of safety and performance.

With the Signature Editions project we decided to go that much further, and with our ambassadors we came up with new ideas, ways of expressing one's own freedom and combinations.

The Signature Editions range blends ATK Bindings' technical engineering with the passion for mountain skiing. We are committed to understanding any need and satisfying any style or use requirement for providing new and cutting-edge products.



ATK BINDINGS 2022 - 2023 COLLECTION

RACE

Le migliori performance per i migliori atleti, sempre pronti ad affrontare le sfide più ardue!

State-of-the-art equipment for the best athletes in the world, always ready to face new challenges!



REVOLUTION WORLD CUP

COD. RV2023

COD. RVLW2023

REVOLUTION WORLD CUP LIGHTWEIGHT

Peso: 105 grammi
Weight: 105 grams

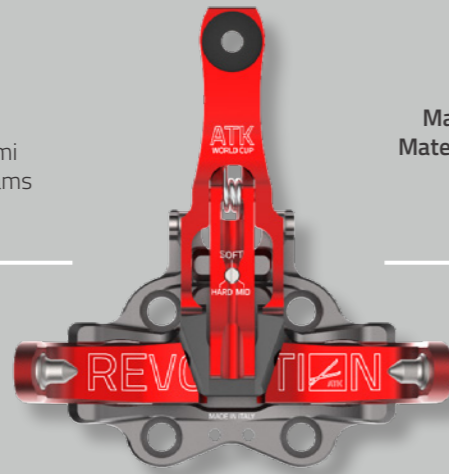

Materiali: Alu 7075, POM, Titanio
Materials: Alu 7075, POM, Titanium

Sgancio verticale/
Vertical release: 9



Sgancio laterale/
Lateral release: 9

105 gr di leggerezza, eleganza ed esclusività.
Un attacco reattivo e facile da usare grazie all'unione
di quattro sistemi brevettati ATK Bindings.

Weighing just 105 gr, these elegant bindings are quick
and easy to use thanks to a combination of 4 patents
by ATK Bindings.

IDEAL
SKIS:



60 - 82mm



< 800 gr



60 - 80Kg

ATK® SYSTEMS



Peso: 105 grammi
Weight: 105 grams

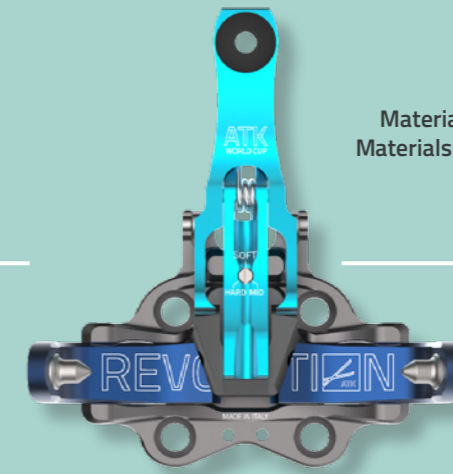

Materiali: Alu 7075, POM, Titanio
Materials: Alu 7075, POM, Titanium

Sgancio verticale/
Vertical release: 6



Sgancio laterale/
Lateral release: 6

La versione lightweight del fratello Revolution World
Cup: semplicità, valori di sgancio ridotti e un design
stiloso anche per gli atleti più leggeri.

The lightweight version of Revolution World Cup.
Simple, with a lower release value and a stylish
design perfect for lighter athletes.

IDEAL
SKIS:



60 - 82mm



< 800 gr



40 - 60Kg

ATK® SYSTEMS



SL WORLD CUP

COD. SL2020

COD. SLLW2020

Peso: 110 grammi
Weight: 110 grams

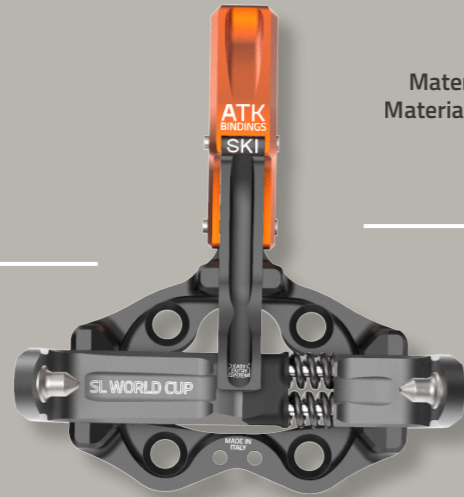

Materiali: Alu 7075, POM, Titanio
Materials: Alu 7075, POM, Titanium

Sgancio verticale/
Vertical release: 9





Sgancio laterale/
Lateral release: 9

Il primo attacco Super Light di ATK Bindings. Linee eleganti, robustezza e valori di sgancio pre-tarati per un utilizzo semplice e preciso. Step in immediato anche in condizioni complicate.

ATK Bindings' first super-light bindings. Elegant lines, strong materials and pre-set release value for an easy yet precise use. Easy step-in in every condition.

IDEAL SKIS:

 60 - 82mm  < 800 gr

 60 - 80Kg

ATK® SYSTEMS



SL WORLD CUP
LIGHTWEIGHT

Peso: 110 grammi
Weight: 110 grams

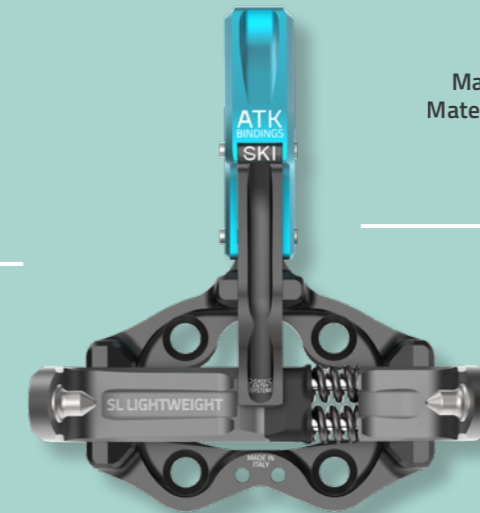

Materiali: Alu 7075, POM, Titanio
Materials: Alu 7075, POM, Titanium

Sgancio verticale/
Vertical release: 6





Sgancio laterale/
Lateral release: 6

La versione lightweight dello storico attacco da gara ATK Bindings. Semplicità, valori di sgancio ridotti e un design stiloso in soli 110 gr: ideale per gli atleti più leggeri.

The lightweight version of ATK Bindings' iconic racing bindings. Simple, with a lower release value and a stylish design weighing 110 gr: ideal for lighter athletes.

IDEAL SKIS:

 60 - 82mm  < 800 gr

 40 - 60Kg

ATK® SYSTEMS



REVOLUTION BRAKE

WORLD
CUP

COD. RVB2023

COD. RVLWB2023

REVOLUTION BRAKE

WORLD
CUP

LIGHTWEIGHT

Peso: 120 grammi
Weight: 120 grams

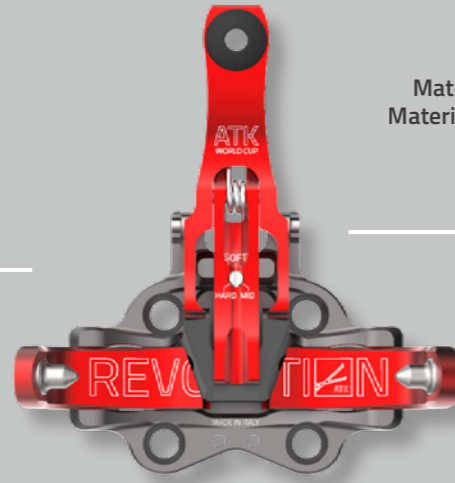

Materiali: Alu 7075, POM, Titanio
Materials: Alu 7075, POM, Titanium

Sgancio verticale/
Vertical release: 9

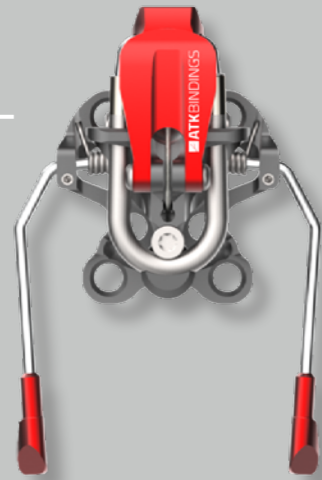

Sgancio laterale /
Lateral release: 9

Skibrake: 70mm

L'attacco da coppa del mondo con ski brake più leggero e performante di sempre, testato e garantito dagli atleti più forti del mondo.

The lightest and most performing World Cup ski brake system ever, tested and endorsed by the world's top athletes.

IDEAL
SKIS:

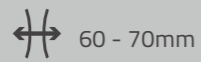

60 - 70mm



< 800 gr



60 - 80Kg

ATK® SYSTEMS



Peso: 120 grammi
Weight: 120 grams

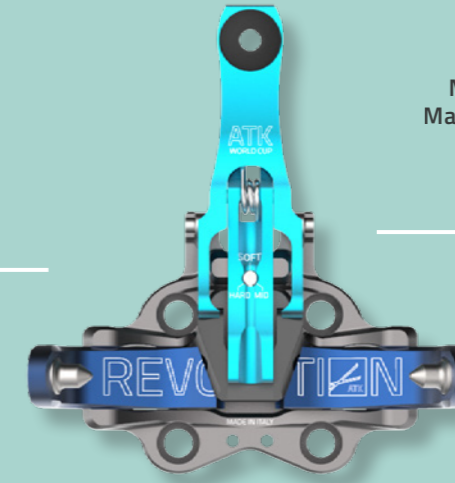

Materiali: Alu 7075, POM, Titanio
Materials: Alu 7075, POM, Titanium

Sgancio verticale/
Vertical release: 6

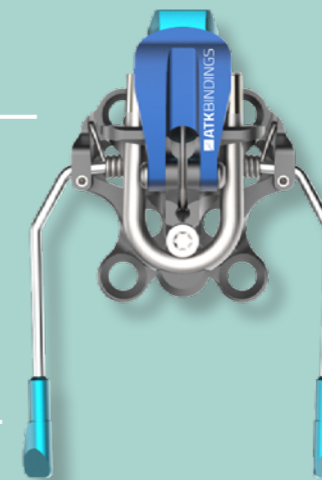

Sgancio laterale /
Lateral release: 6

Skibrake: 70mm

La versione lightweight del fratello Revolution Brake World Cup: nuovo accessorio skibrake integrato, semplicità, valori di sgancio ridotti e un design stiloso anche per gli atleti più leggeri.

The lightweight version of Revolution Brake World Cup with the new ski brake system. Simple, with a lower release value and a stylish design, perfect for lighter athletes.

IDEAL
SKIS:

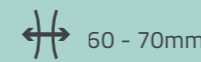

60 - 70mm



< 800 gr



40 - 60Kg

ATK® SYSTEMS



SL BRAKE WORLD CUP

COD. SLB2020

Peso: 130 grammi
Weight: 130 grams

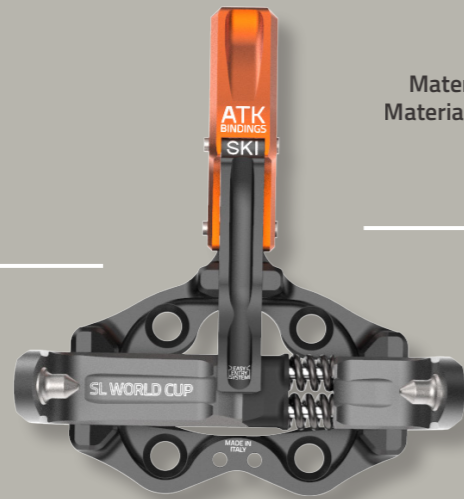

Materiali: Alu 7075, POM, Titanio
Materials: Alu 7075, POM, Titanium

Sgancio verticale/
Vertical release: 9

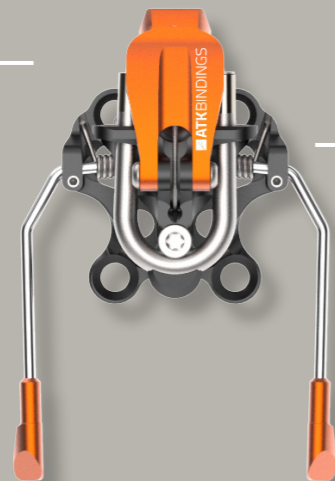

Sgancio laterale/
Lateral release: 9

Skibrake: 70mm

Superleggero, robusto e dal design essenziale, ancora più performante con lo skibrake automatico integrato: modalità di salita e discesa gestite direttamente con la movimentazione dell'alzatacco.

Super-light, robust and with an essential design, even more performing with the automatic ski brake system: ascent and descent modes managed directly with the movement of the heel raiser.

IDEAL SKIS:

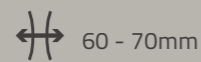

60 - 70mm



< 800 gr



60 - 80Kg

ATK® SYSTEMS

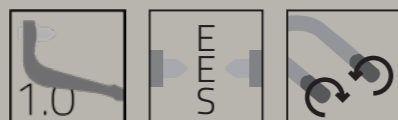

COD. SLLWB2020

SL BRAKE WORLD CUP LIGHTWEIGHT

Peso: 130 grammi
Weight: 130 grams



Materiali: Alu 7075, POM, Titanio
Materials: Alu 7075, POM, Titanium

Sgancio verticale/
Vertical release: 6

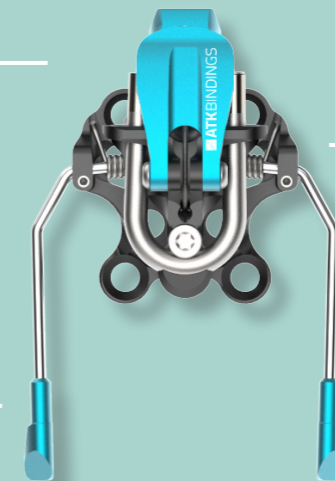

Sgancio laterale/
Lateral release: 6

Skibrake: 70mm

La versione lightweight del fratello SL World Cup Brake con il nuovo accessorio skibrake integrato. Semplicità, valori di sgancio ridotti e un design stiloso anche per gli atleti più leggeri.

The lightweight version of SL World Cup Brake with the new ski brake system. Simple, with a lower release value and a stylish design, perfect for lighter athletes.

IDEAL SKIS:



60 - 70mm



< 800 gr



40 - 60Kg

ATK® SYSTEMS

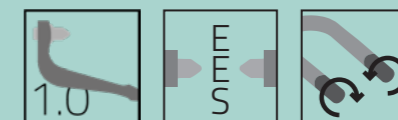

TROFEO BRAKE

COD. PTTRB

Peso: 140 grammi
Weight: 140 grams

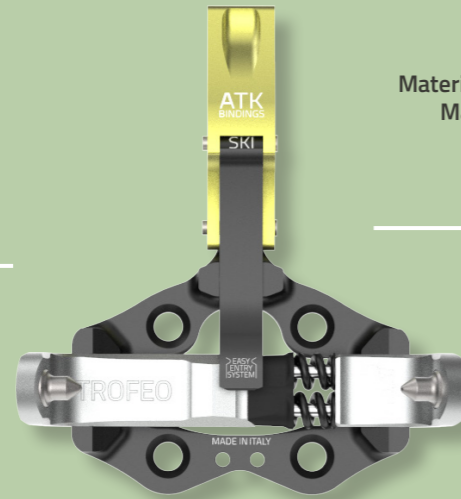

Materiali: Alu 7075, POM, Acciaio inossidabile
Materials: Alu 7075, POM, Stainless steel

Sgancio verticale/
Vertical release: 9

Sgancio laterale/
Lateral release: 9

Skibrake: 70mm

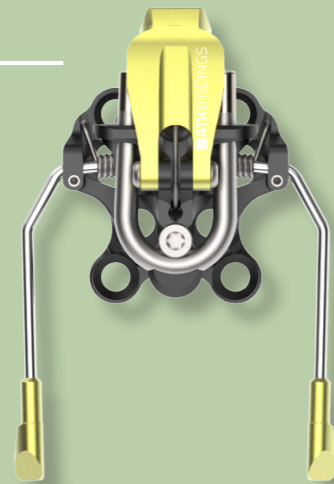

Colma il gap tra attacchi da gara e regolabili. Adatto a giovani sciatori, garisti esperti e scialpinisti: versatile, sicuro e ancora più facile da usare con il nuovo skibrake automatico integrato.

Bindings which fill in the gap between racing and adjustable bindings. Perfect for younger skiers, expert athletes and ski mountaineers: versatile, reliable and even easier to use with the new ski brake system.

IDEAL SKIS:

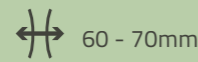

60 - 70mm



< 800 gr



60 - 80Kg

ATK® SYSTEMS

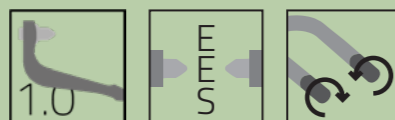

TROFEO BRAKE LIGHTWEIGHT

COD. PTTRLWB

Peso: 140 grammi
Weight: 140 grams

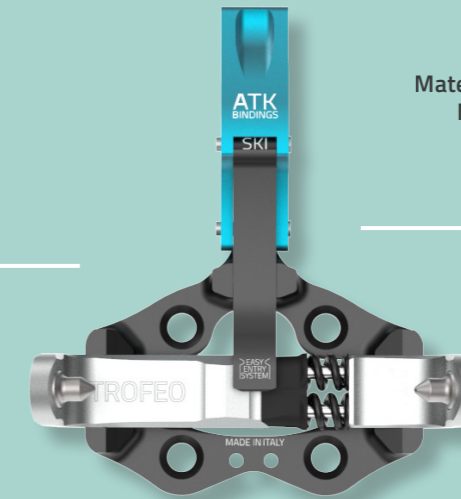

Materiali: Alu 7075, POM, Acciaio inossidabile
Materials: Alu 7075, POM, Stainless steel

Sgancio verticale/
Vertical release: 6

Sgancio laterale/
Lateral release: 6

Skibrake: 70mm

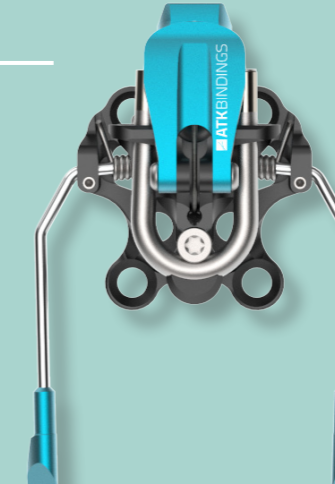

Trofeo Brake in versione lightweight: adatto anche a sciatori più leggeri colma il gap tra attacchi da gara e regolabili. Versatile, sicuro e facile da usare con il nuovo skibrake automatico integrato.

The lightweight version of Trofeo Brake: perfect for lighter athletes, fills in the gap between racing and adjustable bindings. Versatile, reliable and easier to use with the new ski brake system.

IDEAL SKIS:



60 - 70mm



< 800 gr



40 - 60Kg

ATK® SYSTEMS

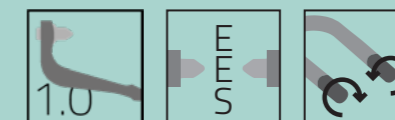

TROFEO

Peso: 145 grammi
Weight: 145 grams

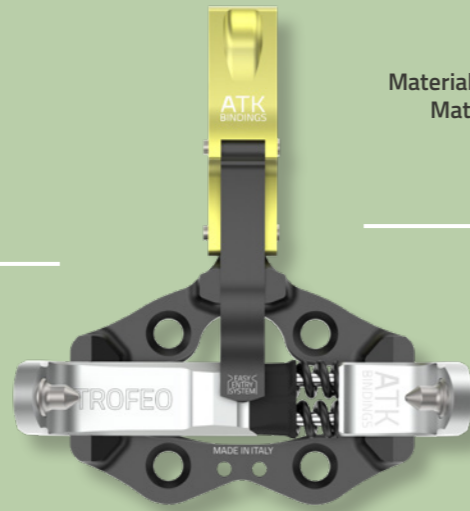

Materiale: Alu 7075, POM, Acciaio inossidabile
Materials: Alu 7075, POM, Stainless steel

Sgancio/Release: 4, 6, 8, 10

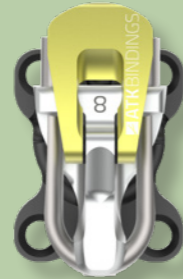

Modalità di camminata/
Walking modes: Flat, +37, +44mm

Un attacco per diverse attività sulla neve, colma il gap tra attacchi da gara e regolabili. Adatto per giovani sciatori, garisti esperti e scialpinisti amanti del ripido alla ricerca di un prodotto versatile e sicuro.

All-purpose bindings which fill in the gap between racing and adjustable bindings. Perfect for younger skiers, expert athletes and ski mountaineers who love steep downhill runs and keep an eye for reliability and versatility.

IDEAL SKIS:



60 - 82mm



< 1000 gr



4: 30 - 45Kg 8: 60 - 75Kg
6: 45 - 60Kg 10: 75 - 90Kg

ATK® SYSTEMS

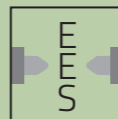

RACE CATEGORY

RECAP

105 Grammi
Grams

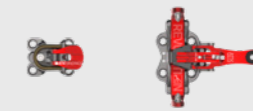

REVOLUTION World Cup

105 Grammi
Grams

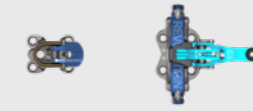

REVOLUTION LIGHTWEIGHT World Cup

110 Grammi
Grams

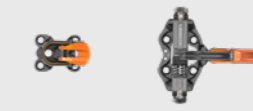

SL World Cup

110 Grammi
Grams

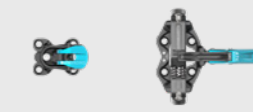

SL LIGHTWEIGHT World Cup

120 Grammi
Grams

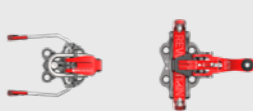

REVOLUTION BRAKE World Cup

120 Grammi
Grams

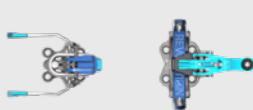

REVOLUTION BRAKE LIGHTWEIGHT World Cup

130 Grammi
Grams

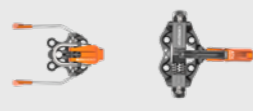

SL BRAKE World Cup

130 Grammi
Grams

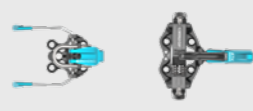

SL BRAKE LIGHTWEIGHT World Cup

140 Grammi
Grams

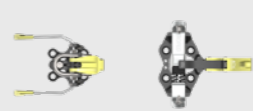

TROFEO BRAKE

140 Grammi
Grams



TROFEO BRAKE LIGHTWEIGHT

145 Grammi
Grams



TROFEO

SPEED TOURING

Solidità, semplicità di utilizzo e affidabilità estrema: nessun limite per solcare le linee più ripide.

Lightness, reliability and versatility to carve the steepest tracks.



TROFEO PLUS

COD. PTTR+

COD. HR8P

Peso: 145 grammi
Weight: 145 grams

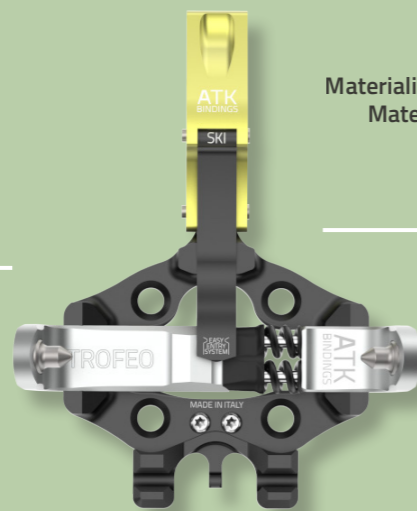

Materiali: Alu 7075, POM, Acciaio inossidabile
Materials: Alu 7075, POM, Stainless steel



Kevlar® Core Leash
Incluso/Included

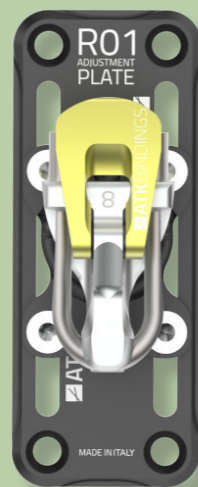

Regolazione/Adjustment: 30mm

Sgancio/Release: 4, 6, 8, 10

Modalità di camminata/
Walking modes: Flat, +43, +49mm

4 Versioni disponibili / 4 Versions available:
Trofeo 4, Trofeo 6, Trofeo 8, Trofeo 10

La versatilità del Trofeo a un livello superiore: leggerezza e solidità strutturale si uniscono per offrire prestazioni ineguagliabili ed eliminare la distanza tra gli sci e le linee più ripide.

The versatility of Trofeo at a higher degree: a strong and light structure for superb performances even on the steepest runs.

IDEAL
SKIS:



60 - 95mm



800 - 1300 gr



4: 30 - 45Kg 8: 60 - 75Kg
6: 45 - 60Kg 10: 75 - 90Kg

ATK® SYSTEMS

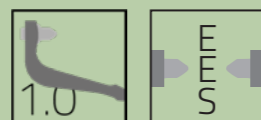

HAUTE ROUTE 8

Peso: 165 grammi
Weight: 165 grams

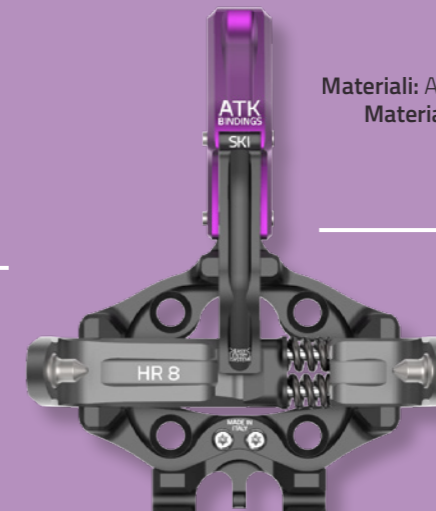

Materiali: Alu 7075, POM, Acciaio inossidabile
Materials: Alu 7075, POM, Stainless steel



Kevlar® Core Leash
Incluso/Included

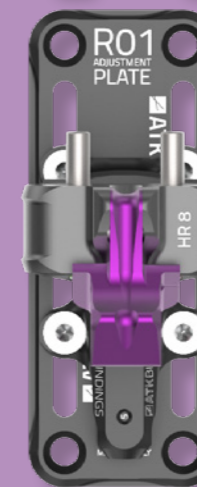

Regolazione/Adjustment: 30mm

Sgancio/Release: 3-8

Modalità di camminata/
Walking modes: Flat, +43, +57mm

Il più leggero sul mercato tra gli attacchi che offrono una regolazione indipendente dei valori di sgancio verticale e laterale. Minimale e senza fronzoli, ora nell'accattivante colorazione purple.

The lightest bindings on the market with adjustable side and vertical release mechanism. Minimalist and straight-forward, now available in captivating purple.

IDEAL
SKIS:



60 - 95mm



800 - 1300 gr



30 - 70Kg

ATK® SYSTEMS

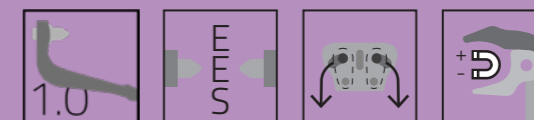

HAUTE ROUTE 10

COD. HR10

COD. KLR9LTP

COD. KLR9LT

KULUAR 9LT

Peso: 165 grammi
Weight: 165 grams

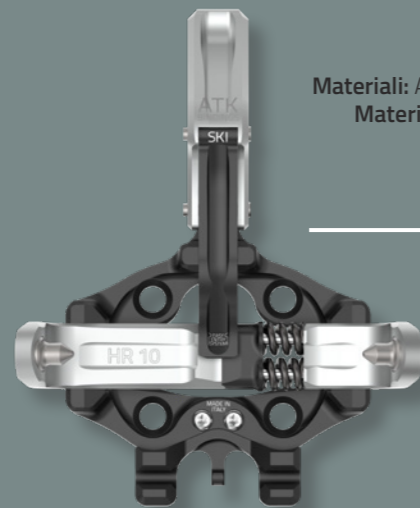

Materiali: Alu 7075, POM, Acciaio inossidabile
Materials: Alu 7075, POM, Stainless steel

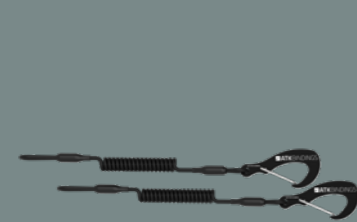

Kevlar® Core Leash
Incluso/Included

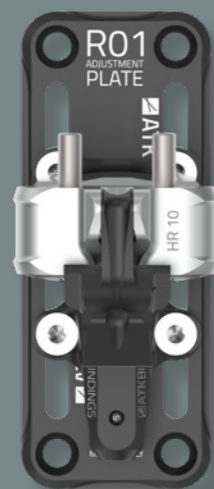

Regolazione/Adjustment: 30mm

Sgancio/Release: 5-10

Modalità di camminata/
Walking modes: Flat, +43, +57mm

Il più leggero sul mercato tra gli attacchi che offrono una regolazione indipendente dei valori di sgancio verticale e laterale, nella stessa colorazione vincente di sempre. Minimale e senza fronzoli, ideale per gli utilizzatori più esperti sulle alte vie della Alpi.

The lightest bindings on the market with adjustable side and vertical release mechanism, in the same enticing colour. Minimalist and straight-forward, ideal for expert ski mountaineers.

IDEAL SKIS:



60 - 95mm



800 - 1300 gr



50 - 90Kg

ATK® SYSTEMS



Peso: 200 grammi
Weight: 200 grams

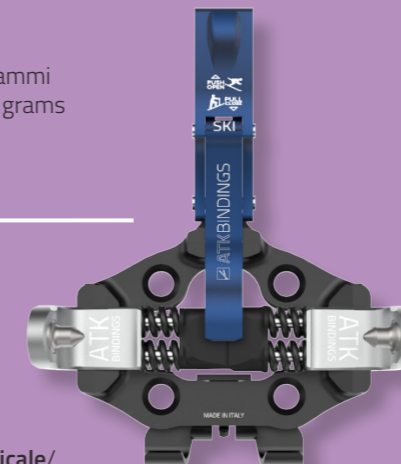

Sgancio verticale/
Vertical release: Soft



Kevlar® Core Leash
Incluso/Included



Materiali: Alu 7075, POM,
Acciaio inossidabile
Materials: Alu 7075, POM,
Stainless steel

Sgancio laterale/
Lateral release: 4-9

Modalità di camminata/Walking
modes: Flat, +29, +30, +43mm

Regolazione/
Adjustment: 20mm

Un design innovativo ed essenziale nelle accattivanti colorazioni blue e purple. La perfetta combinazione tra le caratteristiche tipiche del Trofeo e la flessibilità di regolazione dello sgancio laterale della linea Touring.

An essential, innovative yet sturdy design in captivating blue and purple. Combining the features of Trofeo with the flexibility of the Touring range with its adjustable side release.

IDEAL SKIS:



75 - 102mm



800 - 1500 gr



30 - 70Kg

ATK® SYSTEMS

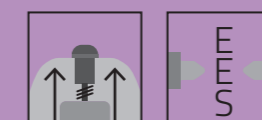

KULUAR 12LT

Peso: 200 grammi
Weight: 200 grams

Materiali: Alu 7075, POM, Acciaio inossidabile
Materials: Alu 7075, POM, Stainless steel

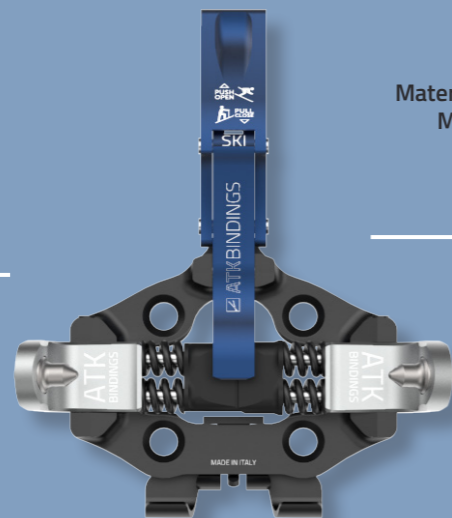

Sgancio verticale/
Vertical release: Hard

Sgancio laterale/
Lateral release: 6-12

Modalità di camminata/
Walking modes:
Flat, +29, +30, +43mm

Regolazione/
Adjustment: 20mm



Speed kit incluso/
Speed kit included: + 59 grams

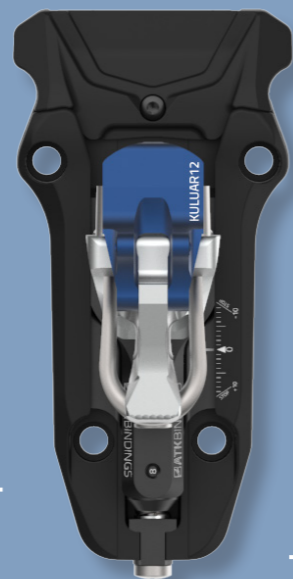

Un design innovativo, essenziale e visivamente materico nella stessa colorazione vincente di sempre. La perfetta combinazione tra le caratteristiche tipiche del Trofeo e la flessibilità di regolazione dello sgancio laterale della linea Touring.

An essential, innovative yet sturdy design in the same enticing colour. Combining the features of Trofeo with the flexibility of the Touring range with its adjustable side release.

IDEAL SKIS:



75 - 102mm



800 - 1500 gr



50 - 90Kg

ATK® SYSTEMS

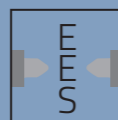

SPEED TOURING CATEGORY

RECAP

145*
Grammi
Grams

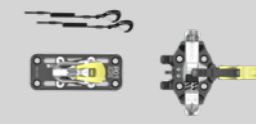

TROFEO PLUS 4-6-8-10 (* +59gr Speed Kit)

165*
Grammi
Grams

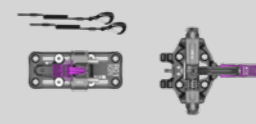

HAUTE ROUTE 8 (* +59gr Speed Kit)

165*
Grammi
Grams



HAUTE ROUTE 10 (* +59gr Speed Kit)

200
Grammi
Grams



KULUAR 9LT

200
Grammi
Grams

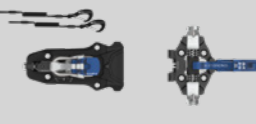

KULUAR 12LT

TOURING

**Semplici, funzionali e affidabili
in ogni condizione: un connubio
perfetto per esperienze a fil di
cielo.**

Simplicity, functionality and
reliability are the hallmarks of
ATK touring bindings:
the sky's the limit.



KULUAR 12 BRAKE

COD. KLR12BR.XXX

Peso: 250 grammi
Weight: 250 grams

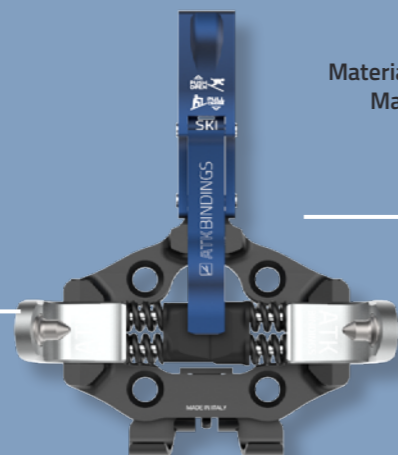

Materiali: Alu 7075, POM, Acciaio inossidabile
Materials: Alu 7075, POM, Stainless steel

Sgancio verticale/
Vertical release: Hard

Sgancio laterale/
Lateral release: 6-12

Skibrake:
75, 86, 91, 97, 102mm

Modalità di camminata/
Walking modes:
Flat, +29, +30, +43mm

Elasticità talloniera/
Heel elastic travel: 10mm (E.R.S)

Regolazione/
Adjustment: 20mm

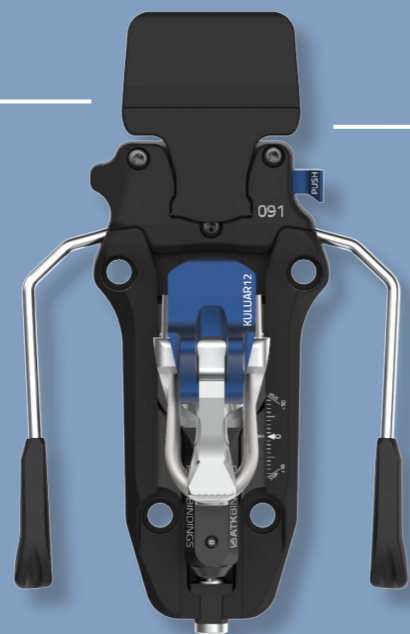

Leggerezza, semplicità e immediatezza con un approccio più allround rispetto al compagno LT. Un puntale simile alla linea CREST lo rende estremamente solido e molto facile da utilizzare.

Lightness and simplicity, a more all-round approach compared to the LT version. A toe piece similar to that of the CREST range makes it extremely robust and easy to use.

IDEAL SKIS:



75 - 102mm



800 - 1500 gr



50 - 90Kg

ATK® SYSTEMS

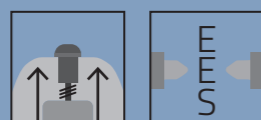

COD. KLR9BRP.XXX

COD. KLR9BR.XXX

KULUAR 9 BRAKE

Peso: 250 grammi
Weight: 250 grams



Materiali: Alu 7075, POM,
Acciaio inossidabile
Materials: Alu 7075, POM,
Stainless steel

Sgancio verticale/
Vertical release: Soft

Sgancio laterale/
Lateral release: 4-9

Skibrake:
75, 86, 91, 97, 102mm

Modalità di camminata/
Walking modes:
Flat, +29, +30, +43mm

Elasticità talloniera/
Heel elastic travel:
10mm (E.R.S)

Regolazione/
Adjustment: 20mm

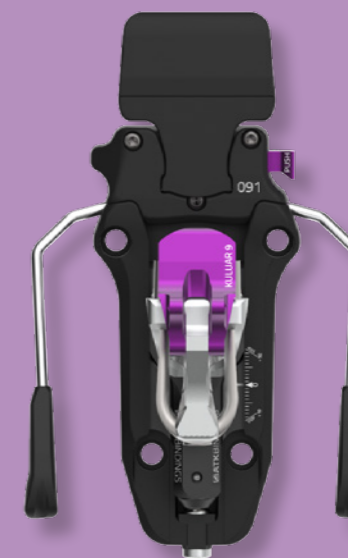
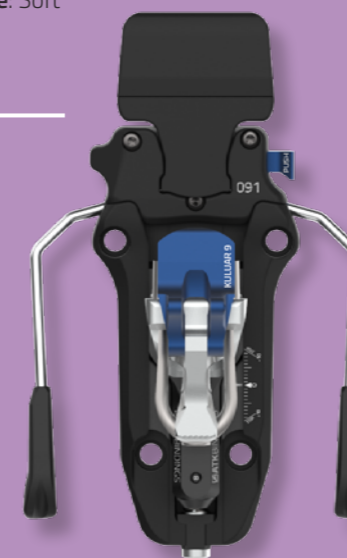

Leggerezza, semplicità e immediatezza nelle accattivanti colorazioni blue e purple. Approccio più allround rispetto al compagno LT e puntale simile alla linea CREST lo rendono estremamente solido e molto facile da utilizzare.

Lightness and simplicity in captivating blue and purple. A more all-round approach compared to the LT version and a toe piece similar to that of the CREST range makes it extremely robust and easy to use.

IDEAL SKIS:



75 - 102mm



800 - 1500 gr



30 - 70Kg

ATK® SYSTEMS

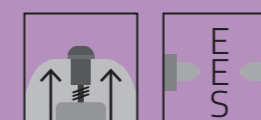

RT10 EVO

Peso: 280 grammi
Weight: 280 grams

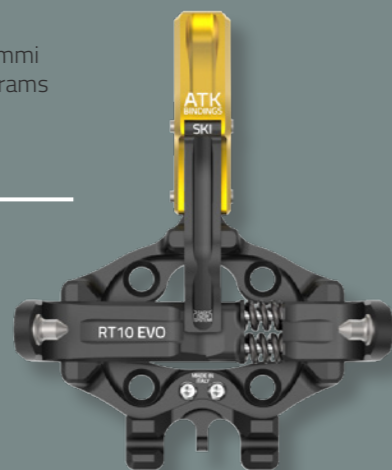

Materiali: Alu 7075, POM,
Acciaio inossidabile
Materials: Alu 7075, POM,
Stainless steel

Sgancio/Release: 5-10

Ski brake:
86, 91, 97, 102mm

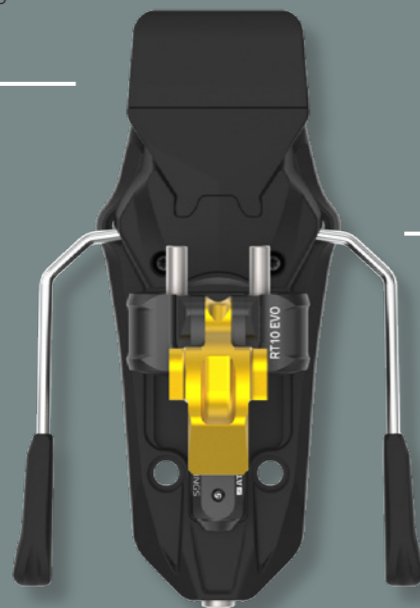

Regolazione/
Adjustment: 20mm

Modalità di camminata/
Walking modes: Flat, +35, +48mm



!NEW!
AUTOBRAKE
SYSTEM

Funzionalità premium e ottime performance per un confort di utilizzo unico. Un puntale semplice in stile RACE, con una talloniera dal design rinnovato e un nuovo sistema di ski brake automatico.

Functional and high performances providing excellent comfort. A simple RACE-style toe part with a redesigned heel piece and a new automatic ski-break system.

IDEAL
SKIS:



80 - 102mm



800 - 1500 gr



50 - 90Kg

ATK® SYSTEMS

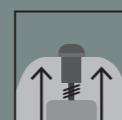
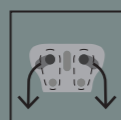

RT8 EVO

COD.RT8EVP.XXX

Peso: 280 grammi
Weight: 280 grams

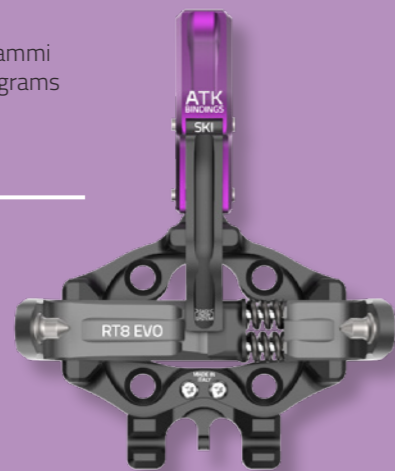

Materiali: Alu 7075, POM,
Acciaio inossidabile
Materials: Alu 7075, POM,
Stainless steel

Sgancio/Release: 3-8

Skibrake:
86, 91, 97, 102mm

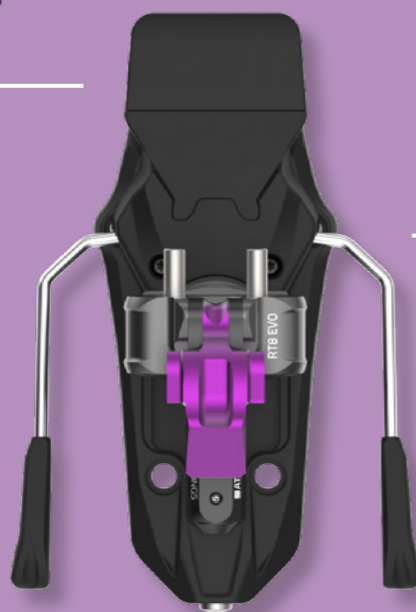

Regolazione/
Adjustment: 20mm

Modalità di camminata/
Walking modes: Flat, +35, +48mm

La versione lightweight del modello RT10 EVO, con valori di sgancio più adatti agli sciatori leggeri. Stesse funzionalità, stessa semplicità di utilizzo e un design rinnovato unico e riconoscibile.

The lightweight version of model RT10 EVO with a lower release value. Same features and easy to use featuring a renewed and recognisable design.

INNOVATIVE
AUTOBRAKE
SYSTEM

IDEAL
SKIS:



80 - 102mm



800 - 1500 gr



30 - 70Kg

ATK® SYSTEMS



CREST 10

COD.CR10DB.XXX

COD.CR10.XXX

Peso: 280 grammi
Weight: 280 grams



Materiali: Alu 7075, POM,
Acciaio inossidabile
Materials: Alu 7075, POM,
Stainless steel

Sgancio/
Release: 5-10

Skibrake:
75, 86, 91, 97,
102, 108mm

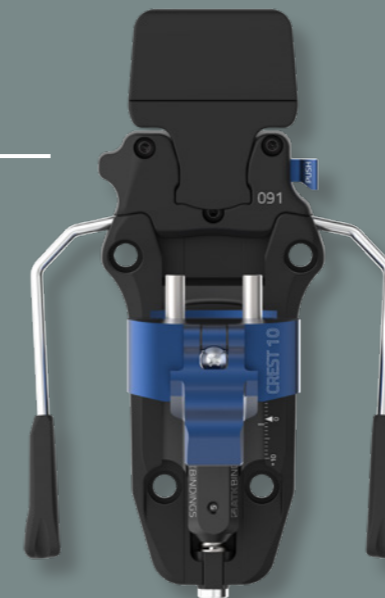

Elasticità talloniera/
Heel elastic travel:
10mm (E.R.S)

Modalità di camminata/
Walking modes:
Flat, +27, +42mm

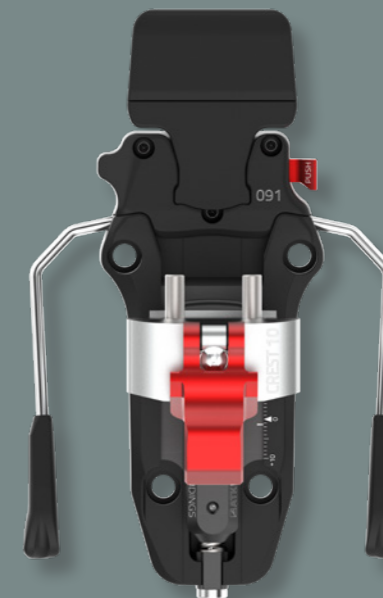

Affidabile e leggero per lunghe escursioni, dalle creste più alte alle discese più estreme: completo e semplice al tempo stesso, con una talloniera dalle caratteristiche uniche.

Light and reliable for the long days in the backcountry, from the highest mountain tops to extreme downhill runs: simple yet complete, the heel piece features unique characteristics.

IDEAL
SKIS:



75 - 108mm



800 - 1500 gr



50 - 90Kg

ATK® SYSTEMS

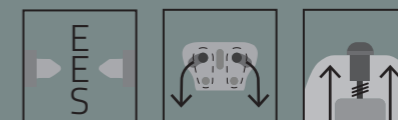

CREST 8

COD. CR8P.XXX

COD. CR8.XXX

Peso: 280 grammi
Weight: 280 grams

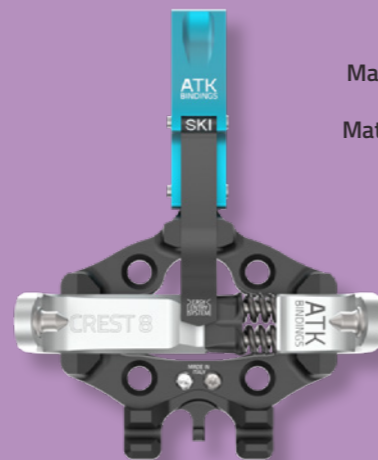
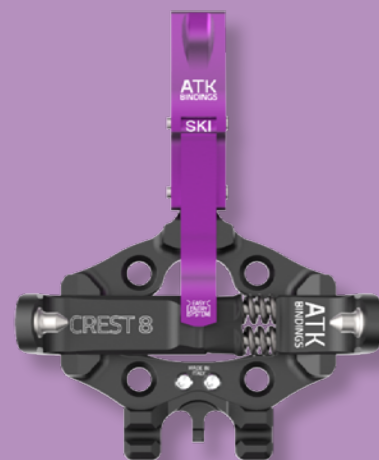

Materiali: Alu 7075, POM,
Acciaio inossidabile
Materials: Alu 7075, POM,
Stainless steel

Sgancio/
Release: 3-8

Skibrake:
75, 86, 91, 97,
102, 108mm

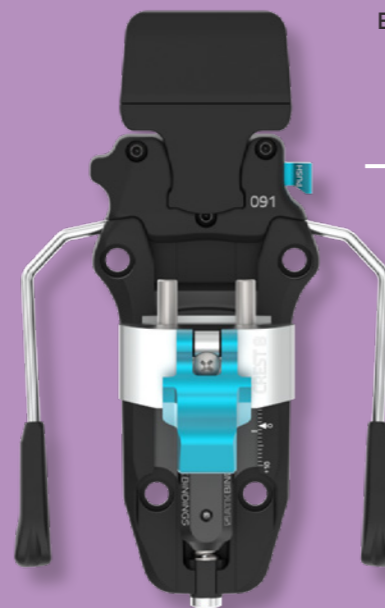
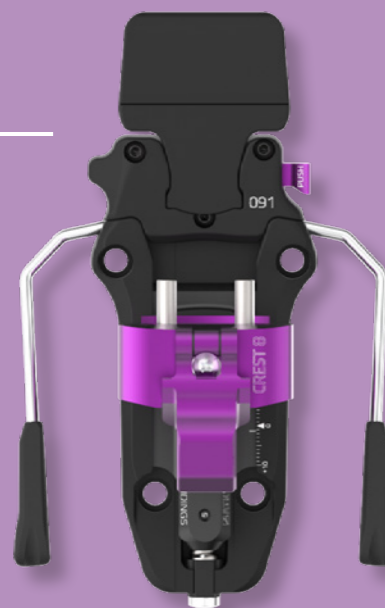

Elasticità talloniera/
Heel elastic travel:
10mm (E.R.S)

Modalità di camminata/
Walking modes:
Flat, +27, +42mm

La versione lightweight di Crest 10, dedicata agli utenti più leggeri e ai principianti del mondo dello scialpinismo. Estrema leggerezza, solidità strutturale, versatilità, sicurezza e precisione.

The lightweight version of Crest 10, dedicated to lighter ski mountaineers and beginners. Extremely light and robust, these bindings are versatile and reliable.

IDEAL
SKIS:



75 - 108mm



800 - 1500 gr



30 - 70Kg

ATK® SYSTEMS

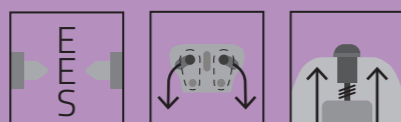

COD. XCND5.XXX

CANDY 5

Peso: 290 grammi
Weight: 290 grams

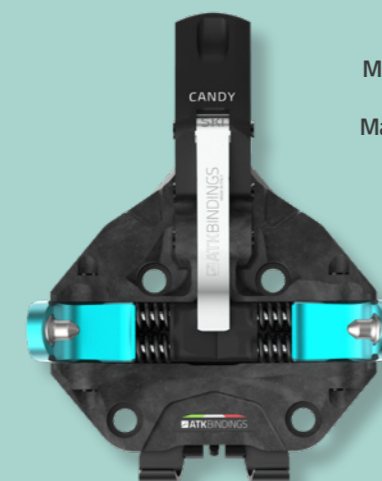

Materiali: Alu 7075, POM, Acciaio inossidabile,
Composito di fibra di vetro caricato al 30%
Materials: Alu 7075, POM, Stainless steel, 30%
Glass fiber composite

Sgancio/
Release: 1.5-5

Skibrake:
75, 86, 91, 97, 102mm

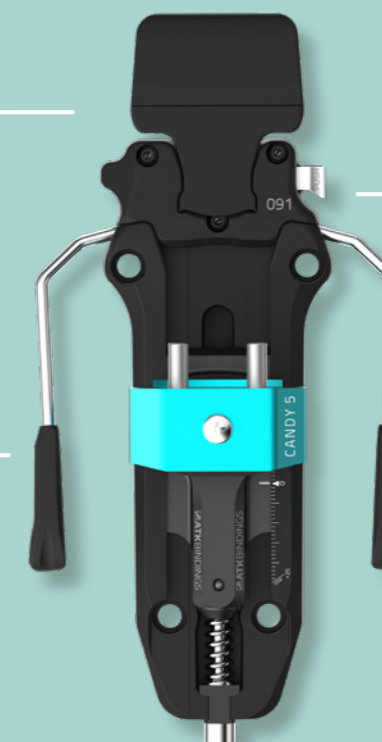

Elasticità talloniera/
Heel elastic travel : 10mm (E.R.S)

Modalità di camminata/
Walking modes: Flat, +32mm

L'impegno di ATK Bindings per futuri sci alpinisti con grandi aspirazioni: studiato nei minimi dettagli per pesi ultra leggeri, è un'ingegnosa combinazione tra solidità, maneggevolezza ed intuitività.

ATK Bindings' craftsmanship at the disposal of future ski mountaineers with big aspirations: designed for ultra-low weights, an ingenious combination of robustness and easier handling.

IDEAL
SKIS:



75 - 102mm



800 - 1500 gr



25 - 40Kg

ATK® SYSTEMS

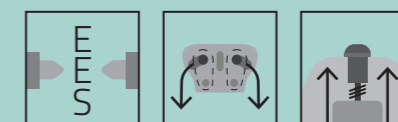

FRONT 9

Peso: 320 grammi
Weight: 320 grams

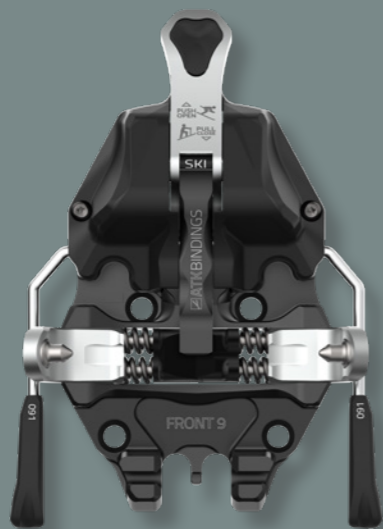

Materiali: Alu 7075, POM,
Acciaio inossidabile
Materials: Alu 7075, POM,
Stainless steel

Ski brake:
86, 91, 97, 102, 108mm

Sgancio/
Release: 4-9



Elasticità talloniera/
Heel elastic travel:
10mm (E.R.S)

Modalità di camminata/
Walking modes:
Flat, +26, +40mm

Il rivoluzionario ski brake frontale, in un attacco per scialpinisti leggeri: valori di sgancio più bassi del Front 12 e molle più morbide nel meccanismo di bloccaggio del puntale.

The revolutionary front ski-brake for light ski mountaineers: lower release value and softer springs in the toe piece locker mechanism compared to Front 12.

IDEAL
SKIS:



80 - 108mm



1000 - 1500 gr



30 - 70Kg

ATK® SYSTEMS



TOURING CATEGORY

RECAP

250 Grammi
Grams

KULUAR 9 BRAKE

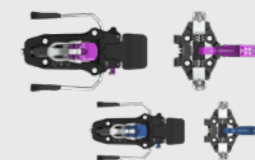

250 Grammi
Grams

KULUAR 12 BRAKE



280 Grammi
Grams

RT 8 EVO



280 Grammi
Grams

RT 10 EVO



280 Grammi
Grams

CREST 8

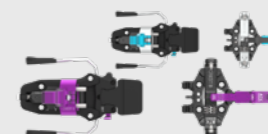

280 Grammi
Grams

CREST 10

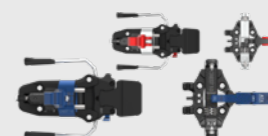

290 Grammi
Grams

CANDY 5

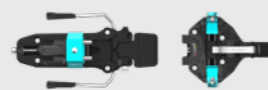

320 Grammi
Grams

FRONT 9



FREE TOURING

**Divertimento in discesa
senza alcun compromesso:
design essenziale e facilità
d'uso anche in condizioni
estreme.**

Enjoy downhill skiing without
compromise: essential
design and simple to use
even in extreme conditions.



C-RAIDER 12

COD. XC-R12.XXX

Peso: 305 grammi
Weight: 305 grams



Materiali: Alu 7075, POM, Acciaio inossidabile, Composito di carbonio caricato al 30%
Materials: Alu 7075, POM, Stainless steel, 30% Carbon fiber composite

Sgancio/
Release: 5-12

Skibrake:
86, 91, 97, 102,
108, 120mm

Elasticità talloniera/
Heel elastic travel:
12mm (E.R.S)

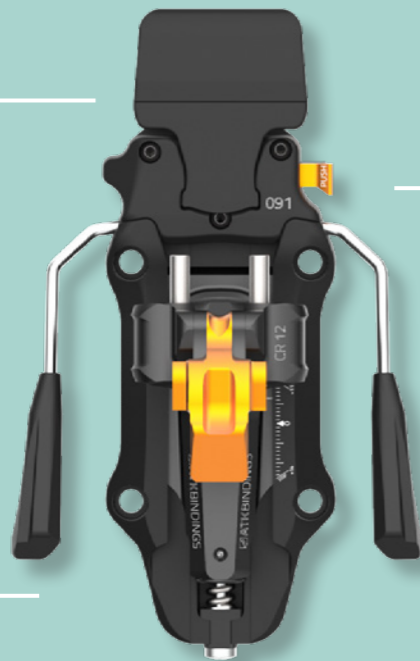

Regolazione/
Adjustment: 25mm

Modalità di camminata/
Walking modes:
Flat, +32, +37, +46, +52mm

Un peso record di soli 305 grammi con un puntale composito in fibra di carbonio: completa la gamma Free Touring garantendo prestazioni ai massimi livelli.

Weighing a record 305 gr with carbon fibre composite toe piece: completing the Free Touring range and providing top quality performance.

IDEAL SKIS: 80 - 120mm 1000 - 1700 gr 50 - 100Kg

ATK® SYSTEMS



C-RAIDER 10

COD. XC-R10P.XXX

COD. XC-R10.XXX

Peso: 305 grammi
Weight: 305 grams

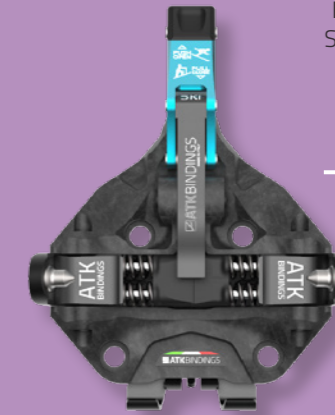

Materiali: Alu 7075, POM, Acciaio inossidabile, Composito di carbonio caricato al 30%
Materials: Alu 7075, POM, Stainless steel, 30% Carbon fiber composite

Sgancio/
Release: 4-10

Skibrake:
86, 91, 97, 102,
108, 120mm

Elasticità talloniera/
Heel elastic travel:
12mm (E.R.S)

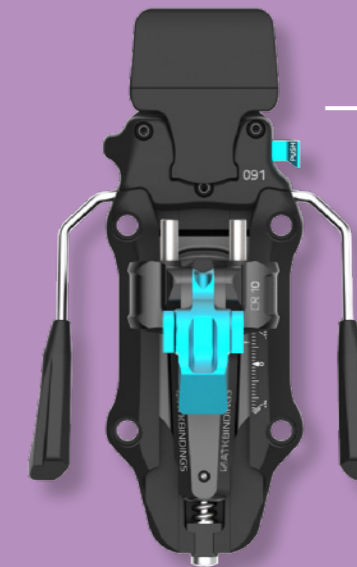
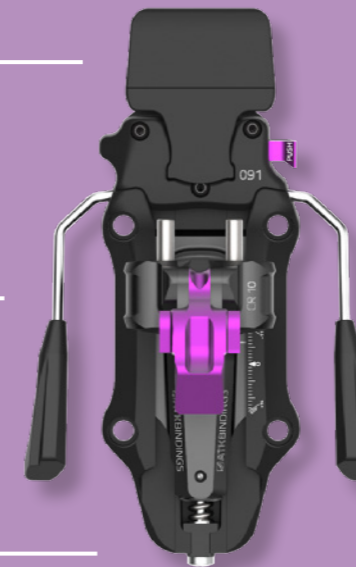

Regolazione/
Adjustment: 25mm

Modalità di camminata/
Walking modes:
Flat, +32, +37, +46, +52mm

Perfetto per i free-tourer più leggeri. Stesse caratteristiche tecniche del C-Raider 12 ma range di sgancio inferiore e un peso record grazie al puntale composito in fibra di carbonio.

Perfect for lighter free-touring skiers. Same technical features of C-Raider 12, with a lower release value and a record weight thanks to the carbon fibre composite toe part.

IDEAL SKIS: 80 - 120mm 1000 - 1700 gr 40 - 80Kg

ATK® SYSTEMS



RAIDER 12

- COD. R12B.XXX
- COD. R12W.XXX
- COD. R12DB.XXX
- COD. R12G.XXX

Peso: 335 grammi
Weight: 335 grams

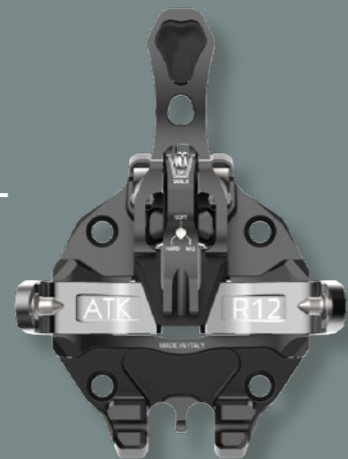

Materiali: Alu 7075, POM, Acciaio inossidabile
Materials: Alu 7075, POM, Stainless steel

Sgancio/
Release: 5-12

Skibrake:
86, 91, 97, 102,
108, 120mm

Elasticità talloniera/
Heel elastic travel:
12mm (E.R.S)

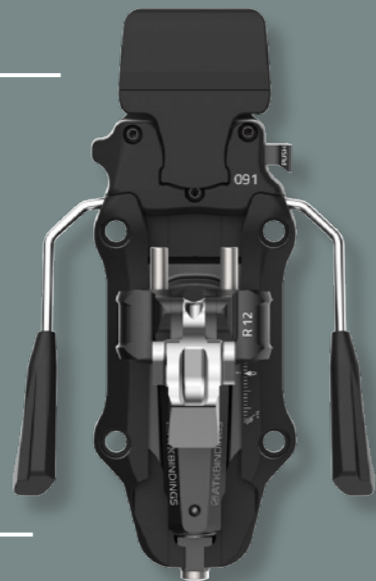

Regolazione/
Adjustment: 25mm

Modalità di camminata/
Walking modes:
Flat, +32, +37, +46, +52mm



La performance prima di tutto: 4 tecnologie innovative e 6 brevetti ATK in un attacco di soli 335 grammi per il vero gioiello della categoria Free Touring.

Performance first: 4 innovative systems 6 ATK patents, all of this in bindings weighing just 335 gr. Our jewel item from the Free Touring range.

IDEAL SKIS:

80 - 120mm 1000 - 1700 gr 50 - 100Kg

ATK® SYSTEMS



RAIDER 12

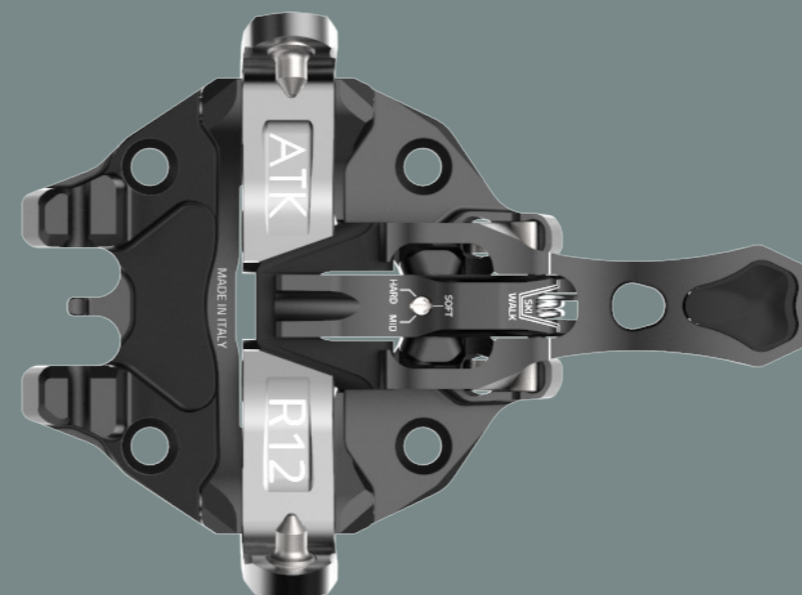

Colore: Bianco
Colorway: White

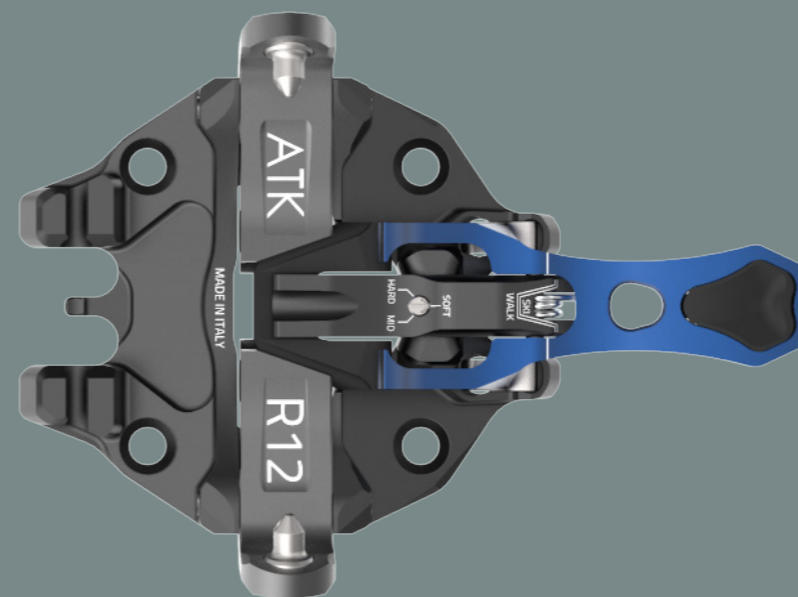

Colore: Arancione
Colorway: Orange



Colore: Nero/Titanio
Colorway: Black/Titanium



Colore: Blu/Titanio
Colorway: Darkblue/Titanium

RAIDER 10

● COD. R10.XXX
● COD. R10P.XXX

Peso: 335 grammi
Weight: 335 grams

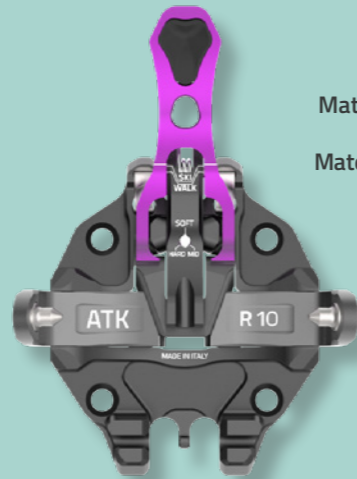
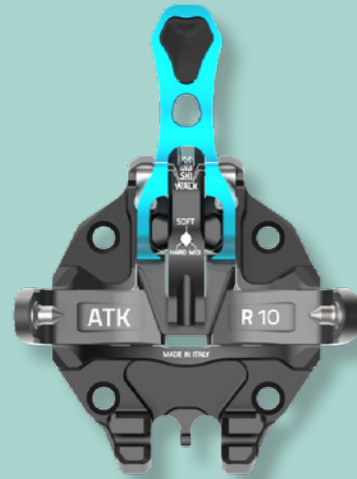

Materiali: Alu 7075, POM,
Acciaio inossidabile
Materials: Alu 7075, POM,
Stainless steel

Skibrake:
86, 91, 97, 102,
108, 120mm

Sgancio/
Release: 4-10

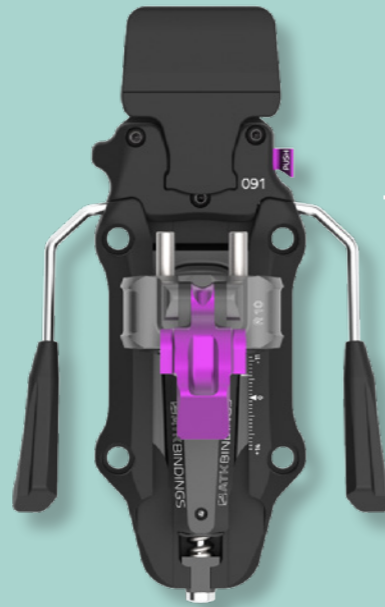
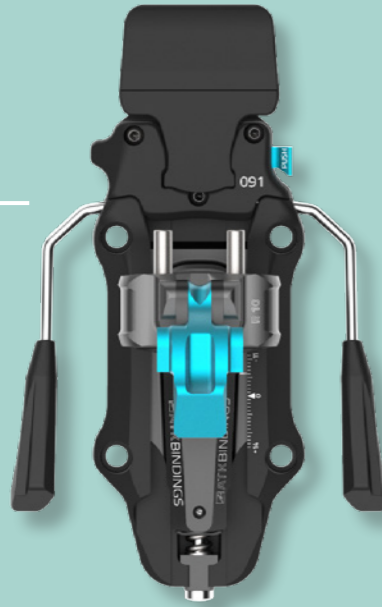

Elasticità talloniera/
Heel elastic travel:
10mm (E.R.S)

Modalità di camminata/
Walking modes:
Flat, +32, +37, +46, +52mm

La famiglia Raider si arricchisce con una versione dedicata ai free-tourer più leggeri. Design stiloso e stesse caratteristiche tecniche del Raider 12, ma con un range di sgancio inferiore.

The Raider range adds a dedicated version for lighter free-tourers. Stylish design and the same features of Raider 12, with a lower release value.

IDEAL SKIS: 80 - 120mm 1000 - 1700 gr 40 - 80Kg

ATK® SYSTEMS



FREERAIDER 14

● COD. FR14Y.XXX

Peso: 360 grammi
Weight: 360 grams

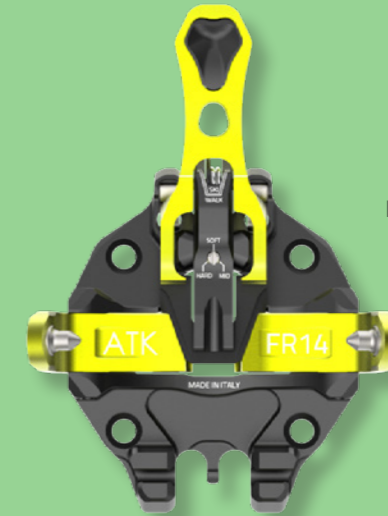

Materiali: Alu 7075, POM, Acciaio inossidabile
Materials: Alu 7075, POM, Stainless steel

Sgancio/
Release: 8-14

Skibrake:
97, 102, 108, 120mm

Elasticità talloniera/
Heel elastic travel:
12mm (E.R.S)

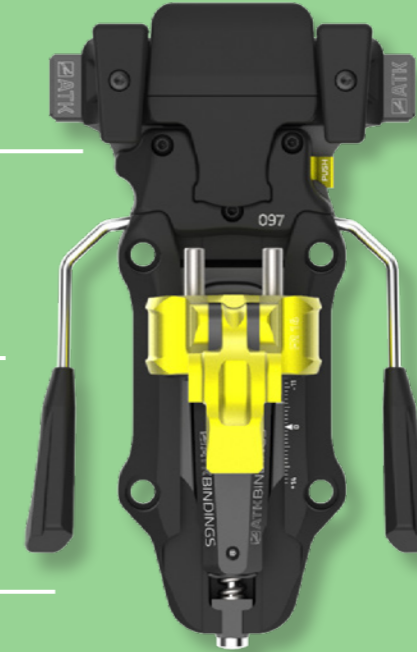

Regolazione/
Adjustment: 25mm

Modalità di camminata/
Walking modes:
Flat, +32, +37, +46, +52mm

Freeride Spacer AL09 incluso
AL09 Freeride Spacer included

La nuova era degli attacchi pin: FR14 minimizza il peso massimizzando stabilità e sicurezza, offrendo vere e proprie sensazioni alpine con soli 360 grammi di peso.

The new era of pin bindings is here: FR14 minimizes weight by maximizing stability, safety and reliability providing authentic ski mountaineering experiences at just 360 gr.

IDEAL SKIS: 97 - 120mm 1000 - 1700 gr 70 - 110Kg

ATK® SYSTEMS

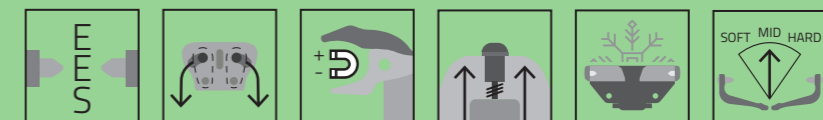

2022 RAIDER EVO COLLECTION

Tutto lo spirito RAIDER nell'ultima frontiera del Free Touring!
The spirit of RAIDER for the last frontier of Free Touring!

La gamma RAIDER EVO si rinnova per dar vita ad una serie di attacchi che rappresentano la massima espressione tecnologica di ATK Bindings applicata alla categoria Free Touring. Raider 11 Evo, Raider 13 Evo e Freeraider 15 Evo non sono semplici attacchi, sono opere di scultura ottenute dal sapere e dall'esperienza tecnica ATK Bindings: un design futuristico e senza precedenti, per performance inarrivabili.

La prima grande novità consiste nella talloniera dotata di ski brake automatico che va a sostituire il precedente azionamento a pulsante tramite la rotazione della testa della talloniera. La seconda risiede in un puntale rivoluzionario totalmente regolabile nei valori di sgancio che permette all'utilizzatore di ottenere un perfetto adattamento alle proprie caratteristiche di sciata.

The RAIDER EVO range is completely redesigned and features a new series of bindings which display the best of ATK Bindings' technology applied to the Free Touring category. Raider 11 Evo, Raider 13 Evo and Freeraider 15 Evo are not just bindings, they are a work of art by ATK Bindings: a futuristic design for outstanding performances.

The main novelty is the heel piece which is fitted with an automatic ski brake and replaces the manual push button mechanism, now activated by rotating the head of the heel piece. The second, is the revolutionary toe piece which features adjustable release values and provides perfect adaptability to one's own style of skiing.



RAIDER 11 EVO

COD. R11P.XXX



Peso: 370 grammi
Weight: 370 grams

Materiali: Alu 7075, POM, Acciaio inossidabile
Materials: Alu 7075, POM, Stainless steel

**Sgancio puntale/
Toe part Release:** 3-11

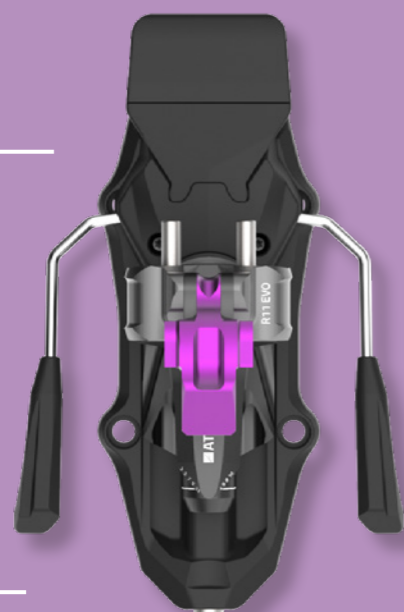

**Sgancio talloniera/
Heel part Release:** 3-11

**Regolazione/
Adjustment:** 25mm

Skibrake:
86, 91, 97,
102, 108, 120mm

**Modalità di camminata/
Walking modes:**
Flat, +35, +49mm

**Elasticità talloniera/
Heel elastic travel:**
14mm (E.R.S)

NEW!
AUTOBRAKE
SYSTEM

Un concentrato di novità nell'accattivante colorazione purple. Nuova talloniera con ski brake automatico e un rivoluzionario puntale totalmente regolabile nei valori di sgancio.

Brand new features in captivating purple. A new heel piece with automatic ski-brake and improved toe piece featuring adjustable side release tension.

**IDEAL
SKIS:**

80 - 120mm

1000 - 1700 gr

40 - 90Kg

ATK® SYSTEMS

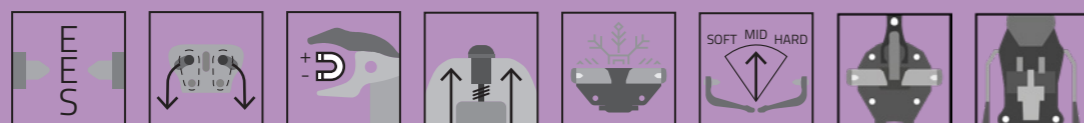

RAIDER 13 EVO

COD. R13W.XXX



Peso: 370 grammi
Weight: 370 grams

Materiali: Alu 7075, POM, Acciaio inossidabile
Materials: Alu 7075, POM, Stainless steel

**Sgancio puntale/
Toe part Release:** 5-13

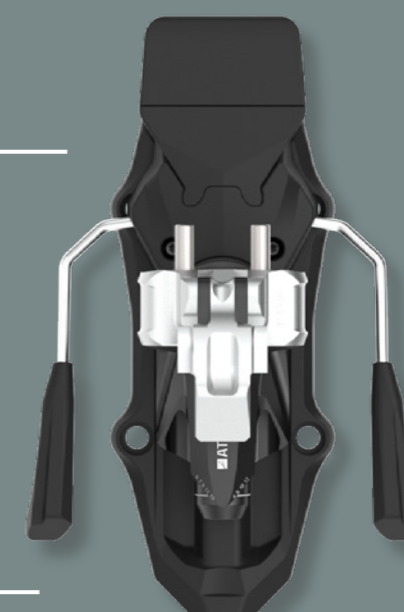

**Sgancio talloniera/
Heel part Release:** 5-13

**Regolazione/
Adjustment:** 25mm

Skibrake:
86, 91, 97,
102, 108, 120mm

**Modalità di camminata/
Walking modes:**
Flat, +35, +49mm

**Elasticità talloniera/
Heel elastic travel:**
14mm (E.R.S)

NEW!
AUTOBRAKE
SYSTEM

Il nuovo Raider 13 Evo nella versione white con talloniera dotata di ski brake automatico e un puntale rivoluzionario totalmente regolabile nei valori di sgancio.

The new Raider 13 Evo in its white version features automatic ski brake and enhanced toe piece with adjustable release settings on both sides.

**IDEAL
SKIS:**

80 - 120mm

1000 - 1700 gr

50 - 110Kg

ATK® SYSTEMS

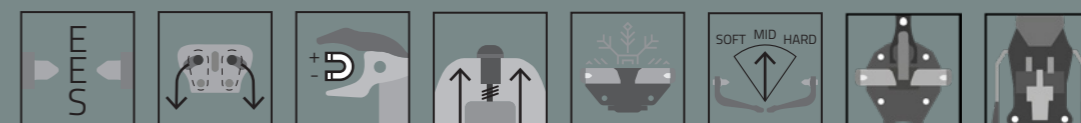

RAIDER 13 EVO

Peso: 370 grammi
Weight: 370 grams



Materiali: Alu 7075, POM, Acciaio inossidabile
Materials: Alu 7075, POM, Stainless steel

Sgancio puntale/
Toe part Release: 5-13

Sgancio puntale/
Toe part Release: 5-13

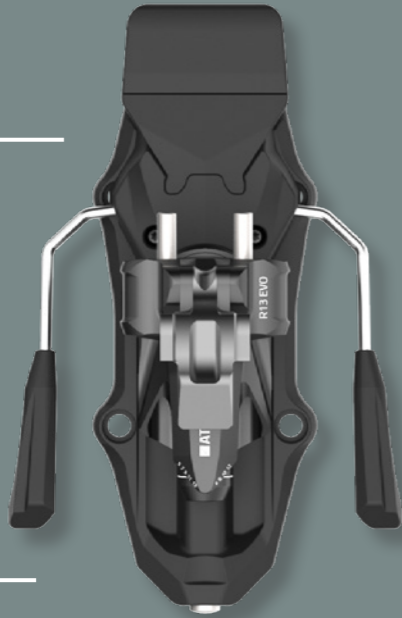

Regolazione/
Adjustment: 25mm

Skibrake:
86, 91, 97,
102, 108, 120mm

Modalità di camminata/
Walking modes:
Flat, +35, +49mm

Elasticità talloniera/
Heel elastic travel:
14mm (E.R.S)

NEW!
AUTOBRAKE
SYSTEM

Il nuovo Raider 13 Evo con talloniera dotata di ski brake automatico e un puntale rivoluzionario totalmente regolabile nei valori di sgancio. Ancora più aggressivo nella colorazione black.

A new heel piece with automatic ski-brake and improved toe piece featuring adjustable side release tension. Even bolder in black.

IDEAL
SKIS:

80 - 120mm 1000 - 1700 gr 50 - 110Kg

ATK® SYSTEMS



FREERAIDER 15 EVO

Peso: 390 grammi
Weight: 390 grams



Materiali: Alu 7075, POM, Acciaio inossidabile
Materials: Alu 7075, POM, Stainless steel

Sgancio puntale/
Toe part Release: 7-15

Sgancio puntale/
Toe part Release: 7-15

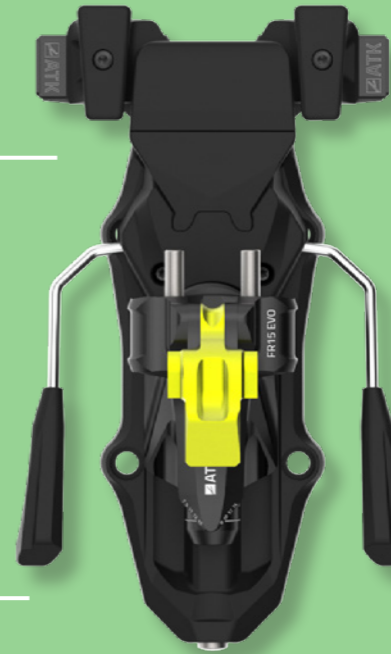

Regolazione/
Adjustment: 25mm

Skibrake:
86, 91, 97,
102, 108, 120mm

Modalità di camminata/
Walking modes:
Flat, +35, +49mm

Elasticità talloniera/
Heel elastic travel:
14mm (E.R.S)

Freeride Spacer AL13 incluso
AL13 Freeride Spacer included

NEW!
AUTOBRAKE
SYSTEM

Caratteristiche invariate rispetto al RAIDER 13 ma con un range di sgancio superiore. Freeride Spacer AL13 incluso.

Same features of RAIDER 13 but with a higher release range. AL13 Freeride Spacer included.

IDEAL
SKIS:

97 - 120mm 1000 - 1700 gr 60 - 120Kg

ATK® SYSTEMS



FRONT 12

Peso: 380 grammi
Weight: 380 grams

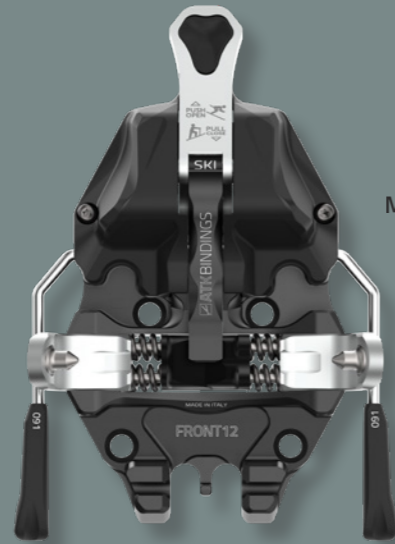

Materiali: Alu 7075, POM, Acciaio inossidabile
Materials: Alu 7075, POM, Stainless steel

Sgancio/
Release: 5-12



Regolazione/
Adjustment: 25mm

Ski brake:
86, 91, 97,
102, 108, 120mm

Modalità di camminata/
Walking modes:
Flat, +32, +37, +46, +52mm

Elasticità talloniera/
Heel elastic travel:
12mm (E.R.S)

La rivoluzione dello ski brake frontale per uno stile puro, dove servono semplicità e assoluta affidabilità anche nelle condizioni più estreme: per discese impeccabili sulle pareti più ripide.

The revolutionary front ski-brake for a pure skiing style, ideal for extreme conditions which require simplicity and reliability: impeccable downhill runs even on the steepest routes.

IDEAL
SKIS:



80 - 120mm



1000 - 1700 gr



50 - 100Kg

ATK® SYSTEMS



FREE TOURING CATEGORY

RECAP

305 Grammi
Grams

C-RAIDER 10

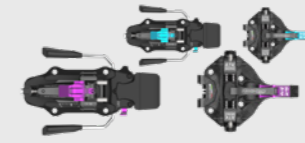

305 Grammi
Grams

C-RAIDER 12



335 Grammi
Grams

RAIDER 10

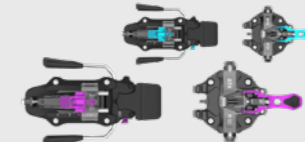

335 Grammi
Grams

RAIDER 12

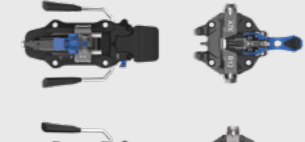
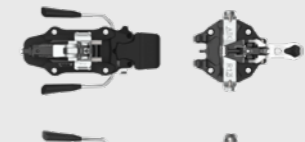

360 Grammi
Grams

FREERAIDER 14

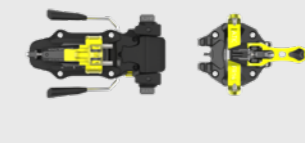

370 Grammi
Grams

RAIDER 11 EVO

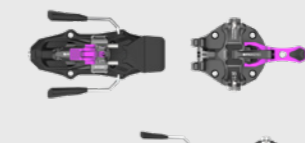

370 Grammi
Grams

RAIDER 13 EVO

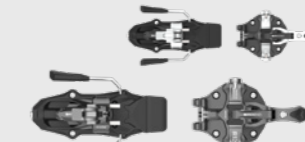

390 Grammi
Grams

FREERAIDER 15 EVO

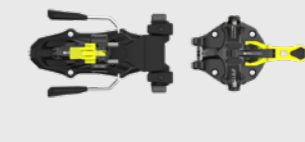

380 Grammi
Grams

FRONT 12

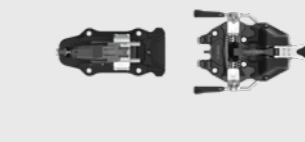

RENTAL

Progettati per soddisfare ogni esigenza del mercato del noleggio, con la qualità di sempre e i migliori materiali.

Designed to meet every need of rental market.



EASY RENT 10

COD. XER10W.XXX

COD. RM10.XXX

Peso: 290 grammi
Weight: 290 grams



Materiali: Alu 7075, POM, Acciaio inossidabile,
Composito di carbonio caricato al 30%
Materials: Alu 7075, POM, Stainless steel, 30%
Carbon fiber composite

Sgancio/
Release: 5-10

Skibrake:
86, 91, 97,
102, 108, 120mm

Elasticità talloniera/
Heel elastic travel:
10mm (E.R.S)

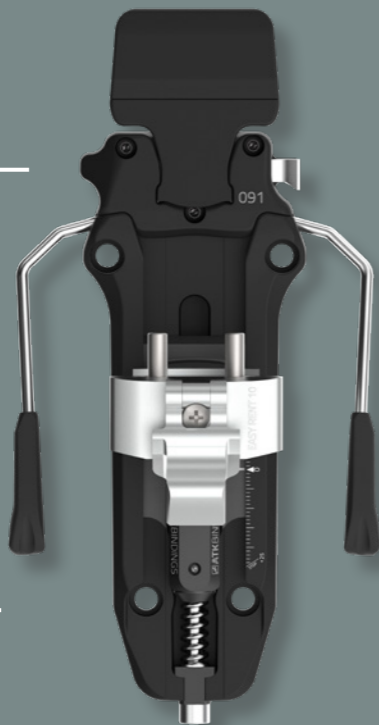

Regolazione/
Adjustment: 50mm

Modalità di camminata/
Walking modes:
Flat, +28, +41mm

Un design semplice per un attacco super leggero che garantisce un range di regolazione nella talloniera fino a 50mm e una sciata senza pensieri.

A simple design for super light bindings with adjustable heel piece ranging up to 50mm and no worries.

IDEAL
SKIS:



80 - 120mm



1000 - 1700 gr



50 - 90Kg

ATK® SYSTEMS

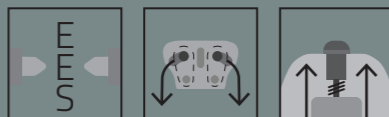

RENT ME 10

Peso: 380 grammi
Weight: 380 grams

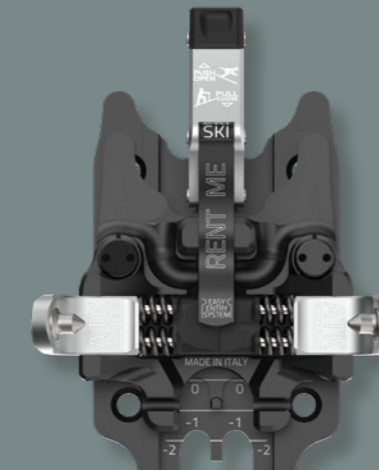

Materiali: Alu 7075, POM, Acciaio inossidabile
Materials: Alu 7075, POM, Stainless steel

Sgancio/
Release: 5-10

Skibrake:
86, 91, 97,
102, 108, 120mm

Elasticità talloniera/
Heel elastic travel:
10mm (E.R.S)

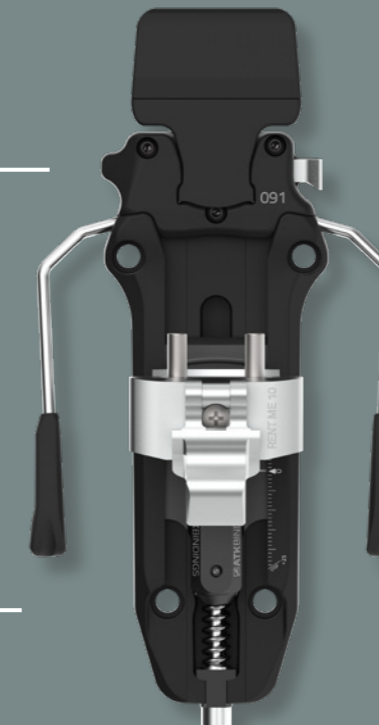

Regolazione: 80mm
(30 puntale, 50 talloniera)
Adjustment: 80mm
(30 toe, 50 heel)

Modalità di camminata/
Walking modes:
Flat, +30, +43mm

Puntale regolabile senza attrezzi fino a 30 mm, talloniera regolabile con l'avvitatore per 50 mm, per una corsa totale di 80mm: la soluzione ideale per il noleggio.

Adjustable tool-free toe piece up to 30mm, adjustable heel piece with screw ranging up to 50mm and totalling 80mm range: ideal for rentals.

IDEAL
SKIS:



80 - 120mm



1000 - 1700 gr



50 - 90Kg

ATK® SYSTEMS

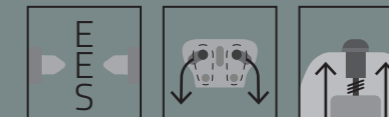

RENT ME 12 EVO

Peso: 450 grammi
Weight: 450 grams

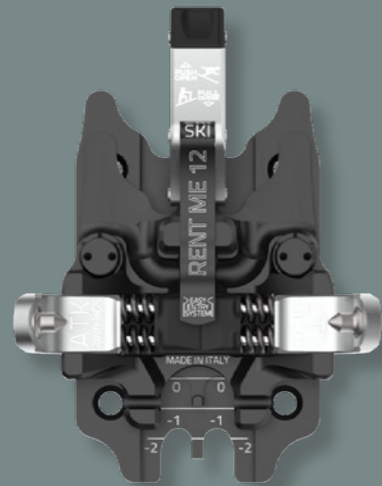

Materiali: Alu 7075, POM, Acciaio inossidabile
Materials: Alu 7075, POM, Stainless steel

Sgancio/
Release: 5-12

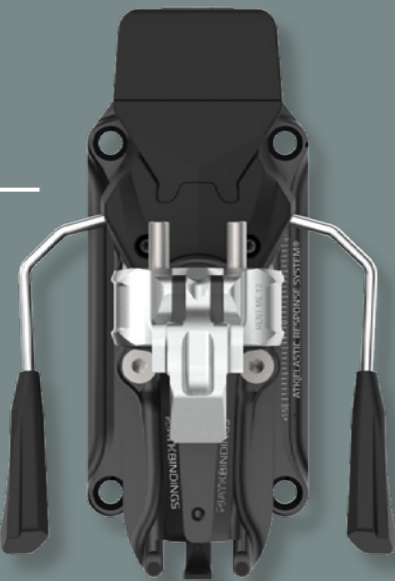

Regolazione: 60mm
(30 puntale, 30 talloniera)
Adjustment: 60mm
(30 toe, 30 heel)

Ski brake:
86, 91, 97,
102, 108, 120mm

Modalità di camminata/
Walking modes:
Flat, +37, +52mm

Elasticità talloniera/
Heel elastic travel:
8mm (E.R.S)

NEW!
AUTOBRAKE
SYSTEM

Fino a 60 mm di regolazione senza l'uso di alcun attrezzo: leggerezza e versatilità e una nuova talloniera con ski brake integrato.

Adjustable up to a 60mm range without the use of tools: lightness and versatility for the new heel piece with integrated ski-brake.

IDEAL
SKIS:



80 - 120mm



1000 - 1700 gr



50 - 100Kg

ATK® SYSTEMS

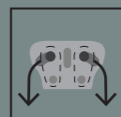

RACE



SPEED TOURING



TOURING



FREE TOURING



RENTAL



RACE

- 105 Grammi Grams
REVOLUTION World Cup
- 105 Grammi Grams
REVOLUTION LIGHTWEIGHT World Cup
- 110 Grammi Grams
SL World Cup
- 110 Grammi Grams
SL LIGHTWEIGHT World Cup
- 120 Grammi Grams
REVOLUTION BRAKE World Cup
- 120 Grammi Grams
REVOLUTION BRAKE LIGHTWEIGHT World Cup
- 130 Grammi Grams
SL BRAKE World Cup
- 130 Grammi Grams
SL BRAKE LIGHTWEIGHT World Cup
- 140 Grammi Grams
TROFEO BRAKE
- 140 Grammi Grams
TROFEO BRAKE LIGHTWEIGHT
- 145 Grammi Grams
TROFEO

SPEED TOURING

- 145* Grammi Grams
TROFEO PLUS 4-6-8-10 (* +59gr Speed Kit)
- 165* Grammi Grams
HAUTE ROUTE 8 (* +59gr Speed Kit)
- 165* Grammi Grams
HAUTE ROUTE 10 (* +59gr Speed Kit)
- 200 Grammi Grams
KULUAR 9LT
- 200 Grammi Grams
KULUAR 12LT

RENTAL

- 290 Grammi Grams
EASY RENT 10
- 390 Grammi Grams
RENT ME 10
- 450 Grammi Grams
RENT ME 12 EVO

TOURING

- 250 Grammi Grams
KULUAR 9 BRAKE
- 250 Grammi Grams
KULUAR 12 BRAKE
- 280 Grammi Grams
RT 8 EVO
- 280 Grammi Grams
RT 10 EVO
- 280 Grammi Grams
CREST 8
- 280 Grammi Grams
CREST 10
- 290 Grammi Grams
CANDY 5
- 320 Grammi Grams
FRONT 9

FREE TOURING

- 305 Grammi Grams
C-RAIDER 10
- 305 Grammi Grams
C-RAIDER 12
- 335 Grammi Grams
RAIDER 10
- 335 Grammi Grams
RAIDER 12
- 360 Grammi Grams
FREERAIDER 14
- 370 Grammi Grams
RAIDER 11 EVO
- 370 Grammi Grams
RAIDER 13 EVO
- 390 Grammi Grams
FREERAIDER 15 EVO
- 380 Grammi Grams
FRONT 12

ACCESSORI Accessories

SRA



Supporto rampant removibile puntali "ALU"
Removable "ALU" Toe piece crampons slot

8 Grammi / Grams

BR01

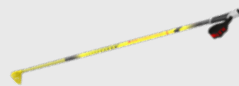

Bastoncini Carbon Kevlar®
Carbon Kevlar® Poles

85 Grammi/Mt Gramms/Mt
150 cm, da tagliare a misura
150 cm, customisable length

AL07



Freeride spacer per R12 2.0 | FR14 2.0
Freeride Spacer for R12 2.0 | FR14 2.0

29 Grammi / Grams

AL13



Freeride spacer 2022 per RT8 EVO, RT10 EVO,
R11 EVO, R13 EVO, FR15 EVO
Freeride spacer 2022 for RT8 EVO, RT10 EVO,
R11 EVO, R13 EVO, FR15 EVO

29 Grammi / Grams

AL11

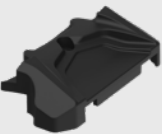

Cover per ogni tipo di attacco
Atk Bindings® con Ski brake posteriore
Brake seat cover fits with any Atk Bindings®
with rear brake

3 Grammi / Grams

AL14



Rialzo per puntale R11 EVO, R13 EVO,
FR15 EVO
Raider toe shim R11 EVO, R13 EVO,
FR15 EVO

10 Grammi / Grams
Misura / Size: 4 mm

SKRACE



Ski brake da gara
Race Ski Brake

60 Grammi / Grams
Misura/Size: 70 mm

SRB



Supporto rampant removibile puntali
"Carbon"
Removable "Carbon" Toe piece crampons
slot

7 Grammi / Grams

BE



Bastoncini speed touring (ALU7075)
Speed touring poles (ALU7075)

188 Grammi (dimensione 120 cm)
188 Grams (size 120 cm)
Lunghezza/Lenght: 120, 125, 130, 135,
140, 145 cm

AL09



Freeride spacer 2020 per R10, R12, FR14,
FR16, FRONT12
Freeride spacer 2020 for R10, R12,
FR14, FR16, FRONT12

29 Grammi / Grams

AL10

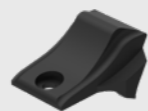

Alzatacchio per Candy 5
Raiser for Candy 5

10 Grammi / Grams

AL12



Rialzo per puntale R10/R12, FR14/FR16
Raider toe shim R10/R12, FR14/FR16

10 Grammi / Grams
Misura / Size: 4 mm

SKCR.XXX

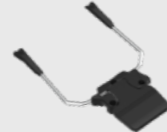

Ski brake posteriore
Rear Ski brake

47 Grammi / Grams
Misura/Size: 75, 86, 91, 97, 102, 108,
120 mm

R15.XXX



Ski brake da touring
Touring Ski Brake

81 Grammi / Grams
(96 Gr con viti e bulloni)
(96 Gr with screws and bolts)
Misura/Size: 75, 86, 91, 97, 102, 108,
120 mm

SKKRLXXX



Kular brake Kit
Kular 9LT-12LT / 9 Brake -
12 Brake / Release 10

85 Grammi / Grams
Misura / Size: 75, 86, 91, 97, 102, 108 mm

R01



Slitta di regolazione lunga
Long heel adjustment plate
Race bindings and HR10 / Trofeo Plus

20 Grammi / Grams
(+ 16 Gr per viteria)
(+ 16 Gr for screws)
Regolazione fino a 30 mm
Adjustment up to 30 mm

R06



Piastra Regolazione Talloniera per Sci con
Preforati TLT® e Radical®
Ski - Saver Plate for TLT® Speed & Radical
Pre-Drilled Skis

40 Grammi / Grams
(+5 Gr per viteria)
(+5 Gr for screws)
Regolazione fino a 25 mm
Adjustment up to 25 mm

R08A



Piastra di Adattamento Puntale XXL
XXL Toe Adjustment Plate

44 Grammi / Grams
(+9 Gr per viteria)
(+9 Gr for screws)

R16A



Piastra di adattamento free touring
Free touring toe plate

50 Grammi / Grams
(+9 Gr per viteria)
(+9 Gr for screws)
Misura: 27 mm
Size: 27 mm
Regolazione fino a 27 mm
Adjustment up to 27 mm

RAXXX



Rampant
Crampons

49 Gr / 70mm | a partire da 62 gr per le
altre misure
49 Gr / 70mm | from 62 Gr other sizes
Misure / Size: 70, 75, 86, 91, 97, 102,
108, 120, 135 mm

SBC02



Lacciolo in Kevlar®
Kevlar® Core Leash

15 Grammi / Grams

R04



Slitta per noleggio
Rental adjustment plate
Attacchi race e HR10 / Trofeo Plus
Race bindings and HR10 / Trofeo Plus

74 Grammi / Grams
(+5 Gr per viteria)
(+5 Gr for screws)
Regolazione fino a 60 mm
Adjustment up to 60 mm

R07



Slitta Regolazione Talloniera
per Sci con Preforati ATK®
Ski - Saver Plate for
ATK®Pre-Drilled Skis

40 Grammi / Grams
(+5 Gr per viteria)
(+5 Gr for screws)
Regolazione fino a 15 mm
Adjustment up to 15 mm

R13

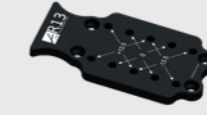

Piastra di adattamento puntale
Toe adjustment plate

30 Grammi / Grams
(+9 Gr per viteria)
(+9 Gr for screws)
Regolazione fino a 27 mm
Adjustment up to 27 mm

R17



Piastra di adattamento Race
Race toe plate

32 Grammi / Grams
(+13 Gr per viteria)
(+13 Gr for screws)
Regolazione fino a 30 mm
Adjustment up to 30 mm

RICAMBI Spare Parts

K07W



Sportellino gara
Race heel cover

Per SL WC prima serie 2011-2012
For SL WC first series 2011-2012

K13W



Sportellino SLR release e Trofeo SRL
Release
Trofeo heel cover

Colori disponibili: nero
Colours available: black

K15W



Sportellino "HAUTE ROUTE | 2.0"
"HAUTE ROUTE | 2.0" Heel cover

K08.1W



Kit molla a "U" in titanio "Lightweight"
"Lightweight" Titanium "U" Spring

K08.3W



Kit molla a "U" in Titanio "Lightweight" con
ROLLING-IN® SYSTEM
"Lightweight" Titanium "U" spring kit with
ROLLING-IN® SYSTEM

SKXXX



Ski brake frontale 2.0
Front brakes 2.0

57 Grammi / Grams
Compatibile con RT 2.0, R12 2.0, FR14 2.0
Fits with RT 2.0, R12 2.0, FR14 2.0
Misura/Size: 75, 86, 91, 97, 102, 108, 120mm

SKAUTO.XXX



Ski brake posteriore - AUTO
Rear brakes - AUTO

43 Grammi / Grams
Compatibile con R11/R13, FR15
Fits with R11/R13, FR15
Misura/Size: 86,91,97,102,108,120mm

K07.XW



Sportellino gara
Race heel cover

Colori disponibili: arancio (K07.1W),
argento (K07.2W), oro (K07.3W), viola
(K07.4W), nero (K07.5W), verde (K07.6W)
Colours available: orange (K07.1W), silver
(K07.2W), gold (K07.3W), purple (K07.4W),
black (K07.5W), green (K07.6W)

K14W



Sportellino "Trofeo"
"Trofeo" heel cover

K08W



Kit molla a "U" in titanio
Titanium "U" Spring

K08.2W



Kit molla a "U" in Titanio con
ROLLING-IN® System
Titanium "U" Spring kit
with ROLLING-IN® SYSTEM

K12.XW



Kit molla a "U" in Acciaio
Steel "U" Spring

Release: 4 (K12.4W), 6 (K12.6W), 8 (K12.8W), 10 (K12.10W)

SKCRXXX



Ski brake posteriore - MANU
Rear brakes - MANU

43 Grammi / Grams
Compatibile con tutti gli attacchi ATK
Bindings con ski brake posteriore
Fits with any ATK Bindings with rear brake

Size: 75,86,91,97,102,108,120,135mm

SKFNXXX



Ski brake frontale
Front brakes

57 Grammi / Grams
Compatibile con FRONT 9 e 12
Fits with FRONT 9 and 12
Misura/Size: 86, 91, 97, 102, 108, 120mm

PP01



Papere per bastoncini carbon Kevlar®
Carbon Kevlar® Poles Baskets

MA01



Manopole (Nero-Grigio) per bastoncini
in carbonio
Poles' grips - (Black-Grey) fits with
any Carbon Pole from Atk Bindings

V02



Viti di fissaggio autofilettanti (L13mm |
16 Pz)
Bindings countersunk screws kit (L13mm
| 16 Pcs)

V04



Viti di fissaggio autofilettanti testa svasata
(L15mm | 16 Pz)
Bindings countersunk screws kit (L15mm
| 16 Pcs)

V08



Kit viti per piastre R06,R07 | 8 Pz
Screws kit for ski saver plates
(R06, R07) | 8 Pcs

V15



Viti di fissaggio autofilettanti testa cilindrica
(L11mm | 8 Pz)
Bindings pan head screws kit
(L11mm | 8 Pcs)

V18



Viti di fissaggio autofilettanti testa cilindrica
(L13mm | 8 Pz)
Bindings pan head screws kit (L13mm | 8
PCS)

PP02



Papere per Bastoncini Carbon
Vertical Carbon Poles Baskets

V01



Viti di fissaggio autofilettanti testa svasata
(L11mm | 16 Pz)
Bindings countersunk screws kit (L11mm
| 16 Pcs)

V03



Kit viti+dadi slitte R01, R03P, R08P | 8 Pz
Screws+nuts kit for heel adj. plates (R01,
R03P, R08P) | 8 Pcs

V06



Kit viti per piastre (R03A,R08A,R13) | 8 Pz
Screws kit for toe adjustment plates
(R03A,R08A,R13) | 8 Pcs

V11



Viti in titanio per fissaggio attacco su sci (solo
attacco Revolution) (16 Pz)
Titanium bindings screws kit (for Revolution
bindings only) (16 Pcs)

V17



Kit assortimento viti rivenditore
Dealer Screw Kit

V20



Viti di fissaggio autofilettanti testa svasata
(L17mm | 8 Pz)
Bindings countersunk screws kit
(L17mm | 8 Pcs)

ATTREZZI Tools

SP3595 | SP3895 | SP4195



SUPERPUNTA® ATK Bindings Drillbit

- 1 SUPERPUNTA® Ø 3,5 MM – L 9,5 MM
- 1 SUPERPUNTA® Ø 3,8 MM – L 9,5 MM
- 1 SUPERPUNTA® Ø 4,1 MM – L 9,5 MM

M06



Maschera di Foratura
Automatic Drilling Jig

*(Fora il 100% della collezione ATK Bindings)
(Drills 100% of the ATK Bindings collection)*

SG01



Grasso ATK Bindings
Original ATK Bindings Grease

CL01



Pinze per molle a "U"
"U" Spring Handling Clamps

SD01



Cacciavite ATK Bindings
ATK Bindings Screwdriver

(PH2 & TX20)

ATKWS.2



Stazione di lavoro ATK Bindings
ATK Bindings Workstation

*Sistema di aggancio per attacchi lowtech
+ Rulli per stabilizzare lo sci + Morsa regolabile per sci con
larghezza compresa tra 60 e 140 mm + Piedistallo*

*Hooking system for lowtech bindings
+ Rolls to stabilize the ski + Adjustable vise for ski with
width from 60 to 140 mm + Pedestal*

EXP12

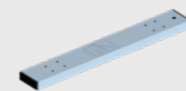

Espositore "ALU" satinato
per attacchi ATK Bindings
ATK Bindings Board Display

EXP06



ATK Bindings Bean banner

KT01.X



ATK Bindings Team T-Shirt

UNISEX
Taglie S, M, L, XL
Size S, M, L, XL

EXP11

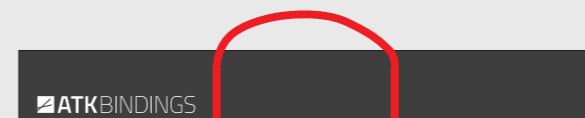

Borsa Porta Sci - Race e speed touring
Race/Speed Touring ski bag

*180 x 22 cm (bianca e rossa in nylon)
180 x 22 cm (red/white nylon)*

EXP13



Tappeto logo ATK Bindings
ATK Bindings Logo carpet

85 x 50 cm

EXP17



Cappellino visiera ATK Bindings
ATK Bindings Cap

EXP01



Espositore rotante
Rolling display

*Per 4 attacchi
For 4 bindings*

EXP10



Striscione in TNT ATK Bindings
ATK Bindings TNT Banner

EXP08 / EXP09



Lega sci ATK Bindings
ATK Bindings Ski strap

*Race Size: EXP08
Free Touring Size: EXP09*

EXP19



Borsa Porta Sci - Touring e Free touring
Touring/Free Touring ski bag

*190 x 30 cm (bianca e rossa in nylon)
190x 30 cm (red/white nylon)*

EXP16



Scaldacollo ATK Bindings R-PET |
100% materiale riciclato
ATK Bindings "R-PET" HEADBAND |
100% recycled material

POP & MERCH

EXP04



Vela ATK Bindings
ATK Bindings Flag

*Con basamento (h 4m)
With crankcase (h 4m)*

EXP05



Vela ATK Bindings
ATK Bindings Flag

*Con basamento (h 2m)
With crankcase (h 2m)*

DISTRIBUTORI ATK BINDINGS

ATK Bindings Distributors

ASIA

JAPAN
MIYAKO SPORTS CO.,LTD.
5-8-6, Asakusabashi, Taito-ku,
Tokyo, (JAPAN) 111-0053
Phone: +81-3-3863-6811
m.int.dpt@miyakosports.co.jp
www.miyakosports.co.jp

SOUTH KOREA
HIMAZONE
6-19 Gyeongchun-ro 227beon-gil
Guri-si Gyeonggi-do
South Korea 11926
Phone: +82.31.566.2336
kish7911@gmail.com

AMERICA

CANADA
BLACK DIAMOND EQUIPMENT LTD.
2084 East 3900 South
Salt Lake City, UT 84124
Phone: +1-800-775-7625
ski@bdel.com
www.blackdiamondequipment.com

CHILE
COMERCIAL ACROSSING S.p.A.
Av. Egaña - 1151, L16.
Puerto Montt
Phone: +56 652313595
contacto@australcrossing.cl
www.australcrossing.cl

USA
BLACK DIAMOND EQUIPMENT LTD.
2084 East 3900 South
Salt Lake City, UT 84124
Phone: +1-800-775-7625
ski@bdel.com
www.blackdiamondequipment.com

OCEANIA

AUSTRALIA
EVEREST SPORTS
28A, Ireland Street - 3741 Bright Victoria
Phone: 61 3 5755 2227
sales@everestsports.com.au
www.everestsports.com.au

NEW ZEALAND
ELEVATE PRODUCTS
19 Hay Street, Queenstown 9300
Phone: +64220643818; +64220761274
info@elevateproducts.net
www.elevateproducts.net

EUROPE

AUSTRIA
OUTDOOR HANDELSGES.M.B.H.
Andiesen 11
A-4774 St. Marienkirchen
Phone: +43 7711 33133-0
info@hagan-ski.com
www.hagan-ski.com

BULGARIA
NAMASTE LTD.
26b, Arch. Jordan Milanov - 1164 Sofia
Phone: +359 2866 9367
info@namaste-bg.com
www.namaste-bg.com

CZECH REPUBLIC
ALPSPORT
Tyršova 25
70200 Ostrava
Phone: +42 0 596 122 441
vo@alpsport.cz
www.alpsport.cz

FINLAND
OAC FINLAND OY
Lentolantie 15
36220 Kangasala
Phone: +35810 2291650
info@oac.fi
www.oac.fi

FRANCE
SPORT PULSION
49 Route du Nant
74350 Allonzier la Caille
Phone: +33 450465050
info@sportpulsion.fr
www.sportpulsion.fr

GEORGIA
MPLUS
25 vaja pshavela avenue,
Tbilisi
Phone: +995 32 231 91 01
info@mplus.ge
www.mplus.ge

GERMANY
AGENTUR UP – Christian Neiger
Ferdinand-Barth-Str.5
82467 Garmisch-Partenkirchen
Phone: +49 179 4938391
Phone: +49 8821 9673097
kontakt@outdoor-agentur-up.de
www.outdoor-agentur-up.de

GREECE
FIFTH ELEMENT
Dagkli & Papazoglou, Ioannina 454 44
Phone: +30 265 1037309
info@fifthelement.gr
www.fifthelement.gr

ICELAND
GÜMMIBÁTAR OG GALLAR SF / GG SPORT
Smðjuvegur 8
200 Kopavogur
Phone: +354 571 1020
ggsport.ishrafn@ggsport.is
www.ggsport.is

NETHERLANDS
SNOWCOUNTRY
Stoutenburgerlaan 17-B, 3836 PC, Stoutenburg-Noord, The Netherlands
Phone: +31 (0) 85 7500 160; +31 (0) 6 15 1717 14
maarten@snowcountry.nl
www.snowcountry.eu

NORWAY
ULTIMATE NORDIC AS
Tevlingveien 23
NO-1081 Oslo
Phone: +47 22 57 50 50
www.ultimatenordic.no

POLAND
MAJESTY / MJST Sp. z o.o.
ul. Wendy 15
81-341 Gdynia
Phone: +48 58 620 00 66
majesty@majestyskis.com
www.majestyskis.com

ROMANIA
SC ADRENALINA TOUR S.R.L.
STR. CARPATILOR 60 BRASOV 500269
Phone: +40 0748 202 071
shop@absolutoutdoor.ro
www.absolutoutdoor.ro

GAMONTEC S.R.L.
Str. Alba Iulia nr. 38
BAIA MARE, Maramures
Phone: 0758 089 455; 0770 279 023
contact@maramontsport.ro

SLOVENIA
SPORT 11/11
Poslovna cona A17
4208 Senčur
Phone: 0038659097425
info@11-11.si
www.11-11.si

SLOVAKIA
PISO SPORT
Samuela Nováka, 2194 - 026 01 Dolný Kubín (SLOVAKIA)
Phone: 00421 907 827 264
pisosport@pisosport.sk
www.skialpinista.sk

RUSSIA
ALPEX
Srednyaya Pereyaslavskaya ul. 13, stroenie 2
129110 Moscow
Phone: +7 495 631 1855
alpex@sherpa.ru
www.sherpa.ru

SPAIN AND ANDORRA
M.D.VIPER, S.A
C/De la Mora, 12
Pl. Badalona Sud – Granland,
08918 Badalona
Phone: +34933004600
vipex@vipex-sport.com
www.viper-sport.com

SWEDEN
BERGSBO PF AB
Göteborgsvägen 89,
43130 Mölndal
Phone: +46706913141
info@bergsbo.com
www.facebook.com/BergsboPF

SWITZERLAND
NEW ROCK S.A.
Via ponte di valle 9A
6964 Davesco
Phone: +41 91 935 14 00
info@newrocksport.ch
www.newrocksport.ch

UNITED KINGDOM
BACKCOUNTRY UK
The Sorting House, Wharfbank Mills, Ilkley Road,
Otley LS21 3JP
Phone: +441943816011
info@backcountryuk.com
www.backcountryuk.com

ITALY HEADQUARTERS
ATK SPORTS srl
Via della Fisica, 36
41042 Fiorano - Modena
Phone: +39 0536071831
info@atkbindings.com
www.atkbindings.com

ANALOGICO ECOLOGICO

UN CATALOGO GENTILE CON L'AMBIENTE

ECOLOGICAL ANALOGICAL

A CATALOGUE KIND TO THE ENVIRONMENT

La trasformazione digitale sta sempre più modificando il nostro modo di lavorare, la natura delle informazioni e il modo in cui le condividiamo con gli altri. La carta ha però ancora un ruolo molto significativo nelle attività quotidiane di un'azienda e il suo utilizzo ha un forte impatto sul pianeta sotto diversi aspetti. Per questo ATK Bindings si impegna ad acquistare e utilizzare la maggior percentuale possibile di carta riciclata orientandosi verso una visione ecosostenibile dei processi produttivi.

A digital revolution is changing the way we work, the information we read and the way we share it with others, nevertheless paper has still an important role in our daily activities and its use has a big impact on the planet from many points of view. This is why ATK Bindings is committed to purchasing and utilising a higher percentage of recycled paper for a more sustainable approach to manufacturing processes.

La carta su cui abbiamo scelto di stampare questo catalogo è riciclata al 100%, certificata FSC post-consumo, ovvero prodotta con legno e fibre ottenute dal riciclo di materiale giunto al termine del proprio utilizzo. Possiede inoltre la certificazione Ecolabel UE, il marchio di qualità ecologica dell'Unione Europea, che contraddistingue prodotti e servizi che, pur garantendo elevati standard prestazionali, sono caratterizzati da un ridotto impatto ambientale durante l'intero ciclo di vita. Anche per la fase di stampa abbiamo deciso di avvalerci di un partner che utilizza il 100% di energia pulita, alimentando tutti gli impianti e i macchinari esclusivamente con energia proveniente da fonte rinnovabile.

The paper we used for printing this catalogue is 100% post-consumer FSC certified recycled paper, sourced from recycled wood and fibres. It features the EU Ecolabel certification, a label of environmental excellence, awarded by the European Union to products and services meeting high environmental standards throughout their whole life-cycle, with a low impact on the environment. We also selected a printing company which utilises 100% clean and renewable energy for its machinery.

Perché è importante utilizzare carta riciclata?

Nel nostro paese il consumo di carta pro-capite è tra i più alti del mondo: per questo siamo convinti che riciclare carta e usare carta riciclata sia un nostro dovere per offrire un contributo responsabile agli obiettivi di sviluppo sostenibile globali.

Why is paper recycling so important?

Our Country has one of the highest levels of pro-capite paper consumption in the world: this is why we are convinced that recycling paper is our duty and we are committed to meeting global sustainability requirements.

Ridurre il fenomeno della deforestazione e le emissioni di Co2

Tagliare alberi senza rimpiazzarli provoca un sostanziale aumento dell'emissione di anidride carbonica nell'aria, che contribuisce in maniera nociva al riscaldamento globale.

Reducing deforestation and Co2 emissions

Cutting down trees without replacing them increases the carbon monoxide emission, with a negative impact on global warming.

Non costruire nuove discariche

Il numero delle discariche non è sufficiente per smaltire tutti i prodotti e la soluzione non può essere quella di costruirne altre o di sovraccargarle, ma invece quella di attuare idonee strategie di riciclo.

Say no to new landfills

There are not enough landfills for disposing all waste and the best solution is to focus on effective recycling strategies rather than building new landfills or overloading existing ones.

Salvaguardare gli habitat naturali

Abbattere alberi o intere vecchie foreste, che vengano o meno rimpiazzate, ha un forte impatto distruttivo anche sulla fauna che le abita e sull'intero ecosistema.

Safeguarding natural habitats

Pulling down trees or primeval forests, regardless of restocking, has a devastating effect on fauna and the eco-system.

Risparmiare acqua, tempo ed energia

Il processo di produzione della carta riciclata prevede l'utilizzo di un minor quantitativo di energia e acqua rispetto ai processi che impiegano solo fibra vergine. La carta riciclata inoltre può essere recuperabile fino a 6 volte.

Save water, energy and time

The production of recycled paper consumes less water and energy compared to processes which only use virgin fibres. Repurposed paper can be recycled up to 6 times.



Photo credits:
Concept, Design, Copywriting:

Anton Brey, Mark Chase, Giovanni Danieli, Layla Kerley, Maurizio Torri
ATK Bindings