

# PRODUCT INFORMATION PACKET



Model No: ORM5458BU

Catalog No: ORM5458BU

1/3-1/6 HP Condenser Fan Motor, 1075 RPM, 1 Speed, 208-230 Volts, 48 Frame, TEAO  
Condenser Fans Motors



Regal and Century are trademarks of Regal Beloit Corporation or one of its affiliated companies.  
©2020 Regal Beloit Corporation, All Rights Reserved. MC017097E





**Nameplate Specifications**

Output HP	<b>1/3-1/6 Hp</b>	Output KW	<b>0.25 kW</b>
Frequency	<b>60 Hz</b>	Voltage	<b>208-230 V</b>
Current	<b>1.9 A</b>	Speed	<b>1075 rpm</b>
Service Factor	<b>1</b>	Phase	<b>1</b>
Duty	<b>Air Over</b>	Insulation Class	<b>F</b>
Frame	<b>48</b>	Enclosure	<b>Totally Enclosed</b>
Thermal Protection	<b>Automatic</b>	Ambient Temperature	<b>80 °C</b>
UL	<b>Recognized</b>	CSA	<b>Y</b>
CE	<b>N</b>		

**Technical Specifications**

Electrical Type	<b>Permanent Split Capacitor</b>	Starting Method	<b>Across The Line</b>
Poles	<b>6</b>	Rotation	<b>Reversible</b>
Mounting	<b>Extended Studs</b>	Motor Orientation	<b>Any</b>
Drive End Bearing	<b>Ball</b>	Opp Drive End Bearing	<b>Ball</b>
Frame Material	<b>Rolled Steel</b>	Shaft Type	<b>Double Flat</b>
Overall Length	<b>11.49 in</b>	Frame Length	<b>3.50 in</b>
Shaft Diameter	<b>0.500 in</b>	Shaft Extension	<b>6.5 in</b>
Outline Drawing	<b>ORM5458BU-S01</b>	Connection Drawing	<b>614131-242</b>

This is an uncontrolled document once printed or downloaded and is subject to change without notice. Date Created:22/09/2020

GENERAL INFORMATION:

SHAFT RUNOUT: .001[.03] T.I.R. PER INCH LENGTH OF EXTENSION

BEARINGS: BALL

MOUNTING POSITION: ALL ANGLE

ELECTRICAL DATA:

OVERLOAD PROTECTOR: AUTOMATIC RESET (T.I. 7AM 304)

LINE LEADS: NO. 18 GA., .06[1.5] THK. XLP 125°C INSUL.

REVERSING PLUGS: NO. 18 GA., .03[.8] THK. XLP 125°C INSUL.

GROUND LEAD: NO. 18 GA., .03[.8] THK. (GREEN) INSUL.

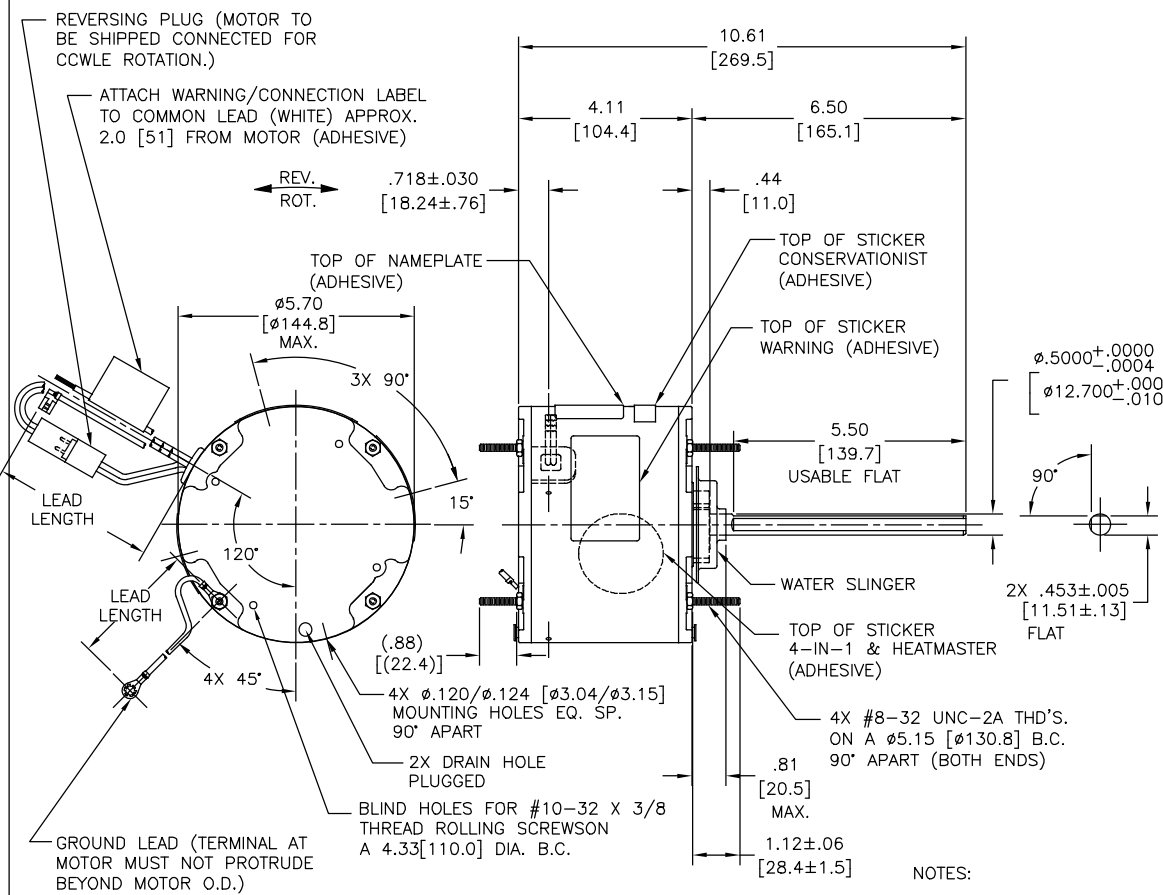

GREEN (GROUND)	12.0/13.0 [305/330]	#10 EYELET
BLACK/WHITE	3.0/5.0 [76/127]	REVERSING PLUG
BROWN	48.0/51.0 [1219/1295]	.25[6.4] FLAG
BROWN/WHITE	48.0/51.0 [1219/1295]	.25[6.4] FLAG
WHITE	48.0/51.0 [1219/1295]	.50[12.7] SKIN
BLACK	48.0/51.0 [1219/1295]	.50[12.7] SKIN
COLOR	LENGTH	TERMINAL OR STRIP LENGTH

REGAL-BELOIT CORPORATION (RBC) PROVIDES TECHNICAL ASSISTANCE TO OUR CUSTOMERS IN SEVERAL AREAS. SINCE RBC DOES NOT RECEIVE ALL DATA CONCERNING THE USE AND APPLICATION OF THE MOTOR, THE SUITABILITY OF THE MOTOR FOR THE APPLICATION MUST BE DETERMINED BY THE CUSTOMER.

DIMENSIONS WITHOUT TOLERANCES ARE FOR REFERENCE ONLY.

MAIN FRAME - OLE	ENCLOSED
END FRAME - OLE	ENCLOSED
MAIN FRAME - LE	ENCLOSED
END FRAME - LE	ENCLOSED

- NOTES:
- ATTACH INSTRUCTION SHEET 69P9-3 ONTO SHAFT APPROX. 1.0[25] FROM WATER SLINGER
  - 4X SCREWS 615982-001 & 4X HEX NUTS 7555A19H01 & 4X SCREWS 13833003 TO BE PUT IN A POLYBAG.

NAMEPLATE DATA:	EXTERNAL CONNECTION DIAGRAM
MODEL NO.: F48AF31A01 CUST. P/N: ORM5458BU HP: 1/3-1/6 ROT.: REVERSIBLE RPM: 1075 TYPE: UF FRAME: 48 VOLTS: 208-230 PH: 1 AMPS: 1.9 HZ: 60 INS.: F AMB.: 80°C DUTY: AIR OVER CAP.: 7.5 MFD/370 V ENCL: ENCLOSED UL LOGO CSA LOGO THERMALLY PROTECTED	SEP. CAP. BROWN BRN/WHT WHITE BLACK LINE ROTATION BLACK BLACK WHITE WHITE CCWLE BLACK WHITE WHITE BLACK CWLE

PERFORMANCE CURVE NO.	TORQUE @ 1075 RPM (25°C)	APPROVED SAMPLE	UL COMPONENT	CSA
C32514	32.6 OZ. FT.	0500467A	FILE # PRGY2	FILE # CLASS #
			E46412	LR43341 4211-01

DRAWING REVISION G ECO-0166568 SEE ECO	REVISION BY GELINE ZHAO APPROVED BY KEYUN GONG	DATE 05-23-2019 DATE 05-23-2019	DRAWN BY: R.ZHOU DATE: 01-11-2013 APPROVED BY: T.ZHAO DATE: 01-11-2013 PROCESS/FINISH	REGAL BELoit America, Inc. DESCRIPTION OUTLINE MATERIAL	CUSTOMER ORM5458BU	DISTRIBUTION SERVICE SHEET 1
---	---	--	---	--	-----------------------	---------------------------------

4

3

2

1

REV	ECO	REV BY	DATE	APPD	DATE
D	0029048	D.RODRIGUEZ	10-18-2012	J.HESS	10-18-2012

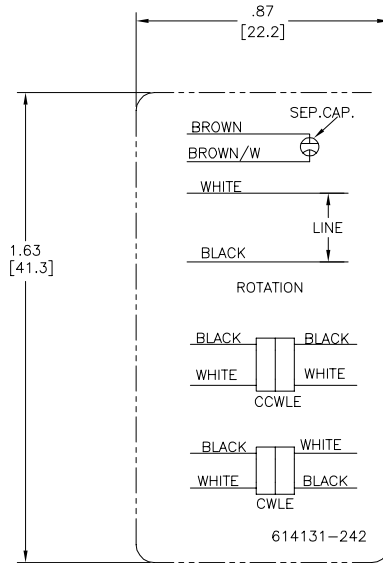

- NOTES:  
 1. FOR USE WITH 614129 OR 2513020-001 NAMEPLATE BLANKS  
 2. ----- INDICATES DIMENSION LIMITS

GEOMETRIC CHARACTERISTICS & SYMBOLS	
	FLATNESS
	STRAIGHTNESS
	ANGULARITY
	PERPENDICULARITY (SQUARENESS)
	PARALLELISM
	ROUNDNESS (CIRCULARITY)
	CYLINDRICITY
	PROFILE OF ANY SURFACE
	PROFILE OF ANY LINE
	RUNOUT
	TRUE POSITION
	CONCENTRICITY
	SYMMETRY

ASME Y14.5M 1994

UNLESS OTHERWISE SPECIFIED DIM. TOLERANCES ARE AS FOLLOWS:	
INCH	$\pm 1$ $\pm .02$ $\pm .005$ $\pm .0005$
mm	$\pm 0.5$ $\pm 0.13$ $\pm 0.013$
ANG. $\pm 50$ DEG	
REMOVE BURRS & BREAK SHARP EDGES:	
INCH	.003 - .015
mm	0.1 - 0.4
CORNER FILLETS TO:	
INCH	.020
mm	0.5
MACHINE SURFACES:	
INCH	125
mm	3.2
METRIC DIMS. SHOWN IN [BRACKETS]	

DR BY:	YL	04-15-2011
APPD:	HZ	04-15-2011
THIRD ANGLE PROJECTION		EDS DATE 11-11-2011 FORMAT REV H
CONFIDENTIAL: THIS DRAWING AND ITS INFORMATION ARE THE EXCLUSIVE AND CONFIDENTIAL PROPERTY OF REGAL-BELOIT CORPORATION AND ARE NOT TO BE DISCLOSED, DUPLICATED, DISTRIBUTED OR OTHERWISE USED WITHOUT THE WRITTEN CONSENT OF REGAL-BELOIT CORPORATION. -ALL RIGHTS RESERVED.		

<b>REGAL-BELOIT CORPORATION</b>	
DESCRIPTION CONN DIAGRAM-NAMEPLATE	
SIZE C	DWG NO 614131-242
SCALE NONE	SHEET 1

4

3

2

1

4

3

2

1

REVISION:	ECO	REVISADO POR:	FECHA:	APROBADO POR:	FECHA:
D	0029048	D.RODRIGUEZ	10-18-2012	J.HESS	10-18-2012

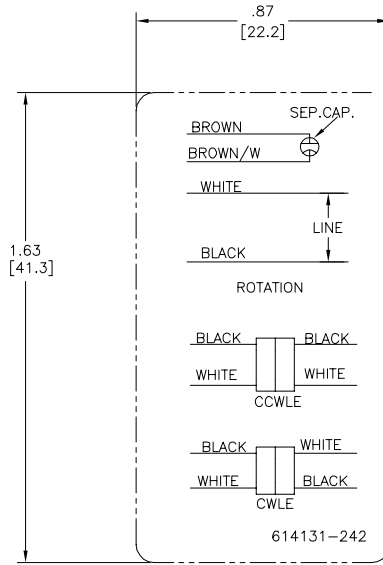

NOTAS:  
 1. PARA USO CON PLACA DE DATOS EN BLANCO REGAL-BELOIT BANKS  
 2. INDICATES DIMENSION LIMITS  
 INDICA LIMITES DE DIMENSION

CARACTERISTICAS DE GEOMETRIA Y SIMBOLOS ▽ PLANICIDAD — RECTITUD ∠ ANGULARIDAD ⊥ PERPENDICULARIDAD (A ESQUADRA) // PARALELISMO ○ REDONDEZ (CIRCULARIDAD) ⌀ CILINDRICIDAD ⌒ PERFIL DE CUALQUIER SUPERFICIE ∩ PERFIL DE CUALQUIER LINEA † VARIACION ⊕ POSICION REAL ⊙ CONCENRICIDAD ≡ SIMETRIA	A MENOS QUE SE ESPECIFIQUE DE OTRA MANERA, LAS TOLERANCIAS DE LAS DIMS. SON LAS SIGUIENTES: PULG ±.1 ±.02 ±.005 ±.0005 mm ±0.5 ±0.13 ±0.013 ANG. ±50 GRADOS ELIMINAR REBASAS Y ORILLAS FILOSAS DEL BORDE. PULG .003-.015 mm 0.1-0.4 FILETEAR ESQUINA: PULG .020 mm 0.5 MAQUINAR SUPERFICIES PULG 125 mm 3.2 DIMS METRICAS MOSTRADAS [PARENTESIS]	DIBUJADO POR: YL	04-15-2011	<b>REGAL-BELOIT CORPORATION</b>
		APROBADO POR: HZ	04-15-2011	
		TERCER ANGULO DE PROYECCION	FECHA EDS: 11-11-2011 REV. FORMATO: H	TAMANO: C
		CONFIDENCIAL: ESTE DIBUJO Y SU INFORMACION SON PROPIEDAD DE USO EXCLUSIVO Y CONFIDENCIAL DE REGAL-BELOIT CORPORATION. Y NO DEBERAN SER REVELADOS, DUPLICADOS, DISTRIBUIDOS O USARSE DE OTRA MANERA SIN EL CONSENTIMIENTO ESCRITO DE REGAL-BELOIT CORPORATION. -TODOS LOS DERECHOS RESERVADOS.		NUMERO DE DIBUJO: 614131-242
		ESCALA: NONE		HOJA: 1

4

3

2

1