

**WARNING** 120 Volts may cause serious injury from electrical shock. Disconnect power and shut off water supply before servicing.

### Water Line Inspection and Service Instructions for All Models

The humidifier is equipped with an in-line water strainer. See the following instructions for strainer cleaning.

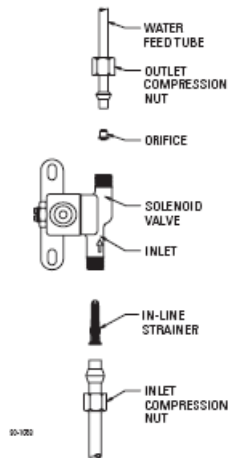

1. Disconnect electrical power to the furnace and shut off water supply.
2. Disconnect the water line at the inlet compression nut.
3. Remove the in-line strainer from inside the inlet side of the valve by using a small nail or wire.
4. Flush the in-line strainer clean or replace with a new strainer, Service Department, Part No. 4004.
5. Reconnect the inlet water line. **Double Wrench to Prevent Leaking.**
6. Disconnect the water feed tube at the outlet compression nut.
7. Inspect the water feed tube (plastic only) by gently flexing it and looking for cracks or signs of wear. Replace tube if it is cracked, brittle, or has been damaged.
8. Remove the orifice from the copper or plastic water feed tube and make sure this small opening is unplugged.
9. Replace the orifice with Part No. 4231 (yellow) and reconnect the water feed tube. **Double Wrench to Prevent Leaking.**
10. Turn on water supply and reconnect electrical power to the furnace.

## Aprilaire Models 400 & 400A

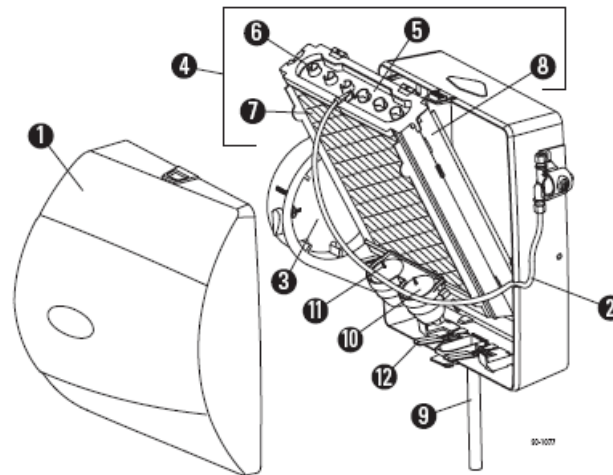

1. Front Cover
2. Feed Tube
3. Integral Bypass Damper
4. Water Panel Evaporative Assembly
5. Distribution Tray
6. "V" Notches
7. Water Panel Evaporator
8. Scale Control Insert/Float Chamber
9. Overflow Drain Line
10. Float Cover
11. Float
12. Water Level Sensor Assembly

1. Note Humidifier Control setting and turn dial to the "OFF" position.
2. Turn off water supply. Turn the integral bypass damper (3) to the "SUMMER" position.
3. Press the tabs in the latches on the top and bottom of front cover (1) and pull cover off base with both hands.
4. Carefully pull the plastic feed tube (2) out of the distribution tray (5) at the top of the Water Panel evaporative assembly (4). Tip the Water Panel evaporative assembly forward and lift it out of the humidifier. Do not tip the Water Panel evaporative assembly more than needed to clear the housing to avoid over-bending the water level sensor assembly (12).
5. Unsnap the distribution tray (5) from the scale control insert (8). Follow the instructions below depending upon the type of distribution tray in your humidifier:

**For trays with a synthetic fabric liner:** Lightly scrape out or brush off any mineral deposits, being careful not to stretch or loosen the synthetic fabric liner. Soaking the tray in vinegar or a lime-removing agent is helpful when trying to remove stubborn mineral deposits.

**For trays with granular coating:** Do not scrape off the granular coating, but lightly scrape out any mineral deposits and clean the "V" notches (6). This textured surface helps ensure even water flow for maximum performance.

6. Slide the used Water Panel evaporator (7) out of the scale control insert/float chamber and dispose of the Water Panel.
7. Remove the float cover (10) and inspect the floats (11) and float chamber for mineral build-up. Remove deposits as needed from floats, float chamber and scale control insert. Wash the parts with a disinfecting cleaner. Reassemble the floats and float cover. Make sure stems of both floats extend through openings in float cover and that floats move freely up and down.
8. Inspect the plastic feed tube (2) by gently flexing it and looking for cracks or signs of wear. Replace tube if it is cracked, brittle, or has been damaged.
9. Slide a new Aprilaire No. 45 Water Panel evaporator (7) into the scale control insert/float chamber (8). Snap the distribution tray (5) back on the scale control insert (8).
10. Reinstall the Water Panel evaporative assembly (4) into the humidifier. Take care not to over-bend the water level sensor assembly. Push the top of the Water Panel evaporative assembly firmly back until it snaps into place.
11. Push the end of the feed tube back firmly into the distribution tray. Replace the front cover.
12. Under normal operation the overflow drain line (9) will never have water in it. However, inspect it for mineral deposits and replace if necessary. Make sure the drain line has a constant downward slope and is not flattened or blocked.
13. Turn on the water supply. Return integral bypass damper to appropriate position.
14. Check system operation:  
**Automatic Humidifier Control:** (Automatic or Manual mode) Check system operation and reset Change Water Panel indicator by setting the knob to "Test/Reset". With furnace blower operating and furnace calling for heat, humidifier will operate for one minute. Do not leave in Test Mode as humidifier will not operate.
15. Set Humidifier Control to its original position.



RESEARCH PRODUCTS CORPORATION  
P.O. BOX 1467 • MADISON, WI 53701-1467

