



Air Conditioning & Heating

GSX14

SPLIT SYSTEM AIR CONDITIONER 14 SEER / 12.2 EER

COOLING CAPACITY: 18,000 - 60,000 BTU/H



Contents

Nomenclature	2
Product Specifications	3
Expanded Cooling Data	4
Performance Data	27
AHRI Ratings	29
Wiring Diagram	31
Dimensions	32
Accessories	32

Standard Features

- Energy-efficient compressor
- Factory-installed filter drier
- Copper tube/aluminum fin coil
- Service valves with sweat connections and easy-access gauge ports
- Contactor with lug connection
- Ground lug connection
- AHRI Certified
- ETL Listed

Cabinet Features

- Goodman® brand louvered sound control top design
- Steel louver coil guard
- Heavy-gauge galvanized-steel cabinet
- Attractive Architectural Gray powder-paint finish with 500-hour salt-spray approval
- Top and side maintenance access
- Single-panel access to controls with space provided for field-installed accessories
- When properly anchored, meets the 2010 Florida Building Code unit integrity requirements for hurricane-type winds (Anchor bracket kits available.)



* Complete warranty details available from your local dealer or at www.goodmanmfg.com. To receive the 10-Year Parts Limited Warranty, online registration must be completed within 60 days of installation. Online registration is not required in California or Quebec.

NOMENCLATURE

		G	S	X	14	036	1	AA		
		1	2	3	4,5	6,7,8	9	10,11		
Goodman® Brand										Engineering *
G	Standard-Feature Set									Major/ Minor Revisions
S	High-Feature Set									* Neither revision is used for order entry or inventory management.
D	2-Stage High-Feature Set									
Product Category										Electrical
S	Split System									1 208/230 V, 1 Phase, 60 Hz
										2 220/240 V, 1 Phase, 50 Hz
										3 208/230 V, 3 Phase, 60 Hz
Unit Type										Nominal Capacity
X	Condenser R-410A									018 1½ Tons
Z	Heat Pump R-410A									030 2½ Tons
										042 3½ Tons
										019 1½ Tons
										031 2½ Tons
										048 4 Tons
										024 2 Tons
										036 3 Tons
										060 5 Tons
										025 2 Tons
										037 3 Tons
										061 5 Tons
Efficiency										
13	13 SEER	16	16 SEER							
14	14 SEER	18	18 SEER							



SPECIFICATIONS

	GSX14 0181K*	GSX14 0191K*	GSX14 0241K*	GSX14 0251K*	GSX14 0301K*	GSX14 0311K*
CAPACITIES						
Nom Cool (BTU/h)	18,000	18,000	24,000	24,000	30,000	30,000
SEER/EER	14 / 12	14 / 12.2	14 / 12	14 / 12.2	14 / 12	14 / 12.2
Decibels	71	71	71	71	72	72
COMPRESSOR						
RLA	9.0	9.0	10.9	10.9	12.8	12.8
LRA	48	47.5	62.9	62.9	64	67.8
CONDENSER FAN MOTOR						
Hp	1/8	1/8	1/12	1/8	1/6	1/6
FLA	0.7	0.7	0.6	0.7	1.1	1.1
REFRIGERATION SYSTEM						
Refrigerant Line Size ¹						
Liquid Line Size ("O.D.)	3/8"	3/8"	3/8"	3/8"	3/8"	3/8"
Suction Line Size ("O.D.)	3/4"	3/4"	3/4"	3/4"	3/4"	3/4"
Refrigerant Connection Size						
Liquid Valve Size ("O.D.)	3/8"	3/8"	3/8"	3/8"	3/8"	3/8"
Suction Valve Size ("O.D.) ^{2 3}	3/4"	3/4"	3/4"	3/4"	3/4"	3/4"
Valve Type	Sweat	Sweat	Sweat	Sweat	Sweat	Sweat
Charge	68	68	70	70	80	90
Included piston:	0.052	0.053	0.057	0.057	0.065	0.063
ELECTRICAL DATA						
Voltage-Phase (60 Hz)	208/230-1	208/230-1	208/230-1	208/230-1	208/230-1	208/230-1
Minimum Circuit Ampacity ⁴	12	12	14.2	14.3	17.1	17.1
Max. Overcurrent Protection ⁵	20 amps	30 amps	25 amps	25 amps	25 amps	25 amps
Min/Max Volts	197/253	197/253	197/253	197/253	197/253	197/253
Conduit	1/2" or 3/4"	1/2" or 3/4"	1/2" or 3/4"	1/2" or 3/4"	1/2" or 3/4"	1/2" or 3/4"
EQUIPMENT WEIGHT						
	131	131	131	131	154	154
SHIPPING WEIGHT						
	146	146	146	146	172	172

¹ Line sizes denoted for 25' line sets, tested and rated in accordance with AHRI Standard 210/240.

For other line-set lengths or sizes, refer to the installation & Operating instructions and/or the long line-set guidelines.

² Installer will need to supply 3/4" to 7/8" adapters for suction line connections.

³ Installer will need to supply 7/8" to 1 1/8" adapters for suction line connections.

⁴ Wire size should be determined in accordance with National Electrical Codes; extensive wire runs will require larger wire sizes

⁵ Must use time-delay fuses or HACR-type circuit breakers of the same size as noted.

NOTES

- Always check the S&R plate for electrical data on the unit being installed.
- Unit is charged with refrigerant for 15' of 3/8" liquid line. System charge must be adjusted per Installation Instructions Final Charge Procedure.

SPECIFICATIONS (CONT.)

	GSX14 0361K*	GSX14 0371K*	GSX14 0421K*	GSX14 0481K*	GSX14 0601K*
CAPACITIES					
Nom Cool (BTU/h)	36,000	36,000	42,000	48,000	60,000
SEER/EER	14 / 12	14 / 12.2	14 / 12.2	14 / 11.7	14 / 11.7
Decibels	73	73	73	74	75
COMPRESSOR					
RLA	14.1	14.1	16.7	19.9	25.0
LRA	77	72.2	79	109	134
CONDENSER FAN MOTOR					
Hp	1/6	1/6	1/6	1/4	1/4
FLA	1.1	1.1	1.1	1.5	1.5
REFRIGERATION SYSTEM					
Refrigerant Line Size ¹					
Liquid Line Size ("O.D.)	3/8"	3/8"	3/8"	3/8"	3/8"
Suction Line Size ("O.D.)	7/8"	7/8"	1 1/8"	1 1/8"	1 1/8"
Refrigerant Connection Size					
Liquid Valve Size ("O.D.)	3/8"	3/8"	3/8"	3/8"	3/8"
Suction Valve Size ("O.D.) ^{2 3}	3/4"	3/4"	7/8"	7/8"	7/8"
Valve Type	Sweat	Sweat	Sweat	Sweat	Sweat
Charge	80	89	112	131	125
Included piston:	0.068	0.071	0.074	0.078	0.088
ELECTRICAL DATA					
Voltage-Phase (60 Hz)	208/230-1	208/230-1	208/230-1	208/230-1	208/230-1
Minimum Circuit Ampacity ⁴	18.7	18.7	22	26.4	32.8
Max. Overcurrent Protection ⁵	30 amps	30 amps	35 amps	45 amps	50 amps
Min/Max Volts	197/253	197/253	197/253	197/253	197/253
Conduit	1/2" or 3/4"	1/2" or 3/4"	1/2" or 3/4"	1/2" or 3/4"	1/2" or 3/4"
EQUIPMENT WEIGHT	181	181	189	220	192
SHIPPING WEIGHT	199	199	207	242	314

¹ Line sizes denoted for 25' line sets, tested and rated in accordance with AHRI Standard 210/240.

For other line-set lengths or sizes, refer to the installation & Operating instructions and/or the long line-set guidelines.

² Installer will need to supply 3/4" to 7/8" adapters for suction line connections.

³ Installer will need to supply 7/8" to 1 1/8" adapters for suction line connections.

⁴ Wire size should be determined in accordance with National Electrical Codes; extensive wire runs will require larger wire sizes

⁵ Must use time-delay fuses or HACR-type circuit breakers of the same size as noted.

NOTES

- Always check the S&R plate for electrical data on the unit being installed.
- Unit is charged with refrigerant for 15' of 3/8" liquid line. System charge must be adjusted per Installation Instructions Final Charge Procedure.

GSX140181K* + CA*F3636*6** + EEP + TXV

IDB		OUTDOOR AMBIENT TEMPERATURE												ENTERING INDOOR WET BULB TEMPERATURE													
		65				75				85				95				105				115					
		59	63	67	71	59	63	67	71	59	63	67	71	59	63	67	71	59	63	67	71	59	63	67	71		
70	525	MBh	18.3	18.6	19.1	-	18.1	18.4	19.0	-	17.7	17.9	18.5	-	16.8	17.1	17.7	-	15.8	16.1	16.6	-	14.9	15.2	15.7	-	
		S/T	0.57	0.50	0.37	-	0.58	0.51	0.38	-	0.60	0.53	0.40	-	0.62	0.55	0.42	-	1.00	0.57	0.44	-	1.00	0.62	0.49	-	
		ΔT	20	18	15	-	20	18	15	-	20	19	15	-	20	18	15	-	20	18	15	-	21	19	16	-	
	600	KW	1.09	1.09	1.09	-	1.22	1.22	1.21	-	1.36	1.36	1.35	-	1.51	1.51	1.50	-	1.68	1.68	1.67	-	1.87	1.87	1.87	-	
		Amps	4.0	4.0	4.0	-	4.6	4.6	4.6	-	5.2	5.2	5.2	-	5.9	5.9	5.9	-	6.7	6.7	6.7	-	7.6	7.6	7.6	-	
		HI PR	243	244	246	-	282	283	284	-	322	323	325	-	365	366	368	-	412	413	415	-	462	463	464	-	
	675	LO PR	122	123	126	-	129	131	134	-	136	137	140	-	141	143	146	-	147	148	151	-	153	155	158	-	
		MBh	18.6	18.8	19.4	-	18.4	18.6	19.2	-	17.9	18.2	18.7	-	17.1	17.3	17.9	-	16.1	16.3	16.9	-	15.2	15.4	16.0	-	
		S/T	0.63	0.56	0.43	-	0.64	0.57	0.44	-	0.66	0.59	0.46	-	0.68	0.61	0.48	-	1.00	0.63	0.50	-	1.00	0.68	0.55	-	
	75	525	ΔT	19	17	14	-	19	17	14	-	19	17	14	-	19	17	14	-	19	17	13	-	20	18	15	-
			KW	1.10	1.10	1.10	-	1.22	1.22	1.22	-	1.36	1.36	1.36	-	1.51	1.51	1.51	-	1.68	1.68	1.68	-	1.88	1.88	1.88	-
			Amps	4.0	4.0	4.0	-	4.6	4.6	4.6	-	5.2	5.2	5.2	-	5.9	5.9	5.9	-	6.7	6.7	6.7	-	7.6	7.6	7.6	-
600		HI PR	245	246	248	-	284	285	286	-	324	325	327	-	367	368	370	-	414	415	417	-	464	465	466	-	
		LO PR	115	119	129	-	118	122	133	-	122	126	138	-	126	130	141	-	128	132	144	-	131	135	148	-	
		MBh	18.8	19.1	19.6	-	18.7	18.9	19.5	-	18.2	18.5	19.0	-	17.4	17.6	18.2	-	16.4	16.6	17.2	-	15.5	15.7	16.3	-	
675		S/T	0.66	0.59	0.46	-	0.67	0.60	0.47	-	0.69	0.62	0.49	-	1.00	0.64	0.51	-	1.00	0.66	0.53	-	1.00	0.71	0.58	-	
		ΔT	18	16	13	-	18	16	13	-	18	16	13	-	18	16	13	-	18	16	12	-	19	17	14	-	
		KW	1.10	1.10	1.10	-	1.23	1.23	1.23	-	1.37	1.37	1.37	-	1.52	1.52	1.52	-	1.69	1.69	1.69	-	1.89	1.89	1.88	-	
75		525	Amps	4.1	4.0	4.0	-	4.6	4.6	4.6	-	5.3	5.3	5.2	-	6.0	5.9	5.9	-	6.7	6.7	6.7	-	7.6	7.6	7.6	-
			HI PR	247	248	250	-	286	287	288	-	326	327	329	-	369	370	372	-	416	417	419	-	466	467	468	-
			LO PR	126	127	130	-	133	134	138	-	139	141	144	-	145	146	150	-	150	152	155	-	157	159	162	-
	600	MBh	18.3	18.6	19.1	20.0	18.2	18.4	19.0	19.8	17.7	17.9	18.5	19.3	16.9	17.1	17.7	18.5	15.9	16.1	16.7	17.5	14.9	15.2	15.7	16.6	
		S/T	0.70	0.62	0.50	0.36	0.70	0.63	0.50	0.37	1.00	0.65	0.53	0.39	1.00	0.67	0.54	0.41	1.00	0.69	0.57	0.43	1.00	1.00	0.61	0.48	
		ΔT	24	22	19	15	24	22	19	15	25	23	19	16	24	22	19	15	24	22	19	15	25	23	20	16	
	675	KW	1.09	1.09	1.09	1.10	1.22	1.22	1.21	1.22	1.36	1.36	1.35	1.36	1.51	1.51	1.50	1.51	1.68	1.67	1.67	1.68	1.87	1.87	1.87	1.88	
		Amps	4.0	4.0	4.0	4.0	4.6	4.6	4.6	4.6	5.2	5.2	5.2	5.2	5.9	5.9	5.9	5.9	6.7	6.7	6.7	6.7	7.6	7.6	7.6	7.6	
		HI PR	243	244	246	250	282	283	285	289	322	323	325	329	365	366	368	372	412	413	415	419	462	463	465	469	
	75	525	LO PR	122	123	126	132	129	131	134	139	136	137	140	145	141	143	146	151	147	148	151	156	153	155	158	163
			MBh	18.6	18.8	19.4	20.2	18.4	18.7	19.2	20.0	17.9	18.2	18.7	19.6	17.1	17.4	17.9	18.7	16.1	16.4	16.9	17.7	15.2	15.4	16.0	16.8
			S/T	0.75	0.68	0.55	0.42	0.76	0.69	0.56	0.42	1.00	0.71	0.58	0.45	1.00	0.73	0.60	0.47	1.00	0.75	0.62	0.49	1.00	1.00	0.67	0.54
600		ΔT	23	21	18	14	23	21	18	14	23	22	18	14	23	21	18	14	23	21	18	14	24	22	19	15	
		KW	1.10	1.10	1.10	1.10	1.22	1.22	1.22	1.23	1.36	1.36	1.36	1.37	1.51	1.51	1.51	1.52	1.68	1.68	1.68	1.69	1.88	1.88	1.88	1.89	
		Amps	4.0	4.0	4.0	4.1	4.6	4.6	4.6	4.6	5.2	5.2	5.2	5.3	5.9	5.9	5.9	6.0	6.7	6.7	6.7	6.7	7.6	7.6	7.6	7.6	
675		HI PR	246	247	248	253	284	285	287	291	324	325	327	331	367	368	370	374	414	415	417	421	464	465	467	471	
		LO PR	124	125	128	133	131	132	136	141	137	139	142	147	143	144	148	153	148	150	153	158	155	157	160	165	
		MBh	18.9	19.1	19.7	20.5	18.7	18.9	19.5	20.3	18.2	18.5	19.0	19.9	17.4	17.6	18.2	19.0	16.4	16.6	17.2	18.0	15.5	15.7	16.3	17.1	
675		S/T	0.79	0.71	0.59	0.45	0.79	0.72	0.59	0.46	1.00	0.74	0.62	0.48	1.00	0.76	0.63	0.50	1.00	0.78	0.65	0.52	1.00	1.00	0.70	0.57	
		ΔT	22	20	17	13	22	20	17	13	23	21	17	14	22	20	17	13	22	20	17	13	23	21	18	14	
		KW	1.10	1.10	1.10	1.11	1.23	1.23	1.23	1.24	1.37	1.37	1.37	1.37	1.52	1.52	1.52	1.53	1.69	1.69	1.68	1.69	1.89	1.88	1.88	1.89	
675	Amps	4.0	4.0	4.0	4.1	4.6	4.6	4.6	4.7	5.3	5.3	5.2	5.3	6.0	5.9	5.9	6.0	6.7	6.7	6.7	6.8	7.6	7.6	7.6	7.7		
	HI PR	248	249	250	255	286	287	289	293	326	327	329	333	369	370	372	376	416	417	419	423	466	467	469	473		
	LO PR	126	127	130	135	133	134	138	143	139	141	144	149	145	146	150	155	150	152	155	160	157	159	162	167		

IDB: Entering Indoor Dry Bulb Temperature
 High and low pressures are measured at the liquid and suction service valves.
 Shaded area reflects ACCA (TVA) conditions
 kW = Total system power
 Amps = outdoor unit amps (comp.+fan)

GSX140181K* + CA*F3636*6** + EEP + TXV (CONT.)

IDB		OUTDOOR AMBIENT TEMPERATURE												ENTERING INDOOR WET BULB TEMPERATURE											
		65				75				85				95				105				115			
		59	63	67	71	59	63	67	71	59	63	67	71	59	63	67	71	59	63	67	71	59	63	67	71
80	MBh	18.4	18.7	19.2	20.1	18.3	18.5	19.1	19.9	17.8	18.0	18.6	19.4	17.0	17.2	17.8	18.6	15.9	16.2	16.8	17.6	15.0	15.3	15.8	16.7
	S/T	0.82	0.74	0.62	0.5	1.00	0.75	0.62	0.49	1.00	0.77	0.64	0.5	1.00	0.79	0.66	0.53	1.00	1.00	0.68	0.6	1.00	1.00	0.73	0.60
	ΔT	28	27	23	19	28	27	23	19	29	27	23	20	28	27	23	19	28	26	23	19	29	27	24	20
	KW	1.09	1.09	1.09	1.1	1.22	1.22	1.21	1.22	1.36	1.36	1.35	1.4	1.51	1.51	1.50	1.51	1.68	1.68	1.67	1.7	1.87	1.87	1.87	1.88
	Amps	4.0	4.0	4.0	4.0	4.6	4.6	4.6	4.6	5.2	5.2	5.2	5.2	5.9	5.9	5.9	5.9	6.7	6.7	6.7	6.7	7.6	7.6	7.6	7.6
	HI PR	244	245	247	251	282	283	285	289	322	324	325	329	366	367	369	373	412	414	415	419	462	463	465	469
LO PR	122	124	127	132	130	131	134	140	136	138	141	146	142	143	146	151	147	149	152	157	154	155	158	164	
600	MBh	18.7	18.9	19.5	20.3	18.5	18.8	19.3	20.1	18.0	18.3	18.8	19.7	17.2	17.5	18.0	18.8	16.2	16.4	17.0	17.8	15.3	15.5	16.1	16.9
	S/T	1.00	0.80	0.67	0.5	1.00	0.81	0.68	0.54	1.00	0.83	0.70	0.6	1.00	0.85	0.72	0.58	1.00	1.00	0.74	0.6	1.00	1.00	0.79	0.65
	ΔT	27	25	22	18	27	25	22	18	28	26	22	19	27	25	22	18	27	25	22	18	28	26	23	19
	KW	1.10	1.10	1.10	1.1	1.22	1.22	1.22	1.23	1.36	1.36	1.36	1.4	1.51	1.51	1.51	1.52	1.68	1.68	1.68	1.7	1.88	1.88	1.88	1.89
	Amps	4.0	4.0	4.0	4.1	4.6	4.6	4.6	4.6	5.2	5.2	5.2	5.3	5.9	5.9	5.9	6.0	6.7	6.7	6.7	6.7	7.6	7.6	7.6	7.6
	HI PR	246	247	249	253	284	285	287	291	325	326	327	332	368	369	371	375	415	416	417	422	464	465	467	471
LO PR	124	126	129	134	132	133	136	141	138	140	143	148	143	145	148	153	149	150	153	159	156	157	160	165	
675	MBh	18.9	19.2	19.8	20.6	18.8	19.0	19.6	20.4	18.3	18.6	19.1	19.9	17.5	17.7	18.3	19.1	16.5	16.7	17.3	18.1	15.6	15.8	16.4	17.2
	S/T	1.00	0.83	0.70	0.6	1.00	0.84	0.71	0.57	1.00	0.86	0.73	0.6	1.00	1.00	0.75	0.62	1.00	1.00	0.77	0.6	1.00	1.00	0.82	0.69
	ΔT	26	25	21	17	26	24	21	17	27	25	21	18	26	24	21	17	26	24	21	17	27	25	22	18
	KW	1.10	1.10	1.10	1.1	1.23	1.23	1.23	1.24	1.37	1.37	1.37	1.4	1.52	1.52	1.52	1.53	1.69	1.69	1.69	1.7	1.89	1.89	1.88	1.89
	Amps	4.1	4.1	4.0	4.1	4.6	4.6	4.6	4.7	5.3	5.3	5.3	5.3	6.0	6.0	5.9	6.0	6.7	6.7	6.7	6.8	7.6	7.6	7.6	7.7
	HI PR	248	249	251	255	286	287	289	293	327	328	329	334	370	371	373	377	417	418	419	424	466	467	469	473
LO PR	126	128	131	136	134	135	138	143	140	141	145	150	145	147	150	155	151	152	155	161	158	159	162	167	

IDB		OUTDOOR AMBIENT TEMPERATURE												ENTERING INDOOR WET BULB TEMPERATURE											
		65				75				85				95				105				115			
		59	63	67	71	59	63	67	71	59	63	67	71	59	63	67	71	59	63	67	71	59	63	67	71
85	MBh	18.7	19.0	19.5	20.4	18.6	18.8	19.4	20.2	18.1	18.3	18.9	19.7	17.3	17.5	18.1	18.9	16.3	16.5	17.1	17.9	15.3	15.6	16.1	17.0
	S/T	1.00	0.84	0.71	0.58	1.00	0.85	0.72	0.58	1.00	1.00	0.74	0.61	1.00	1.00	0.76	0.62	1.00	1.00	0.78	0.64	1.00	1.00	1.00	0.69
	ΔT	32	30	27	23	32	30	27	23	32	30	27	23	32	30	27	23	32	30	26	23	33	31	28	24
	KW	1.09	1.09	1.09	1.10	1.22	1.22	1.22	1.23	1.36	1.36	1.36	1.37	1.51	1.51	1.51	1.52	1.68	1.68	1.68	1.69	1.88	1.88	1.87	1.88
	Amps	4.0	4.0	4.0	4.0	4.6	4.6	4.6	4.6	5.2	5.2	5.2	5.3	5.9	5.9	5.9	5.9	6.7	6.7	6.7	6.7	7.6	7.6	7.6	7.6
	HI PR	245	246	248	252	283	284	286	290	324	325	326	331	367	368	370	374	414	415	416	421	463	464	466	470
LO PR	124	126	129	134	132	133	136	141	138	140	143	148	144	145	148	153	149	150	154	159	156	157	160	165	
600	MBh	19.0	19.2	19.8	20.6	18.8	19.1	19.6	20.4	18.3	18.6	19.1	20.0	17.5	17.8	18.3	19.1	16.5	16.8	17.3	18.1	15.6	15.8	16.4	17.2
	S/T	1.00	0.90	0.77	0.63	1.00	0.90	0.77	0.64	1.00	1.00	0.80	0.66	1.00	1.00	0.82	0.68	1.00	1.00	0.84	0.70	1.00	1.00	1.00	0.75
	ΔT	31	29	26	22	31	29	26	22	31	29	26	22	31	29	26	22	31	29	25	22	32	30	26	23
	KW	1.10	1.10	1.10	1.11	1.23	1.23	1.22	1.23	1.37	1.37	1.36	1.37	1.52	1.52	1.51	1.52	1.69	1.68	1.68	1.69	1.88	1.88	1.88	1.89
	Amps	4.0	4.0	4.0	4.1	4.6	4.6	4.6	4.6	5.3	5.2	5.2	5.3	5.9	5.9	5.9	6.0	6.7	6.7	6.7	6.7	7.6	7.6	7.6	7.7
	HI PR	247	248	250	254	285	287	288	292	326	327	328	333	369	370	372	376	416	417	418	423	465	467	468	472
LO PR	126	127	131	136	133	135	138	143	140	141	144	150	145	147	150	155	151	152	155	160	157	159	162	167	
675	MBh	19.3	19.5	20.1	20.9	19.1	19.4	19.9	20.7	18.6	18.9	19.4	20.3	17.8	18.1	18.6	19.4	16.8	17.0	17.6	18.4	15.9	16.1	16.7	17.5
	S/T	1.00	0.93	0.80	0.66	1.00	1.00	0.81	0.67	1.00	1.00	0.83	0.69	1.00	1.00	0.85	0.71	1.00	1.00	0.87	0.73	1.00	1.00	1.00	0.78
	ΔT	30	28	25	21	30	28	25	21	30	28	25	21	30	28	25	21	30	28	24	21	31	29	26	22
	KW	1.11	1.11	1.10	1.11	1.23	1.23	1.23	1.24	1.37	1.37	1.37	1.38	1.52	1.52	1.52	1.53	1.69	1.69	1.69	1.70	1.89	1.89	1.89	1.90
	Amps	4.1	4.1	4.1	4.1	4.6	4.6	4.6	4.7	5.3	5.3	5.3	5.3	6.0	6.0	6.0	6.0	6.7	6.7	6.7	6.8	7.6	7.6	7.6	7.7
	HI PR	249	250	252	256	287	289	290	294	328	329	330	335	371	372	374	378	418	419	420	425	467	469	470	474
LO PR	128	129	133	138	135	137	140	145	142	143	146	152	147	149	152	157	153	154	157	162	159	161	164	169	

IDB: Entering Indoor Dry Bulb Temperature
 High and low pressures are measured at the liquid and suction service valves.
 Shaded area reflects AHRI conditions
 kW = Total system power
 Amps = outdoor unit amps (comp.-fan)

GSX140191K* + CA*F3636*6** + EEP + TXV

IDB		OUTDOOR AMBIENT TEMPERATURE												ENTERING INDOOR WET BULB TEMPERATURE											
		65				75				85				95				105				115			
		59	63	67	71	59	63	67	71	59	63	67	71	59	63	67	71	59	63	67	71	59	63	67	71
70	550	18.1	18.4	18.9	-	18.0	18.2	18.8	-	17.5	17.8	18.3	-	16.7	17.0	17.5	-	15.7	16.0	16.5	-	14.8	15.1	15.6	-
	S/T	0.65	0.57	0.44	-	0.65	0.58	0.45	-	0.68	0.60	0.47	-	1.00	0.62	0.49	-	1.00	0.64	0.51	-	1.00	0.69	0.56	-
	ΔT	20	18	14	-	20	18	14	-	20	18	14	-	20	18	14	-	19	18	14	-	21	19	15	-
	KW	1.05	1.05	1.05	-	1.17	1.17	1.16	-	1.30	1.30	1.29	-	1.44	1.44	1.43	-	1.59	1.59	1.59	-	1.78	1.78	1.77	-
	Amps	3.9	3.9	3.9	-	4.4	4.4	4.4	-	5.0	5.0	5.0	-	5.7	5.7	5.6	-	6.4	6.4	6.4	-	7.2	7.2	7.2	-
	HI PR	240	241	242	-	277	278	280	-	316	318	319	-	359	360	362	-	404	405	407	-	453	454	456	-
LO PR	125	126	129	-	132	134	137	-	139	140	143	-	144	146	149	-	150	151	154	-	156	158	161	-	
70	600	18.3	18.6	19.1	-	18.2	18.4	19.0	-	17.7	18.0	18.5	-	16.9	17.2	17.7	-	15.9	16.2	16.7	-	15.0	15.3	15.8	-
	S/T	0.67	0.60	0.47	-	0.68	0.61	0.47	-	0.70	0.63	0.50	-	1.00	0.65	0.52	-	1.00	0.67	0.54	-	1.00	0.72	0.59	-
	ΔT	19	17	13	-	19	17	13	-	19	17	14	-	19	17	13	-	19	17	13	-	20	18	14	-
	KW	1.05	1.05	1.05	-	1.17	1.17	1.17	-	1.30	1.30	1.30	-	1.44	1.44	1.44	-	1.60	1.60	1.59	-	1.78	1.78	1.78	-
	Amps	3.9	3.9	3.9	-	4.4	4.4	4.4	-	5.0	5.0	5.0	-	5.7	5.7	5.7	-	6.4	6.4	6.4	-	7.2	7.2	7.2	-
	HI PR	241	242	244	-	279	280	281	-	318	319	321	-	360	361	363	-	406	407	409	-	455	456	457	-
LO PR	126	128	131	-	133	135	138	-	140	142	145	-	146	147	150	-	151	152	156	-	158	159	162	-	
70	675	18.7	18.9	19.5	-	18.5	18.8	19.3	-	18.1	18.3	18.9	-	17.3	17.5	18.1	-	16.3	16.5	17.1	-	15.4	15.6	16.2	-
	S/T	0.69	0.62	0.49	-	0.70	0.62	0.49	-	0.72	0.65	0.52	-	1.00	0.67	0.53	-	1.00	0.69	0.56	-	1.00	0.74	0.61	-
	ΔT	18	16	13	-	18	16	12	-	18	16	13	-	18	16	12	-	18	16	12	-	19	17	13	-
	KW	1.06	1.06	1.06	-	1.18	1.17	1.17	-	1.30	1.30	1.30	-	1.45	1.44	1.44	-	1.60	1.60	1.60	-	1.79	1.79	1.78	-
	Amps	3.9	3.9	3.9	-	4.5	4.5	4.5	-	5.1	5.1	5.0	-	5.7	5.7	5.7	-	6.4	6.4	6.4	-	7.3	7.3	7.2	-
	HI PR	243	244	246	-	281	282	283	-	320	321	323	-	362	363	365	-	408	409	411	-	457	458	459	-
LO PR	128	130	133	-	136	137	141	-	142	144	147	-	148	149	153	-	153	155	158	-	160	162	165	-	
75	550	18.2	18.4	18.9	19.8	18.0	18.2	18.8	19.6	17.5	17.8	18.3	19.1	16.7	17.0	17.5	18.3	15.7	16.0	16.5	17.3	14.8	15.1	15.6	16.4
	S/T	0.77	0.70	0.57	0.43	0.78	0.70	0.57	0.43	1.00	0.73	0.60	0.46	1.00	0.75	0.62	0.48	1.00	0.77	0.64	0.50	1.00	0.80	0.69	0.55
	ΔT	24	22	18	15	24	22	18	15	24	22	18	14	23	21	18	14	24	22	18	14	25	23	19	16
	KW	1.05	1.05	1.05	1.06	1.17	1.16	1.16	1.17	1.30	1.29	1.29	1.30	1.44	1.43	1.43	1.44	1.59	1.59	1.59	1.60	1.78	1.78	1.77	1.78
	Amps	3.9	3.9	3.9	3.9	4.4	4.4	4.4	4.4	5.0	5.0	5.0	5.0	5.7	5.7	5.6	5.7	6.4	6.4	6.4	6.4	7.2	7.2	7.2	7.2
	HI PR	240	241	243	247	277	278	280	284	317	318	319	324	359	360	362	366	405	406	407	411	453	454	456	460
LO PR	125	126	129	134	132	134	137	142	139	140	143	148	144	146	149	154	150	151	154	159	156	158	161	166	
75	600	18.4	18.6	19.1	20.0	18.2	18.4	19.0	19.8	17.7	18.0	18.5	19.3	16.9	17.2	17.7	18.5	15.9	16.2	16.7	17.5	15.0	15.3	15.8	16.6
	S/T	0.80	0.73	0.59	0.45	1.00	0.73	0.60	0.46	1.00	0.76	0.62	0.48	1.00	0.77	0.64	0.50	1.00	0.80	0.66	0.53	1.00	1.00	0.71	0.58
	ΔT	23	21	18	14	23	21	18	14	24	22	18	14	23	21	18	14	23	21	17	14	24	22	19	15
	KW	1.05	1.05	1.05	1.06	1.17	1.17	1.17	1.18	1.30	1.30	1.30	1.31	1.44	1.44	1.44	1.45	1.60	1.60	1.59	1.60	1.78	1.78	1.78	1.79
	Amps	3.9	3.9	3.9	3.9	4.4	4.4	4.4	4.5	5.0	5.0	5.0	5.1	5.7	5.7	5.7	5.7	6.4	6.4	6.4	6.4	7.2	7.2	7.2	7.3
	HI PR	241	242	244	248	279	280	282	286	318	319	321	325	360	361	363	367	406	407	409	413	455	456	457	462
LO PR	126	128	131	136	133	135	138	143	140	142	145	150	146	147	150	155	151	153	156	161	158	159	162	168	
75	675	18.7	19.0	19.5	20.3	18.5	18.8	19.3	20.2	18.1	18.3	18.9	19.7	17.3	17.5	18.1	18.9	16.3	16.5	17.1	17.9	15.4	15.6	16.2	17.0
	S/T	0.82	0.74	0.61	0.47	1.00	0.75	0.62	0.48	1.00	0.77	0.64	0.50	1.00	0.79	0.66	0.52	1.00	1.00	0.68	0.54	1.00	1.00	0.73	0.59
	ΔT	22	20	17	13	22	20	17	13	23	21	17	13	22	20	17	13	22	20	16	13	23	21	18	14
	KW	1.06	1.06	1.06	1.06	1.17	1.17	1.17	1.18	1.30	1.30	1.30	1.31	1.44	1.44	1.44	1.45	1.60	1.60	1.60	1.61	1.79	1.78	1.78	1.79
	Amps	3.9	3.9	3.9	4.0	4.5	4.5	4.4	4.5	5.1	5.0	5.0	5.1	5.7	5.7	5.7	5.7	6.4	6.4	6.4	6.4	7.3	7.3	7.3	7.3
	HI PR	244	245	246	250	281	282	284	288	320	321	323	327	363	364	365	369	408	409	411	415	457	458	460	464
LO PR	128	130	133	138	136	137	141	146	142	144	147	152	148	149	153	158	153	155	158	163	160	162	165	170	

IDB: Entering Indoor Dry Bulb Temperature
 High and low pressures are measured at the liquid and suction service valves.
 Shaded area reflects ACCA (TVA) conditions
 kW = Total system power
 Amps = outdoor unit amps (comp.-fan)

GSX140191K* + CA*F3636*6** + EEP + TXV (CONT.)

IDB		OUTDOOR AMBIENT TEMPERATURE												ENTERING INDOOR WET BULB TEMPERATURE											
		65				75				85				95				105				115			
		59	63	67	71	59	63	67	71	59	63	67	71	59	63	67	71	59	63	67	71	59	63	67	71
550	MBh	18.2	18.5	19.0	19.8	18.1	18.3	18.9	19.7	17.6	17.9	18.4	19.2	16.8	17.1	17.6	18.4	15.8	16.1	16.6	17.4	14.9	15.2	15.7	16.5
	S/T	1.00	0.82	0.69	0.6	1.00	0.83	0.69	0.56	1.00	0.85	0.72	0.6	1.00	1.00	0.74	0.60	1.00	1.00	0.76	0.6	1.00	1.00	0.81	0.67
	ΔT	28	26	23	19	28	26	23	19	29	27	23	19	28	26	23	19	28	26	22	19	29	27	24	20
	KW	1.05	1.05	1.05	1.1	1.17	1.17	1.16	1.17	1.30	1.30	1.29	1.3	1.44	1.44	1.43	1.44	1.59	1.59	1.59	1.6	1.78	1.78	1.77	1.78
	Amps	3.9	3.9	3.9	3.9	4.4	4.4	4.4	4.5	5.0	5.0	5.0	5.0	5.7	5.7	5.6	5.7	6.4	6.4	6.4	6.4	7.2	7.2	7.2	7.2
	HI PR	240	241	243	247	278	279	281	285	317	318	320	324	359	360	362	366	405	406	408	412	454	455	456	461
LO PR	125	127	130	135	133	134	137	142	139	141	144	149	145	146	149	155	150	152	155	160	157	158	162	167	
600	MBh	18.4	18.7	19.2	20.0	18.3	18.5	19.1	19.9	17.8	18.1	18.6	19.4	17.0	17.3	17.8	18.6	16.0	16.3	16.8	17.6	15.1	15.4	15.9	16.7
	S/T	1.00	0.85	0.72	0.6	1.00	0.85	0.72	0.58	1.00	0.88	0.75	0.6	1.00	1.00	0.76	0.63	1.00	1.00	0.79	0.7	1.00	1.00	0.84	0.70
	ΔT	28	26	22	18	28	26	22	18	28	26	22	19	28	26	22	18	27	25	22	18	28	27	23	19
	KW	1.05	1.05	1.05	1.1	1.17	1.17	1.17	1.18	1.30	1.30	1.30	1.3	1.44	1.44	1.44	1.45	1.60	1.60	1.59	1.6	1.78	1.78	1.78	1.79
	Amps	3.9	3.9	3.9	3.9	4.4	4.4	4.4	4.5	5.0	5.0	5.0	5.1	5.7	5.7	5.7	5.7	6.4	6.4	6.4	6.4	7.2	7.2	7.2	7.3
	HI PR	242	243	244	249	279	280	282	286	319	320	321	325	361	362	364	368	406	408	409	413	455	456	458	462
LO PR	127	128	131	136	134	136	139	144	141	142	145	150	146	148	151	156	152	153	156	161	158	160	163	168	
675	MBh	18.8	19.1	19.6	20.4	18.6	18.9	19.4	20.2	18.2	18.4	19.0	19.8	17.4	17.6	18.2	19.0	16.4	16.6	17.2	18.0	15.5	15.7	16.3	17.1
	S/T	1.00	0.86	0.73	0.6	1.00	0.87	0.74	0.60	1.00	0.89	0.76	0.6	1.00	1.00	0.78	0.64	1.00	1.00	0.80	0.7	1.00	1.00	0.85	0.71
	ΔT	27	25	21	17	27	25	21	17	27	25	21	18	27	25	21	17	26	24	21	17	28	26	22	18
	KW	1.06	1.06	1.06	1.1	1.18	1.17	1.17	1.18	1.30	1.30	1.30	1.3	1.45	1.44	1.44	1.45	1.60	1.60	1.60	1.6	1.79	1.78	1.78	1.79
	Amps	3.9	3.9	3.9	4.0	4.5	4.5	4.4	4.5	5.1	5.1	5.0	5.1	5.7	5.7	5.7	5.7	6.4	6.4	6.4	6.4	7.3	7.3	7.2	7.3
	HI PR	244	245	247	251	281	282	284	288	321	322	323	328	363	364	366	370	409	410	411	416	457	458	460	464
LO PR	129	130	134	139	136	138	141	146	143	144	148	153	149	150	153	158	154	155	159	164	161	162	165	171	
550	MBh	18.5	18.8	19.3	20.2	18.4	18.6	19.2	20.0	17.9	18.2	18.7	19.5	17.1	17.4	17.9	18.7	16.1	16.4	16.9	17.7	15.2	15.5	16.0	16.8
	S/T	1.00	0.92	0.79	0.65	1.00	1.00	0.79	0.65	1.00	1.00	0.82	0.68	1.00	1.00	0.84	0.71	1.00	1.00	0.86	0.72	1.00	1.00	1.00	0.77
	ΔT	32	30	27	23	32	30	27	23	32	30	27	23	32	30	27	23	32	30	26	23	33	31	27	24
	KW	1.05	1.05	1.05	1.06	1.17	1.17	1.17	1.17	1.30	1.30	1.30	1.30	1.44	1.44	1.44	1.44	1.60	1.59	1.59	1.60	1.78	1.78	1.78	1.79
	Amps	3.9	3.9	3.9	3.9	4.4	4.4	4.4	4.5	5.0	5.0	5.0	5.1	5.7	5.7	5.7	5.7	6.4	6.4	6.4	6.4	7.2	7.2	7.2	7.3
	HI PR	241	242	244	248	279	280	282	286	318	319	321	325	361	362	363	367	406	407	409	413	455	456	458	462
LO PR	127	128	132	137	134	136	139	144	141	143	146	151	147	148	151	156	152	153	157	162	159	160	163	169	
600	MBh	18.7	19.0	19.5	20.4	18.6	18.8	19.4	20.2	18.1	18.4	18.9	19.7	17.3	17.6	18.1	18.9	16.3	16.6	17.1	17.9	15.4	15.7	16.2	17.0
	S/T	1.00	0.95	0.81	0.67	1.00	1.00	0.82	0.68	1.00	1.00	0.84	0.71	1.00	1.00	0.86	0.72	1.00	1.00	0.88	0.75	1.00	1.00	1.00	0.80
	ΔT	31	29	26	22	31	29	26	22	32	30	26	22	31	29	26	22	31	29	26	22	32	30	27	23
	KW	1.06	1.06	1.05	1.06	1.17	1.17	1.17	1.18	1.30	1.30	1.30	1.31	1.44	1.44	1.44	1.45	1.60	1.60	1.60	1.61	1.78	1.78	1.78	1.79
	Amps	3.9	3.9	3.9	3.9	4.5	4.4	4.4	4.5	5.0	5.0	5.0	5.1	5.7	5.7	5.7	5.7	6.4	6.4	6.4	6.4	7.2	7.2	7.2	7.3
	HI PR	243	244	246	250	280	281	283	287	320	321	322	327	362	363	365	369	408	409	410	414	456	457	459	463
LO PR	128	130	133	138	136	137	141	146	142	144	147	152	148	149	153	158	153	155	158	163	160	162	165	170	
675	MBh	19.1	19.4	19.9	20.7	18.9	19.2	19.7	20.5	18.5	18.7	19.3	20.1	17.7	17.9	18.5	19.3	16.7	16.9	17.5	18.3	15.8	16.0	16.6	17.4
	S/T	1.00	0.96	0.83	0.69	1.00	1.00	0.84	0.70	1.00	1.00	0.86	0.72	1.00	1.00	0.88	0.74	1.00	1.00	0.90	0.76	1.00	1.00	1.00	0.81
	ΔT	30	28	25	21	30	28	25	21	31	29	25	21	30	28	25	21	30	28	25	21	31	29	26	22
	KW	1.06	1.06	1.06	1.07	1.18	1.18	1.17	1.18	1.31	1.31	1.30	1.31	1.45	1.45	1.44	1.45	1.60	1.60	1.60	1.61	1.79	1.79	1.79	1.79
	Amps	3.9	3.9	3.9	4.0	4.5	4.5	4.5	4.5	5.1	5.1	5.1	5.1	5.7	5.7	5.7	5.7	6.4	6.4	6.4	6.4	7.3	7.3	7.3	7.3
	HI PR	245	246	248	252	283	284	285	289	322	323	325	329	364	365	367	371	410	411	412	417	458	459	461	465
LO PR	131	132	135	141	138	140	143	148	145	146	149	155	150	152	155	160	156	157	160	166	163	164	167	172	

IDB: Entering Indoor Dry Bulb Temperature
 High and low pressures are measured at the liquid and suction service valves.
 Shaded area reflects AHRI conditions
 kW = Total system power
 Amps = outdoor unit amps (comp.-fan)

GSX140241K* + CA*F3636*6** + EEP

IDB		OUTDOOR AMBIENT TEMPERATURE												ENTERING INDOOR WET BULB TEMPERATURE											
		65				75				85				95				105				115			
		59	63	67	71	59	63	67	71	59	63	67	71	59	63	67	71	59	63	67	71	59	63	67	71
70	MBh	24.5	24.9	25.6	-	24.3	24.7	25.4	-	23.7	24.0	24.7	-	22.6	22.9	23.7	-	21.3	21.6	22.3	-	20.1	20.4	21.1	-
	S/T	0.63	0.56	0.43	-	0.63	0.56	0.43	-	0.66	0.59	0.46	-	0.68	0.60	0.48	-	1.00	0.62	0.50	-	1.00	0.67	0.55	-
	ΔT	20	18	15	-	20	18	15	-	21	19	15	-	20	18	15	-	20	18	14	-	21	19	16	-
	KW	1.41	1.40	1.40	-	1.57	1.57	1.57	-	1.75	1.75	1.75	-	1.95	1.95	1.95	-	2.17	2.17	2.17	-	2.43	2.43	2.43	-
	Amps	5.3	5.3	5.2	-	6.0	6.0	6.0	-	6.9	6.8	6.8	-	7.8	7.8	7.7	-	8.8	8.8	8.8	-	10.0	10.0	10.0	-
	HI PR	253	254	256	-	293	294	296	-	334	335	337	-	379	380	382	-	427	428	430	-	478	480	481	-
LO PR	121	123	126	-	128	130	133	-	135	136	139	-	140	142	145	-	145	147	150	-	152	153	156	-	
70	MBh	25.0	25.3	26.0	-	24.8	25.1	25.8	-	24.1	24.5	25.2	-	23.0	23.4	24.1	-	21.7	22.1	22.8	-	20.5	20.8	21.6	-
	S/T	0.66	0.59	0.46	-	0.67	0.60	0.47	-	0.69	0.62	0.49	-	0.71	0.64	0.51	-	1.00	0.66	0.53	-	1.00	0.71	0.58	-
	ΔT	19	17	14	-	19	17	13	-	19	17	14	-	19	17	13	-	19	17	13	-	20	18	14	-
	KW	1.41	1.41	1.41	-	1.58	1.58	1.57	-	1.76	1.76	1.76	-	1.96	1.96	1.96	-	2.18	2.18	2.18	-	2.44	2.44	2.44	-
	Amps	5.3	5.3	5.3	-	6.1	6.0	6.0	-	6.9	6.9	6.9	-	7.8	7.8	7.8	-	8.8	8.8	8.8	-	10.0	10.0	10.0	-
	HI PR	255	257	258	-	295	296	298	-	337	338	339	-	381	382	384	-	429	430	432	-	481	482	484	-
LO PR	123	125	128	-	131	132	135	-	137	138	141	-	142	144	147	-	148	149	152	-	154	156	159	-	
900	MBh	25.5	25.9	26.6	-	25.3	25.6	26.4	-	24.7	25.0	25.7	-	23.6	23.9	24.6	-	22.3	22.6	23.3	-	21.0	21.4	22.1	-
	S/T	0.67	0.60	0.47	-	0.68	0.60	0.48	-	0.70	0.63	0.50	-	1.00	0.65	0.52	-	1.00	0.67	0.54	-	1.00	0.72	0.59	-
	ΔT	18	16	13	-	18	16	12	-	18	16	13	-	18	16	12	-	18	16	12	-	19	17	13	-
	KW	1.42	1.42	1.42	-	1.59	1.58	1.58	-	1.77	1.77	1.76	-	1.97	1.97	1.96	-	2.19	2.19	2.19	-	2.45	2.45	2.45	-
	Amps	5.3	5.3	5.3	-	6.1	6.1	6.1	-	6.9	6.9	6.9	-	7.8	7.8	7.8	-	8.8	8.8	8.8	-	10.0	10.0	10.0	-
	HI PR	258	259	261	-	298	299	300	-	339	340	342	-	384	385	387	-	432	433	435	-	483	484	486	-
LO PR	126	127	130	-	133	135	138	-	140	141	144	-	145	146	149	-	150	152	155	-	157	158	161	-	
700	MBh	24.5	24.9	25.6	26.7	24.3	24.7	25.4	26.5	23.7	24.0	24.8	25.9	22.6	23.0	23.7	24.8	21.3	21.6	22.3	23.4	20.1	20.4	21.1	22.2
	S/T	0.75	0.68	0.55	0.42	0.76	0.68	0.56	0.42	1.00	0.71	0.58	0.44	1.00	0.73	0.60	0.46	1.00	0.75	0.62	0.48	1.00	0.80	0.67	0.53
	ΔT	25	23	19	15	25	23	19	15	25	23	19	15	25	23	19	15	24	22	19	15	26	24	20	16
	KW	1.40	1.40	1.40	1.41	1.57	1.57	1.56	1.58	1.75	1.75	1.75	1.76	1.95	1.95	1.95	1.96	2.17	2.17	2.17	2.18	2.43	2.43	2.43	2.44
	Amps	5.3	5.2	5.2	5.3	6.0	6.0	6.0	6.0	6.8	6.8	6.8	6.9	7.8	7.8	7.7	7.8	8.8	8.8	8.8	8.8	10.0	10.0	10.0	10.0
	HI PR	253	254	256	261	293	294	296	300	334	335	337	342	379	380	382	386	427	428	430	434	479	480	481	486
LO PR	121	123	126	131	128	130	133	138	135	136	139	144	140	142	145	150	145	147	150	155	152	153	157	162	
700	MBh	25.0	25.3	26.1	27.2	24.8	25.1	25.8	26.9	24.1	24.5	25.2	26.3	23.1	23.4	24.1	25.2	21.7	22.1	22.8	23.9	20.5	20.9	21.6	22.7
	S/T	0.78	0.71	0.58	0.45	0.79	0.72	0.59	0.46	1.00	0.74	0.61	0.48	1.00	0.76	0.63	0.50	1.00	0.78	0.65	0.52	1.00	1.00	0.70	0.57
	ΔT	24	22	18	14	24	22	18	14	24	22	18	14	24	22	18	14	23	21	18	14	25	23	19	15
	KW	1.41	1.41	1.41	1.42	1.58	1.58	1.57	1.59	1.76	1.76	1.76	1.77	1.96	1.96	1.96	1.97	2.18	2.18	2.18	2.19	2.44	2.44	2.44	2.45
	Amps	5.3	5.3	5.3	5.3	6.0	6.0	6.0	6.1	6.9	6.9	6.9	6.9	7.8	7.8	7.8	7.8	8.8	8.8	8.8	8.8	10.0	10.0	10.0	10.0
	HI PR	256	257	259	263	295	296	298	303	337	338	340	344	381	383	384	389	430	431	432	437	481	482	484	488
LO PR	123	125	128	133	131	132	135	140	137	138	141	147	142	144	147	152	148	149	152	157	154	156	159	164	
900	MBh	25.5	25.9	26.6	27.7	25.3	25.7	26.4	27.5	24.7	25.0	25.8	26.9	23.6	23.9	24.7	25.8	22.3	22.6	23.3	24.4	21.1	21.4	22.1	23.2
	S/T	0.79	0.72	0.59	0.46	1.00	0.73	0.60	0.46	1.00	0.75	0.62	0.49	1.00	0.77	0.64	0.51	1.00	0.79	0.66	0.53	1.00	1.00	0.71	0.57
	ΔT	23	21	17	13	23	21	17	13	23	21	17	13	23	21	17	13	22	20	17	13	24	22	18	14
	KW	1.42	1.42	1.42	1.43	1.58	1.58	1.58	1.59	1.77	1.77	1.76	1.78	1.97	1.96	1.96	1.97	2.19	2.19	2.18	2.20	2.45	2.45	2.44	2.46
	Amps	5.3	5.3	5.3	5.4	6.1	6.1	6.1	6.1	6.9	6.9	6.9	7.0	7.8	7.8	7.8	7.9	8.8	8.8	8.8	8.9	10.0	10.0	10.0	10.1
	HI PR	258	259	261	265	298	299	301	305	339	340	342	346	384	385	387	391	432	433	435	439	483	485	486	491
LO PR	126	127	130	136	133	135	138	143	140	141	144	149	145	146	149	155	150	152	155	160	157	158	161	166	

IDB: Entering Indoor Dry Bulb Temperature
 High and low pressures are measured at the liquid and suction service valves.
 Shaded area reflects ACCA (TVA) conditions
 kW = Total system power
 Amps = outdoor unit amps (comp.-fan)

GSX140241K* + CA*F3636*6** + EEP (CONT.)

IDB	Airflow	Outdoor Ambient Temperature																							
		65				75				85				95				105				115			
		59	63	67	71	59	63	67	71	59	63	67	71	59	63	67	71	59	63	67	71	59	63	67	71
700	MBh	24.0	24.4	25.1	26.2	23.8	24.2	24.9	26.0	23.2	23.6	24.3	25.3	22.2	22.5	23.2	24.3	20.9	21.2	21.9	23.0	19.7	20.0	20.7	21.8
	S/T	1.0	0.8	0.7	0.5	1.0	0.8	0.7	0.5	1.0	0.8	0.7	0.6	1.0	0.9	0.7	0.6	1.0	1.0	0.7	0.6	1.0	1.0	0.8	0.7
	ΔT	29	27	23	19	29	27	23	19	29	27	23	19	29	27	23	19	28	26	23	19	30	28	24	20
	kW	1.4	1.4	1.4	1.4	1.6	1.6	1.6	1.6	1.7	1.7	1.7	1.7	1.9	1.9	1.9	1.9	2.2	2.2	2.2	2.2	2.4	2.4	2.4	2.4
	Amps	5.2	5.2	5.2	5.2	5.9	5.9	5.9	6.0	6.7	6.7	6.7	6.8	7.6	7.6	7.6	7.7	8.6	8.6	8.6	8.7	9.8	9.8	9.8	9.9
	HI PR	255	256	258	262	294	296	297	302	336	337	339	343	381	382	384	388	429	430	432	437	481	482	484	488
LO PR	124	126	129	134	132	133	136	141	138	140	143	148	143	145	148	153	149	150	153	159	156	157	160	165	
800	MBh	24.5	24.8	25.5	26.6	24.3	24.6	25.3	26.4	23.7	24.0	24.7	25.8	22.6	22.9	23.6	24.7	21.3	21.6	22.3	23.4	20.1	20.4	21.2	22.2
	S/T	1.0	0.8	0.7	0.6	1.0	0.8	0.7	0.6	1.0	0.9	0.7	0.6	1.0	1.0	0.8	0.6	1.0	1.0	0.8	0.6	1.0	1.0	0.8	0.7
	ΔT	28	26	22	18	28	26	22	18	28	26	22	18	27	26	22	18	27	25	22	18	28	26	23	19
	kW	1.4	1.4	1.4	1.4	1.6	1.6	1.6	1.6	1.7	1.7	1.7	1.7	1.9	1.9	1.9	2.0	2.2	2.2	2.2	2.2	2.4	2.4	2.4	2.4
	Amps	5.2	5.2	5.2	5.3	6.0	5.9	5.9	6.0	6.8	6.8	6.8	6.8	7.7	7.7	7.7	7.7	8.7	8.7	8.7	8.7	9.9	9.8	9.8	9.9
	HI PR	257	258	260	264	297	298	300	304	338	340	341	346	383	384	386	391	432	433	435	439	483	484	486	490
LO PR	126	128	131	136	134	135	138	144	140	142	145	150	146	147	150	156	151	153	156	161	158	159	163	168	
900	MBh	25.0	25.3	26.1	27.1	24.8	25.1	25.8	26.9	24.2	24.5	25.2	26.3	23.1	23.5	24.2	25.2	21.8	22.2	22.9	23.9	20.6	21.0	21.7	22.8
	S/T	1.0	0.8	0.7	0.6	1.0	0.9	0.7	0.6	1.0	0.9	0.7	0.6	1.0	1.0	0.8	0.6	1.0	1.0	0.8	0.7	1.0	1.0	0.8	0.7
	ΔT	27	25	21	17	27	25	21	17	27	25	21	17	26	25	21	17	26	24	21	17	27	25	22	18
	kW	1.4	1.4	1.4	1.4	1.6	1.6	1.6	1.6	1.8	1.8	1.7	1.8	1.9	1.9	1.9	2.0	2.2	2.2	2.2	2.2	2.4	2.4	2.4	2.4
	Amps	5.2	5.2	5.2	5.3	6.0	6.0	6.0	6.0	6.8	6.8	6.8	6.9	7.7	7.7	7.7	7.7	8.7	8.7	8.7	8.7	9.9	9.9	9.9	9.9
	HI PR	260	261	262	267	299	300	302	307	341	342	344	348	386	387	389	393	434	435	437	441	486	487	489	493
LO PR	129	131	134	139	136	138	141	146	143	144	148	153	148	150	153	158	154	155	158	164	161	162	165	170	

IDB	Airflow	Outdoor Ambient Temperature																							
		65				75				85				95				105				115			
		59	63	67	71	59	63	67	71	59	63	67	71	59	63	67	71	59	63	67	71	59	63	67	71
700	MBh	24.4	24.8	25.5	26.6	24.2	24.6	25.3	26.4	23.6	24.0	24.7	25.7	22.6	22.9	23.6	24.7	21.3	21.6	22.3	23.4	20.1	20.4	21.1	22.2
	S/T	1.0	0.9	0.8	0.7	1.0	0.9	0.8	0.7	1.0	1.0	0.8	0.7	1.0	1.0	0.9	0.7	1.0	1.0	0.9	0.7	1.0	1.0	0.8	0.8
	ΔT	33	31	27	23	32	31	27	23	33	31	27	23	32	31	27	23	32	30	27	23	33	31	28	24
	kW	1.4	1.4	1.4	1.4	1.6	1.6	1.6	1.6	1.7	1.7	1.7	1.7	1.9	1.9	1.9	1.9	2.2	2.2	2.2	2.2	2.4	2.4	2.4	2.4
	Amps	5.2	5.2	5.2	5.2	5.9	5.9	5.9	6.0	6.8	6.8	6.7	6.8	7.7	7.6	7.6	7.7	8.7	8.7	8.6	8.7	9.8	9.8	9.8	9.9
	HI PR	256	257	259	263	296	297	299	303	337	338	340	345	382	383	385	389	430	432	433	438	482	483	485	489
LO PR	126	127	131	136	133	135	138	143	140	141	144	150	145	147	150	155	151	152	155	160	157	159	162	167	
800	MBh	24.9	25.2	25.9	27.0	24.7	25.0	25.7	26.8	24.1	24.4	25.1	26.2	23.0	23.3	24.0	25.1	21.7	22.0	22.7	23.8	20.5	20.8	21.5	22.6
	S/T	1.0	0.9	0.8	0.7	1.0	1.0	0.8	0.7	1.0	1.0	0.8	0.7	1.0	1.0	0.9	0.7	1.0	1.0	0.9	0.7	1.0	1.0	0.8	0.8
	ΔT	31	29	26	22	31	29	26	22	32	30	26	22	31	29	26	22	31	29	25	22	32	30	27	23
	kW	1.4	1.4	1.4	1.4	1.6	1.6	1.6	1.6	1.8	1.7	1.7	1.8	1.9	1.9	1.9	2.0	2.2	2.2	2.2	2.2	2.4	2.4	2.4	2.4
	Amps	5.2	5.2	5.2	5.3	6.0	6.0	6.0	6.0	6.8	6.8	6.8	6.8	7.7	7.7	7.7	7.7	8.7	8.7	8.7	8.7	9.9	9.9	9.8	9.9
	HI PR	258	259	261	266	298	299	301	305	340	341	343	347	384	386	387	392	433	434	436	440	484	486	487	492
LO PR	128	130	133	138	136	137	140	145	142	144	147	152	148	149	152	157	153	154	158	163	160	161	164	170	
900	MBh	25.4	25.7	26.4	27.5	25.2	25.5	26.2	27.3	24.6	24.9	25.6	26.7	23.5	23.9	24.6	25.6	22.2	22.6	23.3	24.3	21.0	21.4	22.1	23.2
	S/T	1.0	0.9	0.8	0.7	1.0	1.0	0.8	0.7	1.0	1.0	0.8	0.7	1.0	1.0	0.9	0.7	1.0	1.0	0.9	0.7	1.0	1.0	0.8	0.8
	ΔT	30	28	25	21	30	28	25	21	31	29	25	21	30	28	25	21	30	28	24	21	31	29	26	22
	kW	1.4	1.4	1.4	1.4	1.6	1.6	1.6	1.6	1.8	1.8	1.8	1.8	2.0	2.0	2.0	2.0	2.2	2.2	2.2	2.2	2.4	2.4	2.4	2.4
	Amps	5.3	5.3	5.2	5.3	6.0	6.0	6.0	6.0	6.8	6.8	6.8	6.9	7.7	7.7	7.7	7.8	8.7	8.7	8.7	8.8	9.9	9.9	9.9	9.9
	HI PR	261	262	264	268	300	302	303	308	342	343	345	349	387	388	390	394	435	436	438	443	487	488	490	494
LO PR	131	132	135	141	138	140	143	148	145	146	149	155	150	152	155	160	156	157	160	165	162	164	167	172	

IDB: Entering Indoor Dry Bulb Temperature
 High and low pressures are measured at the liquid and suction service valves.
 Shaded area reflects AHRI conditions
 kW = Total system power
 Amps = outdoor unit amps (comp.+fan)

GSX140251K* + CA*F3636*6** + EEP

IDB		OUTDOOR AMBIENT TEMPERATURE												ENTERING INDOOR WET BULB TEMPERATURE											
		65				75				85				95				105				115			
		59	63	67	71	59	63	67	71	59	63	67	71	59	63	67	71	59	63	67	71	59	63	67	71
70	MBh	24.5	24.9	25.6	-	24.3	24.7	25.4	-	23.7	24.0	24.7	-	22.6	22.9	23.7	-	21.3	21.6	22.3	-	20.1	20.4	21.1	-
	S/T	0.63	0.56	0.43	-	0.63	0.56	0.43	-	0.66	0.59	0.46	-	0.68	0.60	0.48	-	1.00	0.62	0.50	-	1.00	0.67	0.55	-
	ΔT	20	18	15	-	20	18	15	-	21	19	15	-	20	18	15	-	20	18	14	-	21	19	16	-
	KW	1.41	1.40	1.40	-	1.57	1.57	1.57	-	1.75	1.75	1.75	-	1.95	1.95	1.95	-	2.17	2.17	2.17	-	2.43	2.43	2.43	-
	Amps	5.3	5.3	5.2	-	6.0	6.0	6.0	-	6.9	6.8	6.8	-	7.8	7.8	7.7	-	8.8	8.8	8.8	-	10.0	10.0	10.0	-
	HI PR	253	254	256	-	293	294	296	-	334	335	337	-	379	380	382	-	427	428	430	-	478	480	481	-
	LO PR	121	123	126	-	128	130	133	-	135	136	139	-	140	142	145	-	145	147	150	-	152	153	156	-
	MBh	25.0	25.3	26.0	-	24.8	25.1	25.8	-	24.1	24.5	25.2	-	23.0	23.4	24.1	-	21.7	22.1	22.8	-	20.5	20.8	21.6	-
	S/T	0.66	0.59	0.46	-	0.67	0.60	0.47	-	0.69	0.62	0.49	-	0.71	0.64	0.51	-	1.00	0.66	0.53	-	1.00	0.71	0.58	-
	ΔT	19	17	14	-	19	17	13	-	19	17	14	-	19	17	13	-	19	17	13	-	20	18	14	-
	KW	1.41	1.41	1.41	-	1.58	1.58	1.57	-	1.76	1.76	1.76	-	1.96	1.96	1.96	-	2.18	2.18	2.18	-	2.44	2.44	2.44	-
	Amps	5.3	5.3	5.3	-	6.1	6.0	6.0	-	6.9	6.9	6.9	-	7.8	7.8	7.8	-	8.8	8.8	8.8	-	10.0	10.0	10.0	-
HI PR	255	257	258	-	295	296	298	-	337	338	339	-	381	382	384	-	429	430	432	-	481	482	484	-	
LO PR	123	125	128	-	131	132	135	-	137	138	141	-	142	144	147	-	148	149	152	-	154	156	159	-	
MBh	25.5	25.9	26.6	-	25.3	25.6	26.4	-	24.7	25.0	25.7	-	23.6	23.9	24.6	-	22.3	22.6	23.3	-	21.0	21.4	22.1	-	
S/T	0.67	0.60	0.47	-	0.68	0.60	0.48	-	0.70	0.63	0.50	-	1.00	0.65	0.52	-	1.00	0.67	0.54	-	1.00	0.72	0.59	-	
ΔT	18	16	13	-	18	16	12	-	18	16	13	-	18	16	12	-	18	16	12	-	19	17	13	-	
KW	1.42	1.42	1.42	-	1.59	1.58	1.58	-	1.77	1.77	1.76	-	1.97	1.97	1.96	-	2.19	2.19	2.19	-	2.45	2.45	2.45	-	
Amps	5.3	5.3	5.3	-	6.1	6.1	6.1	-	6.9	6.9	6.9	-	7.8	7.8	7.8	-	8.8	8.8	8.8	-	10.0	10.0	10.0	-	
HI PR	258	259	261	-	298	299	300	-	339	340	342	-	384	385	387	-	432	433	435	-	483	484	486	-	
LO PR	126	127	130	-	133	135	138	-	140	141	144	-	145	146	149	-	150	152	155	-	157	158	161	-	
75	MBh	24.5	24.9	25.6	26.7	24.3	24.7	25.4	26.5	23.7	24.0	24.8	25.9	22.6	23.0	23.7	24.8	21.3	21.6	22.3	23.4	20.1	20.4	21.1	22.2
	S/T	0.75	0.68	0.55	0.42	0.76	0.68	0.56	0.42	1.00	0.71	0.58	0.44	1.00	0.73	0.60	0.46	1.00	0.75	0.62	0.48	1.00	0.80	0.67	0.53
	ΔT	25	23	19	15	25	23	19	15	25	23	19	15	25	23	19	15	24	22	19	15	26	24	20	16
	KW	1.40	1.40	1.40	1.41	1.57	1.57	1.56	1.58	1.75	1.75	1.75	1.76	1.95	1.95	1.95	1.96	2.17	2.17	2.17	2.18	2.43	2.43	2.43	2.44
	Amps	5.3	5.2	5.2	5.3	6.0	6.0	6.0	6.0	6.8	6.8	6.8	6.9	7.8	7.8	7.7	7.8	8.8	8.8	8.8	8.8	10.0	10.0	10.0	10.0
	HI PR	253	254	256	261	293	294	296	300	334	335	337	342	379	380	382	386	427	428	430	434	479	480	481	486
	LO PR	121	123	126	131	128	130	133	138	135	136	139	144	140	142	145	150	145	147	150	155	152	153	157	162
	MBh	25.0	25.3	26.1	27.2	24.8	25.1	25.8	26.9	24.1	24.5	25.2	26.3	23.1	23.4	24.1	25.2	21.7	22.1	22.8	23.9	20.5	20.9	21.6	22.7
	S/T	0.78	0.71	0.58	0.45	0.79	0.72	0.59	0.46	1.00	0.74	0.61	0.48	1.00	0.76	0.63	0.50	1.00	0.78	0.65	0.52	1.00	1.00	0.70	0.57
	ΔT	24	22	18	14	24	22	18	14	24	22	18	14	24	22	18	14	23	21	18	14	25	23	19	15
	KW	1.41	1.41	1.41	1.42	1.58	1.58	1.57	1.59	1.76	1.76	1.76	1.77	1.96	1.96	1.96	1.97	2.18	2.18	2.18	2.19	2.44	2.44	2.44	2.45
	Amps	5.3	5.3	5.3	5.3	6.0	6.0	6.0	6.1	6.9	6.9	6.9	6.9	7.8	7.8	7.8	7.8	8.8	8.8	8.8	8.8	10.0	10.0	10.0	10.0
HI PR	256	257	259	263	295	296	298	303	337	338	340	344	381	383	384	389	430	431	432	437	481	482	484	488	
LO PR	123	125	128	133	131	132	135	140	137	138	141	147	142	144	147	152	148	149	152	157	154	156	159	164	
MBh	25.5	25.9	26.6	27.7	25.3	25.7	26.4	27.5	24.7	25.0	25.8	26.9	23.6	23.9	24.7	25.8	22.3	22.6	23.3	24.4	21.1	21.4	22.1	23.2	
S/T	0.79	0.72	0.59	0.46	1.00	0.73	0.60	0.46	1.00	0.75	0.62	0.49	1.00	0.77	0.64	0.51	1.00	0.79	0.66	0.53	1.00	1.00	0.71	0.57	
ΔT	23	21	17	13	23	21	17	13	23	21	17	13	23	21	17	13	22	20	17	13	24	22	18	14	
KW	1.42	1.42	1.42	1.43	1.58	1.58	1.58	1.59	1.77	1.77	1.76	1.78	1.97	1.96	1.96	1.97	2.19	2.19	2.18	2.20	2.45	2.45	2.44	2.46	
Amps	5.3	5.3	5.3	5.4	6.1	6.1	6.1	6.1	6.9	6.9	6.9	7.0	7.8	7.8	7.8	7.9	8.8	8.8	8.8	8.9	10.0	10.0	10.0	10.1	
HI PR	258	259	261	265	298	299	301	305	339	340	342	346	384	385	387	391	432	433	435	439	483	485	486	491	
LO PR	126	127	130	136	133	135	138	143	140	141	144	149	145	146	149	155	150	152	155	160	157	158	161	166	

IDB: Entering Indoor Dry Bulb Temperature
 High and low pressures are measured at the liquid and suction service valves.
 Shaded area reflects ACCA (TVA) conditions
 kW = Total system power
 Amps = outdoor unit amps (comp.-fan)

GSX140251K* + CA*F3636*6** + EEP (CONT.)

IDB		OUTDOOR AMBIENT TEMPERATURE												ENTERING INDOOR WET BULB TEMPERATURE											
		65				75				85				95				105				115			
		59	63	67	71	59	63	67	71	59	63	67	71	59	63	67	71	59	63	67	71	59	63	67	71
700	MBh	24.7	25.0	25.7	26.8	24.5	24.8	25.5	26.6	23.8	24.2	24.9	26.0	22.7	23.1	23.8	24.9	21.4	21.7	22.5	23.6	20.2	20.5	21.3	22.4
	S/T	0.87	0.80	0.67	0.5	1.00	0.80	0.67	0.54	1.00	0.83	0.70	0.6	1.00	0.84	0.72	0.58	1.00	1.00	0.74	0.6	1.00	1.00	0.79	0.65
	ΔT	29	27	23	20	29	27	23	20	29	27	24	20	29	27	23	20	29	27	23	19	30	28	24	21
	KW	1.41	1.40	1.40	1.4	1.57	1.57	1.57	1.58	1.75	1.75	1.75	1.8	1.95	1.95	1.95	1.96	2.17	2.17	2.17	2.2	2.43	2.43	2.43	2.44
	Amps	5.3	5.3	5.2	5.3	6.0	6.0	6.0	6.1	6.9	6.8	6.8	6.9	7.8	7.8	7.7	7.8	8.8	8.8	8.8	8.8	10.0	10.0	10.0	10.0
	HI PR	254	255	257	261	293	294	296	301	335	336	338	342	380	381	382	387	428	429	431	435	479	480	482	486
	LO PR	122	123	126	131	129	130	133	139	135	137	140	145	141	142	145	150	146	147	150	156	153	154	157	162
	MBh	25.1	25.5	26.2	27.3	24.9	25.2	26.0	27.1	24.3	24.6	25.3	26.4	23.2	23.5	24.2	25.3	21.8	22.2	22.9	24.0	20.6	21.0	21.7	22.8
	S/T	1.00	0.83	0.70	0.6	1.00	0.84	0.71	0.57	1.00	0.86	0.73	0.6	1.00	0.88	0.75	0.62	1.00	1.00	0.77	0.6	1.00	1.00	0.82	0.69
	ΔT	28	26	22	18	28	26	22	18	28	26	23	19	28	26	22	18	28	26	22	18	29	27	23	19
KW	1.41	1.41	1.41	1.4	1.58	1.58	1.57	1.59	1.76	1.76	1.76	1.8	1.96	1.96	1.96	1.97	2.18	2.18	2.18	2.2	2.44	2.44	2.44	2.45	
Amps	5.3	5.3	5.3	5.3	6.0	6.0	6.0	6.1	6.9	6.9	6.9	6.9	7.8	7.8	7.8	7.8	8.8	8.8	8.8	8.9	10.0	10.0	10.0	10.0	
HI PR	256	257	259	263	296	297	299	303	337	338	340	344	382	383	385	389	430	431	433	437	481	483	484	489	
LO PR	124	125	128	133	131	133	136	141	138	139	142	147	143	144	147	152	148	150	153	158	155	156	159	164	
MBh	25.7	26.0	26.7	27.8	25.4	25.8	26.5	27.6	24.8	25.2	25.9	27.0	23.7	24.1	24.8	25.9	22.4	22.7	23.5	24.6	21.2	21.5	22.2	23.3	
S/T	1.00	0.84	0.71	0.6	1.00	0.84	0.72	0.58	1.00	0.87	0.74	0.6	1.00	1.00	0.76	0.62	1.00	1.00	0.78	0.6	1.00	1.00	0.83	0.69	
ΔT	27	25	21	17	27	25	21	17	27	25	22	18	27	25	21	17	27	25	21	17	28	26	22	18	
KW	1.42	1.42	1.42	1.4	1.58	1.58	1.58	1.59	1.77	1.77	1.76	1.8	1.97	1.97	1.96	1.98	2.19	2.19	2.19	2.2	2.45	2.45	2.45	2.46	
Amps	5.3	5.3	5.3	5.4	6.1	6.1	6.1	6.1	6.9	6.9	6.9	7.0	7.8	7.8	7.8	7.9	8.8	8.8	8.8	8.9	10.0	10.0	10.0	10.1	
HI PR	259	260	261	266	298	299	301	305	340	341	343	347	384	385	387	392	433	434	435	440	484	485	487	491	
LO PR	126	128	131	136	134	135	138	143	140	142	145	150	145	147	150	155	151	152	155	160	157	159	162	167	
800	MBh	25.1	25.4	26.1	27.2	24.9	25.2	25.9	27.0	24.2	24.6	25.3	26.4	23.1	23.5	24.2	25.3	21.8	22.2	22.9	24.0	20.6	20.9	21.7	22.8
	S/T	1.00	0.89	0.76	0.63	1.00	0.90	0.77	0.63	1.00	1.00	0.79	0.66	1.00	1.00	0.81	0.68	1.00	1.00	0.83	0.70	1.00	1.00	1.00	0.75
	ΔT	33	31	27	24	33	31	27	23	33	31	28	24	33	31	27	23	33	31	27	23	34	32	28	24
	KW	1.41	1.41	1.40	1.42	1.57	1.57	1.57	1.58	1.76	1.76	1.75	1.76	1.96	1.95	1.95	1.96	2.18	2.18	2.17	2.19	2.44	2.44	2.43	2.45
	Amps	5.3	5.3	5.3	5.3	6.0	6.0	6.0	6.1	6.9	6.9	6.8	6.9	7.8	7.8	7.8	7.8	8.8	8.8	8.8	8.8	10.0	10.0	10.0	10.0
	HI PR	255	256	258	262	295	296	297	302	336	337	339	343	381	382	384	388	429	430	432	436	480	481	483	488
	LO PR	123	125	128	133	131	132	135	140	137	139	142	147	142	144	147	152	148	149	152	157	154	156	159	164
	MBh	25.5	25.9	26.6	27.7	25.3	25.6	26.4	27.5	24.7	25.0	25.7	26.8	23.6	23.9	24.7	25.8	22.3	22.6	23.3	24.4	21.0	21.4	22.1	23.2
	S/T	1.00	0.93	0.80	0.66	1.00	0.93	0.80	0.67	1.00	1.00	0.83	0.69	1.00	1.00	0.85	0.71	1.00	1.00	0.87	0.73	1.00	1.00	1.00	0.78
	ΔT	32	30	26	22	32	30	26	22	32	30	26	23	32	30	26	22	32	30	26	22	33	31	27	23
KW	1.42	1.42	1.41	1.42	1.58	1.58	1.58	1.59	1.76	1.76	1.76	1.77	1.96	1.96	1.96	1.97	2.19	2.18	2.18	2.19	2.45	2.44	2.44	2.45	
Amps	5.3	5.3	5.3	5.3	6.1	6.1	6.0	6.1	6.9	6.9	6.9	6.9	7.8	7.8	7.8	7.9	8.8	8.8	8.8	8.9	10.0	10.0	10.0	10.1	
HI PR	257	258	260	265	297	298	300	304	338	339	341	346	383	384	386	390	431	432	434	438	483	484	485	490	
LO PR	126	127	130	135	133	134	137	143	139	141	144	149	145	146	149	154	150	151	154	160	157	158	161	166	
MBh	26.1	26.4	27.1	28.2	25.9	26.2	26.9	28.0	25.2	25.6	26.3	27.4	24.1	24.5	25.2	26.3	22.8	23.1	23.9	25.0	21.6	21.9	22.7	23.8	
S/T	1.00	0.93	0.81	0.67	1.00	1.00	0.81	0.68	1.00	1.00	0.84	0.70	1.00	1.00	0.85	0.72	1.00	1.00	0.87	0.74	1.00	1.00	1.00	0.79	
ΔT	31	29	25	21	31	29	25	21	31	29	25	22	31	29	25	21	31	29	25	21	32	30	26	22	
KW	1.42	1.42	1.42	1.43	1.59	1.59	1.58	1.60	1.77	1.77	1.77	1.78	1.97	1.97	1.97	1.98	2.19	2.19	2.19	2.20	2.45	2.45	2.45	2.46	
Amps	5.3	5.3	5.3	5.4	6.1	6.1	6.1	6.1	6.9	6.9	6.9	7.0	7.8	7.8	7.8	7.9	8.9	8.9	8.8	8.9	10.1	10.0	10.0	10.1	
HI PR	260	261	263	267	299	300	302	307	341	342	344	348	386	387	388	393	434	435	437	441	485	486	488	492	
LO PR	128	130	133	138	136	137	140	145	142	143	146	151	147	149	152	157	153	154	157	162	159	161	164	169	

kW = Total system power
Amps = outdoor unit amps (comp.-fan)

Shaded area reflects AHRI conditions

IDB: Entering Indoor Dry Bulb Temperature
High and low pressures are measured at the liquid and suction service valves.

GSX140301K* + CA*F3642*6** + EEP

IDB		OUTDOOR AMBIENT TEMPERATURE												ENTERING INDOOR WET BULB TEMPERATURE												ENTERING INDOOR DRY BULB TEMPERATURE											
		65				75				85				95				105				115															
		59	63	67	71	59	63	67	71	59	63	67	71	59	63	67	71	59	63	67	71	59	63	67	71	59	63	67	71								
70	MBh	29.3	29.7	30.6	31.9	29.0	29.5	30.3	31.7	28.3	28.7	29.6	30.9	27.0	27.4	28.2	29.6	25.3	25.8	26.6	28.0	23.9	24.3	25.2	26.6	23.9	24.3	25.2	26.6								
	S/T	0.59	0.52	0.38	-	0.60	0.52	0.39	-	0.62	0.55	0.42	-	1.00	0.57	0.43	-	1.00	0.59	0.46	-	1.00	0.64	0.51	-	1.00	0.64	0.51	-								
	ΔT	20	18	15	-	20	18	15	-	20	18	15	-	20	18	15	-	20	18	14	-	21	19	15	-	21	19	15	-								
	KW	1.76	1.75	1.75	-	1.95	1.95	1.95	-	2.17	2.17	2.17	-	2.41	2.41	2.41	-	2.68	2.68	2.67	-	2.99	2.99	2.99	-	2.99	2.99	2.99	-								
	Amps	6.4	6.4	6.4	-	7.3	7.3	7.3	-	8.3	8.3	8.3	-	9.4	9.4	9.4	-	10.6	10.6	10.6	-	12.0	12.0	12.0	-	12.0	12.0	12.0	-								
	HI PR	250	251	252	-	289	290	292	-	330	331	333	-	375	376	377	-	422	424	425	-	474	475	476	-	474	475	476	-								
LO PR	124	125	128	-	131	133	136	-	138	139	142	-	143	145	148	-	149	150	154	-	156	157	160	-	156	157	160	-									
70	MBh	29.7	30.1	31.0	-	29.4	29.8	30.7	-	28.7	29.1	29.9	-	27.3	27.8	28.6	-	25.7	26.1	27.0	-	24.3	24.7	25.6	-	24.3	24.7	25.6	-								
	S/T	0.65	0.58	0.44	-	0.66	0.58	0.45	-	0.68	0.61	0.47	-	1.00	0.63	0.49	-	1.00	0.65	0.51	-	1.00	0.70	0.56	-	1.00	0.70	0.56	-								
	ΔT	19	17	13	-	19	17	13	-	19	17	14	-	19	17	13	-	18	17	13	-	20	18	14	-	20	18	14	-								
	KW	1.77	1.77	1.76	-	1.96	1.96	1.96	-	2.18	2.18	2.18	-	2.42	2.42	2.42	-	2.69	2.69	2.68	-	3.00	3.00	3.00	-	3.00	3.00	3.00	-								
	Amps	6.4	6.4	6.4	-	7.3	7.3	7.3	-	8.3	8.3	8.3	-	9.4	9.4	9.4	-	10.6	10.6	10.6	-	12.1	12.1	12.1	-	12.1	12.1	12.1	-								
	HI PR	252	253	254	-	291	292	294	-	332	333	335	-	377	378	379	-	425	426	427	-	476	477	478	-	476	477	478	-								
LO PR	125	127	130	-	133	135	138	-	140	141	144	-	145	147	150	-	151	152	155	-	157	159	162	-	157	159	162	-									
1125	MBh	30.1	30.6	31.4	-	29.9	30.3	31.2	-	29.1	29.5	30.4	-	27.8	28.2	29.1	-	26.2	26.6	27.5	-	24.7	25.1	26.0	-	24.7	25.1	26.0	-								
	S/T	0.68	0.61	0.48	-	0.69	0.61	0.48	-	0.71	0.64	0.51	-	1.00	0.66	0.53	-	1.00	0.68	0.55	-	1.00	0.73	0.60	-	1.00	0.73	0.60	-								
	ΔT	18	16	13	-	18	16	12	-	18	16	13	-	18	16	12	-	17	16	12	-	19	17	13	-	19	17	13	-								
	KW	1.78	1.77	1.77	-	1.97	1.97	1.97	-	2.19	2.19	2.19	-	2.43	2.43	2.43	-	2.70	2.70	2.69	-	3.01	3.01	3.01	-	3.01	3.01	3.01	-								
	Amps	6.5	6.5	6.4	-	7.4	7.4	7.3	-	8.4	8.4	8.3	-	9.5	9.5	9.4	-	10.7	10.7	10.7	-	12.1	12.1	12.1	-	12.1	12.1	12.1	-								
	HI PR	254	255	257	-	293	294	296	-	334	335	337	-	379	380	382	-	427	428	429	-	478	479	481	-	478	479	481	-								
LO PR	128	129	132	-	135	137	140	-	142	143	146	-	147	149	152	-	153	154	157	-	160	161	164	-	160	161	164	-									
75	MBh	29.3	29.7	30.6	31.9	29.1	29.5	30.3	31.7	28.3	28.7	29.6	30.9	27.0	27.4	28.3	29.6	25.4	25.8	26.7	28.0	23.9	24.3	25.2	26.5	23.9	24.3	25.2	26.5								
	S/T	0.72	0.64	0.51	0.37	0.72	0.65	0.52	0.38	1.00	0.67	0.54	0.40	1.00	0.69	0.56	0.42	1.00	0.71	0.58	0.44	1.00	1.00	0.63	0.49	1.00	1.00	0.63	0.49								
	ΔT	24	22	19	15	24	22	19	15	24	22	19	15	24	22	19	15	24	22	18	15	25	23	19	16	25	23	19	16								
	KW	1.76	1.75	1.75	1.77	1.95	1.95	1.95	1.96	2.17	2.17	2.17	2.18	2.41	2.41	2.41	2.42	2.68	2.68	2.67	2.69	2.99	2.99	2.99	3.00	2.99	2.99	2.99	3.00								
	Amps	6.4	6.4	6.3	6.4	7.3	7.3	7.2	7.3	8.3	8.3	8.3	8.3	9.4	9.4	9.3	9.4	10.6	10.6	10.6	10.6	12.0	12.0	12.0	12.1	12.0	12.0	12.0	12.1								
	HI PR	250	251	253	257	289	290	292	296	330	331	333	338	375	376	378	382	423	424	425	430	474	475	477	481	474	475	477	481								
LO PR	124	125	128	134	131	133	136	141	138	139	142	148	143	145	148	153	149	150	154	159	156	157	160	166	156	157	160	166									
75	MBh	29.7	30.1	31.0	32.3	29.4	29.9	30.7	32.1	28.7	29.1	30.0	31.3	27.4	27.8	28.6	30.0	25.8	26.2	27.0	28.4	24.3	24.7	25.6	26.9	24.3	24.7	25.6	26.9								
	S/T	0.78	0.70	0.57	0.43	0.78	0.71	0.58	0.44	1.00	0.73	0.60	0.46	1.00	0.75	0.62	0.48	1.00	0.77	0.64	0.50	1.00	1.00	0.69	0.55	1.00	1.00	0.69	0.55								
	ΔT	23	21	17	14	23	21	17	14	23	21	18	14	23	21	17	14	22	21	17	14	24	22	18	15	24	22	18	15								
	KW	1.77	1.76	1.76	1.78	1.96	1.96	1.96	1.97	2.18	2.18	2.18	2.19	2.42	2.42	2.42	2.43	2.69	2.69	2.68	2.70	3.00	3.00	3.00	3.01	3.00	3.00	3.00	3.01								
	Amps	6.4	6.4	6.4	6.5	7.3	7.3	7.3	7.4	8.3	8.3	8.3	8.4	9.4	9.4	9.4	9.5	10.6	10.6	10.6	10.7	12.1	12.1	12.1	12.1	12.1	12.1	12.1	12.1								
	HI PR	252	253	255	259	291	292	294	298	332	334	335	340	377	378	380	384	425	426	428	432	476	477	479	483	476	477	479	483								
LO PR	126	127	130	135	133	135	138	143	140	141	144	150	145	147	150	155	151	152	155	161	158	159	162	167	158	159	162	167									
1125	MBh	30.2	30.6	31.5	32.8	29.9	30.3	31.2	32.5	29.1	29.6	30.4	31.8	27.8	28.2	29.1	30.4	26.2	26.6	27.5	28.8	24.7	25.2	26.0	27.4	24.7	25.2	26.0	27.4								
	S/T	0.81	0.73	0.60	0.46	1.00	0.74	0.61	0.47	1.00	0.77	0.63	0.49	1.00	0.78	0.65	0.51	1.00	0.81	0.67	0.53	1.00	1.00	0.72	0.58	1.00	1.00	0.72	0.58								
	ΔT	22	20	17	13	22	20	17	13	22	20	17	13	22	20	16	13	21	20	16	13	23	21	17	14	23	21	17	14								
	KW	1.77	1.77	1.77	1.78	1.97	1.97	1.97	1.98	2.19	2.19	2.19	2.20	2.43	2.43	2.43	2.44	2.70	2.70	2.69	2.71	3.01	3.01	3.00	3.02	3.01	3.01	3.00	3.02								
	Amps	6.5	6.4	6.4	6.5	7.4	7.4	7.3	7.4	8.4	8.4	8.3	8.4	9.5	9.5	9.4	9.5	10.7	10.7	10.7	10.7	12.1	12.1	12.1	12.2	12.1	12.1	12.1	12.2								
	HI PR	254	255	257	261	293	294	296	300	335	336	337	342	379	380	382	386	427	428	430	434	478	479	481	485	478	479	481	485								
LO PR	128	129	132	137	135	137	140	145	142	143	146	152	147	149	152	157	153	154	157	163	160	161	164	169	160	161	164	169									

IDB: Entering Indoor Dry Bulb Temperature
 High and low pressures are measured at the liquid and suction service valves.
 Shaded area reflects ACCA (TVA) conditions
 kW = Total system power
 Amps = outdoor unit amps (comp.+fan)

GSX140301K* + CA*F3642*6** + EEP (CONT.)

		OUTDOOR AMBIENT TEMPERATURE												ENTERING INDOOR WET BULB TEMPERATURE															
		65				75				85				95				105				115							
IDB	AIRFLOW	59	63	67	71	59	63	67	71	59	63	67	71	59	63	67	71	59	63	67	71	59	63	67	71	59	63	67	71
80	875	MBh	29.5	29.9	30.8	32.1	29.2	29.6	30.5	31.8	28.4	28.9	29.7	31.1	27.1	27.5	28.4	29.8	25.5	25.9	26.8	28.1	24.0	24.5	25.3	26.7			
		S/T	1.00	0.77	0.63	0.5	1.00	0.77	0.64	0.50	1.00	0.80	0.66	0.5	1.00	1.00	0.68	0.54	1.00	1.00	0.70	0.6	1.00	1.00	0.75	0.61			
	ΔT	28	26	23	19	28	26	23	19	28	26	23	19	28	26	23	19	28	26	22	19	29	27	23	20				
	KW	1.76	1.75	1.75	1.8	1.95	1.95	1.95	1.96	2.17	2.17	2.17	2.2	2.41	2.41	2.41	2.42	2.68	2.68	2.67	2.7	2.99	2.99	2.99	3.00				
	Amps	6.4	6.4	6.3	6.4	7.3	7.3	7.3	7.3	8.3	8.3	8.3	8.3	9.4	9.4	9.4	9.4	10.6	10.6	10.6	10.6	12.0	12.0	12.0	12.1				
	HI PR	250	251	253	257	290	291	292	297	331	332	334	338	375	376	378	382	424	424	426	430	474	475	477	481				
	LO PR	124	126	129	134	132	133	136	142	138	140	143	148	144	145	149	154	149	151	154	159	156	158	161	166				
	MBh	29.9	30.3	31.1	32.5	29.6	30.0	30.9	32.2	28.8	29.2	30.1	31.5	27.5	27.9	28.8	30.1	25.9	26.3	27.2	28.5	24.4	24.8	25.7	27.1				
	S/T	1.00	0.82	0.69	0.6	1.00	0.83	0.70	0.56	1.00	0.85	0.72	0.6	1.00	1.00	0.74	0.60	1.00	1.00	0.76	0.6	1.00	1.00	0.81	0.67				
	ΔT	27	25	22	18	27	25	21	18	27	25	21	18	27	25	21	18	26	25	21	18	28	26	22	19				
KW	1.77	1.76	1.76	1.8	1.96	1.96	1.96	1.97	2.18	2.18	2.18	2.2	2.42	2.42	2.42	2.43	2.69	2.69	2.68	2.7	3.00	3.00	3.00	3.01					
Amps	6.4	6.4	6.4	6.5	7.3	7.3	7.3	7.4	8.3	8.3	8.3	8.4	9.4	9.4	9.4	9.5	10.6	10.6	10.6	10.7	12.1	12.1	12.1	12.1					
HI PR	252	253	255	259	292	293	295	299	333	334	336	340	377	378	380	385	425	426	428	432	476	477	479	484					
LO PR	126	128	131	136	134	135	138	144	140	142	145	150	146	147	150	156	151	153	156	161	158	160	163	168					
MBh	30.3	30.7	31.6	32.9	30.1	30.5	31.3	32.7	29.3	29.7	30.6	31.9	28.0	28.4	29.3	30.6	26.4	26.8	27.7	29.0	24.9	25.3	26.2	27.5					
S/T	1.00	0.86	0.72	0.6	1.00	0.86	0.73	0.59	1.00	0.89	0.76	0.6	1.00	1.00	0.77	0.63	1.00	1.00	0.80	0.7	1.00	1.00	0.85	0.71					
ΔT	26	24	21	17	26	24	21	17	26	24	21	17	26	24	21	17	26	24	20	17	27	25	21	18					
KW	1.78	1.77	1.77	1.8	1.97	1.97	1.97	1.98	2.19	2.19	2.19	2.2	2.43	2.43	2.43	2.44	2.70	2.70	2.69	2.7	3.01	3.01	3.01	3.02					
Amps	6.5	6.5	6.4	6.5	7.4	7.4	7.3	7.4	8.4	8.4	8.3	8.4	9.5	9.5	9.4	9.5	10.7	10.7	10.7	10.7	12.1	12.1	12.1	12.2					
HI PR	254	255	257	262	294	295	297	301	335	336	338	342	379	380	382	387	427	428	430	434	478	479	481	486					
LO PR	128	130	133	138	136	137	140	146	142	144	147	152	148	149	152	158	153	155	158	163	160	162	165	170					
85	875	MBh	30.0	30.4	31.3	32.6	29.7	30.1	31.0	32.3	28.9	29.3	30.2	31.6	27.6	28.0	28.9	30.2	26.0	26.4	27.3	28.6	24.5	25.0	25.8	27.2			
		S/T	1.00	0.86	0.73	0.59	1.00	0.87	0.74	0.60	1.00	1.00	0.76	0.62	1.00	1.00	0.78	0.64	1.00	1.00	0.80	0.66	1.00	1.00	1.00	0.71			
	ΔT	31	30	26	23	31	30	26	23	32	30	26	23	31	30	26	23	31	29	26	22	32	30	27	24				
	KW	1.76	1.76	1.76	1.77	1.96	1.96	1.95	1.97	2.18	2.18	2.17	2.19	2.42	2.41	2.41	2.43	2.68	2.68	2.68	2.69	3.00	2.99	2.99	3.01				
	Amps	6.4	6.4	6.4	6.4	7.3	7.3	7.3	7.3	8.3	8.3	8.3	8.3	9.4	9.4	9.4	9.4	10.6	10.6	10.6	10.7	12.0	12.0	12.0	12.1				
	HI PR	251	252	254	259	291	292	294	298	332	333	335	339	376	377	379	384	424	425	427	431	475	476	478	483				
	LO PR	126	128	131	136	134	135	138	144	140	142	145	150	146	147	150	156	151	153	156	161	158	160	163	168				
	MBh	30.0	31.0	32.0	33.0	30.0	30.0	31.0	33.0	29.0	30.0	31.0	32.0	28.0	28.0	29.0	31.0	26.0	27.0	28.0	29.0	25.0	25.0	26.0	28.0				
	S/T	1.00	0.92	0.79	0.65	1.00	1.00	0.80	0.66	1.00	1.00	0.82	0.68	1.00	1.00	0.84	0.70	1.00	1.00	0.86	0.72	1.00	1.00	1.00	0.77				
	ΔT	30	29	25	22	30	29	25	22	31	29	25	22	30	28	25	22	30	28	25	21	31	29	26	22				
KW	1.77	1.77	1.77	1.78	1.97	1.97	1.96	1.98	2.19	2.19	2.18	2.20	2.43	2.42	2.42	2.44	2.69	2.69	2.69	2.70	3.01	3.00	3.00	3.02					
Amps	6.4	6.4	6.4	6.5	7.3	7.3	7.3	7.4	8.3	8.3	8.3	8.4	9.4	9.4	9.4	9.5	10.7	10.7	10.6	10.7	12.1	12.1	12.1	12.1					
HI PR	253	255	256	261	293	294	296	300	334	335	337	341	379	380	381	386	426	427	429	434	477	479	480	485					
LO PR	128	129	133	138	135	137	140	145	142	144	147	152	148	149	152	158	153	155	158	163	160	161	165	170					
MBh	31.0	31.0	32.0	33.0	31.0	31.0	32.0	33.0	30.0	30.0	31.0	32.0	28.0	29.0	30.0	31.0	27.0	27.0	28.0	29.0	25.0	26.0	27.0	28.0					
S/T	1.00	0.96	0.82	0.68	1.00	1.00	0.83	0.69	1.00	1.00	0.85	0.71	1.00	1.00	0.87	0.73	1.00	1.00	1.00	0.76	1.00	1.00	1.00	0.81					
ΔT	29	28	24	21	29	28	24	21	30	28	24	21	29	28	24	21	29	27	24	20	30	28	25	22					
KW	1.78	1.78	1.77	1.79	1.98	1.97	1.97	1.99	2.20	2.20	2.19	2.21	2.44	2.43	2.43	2.45	2.70	2.70	2.70	2.71	3.01	3.01	3.01	3.02					
Amps	6.5	6.5	6.5	6.5	7.4	7.4	7.4	7.4	8.4	8.4	8.4	8.4	9.5	9.5	9.5	9.5	10.7	10.7	10.7	10.7	12.1	12.1	12.1	12.2					
HI PR	256	257	258	263	295	296	298	302	336	337	339	343	381	382	383	388	428	430	431	436	480	481	482	487					
LO PR	130	131	135	140	137	139	142	147	144	146	149	154	150	151	154	160	155	157	160	165	162	163	167	172					

IDB: Entering Indoor Dry Bulb Temperature
 High and low pressures are measured at the liquid and suction service valves.
 Shaded area reflects AHRI conditions
 kW = Total system power
 Amps = outdoor unit amps (comp.+fan)

GSX140311K* + CA*F3137*6** + EEP

IDB		OUTDOOR AMBIENT TEMPERATURE												ENTERING INDOOR WET BULB TEMPERATURE											
		65				75				85				95				105				115			
		59	63	67	71	59	63	67	71	59	63	67	71	59	63	67	71	59	63	67	71	59	63	67	71
70	MBh	29.1	29.5	30.4	-	28.8	29.2	30.1	-	28.1	28.5	29.4	-	26.8	27.2	28.0	-	25.2	25.6	26.5	-	23.7	24.1	25.0	-
	S/T	0.63	0.55	0.41	-	0.63	0.56	0.42	-	0.66	0.58	0.44	-	0.68	0.60	0.46	-	1.00	0.62	0.48	-	1.00	0.68	0.54	-
	ΔT	20	18	15	-	20	18	15	-	20	19	15	-	20	18	15	-	20	18	15	-	21	19	16	-
	KW	1.72	1.72	1.72	-	1.91	1.91	1.91	-	2.13	2.12	2.12	-	2.36	2.35	2.35	-	2.61	2.61	2.61	-	2.92	2.92	2.91	-
	Amps	6.2	6.2	6.2	-	7.1	7.1	7.1	-	8.1	8.0	8.0	-	9.1	9.1	9.1	-	10.3	10.3	10.3	-	11.7	11.7	11.7	-
	HI PR	244	245	247	-	282	283	285	-	323	324	325	-	366	367	369	-	413	414	416	-	463	464	466	-
LO PR	123	124	127	-	130	132	135	-	137	138	141	-	142	144	147	-	148	149	152	-	154	156	159	-	
875	MBh	29.5	29.9	30.8	-	29.2	29.6	30.5	-	28.5	28.9	29.7	-	27.2	27.6	28.4	-	25.6	26.0	26.8	-	24.1	24.5	25.4	-
	S/T	0.69	0.61	0.47	-	0.70	0.62	0.48	-	0.72	0.64	0.50	-	1.00	0.66	0.52	-	1.00	0.69	0.55	-	1.00	0.74	0.60	-
	ΔT	19	17	14	-	19	17	14	-	19	17	14	-	19	17	14	-	19	17	13	-	20	18	15	-
	KW	1.73	1.73	1.73	-	1.92	1.92	1.92	-	2.14	2.13	2.13	-	2.37	2.36	2.36	-	2.62	2.62	2.62	-	2.93	2.93	2.92	-
	Amps	6.2	6.2	6.2	-	7.1	7.1	7.1	-	8.1	8.1	8.1	-	9.2	9.2	9.1	-	10.3	10.3	10.3	-	11.7	11.7	11.7	-
	HI PR	246	247	249	-	284	286	287	-	325	326	328	-	368	369	371	-	415	416	418	-	465	466	468	-
LO PR	124	126	129	-	132	133	136	-	138	140	143	-	144	145	149	-	149	151	154	-	156	158	161	-	
1000	MBh	29.9	30.3	31.2	-	29.7	30.1	31.0	-	28.9	29.3	30.2	-	27.6	28.0	28.9	-	26.0	26.4	27.3	-	24.6	25.0	25.8	-
	S/T	0.73	0.65	0.51	-	0.73	0.65	0.51	-	0.76	0.68	0.54	-	1.00	0.70	0.56	-	1.00	0.72	0.58	-	1.00	0.78	0.63	-
	ΔT	18	16	13	-	18	16	13	-	18	16	13	-	18	16	13	-	18	16	12	-	19	17	14	-
	KW	1.74	1.74	1.73	-	1.93	1.93	1.92	-	2.14	2.14	2.14	-	2.37	2.37	2.37	-	2.63	2.63	2.63	-	2.94	2.93	2.93	-
	Amps	6.3	6.3	6.3	-	7.2	7.2	7.1	-	8.1	8.1	8.1	-	9.2	9.2	9.2	-	10.4	10.4	10.4	-	11.8	11.8	11.7	-
	HI PR	248	249	251	-	286	288	289	-	327	328	330	-	370	371	373	-	417	418	420	-	467	468	470	-
LO PR	126	128	131	-	134	135	138	-	140	142	145	-	146	147	151	-	151	153	156	-	158	160	163	-	
1125	MBh	29.1	29.5	30.4	31.7	28.9	29.3	30.1	31.5	28.1	28.5	29.4	30.7	26.8	27.2	28.1	29.4	25.2	25.6	26.5	27.8	23.7	24.1	25.0	26.3
	S/T	0.76	0.68	0.54	0.39	0.77	0.69	0.55	0.40	1.00	0.72	0.57	0.43	1.00	0.74	0.60	0.45	1.00	0.76	0.62	0.47	1.00	1.00	0.67	0.52
	ΔT	24	22	19	15	24	22	19	15	25	23	19	16	24	22	19	15	24	22	19	15	25	23	20	16
	KW	1.72	1.72	1.71	1.73	1.91	1.91	1.91	1.92	2.12	2.12	2.12	2.13	2.36	2.35	2.35	2.36	2.61	2.61	2.61	2.62	2.92	2.92	2.91	2.93
	Amps	6.2	6.2	6.2	6.2	7.1	7.1	7.1	7.1	8.0	8.0	8.0	8.1	9.1	9.1	9.1	9.2	10.3	10.3	10.3	10.3	11.7	11.7	11.7	11.7
	HI PR	244	245	247	251	283	284	285	290	323	324	326	330	366	367	369	373	413	414	416	420	463	464	466	470
LO PR	123	124	127	132	130	132	135	140	137	138	141	146	142	144	147	152	148	149	152	157	154	156	159	164	
75	MBh	29.5	29.9	30.8	32.1	29.2	29.6	30.5	31.8	28.5	28.9	29.8	31.1	27.2	27.6	28.4	29.8	25.6	26.0	26.9	28.2	24.1	24.5	25.4	26.7
	S/T	0.82	0.75	0.60	0.46	0.83	0.75	0.61	0.46	1.00	0.78	0.64	0.49	1.00	0.80	0.66	0.51	1.00	0.82	0.68	0.53	1.00	1.00	0.73	0.59
	ΔT	23	21	18	14	23	21	18	14	23	22	18	14	23	21	18	14	23	21	18	14	24	22	19	15
	KW	1.73	1.73	1.72	1.74	1.92	1.92	1.92	1.93	2.13	2.13	2.13	2.14	2.37	2.36	2.36	2.37	2.62	2.62	2.62	2.63	2.93	2.92	2.92	2.94
	Amps	6.2	6.2	6.2	6.3	7.1	7.1	7.1	7.2	8.1	8.1	8.1	8.1	9.2	9.1	9.1	9.2	10.3	10.3	10.3	10.4	11.7	11.7	11.7	11.8
	HI PR	246	247	249	253	285	286	287	292	325	326	328	332	368	369	371	375	415	416	418	422	465	466	468	472
LO PR	124	126	129	134	132	133	137	142	138	140	143	148	144	145	149	154	149	151	154	159	156	158	161	166	
1125	MBh	30.0	30.4	31.2	32.6	29.7	30.1	31.0	32.3	28.9	29.3	30.2	31.5	27.6	28.0	28.9	30.2	26.0	26.4	27.3	28.6	24.6	25.0	25.9	27.2
	S/T	0.86	0.78	0.64	0.49	1.00	0.79	0.65	0.50	1.00	0.81	0.67	0.52	1.00	0.83	0.69	0.54	1.00	0.86	0.72	0.57	1.00	1.00	0.77	0.62
	ΔT	22	20	17	13	22	20	17	13	22	21	17	13	22	20	17	13	22	20	17	13	23	21	18	14
	KW	1.74	1.74	1.73	1.75	1.93	1.93	1.92	1.94	2.14	2.14	2.14	2.15	2.37	2.37	2.37	2.38	2.63	2.63	2.63	2.64	2.93	2.93	2.93	2.94
	Amps	6.3	6.3	6.3	6.3	7.2	7.1	7.1	7.2	8.1	8.1	8.1	8.2	9.2	9.2	9.2	9.2	10.4	10.4	10.4	10.4	11.8	11.8	11.7	11.8
	HI PR	248	249	251	255	287	288	289	294	327	328	330	334	370	371	373	377	417	418	420	424	467	468	470	474
LO PR	126	128	131	136	134	135	139	144	140	142	145	150	146	147	151	156	151	153	156	161	158	160	163	168	

IDB: Entering Indoor Dry Bulb Temperature
 High and low pressures are measured at the liquid and suction service valves.
 Shaded area reflects ACCA (TVA) conditions
 kW = Total system power
 Amps = outdoor unit amps (comp.-fan)

GSX140311K* + CA*F3137*6** + EEP (CONT.)

IDB		OUTDOOR AMBIENT TEMPERATURE												ENTERING INDOOR WET BULB TEMPERATURE											
		65				75				85				95				105				115			
		59	63	67	71	59	63	67	71	59	63	67	71	59	63	67	71	59	63	67	71	59	63	67	71
875	MBh	29.3	29.7	30.5	31.9	29.0	29.4	30.3	31.6	28.2	28.7	29.5	30.9	26.9	27.3	28.2	29.5	25.3	25.8	26.6	27.9	23.9	24.3	25.2	26.5
	S/T	1.00	0.81	0.67	0.5	1.00	0.82	0.68	0.53	1.00	0.85	0.70	0.6	1.00	0.87	0.73	0.58	1.00	1.00	0.75	0.6	1.00	1.00	0.80	0.65
	ΔT	28	27	23	19	28	27	23	19	29	27	23	20	28	27	23	19	28	26	23	19	29	27	24	20
	KW	1.72	1.72	1.72	1.7	1.91	1.91	1.91	1.92	2.12	2.12	2.12	2.1	2.36	2.35	2.35	2.37	2.61	2.61	2.61	2.6	2.92	2.92	2.91	2.93
	Amps	6.2	6.2	6.2	6.2	7.1	7.1	7.1	7.1	8.1	8.0	8.0	8.1	9.1	9.1	9.1	9.2	10.3	10.3	10.3	10.3	11.7	11.7	11.7	11.7
	HI PR	245	246	247	252	283	284	286	290	323	324	326	330	367	368	370	374	414	415	416	421	464	465	466	471
LO PR	123	125	128	133	131	132	135	140	137	139	142	147	143	144	147	153	148	150	153	158	155	156	160	165	
80	MBh	29.6	30.1	30.9	32.3	29.4	29.8	30.7	32.0	28.6	29.0	29.9	31.2	27.3	27.7	28.6	29.9	25.7	26.1	27.0	28.3	24.3	24.7	25.5	26.9
	S/T	1.00	0.88	0.73	0.6	1.00	0.88	0.74	0.59	1.00	0.91	0.77	0.6	1.00	1.00	0.79	0.64	1.00	1.00	0.81	0.7	1.00	1.00	0.86	0.72
	ΔT	27	25	22	18	27	25	22	18	28	26	22	19	27	25	22	18	27	25	22	18	28	26	23	19
	KW	1.73	1.73	1.72	1.7	1.92	1.92	1.92	1.93	2.13	2.13	2.13	2.1	2.37	2.36	2.36	2.38	2.62	2.62	2.62	2.6	2.93	2.93	2.92	2.94
	Amps	6.2	6.2	6.2	6.3	7.1	7.1	7.1	7.2	8.1	8.1	8.1	8.1	9.2	9.2	9.1	9.2	10.3	10.3	10.3	10.4	11.7	11.7	11.7	11.8
	HI PR	247	248	249	254	285	286	288	292	325	326	328	332	369	370	372	376	416	417	418	423	466	467	468	473
LO PR	125	126	130	135	132	134	137	142	139	140	144	149	144	146	149	154	150	151	155	160	157	158	161	167	
1125	MBh	30.1	30.5	31.4	32.7	29.8	30.3	31.1	32.5	29.1	29.5	30.4	31.7	27.8	28.2	29.1	30.4	26.2	26.6	27.5	28.8	24.7	25.1	26.0	27.3
	S/T	1.00	0.91	0.77	0.6	1.00	0.92	0.78	0.63	1.00	0.94	0.80	0.7	1.00	1.00	0.82	0.67	1.00	1.00	0.85	0.7	1.00	1.00	0.90	0.75
	ΔT	26	25	21	17	26	24	21	17	27	25	21	18	26	24	21	17	26	24	21	17	27	25	22	18
	KW	1.74	1.74	1.73	1.8	1.93	1.93	1.92	1.94	2.14	2.14	2.14	2.2	2.37	2.37	2.37	2.38	2.63	2.63	2.63	2.6	2.94	2.93	2.93	2.95
	Amps	6.3	6.3	6.3	6.3	7.2	7.2	7.1	7.2	8.1	8.1	8.1	8.2	9.2	9.2	9.2	9.2	10.4	10.4	10.4	10.4	11.8	11.8	11.7	11.8
	HI PR	249	250	251	256	287	288	290	294	327	328	330	334	371	372	374	378	418	419	420	425	468	469	470	475
LO PR	127	128	132	137	134	136	139	144	141	142	146	151	146	148	151	156	152	153	157	162	159	160	163	169	

IDB		OUTDOOR AMBIENT TEMPERATURE												ENTERING INDOOR WET BULB TEMPERATURE											
		65				75				85				95				105				115			
		59	63	67	71	59	63	67	71	59	63	67	71	59	63	67	71	59	63	67	71	59	63	67	71
875	MBh	29.8	30.2	31.0	32.4	29.5	29.9	30.8	32.1	28.7	29.1	30.0	31.3	27.4	27.8	28.7	30.0	25.8	26.2	27.1	28.4	24.4	24.8	25.7	27.0
	S/T	1.00	0.92	0.78	0.63	1.00	0.92	0.78	0.64	1.00	1.00	0.81	0.66	1.00	1.00	0.83	0.68	1.00	1.00	0.85	0.70	1.00	1.00	1.00	0.76
	ΔT	32	30	27	23	32	30	27	23	32	30	27	23	32	30	27	23	32	30	26	23	33	31	28	24
	KW	1.72	1.72	1.72	1.73	1.91	1.91	1.91	1.92	2.13	2.13	2.12	2.14	2.36	2.36	2.36	2.37	2.62	2.62	2.61	2.63	2.92	2.92	2.92	2.93
	Amps	6.2	6.2	6.2	6.3	7.1	7.1	7.1	7.1	8.1	8.1	8.0	8.1	9.1	9.1	9.1	9.2	10.3	10.3	10.3	10.4	11.7	11.7	11.7	11.7
	HI PR	246	247	248	253	284	285	287	291	325	326	327	332	368	369	371	375	415	416	417	422	465	466	467	472
LO PR	125	127	130	135	132	134	137	142	139	141	144	149	145	146	149	154	150	151	155	160	157	158	161	167	
1000	MBh	30.1	30.5	31.4	32.7	29.9	30.3	31.2	32.5	29.1	29.5	30.4	31.7	27.8	28.2	29.1	30.4	26.2	26.6	27.5	28.8	24.8	25.2	26.0	27.4
	S/T	1.00	0.98	0.84	0.69	1.00	1.00	0.85	0.70	1.00	1.00	0.87	0.72	1.00	1.00	0.89	0.74	1.00	1.00	0.92	0.77	1.00	1.00	1.00	0.82
	ΔT	31	29	26	22	31	29	26	22	31	29	26	22	31	29	26	22	31	29	25	22	32	30	26	23
	KW	1.73	1.73	1.73	1.74	1.92	1.92	1.92	1.93	2.14	2.14	2.13	2.15	2.37	2.37	2.36	2.38	2.63	2.63	2.62	2.64	2.93	2.93	2.93	2.94
	Amps	6.3	6.3	6.2	6.3	7.1	7.1	7.1	7.2	8.1	8.1	8.1	8.2	9.2	9.2	9.2	9.2	10.4	10.4	10.3	10.4	11.7	11.7	11.7	11.8
	HI PR	248	249	251	255	286	287	289	293	327	328	329	334	370	371	373	377	417	418	420	424	467	468	470	474
LO PR	127	128	131	137	134	136	139	144	141	142	145	151	146	148	151	156	152	153	156	162	159	160	163	168	
1125	MBh	30.6	31.0	31.9	33.2	30.3	30.7	31.6	32.9	29.6	30.0	30.9	32.2	28.3	28.7	29.5	30.9	26.7	27.1	28.0	29.3	25.2	25.6	26.5	27.8
	S/T	1.00	1.00	0.87	0.73	1.00	1.00	0.88	0.73	1.00	1.00	0.91	0.76	1.00	1.00	0.93	0.78	1.00	1.00	0.90	0.80	1.00	1.00	1.00	0.86
	ΔT	30	28	25	21	30	28	25	21	30	28	25	21	30	28	25	21	30	28	24	21	31	29	26	22
	KW	1.74	1.74	1.74	1.75	1.93	1.93	1.93	1.94	2.15	2.15	2.14	2.16	2.38	2.38	2.37	2.39	2.64	2.63	2.63	2.65	2.94	2.94	2.93	2.95
	Amps	6.3	6.3	6.3	6.3	7.2	7.2	7.2	7.2	8.2	8.1	8.1	8.2	9.2	9.2	9.2	9.3	10.4	10.4	10.4	10.4	11.8	11.8	11.8	11.8
	HI PR	250	251	253	257	288	289	291	295	329	330	331	336	372	373	375	379	419	420	422	426	469	470	472	476
LO PR	129	130	133	139	136	138	141	146	143	144	147	153	148	150	153	158	154	155	158	164	161	162	165	170	

IDB: Entering Indoor Dry Bulb Temperature
 High and low pressures are measured at the liquid and suction service valves.
 Shaded area reflects AHRI conditions
 kW = Total system power
 Amps = outdoor unit amps (comp.-fan)

GSX140361K* + CA*F3642*6** + EEP

IDB		OUTDOOR AMBIENT TEMPERATURE																																															
		65								75								85								95								105								115							
		AIRFLOW						ENTERING INDOOR WET BULB TEMPERATURE						ENTERING INDOOR WET BULB TEMPERATURE						ENTERING INDOOR WET BULB TEMPERATURE						ENTERING INDOOR WET BULB TEMPERATURE						ENTERING INDOOR WET BULB TEMPERATURE																	
59	63	67	71	59	63	67	71	59	63	67	71	59	63	67	71	59	63	67	71	59	63	67	71	59	63	67	71	59	63	67	71	59	63	67	71	59	63	67	71										
70	1050	MBh	34.8	35.3	36.3	-	34.5	35.0	36.0	-	33.6	34.1	35.1	-	32.0	32.5	33.5	-	30.1	30.6	31.6	-	28.4	28.8	29.9	-	30.1	30.6	31.6	-	28.4	28.8	29.9	-															
		S/T	0.59	0.52	0.38	-	0.60	0.52	0.39	-	0.62	0.55	0.42	-	0.64	0.57	0.43	-	1.00	0.59	0.46	-	1.00	0.64	0.51	-	1.00	0.59	0.46	-	1.00	0.64	0.51	-															
		ΔT	19	17	14	-	19	17	14	-	19	18	14	-	19	17	14	-	19	17	14	-	20	18	15	-	19	17	14	-	20	18	15	-															
	1200	KW	2.09	2.09	2.09	-	2.32	2.32	2.32	-	2.58	2.58	2.58	-	2.87	2.86	2.86	-	3.18	3.18	3.17	-	3.55	3.55	3.54	-	3.18	3.18	3.17	-	3.55	3.55	3.54	-															
		Amps	7.6	7.6	7.5	-	8.6	8.6	8.6	-	9.8	9.8	9.8	-	11.1	11.1	11.1	-	12.5	12.5	12.5	-	14.2	14.2	14.2	-	12.5	12.5	12.5	-	14.2	14.2	14.2	-															
		HI PR	254	255	257	-	294	295	297	-	336	337	339	-	381	382	384	-	430	431	433	-	482	483	485	-	430	431	433	-	482	483	485	-															
	1350	LO PR	121	123	126	-	129	130	133	-	135	137	140	-	141	142	145	-	146	147	151	-	153	154	157	-	146	147	151	-	153	154	157	-															
		MBh	35.3	35.7	36.8	-	34.9	35.4	36.5	-	34.0	34.5	35.6	-	32.5	33.0	34.0	-	30.6	31.0	32.1	-	28.8	29.3	30.3	-	30.6	31.0	32.1	-	28.8	29.3	30.3	-															
		S/T	0.65	0.58	0.44	-	0.66	0.58	0.45	-	0.68	0.61	0.47	-	0.70	0.63	0.49	-	1.00	0.65	0.51	-	1.00	0.70	0.56	-	1.00	0.65	0.51	-	1.00	0.70	0.56	-															
	1050	ΔT	18	16	13	-	18	16	13	-	18	17	13	-	18	16	13	-	18	16	13	-	19	17	14	-	18	16	13	-	19	17	14	-															
		KW	2.11	2.11	2.11	-	2.34	2.33	2.33	-	2.60	2.59	2.59	-	2.88	2.88	2.87	-	3.19	3.19	3.19	-	3.56	3.56	3.55	-	3.19	3.19	3.19	-	3.56	3.56	3.55	-															
		Amps	7.7	7.7	7.6	-	8.7	8.7	8.7	-	9.9	9.9	9.9	-	11.2	11.2	11.1	-	12.6	12.6	12.6	-	14.3	14.3	14.3	-	12.6	12.6	12.6	-	14.3	14.3	14.3	-															
1200	HI PR	256	257	259	-	296	297	299	-	338	339	341	-	384	385	386	-	432	433	435	-	484	485	487	-	432	433	435	-	484	485	487	-																
	LO PR	123	125	128	-	130	132	135	-	137	138	141	-	142	144	147	-	148	149	152	-	154	156	159	-	148	149	152	-	154	156	159	-																
	MBh	35.8	36.3	37.3	-	35.5	36.0	37.0	-	34.6	35.1	36.1	-	33.0	33.5	34.5	-	31.1	31.6	32.6	-	29.4	29.9	30.9	-	31.1	31.6	32.6	-	29.4	29.9	30.9	-																
1350	S/T	0.68	0.61	0.48	-	0.69	0.61	0.48	-	0.71	0.64	0.51	-	1.00	0.66	0.53	-	1.00	0.68	0.55	-	1.00	0.73	0.60	-	1.00	0.68	0.55	-	1.00	0.73	0.60	-																
	ΔT	17	15	12	-	17	15	12	-	17	16	12	-	17	15	12	-	17	15	12	-	18	16	13	-	17	15	12	-	18	16	13	-																
	KW	2.11	2.11	2.11	-	2.35	2.34	2.34	-	2.61	2.60	2.60	-	2.89	2.89	2.88	-	3.20	3.20	3.20	-	3.57	3.57	3.56	-	3.20	3.20	3.20	-	3.57	3.57	3.56	-																
1050	Amps	7.7	7.7	7.6	-	8.7	8.7	8.7	-	9.9	9.9	9.9	-	11.2	11.2	11.2	-	12.7	12.6	12.6	-	14.3	14.3	14.3	-	12.7	12.6	12.6	-	14.3	14.3	14.3	-																
	HI PR	258	259	261	-	298	300	301	-	340	342	343	-	386	387	389	-	434	435	437	-	486	488	489	-	434	435	437	-	486	488	489	-																
	LO PR	125	127	130	-	132	134	137	-	139	140	143	-	144	146	149	-	150	151	154	-	156	158	161	-	150	151	154	-	156	158	161	-																
75	1050	MBh	34.8	35.3	36.3	37.9	34.5	35.0	36.0	37.6	33.6	34.1	35.1	36.7	32.0	32.5	33.6	35.2	30.1	30.6	31.7	33.2	28.4	28.9	29.9	31.5	30.1	30.6	31.7	33.2	28.4	28.9	29.9	31.5															
		S/T	0.72	0.64	0.51	0.37	0.72	0.65	0.52	0.38	0.78	0.71	0.58	0.44	1.00	0.73	0.60	0.46	1.00	0.71	0.58	0.44	1.00	0.76	0.63	0.49	1.00	0.71	0.58	0.44	1.00	0.76	0.63	0.49															
		ΔT	23	21	18	15	23	21	18	15	23	22	18	15	23	22	17	14	15	23	21	18	14	24	22	19	15	23	21	18	14	24	22	19	15														
	1200	KW	2.09	2.09	2.08	2.10	2.32	2.32	2.32	2.33	2.58	2.58	2.58	2.59	2.86	2.86	2.86	2.88	3.18	3.18	3.17	3.19	3.55	3.54	3.54	3.56	3.18	3.18	3.17	3.19	3.55	3.54	3.54	3.56															
		Amps	7.6	7.6	7.5	8.0	8.6	8.6	8.6	8.7	9.8	9.8	9.8	10.0	11.1	11.1	11.1	11.2	12.5	12.5	12.5	13.0	14.2	14.2	14.3	14.3	12.5	12.5	12.5	13.0	14.2	14.2	14.2	14.3															
		HI PR	254	255	257	262	294	295	297	302	336	337	339	344	382	383	384	389	430	431	433	438	482	484	485	490	430	431	433	438	482	484	485	490															
	1350	LO PR	121	123	126	131	129	130	133	138	135	137	140	145	141	142	145	150	146	147	151	156	153	154	157	162	146	147	151	156	153	154	157	162															
		MBh	35.3	35.8	36.8	38.4	35.0	35.5	36.5	38.1	34.1	34.5	35.6	37.2	32.5	33.0	34.0	35.6	30.6	31.1	32.1	33.7	28.8	29.3	30.4	32.0	30.6	31.1	32.1	33.7	28.8	29.3	30.4	32.0															
		S/T	0.78	0.70	0.57	0.43	0.78	0.71	0.58	0.44	1.00	0.73	0.60	0.46	1.00	0.75	0.62	0.48	1.00	0.77	0.64	0.50	1.00	1.00	0.69	0.55	1.00	0.77	0.64	0.50	1.00	1.00	0.69	0.55															
	1050	ΔT	22	20	17	14	22	20	17	13	22	20	17	14	22	20	17	13	22	20	17	13	23	21	18	14	22	20	17	13	23	21	18	14															
		KW	2.10	2.10	2.10	2.11	2.33	2.33	2.33	2.35	2.59	2.59	2.59	2.61	2.88	2.87	2.87	2.89	3.19	3.19	3.18	3.20	3.56	3.56	3.55	3.57	3.19	3.19	3.18	3.20	3.56	3.56	3.55	3.57															
		Amps	7.6	7.6	7.6	8.0	8.7	8.7	8.7	9.0	9.9	9.9	9.9	10.0	11.2	11.2	11.1	11.0	12.6	12.6	12.6	13.0	14.3	14.3	14.3	14.0	12.6	12.6	12.6	13.0	14.3	14.3	14.3	14.0															
1200	HI PR	256	258	259	264	297	298	299	304	339	340	341	346	384	385	387	391	433	434	435	440	485	486	487	492	433	434	435	440	485	486	487	492																
	LO PR	123	125	128	133	130	132	135	140	137	138	141	147	142	144	147	152	148	149	152	157	154	156	159	164	148	149	152	157	154	156	159	164																
	MBh	35.8	36.3	37.4	38.9	35.5	36.0	37.0	38.6	34.6	35.1	36.1	37.7	33.0	33.5	34.6	36.2	31.1	31.6	32.7	34.2	29.4	29.9	30.9	32.5	31.1	31.6	32.7	34.2	29.4	29.9	30.9	32.5																
1350	S/T	0.81	0.73	0.60	0.46	0.82	0.74	0.61	0.47	1.00	0.77	0.63	0.49	1.00	0.78	0.65	0.51	1.00	0.81	0.67	0.53	1.00	1.00	0.72	0.58	1.00	0.81	0.67	0.53	1.00	1.00	0.72	0.58																
	ΔT	21	19	16	13	21	19	16	13	21	20	16	13	21	19	16	13	21	19	16	13	22	20	17	13	21	19	16	13	22	20	17	13																
	KW	2.11	2.11	2.11	2.12	2.34	2.34	2.34	2.36	2.60	2.60	2.60	2.62	2.89	2.88	2.88	2.90	3.20	3.20	3.19	3.21	3.57	3.57	3.56	3.58	3.20	3.20	3.19	3.21	3.57	3.57	3.56	3.58																
1050	Amps	7.7	7.7	7.6	8.0	8.7	8.7	8.7	9.0	9.9	9.9	9.9	10.0	11.2	11.2	11.1	11.0	12.6	12.6	12.6	13.0	14.3	14.3	14.3	14.0	12.6	12.6	12.6	13.0	14.3	14.3	14.3	14.0																
	HI PR	259	260	261	266	299	300	302	306	341	342	344	348	386	387	389	393	435	436	438	442	487	488	490	494	435	436	438	442	487	488	490	494																
	LO PR	125	127	130	135	132	134	137	142	139	140	143	149	144	146	149	154	150	151	154	159	156	158	161	166	150	151	154	159	156	158	161	166																

IDB: Entering Indoor Dry Bulb Temperature
 High and low pressures are measured at the liquid and suction service valves.
 Shaded area reflects ACCA (TVA) conditions
 kW = Total system power
 Amps = outdoor unit amps (comp.-fan)

GSX140361K* + CA*F3642*6** + EEP (CONT.)

IDB		OUTDOOR AMBIENT TEMPERATURE												ENTERING INDOOR WET BULB TEMPERATURE											
		65				75				85				95				105				115			
		59	63	67	71	59	63	67	71	59	63	67	71	59	63	67	71	59	63	67	71	59	63	67	71
80	MBh	35.0	35.5	36.5	38.1	34.7	35.2	36.2	37.8	33.8	34.3	35.3	36.9	32.2	32.7	33.7	35.3	30.3	30.8	31.8	33.4	28.6	29.0	30.1	31.7
	S/T	0.84	0.77	0.63	0.5	1.00	0.77	0.64	0.50	1.00	0.80	0.66	0.5	1.00	0.82	0.68	0.54	1.00	1.00	0.70	0.6	1.00	1.00	0.75	0.61
	ΔT	27	25	22	19	27	25	22	18	27	25	22	19	27	25	22	18	27	25	22	18	28	26	23	19
	KW	2.09	2.09	2.09	2.1	2.32	2.32	2.32	2.34	2.58	2.58	2.58	2.6	2.86	2.86	2.86	2.88	3.18	3.18	3.17	3.2	3.55	3.55	3.54	3.56
	Amps	7.6	7.6	7.5	8.0	8.6	8.6	8.6	9.0	9.8	9.8	9.8	10.0	11.1	11.1	11.1	11.0	12.5	12.5	12.5	13.0	14.2	14.2	14.2	14.0
	HI PR	255	256	258	262	295	296	298	302	337	338	340	344	382	383	385	389	431	432	434	438	483	484	486	490
	LO PR	122	123	126	132	129	131	134	139	136	137	140	145	141	143	146	151	146	148	151	156	153	155	158	163
	MBh	35.5	35.9	37.0	38.6	35.1	35.6	36.7	38.3	34.2	34.7	35.8	37.4	32.7	33.2	34.2	35.8	30.8	31.2	32.3	33.9	29.0	29.5	30.5	32.1
	S/T	1.00	0.82	0.69	0.6	1.00	0.83	0.70	0.56	1.00	0.85	0.72	0.6	1.00	0.87	0.74	0.60	1.00	1.00	0.76	0.6	1.00	1.00	0.81	0.67
	ΔT	26	24	21	17	26	24	21	17	26	24	21	18	26	24	21	17	26	24	21	17	27	25	22	18
KW	2.10	2.10	2.10	2.1	2.34	2.33	2.33	2.35	2.60	2.59	2.59	2.6	2.88	2.87	2.87	2.89	3.19	3.19	3.19	3.2	3.56	3.56	3.55	3.57	
Amps	7.6	7.6	7.6	8.0	8.7	8.7	8.7	9.0	9.9	9.9	9.9	10.0	11.2	11.2	11.1	11.0	12.6	12.6	12.6	13.0	14.3	14.3	14.3	14.0	
HI PR	257	258	260	264	297	298	300	304	339	340	342	346	384	385	387	392	433	434	436	440	485	486	488	492	
LO PR	124	125	128	133	131	132	136	141	137	139	142	147	143	144	147	153	148	150	153	158	155	156	160	165	
MBh	36.0	36.5	37.5	39.1	35.7	36.2	37.2	38.8	34.8	35.3	36.3	37.9	33.2	33.7	34.7	36.3	31.3	31.8	32.8	34.4	29.6	30.1	31.1	32.7	
S/T	1.00	0.86	0.72	0.6	1.00	0.86	0.73	0.59	1.00	0.89	0.76	0.6	1.00	1.00	0.77	0.63	1.00	1.00	0.80	0.7	1.00	1.00	0.85	0.71	
ΔT	25	23	20	17	25	23	20	17	25	24	20	17	25	23	20	16	25	23	20	16	26	24	21	17	
KW	2.11	2.11	2.11	2.1	2.35	2.34	2.34	2.36	2.61	2.60	2.60	2.6	2.89	2.89	2.88	2.90	3.20	3.20	3.20	3.2	3.57	3.57	3.56	4.00	
Amps	7.7	7.7	7.6	8.0	9.0	8.7	8.7	9.0	9.9	9.9	9.9	10.0	11.2	11.2	11.2	11.0	12.7	12.6	12.6	13.0	14.3	14.3	14.3	14.0	
HI PR	259	260	262	266	299	300	302	306	341	342	344	348	386	387	389	394	435	436	438	442	487	488	490	494	
LO PR	126	127	130	135	133	134	138	143	139	141	144	149	145	146	149	155	150	152	155	160	157	158	162	167	
85	MBh	35.6	36.1	37.1	38.7	35.3	35.8	36.8	38.4	34.4	34.9	35.9	37.5	32.8	33.3	34.3	35.9	30.9	31.4	32.4	34.0	29.1	29.6	30.7	32.3
	S/T	1.00	0.86	0.73	0.59	1.00	0.87	0.74	0.60	1.00	1.00	0.76	0.62	1.00	1.00	0.78	0.64	1.00	1.00	0.80	0.66	1.00	1.00	1.00	0.71
	ΔT	31	29	25	22	30	29	25	22	31	29	26	22	30	29	25	22	30	28	25	22	31	30	26	23
	KW	2.10	2.09	2.09	2.11	2.33	2.33	2.32	2.34	2.59	2.59	2.58	2.60	2.87	2.87	2.86	2.88	3.18	3.18	3.18	3.20	3.55	3.55	3.55	3.56
	Amps	7.6	7.6	7.6	8.0	8.7	8.6	8.6	9.0	9.8	9.8	9.8	10.0	11.1	11.1	11.1	11.0	12.6	12.6	12.5	13.0	14.3	14.2	14.2	14.0
	HI PR	256	257	259	263	296	297	299	303	338	339	341	345	383	384	386	391	432	433	435	439	484	485	487	491
	LO PR	124	125	128	133	131	133	136	141	137	139	142	147	143	144	148	153	148	150	153	158	155	157	160	165
	MBh	36.0	36.5	37.6	39.2	35.7	36.2	37.3	38.8	34.8	35.3	36.3	37.9	33.3	33.7	34.8	36.4	31.3	31.8	32.9	34.5	29.6	30.1	31.1	32.7
	S/T	1.00	0.92	0.79	0.65	1.00	0.93	0.80	0.66	1.00	1.00	0.82	0.68	1.00	1.00	0.84	0.70	1.00	1.00	0.86	0.72	1.00	1.00	1.00	0.77
	ΔT	29	28	24	21	29	28	24	21	30	28	25	21	29	28	24	21	29	27	24	21	30	28	25	22
KW	2.11	2.11	2.10	2.12	2.34	2.34	2.33	2.35	2.60	2.60	2.59	2.61	2.88	2.88	2.88	2.89	3.20	3.19	3.19	3.21	3.56	3.56	3.56	3.58	
Amps	7.6	7.6	7.6	8.0	8.7	8.7	8.7	9.0	9.9	9.9	9.9	10.0	11.2	11.2	11.2	11.0	12.6	12.6	12.6	13.0	14.3	14.3	14.3	14.0	
HI PR	258	259	261	265	298	299	301	306	340	341	343	348	385	387	388	393	434	435	437	442	486	487	489	494	
LO PR	125	127	130	135	133	134	137	143	139	141	144	149	145	146	149	154	150	152	155	160	157	158	161	167	
MBh	36.6	37.1	38.1	39.7	36.3	36.8	37.8	39.4	35.4	35.9	36.9	38.5	33.8	34.3	35.3	36.9	31.9	32.4	33.4	35.0	30.1	30.6	31.7	33.3	
S/T	1.00	0.96	0.82	0.68	1.00	1.00	0.83	0.69	1.00	1.00	0.85	0.71	1.00	1.00	0.87	0.73	1.00	1.00	0.89	0.76	1.00	1.00	1.00	0.81	
ΔT	29	27	23	20	29	27	23	20	29	27	24	20	28	27	23	20	28	26	23	20	29	28	24	21	
KW	2.12	2.12	2.11	2.13	2.35	2.35	2.34	2.36	2.61	2.61	2.60	2.62	2.89	2.89	2.89	2.90	3.21	3.20	3.20	3.22	3.57	3.57	3.57	3.59	
Amps	7.7	7.7	7.7	8.0	8.8	8.7	8.7	9.0	9.9	9.9	9.9	10.0	11.2	11.2	11.2	11.0	12.7	12.7	12.6	13.0	14.4	14.4	14.3	14.0	
HI PR	260	261	263	268	300	301	303	308	342	343	345	350	388	389	390	395	436	437	439	444	488	489	491	496	
LO PR	127	129	132	137	135	136	139	145	141	143	146	151	147	148	151	156	152	154	157	162	159	160	163	169	

IDB: Entering Indoor Dry Bulb Temperature
 High and low pressures are measured at the liquid and suction service valves.
 Shaded area reflects AHRI conditions
 kW = Total system power
 Amps = outdoor unit amps (comp.+fan)

GSX140371K* + CA*F3137*6** + EEP

IDB		OUTDOOR AMBIENT TEMPERATURE												ENTERING INDOOR WET BULB TEMPERATURE												ENTERING INDOOR DRY BULB TEMPERATURE											
		65				75				85				95				105				115															
		59	63	67	71	59	63	67	71	59	63	67	71	59	63	67	71	59	63	67	71	59	63	67	71	59	63	67	71								
70	1100	MBh	35.0	35.5	36.6	-	34.7	35.2	36.3	-	33.8	34.3	35.4	-	32.3	32.8	33.8	-	30.4	30.9	31.9	-	28.6	29.1	30.2	-	28.6	29.1	30.2	-							
		S/T	0.66	0.59	0.45	-	0.67	0.59	0.46	-	0.70	0.62	0.48	-	0.71	0.64	0.50	-	1.00	0.66	0.53	-	1.00	0.71	0.58	-	1.00	0.71	0.58	-							
		ΔT	20	18	14	-	20	18	14	-	20	18	14	-	19	18	14	-	19	17	14	-	20	19	15	-	20	19	15	-							
		Amps	2.03	2.03	2.02	-	2.26	2.26	2.26	-	2.53	2.53	2.52	-	2.81	2.81	2.81	-	3.13	3.13	3.13	-	3.51	3.50	3.50	-	3.51	3.50	3.50	-							
	1200	MBh	35.4	35.9	37.0	-	35.1	35.6	36.6	-	34.2	34.7	35.7	-	32.7	33.2	34.2	-	30.8	31.3	32.3	-	29.0	29.5	30.6	-	29.0	29.5	30.6	-							
		S/T	0.69	0.62	0.48	-	0.70	0.62	0.49	-	0.72	0.65	0.51	-	0.74	0.67	0.53	-	1.00	0.69	0.55	-	1.00	0.74	0.60	-	1.00	0.74	0.60	-							
		ΔT	19	17	13	-	19	17	13	-	19	17	14	-	19	17	13	-	19	17	13	-	20	18	14	-	20	18	14	-							
		Amps	2.04	2.03	2.03	-	2.27	2.27	2.27	-	2.54	2.53	2.53	-	2.82	2.82	2.82	-	3.14	3.14	3.13	-	3.51	3.51	3.51	-	3.51	3.51	3.51	-							
	1350	MBh	36.1	36.6	37.6	-	35.8	36.3	37.3	-	34.9	35.4	36.4	-	33.4	33.8	34.9	-	31.5	31.9	33.0	-	29.7	30.2	31.2	-	29.7	30.2	31.2	-							
		S/T	0.71	0.63	0.50	-	0.71	0.64	0.50	-	0.74	0.66	0.53	-	1.00	0.68	0.55	-	1.00	0.71	0.57	-	1.00	0.76	0.62	-	1.00	0.76	0.62	-							
		ΔT	18	16	12	-	18	16	12	-	18	16	13	-	18	16	12	-	18	16	12	-	19	17	13	-	19	17	13	-							
		Amps	2.05	2.04	2.04	-	2.28	2.28	2.28	-	2.55	2.54	2.54	-	2.83	2.83	2.83	-	3.15	3.15	3.14	-	3.52	3.52	3.52	-	3.52	3.52	3.52	-							
75	1100	MBh	35.1	35.6	36.6	38.2	34.8	35.2	36.3	37.9	33.9	34.3	35.4	37.0	32.3	32.8	33.8	35.4	30.4	30.9	31.9	33.5	28.7	29.2	30.2	31.8											
		S/T	0.79	0.72	0.58	0.44	0.80	0.72	0.59	0.45	1.00	0.75	0.61	0.47	1.00	0.77	0.63	0.49	1.00	0.79	0.65	0.51	1.00	0.84	0.71	0.56											
		ΔT	24	22	18	15	24	22	18	15	24	22	18	15	24	22	18	14	23	22	18	14	25	23	19	15											
		Amps	2.03	2.02	2.02	2.04	2.26	2.26	2.26	2.28	2.53	2.52	2.52	2.54	2.81	2.81	2.81	2.82	3.13	3.13	3.12	3.14	3.50	3.50	3.50	3.52											
	1200	MBh	35.5	35.9	37.0	38.6	35.1	35.6	36.7	38.2	34.2	34.7	35.8	37.3	32.7	33.2	34.2	35.8	30.8	31.3	32.3	33.9	29.1	29.5	30.6	32.2											
		S/T	0.82	0.74	0.61	0.47	0.83	0.75	0.61	0.47	1.00	0.77	0.64	0.50	1.00	0.79	0.66	0.52	1.00	0.82	0.68	0.54	1.00	1.00	0.73	0.59											
		ΔT	23	21	18	14	23	21	17	14	23	21	18	14	23	21	17	14	23	21	17	14	24	22	18	15											
		Amps	2.03	2.03	2.03	2.05	2.27	2.27	2.26	2.28	2.53	2.53	2.53	2.55	2.82	2.82	2.81	2.83	3.14	3.14	3.13	3.15	3.51	3.51	3.51	3.52											
	1350	MBh	36.1	36.6	37.7	39.2	35.8	36.3	37.4	38.9	34.9	35.4	36.4	38.0	33.4	33.9	34.9	36.5	31.5	32.0	33.0	34.6	29.7	30.2	31.3	32.8											
		S/T	0.84	0.76	0.63	0.48	0.84	0.77	0.63	0.49	1.00	0.79	0.66	0.51	1.00	0.81	0.68	0.53	1.00	0.83	0.70	0.56	1.00	1.00	0.75	0.61											
		ΔT	22	20	17	13	22	20	17	13	22	20	17	13	22	20	17	13	22	20	16	13	23	21	17	14											
		Amps	2.04	2.04	2.04	2.06	2.28	2.28	2.27	2.29	2.54	2.54	2.54	2.56	2.83	2.83	2.82	2.84	3.15	3.15	3.14	3.16	3.52	3.52	3.52	3.53											

IDB: Entering Indoor Dry Bulb Temperature
 High and low pressures are measured at the liquid and suction service valves.
 Shaded area reflects ACCA (TVA) conditions
 kW = Total system power
 Amps = outdoor unit amps (comp.-fan)

GSX140371K* + CA*F3137*6** + EEP (CONT.)

IDB		OUTDOOR AMBIENT TEMPERATURE												ENTERING INDOOR WET BULB TEMPERATURE													
		65				75				85				95				105				115					
		59	63	67	71	59	63	67	71	59	63	67	71	59	63	67	71	59	63	67	71	59	63	67	71		
80	1100	MBh	35.2	35.7	36.8	38.3	34.9	35.4	36.5	38.0	34.0	34.5	35.6	37.1	32.5	33.0	34.0	35.6	30.6	31.1	32.1	33.7	28.8	29.3	30.4	31.9	
		S/T	0.92	0.84	0.71	0.6	1.00	0.85	0.71	0.57	1.00	0.87	0.74	0.6	1.00	0.89	0.76	0.61	1.00	1.00	1.00	0.78	0.6	1.00	1.00	0.83	0.69
		ΔT	28	26	23	19	28	26	22	19	28	26	23	19	28	26	22	19	28	28	26	22	18	29	27	23	20
	1200	KW	2.03	2.03	2.02	2.0	2.26	2.26	2.26	2.28	2.53	2.53	2.52	2.5	2.81	2.81	2.81	2.83	3.13	3.13	3.13	3.13	3.1	3.51	3.50	3.50	3.52
		Amps	7.4	7.4	7.4	7.5	8.5	8.5	8.5	8.6	9.7	9.7	9.7	9.8	11.0	11.0	11.0	11.1	12.5	12.5	12.5	12.6	14.2	14.2	14.2	14.3	
		HI PR	256	257	259	263	296	297	298	303	337	339	340	345	382	384	385	390	431	432	434	438	483	484	486	490	
	1350	LO PR	122	124	127	132	130	131	134	139	136	137	140	146	141	143	146	151	147	148	151	156	153	155	158	163	
		MBh	35.6	36.1	37.2	38.7	35.3	35.8	36.8	38.4	34.4	34.9	35.9	37.5	32.9	33.4	34.4	36.0	31.0	31.5	32.5	34.1	29.2	29.7	30.8	32.3	
		S/T	1.00	0.87	0.73	0.6	1.00	0.87	0.74	0.60	1.00	0.90	0.76	0.6	1.00	0.92	0.78	0.64	1.00	1.00	0.81	0.7	1.00	1.00	0.86	0.72	
	85	1100	ΔT	27	25	22	18	27	25	22	18	27	26	22	18	27	25	22	18	27	25	21	18	28	26	23	19
			KW	2.04	2.03	2.03	2.1	2.27	2.27	2.27	2.28	2.54	2.53	2.53	2.6	2.82	2.82	2.81	2.83	3.14	3.14	3.13	3.2	3.51	3.51	3.51	3.53
			Amps	7.5	7.5	7.5	7.5	8.6	8.6	8.5	8.6	9.8	9.8	9.7	9.8	11.1	11.1	11.1	11.1	12.5	12.5	12.5	12.6	14.2	14.2	14.2	14.3
1200		HI PR	257	258	260	265	297	298	300	304	339	340	342	346	384	385	387	391	432	434	435	440	484	485	487	492	
		LO PR	124	125	128	133	131	132	135	141	137	139	142	147	143	144	147	152	148	150	153	158	155	156	159	164	
		MBh	36.3	36.8	37.8	39.4	36.0	36.5	37.5	39.1	35.1	35.6	36.6	38.2	33.6	34.0	35.1	36.7	31.7	32.1	33.2	34.8	29.9	30.4	31.4	33.0	
1350		S/T	1.00	0.89	0.75	0.6	1.00	0.89	0.76	0.61	1.00	0.92	0.78	0.6	1.00	1.00	0.80	0.66	1.00	1.00	0.82	0.7	1.00	1.00	0.88	0.73	
		ΔT	26	24	21	17	26	24	21	17	27	25	21	17	26	24	21	17	26	24	20	17	27	25	22	18	
		KW	2.05	2.04	2.04	2.1	2.28	2.28	2.28	2.29	2.55	2.54	2.54	2.6	2.83	2.83	2.83	2.84	3.15	3.15	3.14	3.2	3.52	3.52	3.52	3.54	
85		1100	Amps	7.5	7.5	7.5	7.6	8.6	8.6	8.6	8.7	9.8	9.8	9.9	11.1	11.1	11.1	11.2	12.6	12.6	12.6	12.6	14.3	14.3	14.3	14.3	
			HI PR	260	261	262	267	299	301	302	307	341	342	344	349	386	387	389	394	435	436	438	442	487	488	489	494
			LO PR	126	127	131	136	133	135	138	143	140	141	144	149	145	147	150	155	150	152	155	160	157	159	162	167
	1200	MBh	35.8	36.3	37.3	38.9	35.5	36.0	37.0	38.6	34.6	35.1	36.1	37.7	33.1	33.5	34.6	36.2	31.2	31.7	32.7	34.3	29.4	29.9	30.9	32.5	
		S/T	1.00	0.94	0.81	0.67	1.00	0.95	0.81	0.67	1.00	1.00	0.84	0.70	1.00	1.00	0.89	0.74	1.00	1.00	0.88	0.74	1.00	1.00	1.00	0.79	
		ΔT	32	30	26	23	32	30	26	23	32	30	26	23	32	30	26	22	31	30	26	22	33	31	27	23	
	1350	KW	2.03	2.03	2.03	2.04	2.27	2.27	2.26	2.28	2.53	2.53	2.53	2.54	2.82	2.82	2.81	2.83	3.14	3.13	3.13	3.15	3.51	3.51	3.50	3.52	
		Amps	7.5	7.5	7.4	7.5	8.5	8.5	8.5	8.6	9.8	9.7	9.7	9.8	11.1	11.1	11.0	11.1	12.5	12.5	12.5	12.6	14.2	14.2	14.2	14.3	
		HI PR	257	258	260	264	297	298	300	304	339	340	341	346	384	385	386	391	432	433	435	439	484	485	487	491	
	85	1200	LO PR	124	126	129	134	131	133	136	141	138	139	142	147	143	145	148	153	148	150	153	158	155	157	160	165
			MBh	36.2	36.7	37.7	39.3	35.9	36.4	37.4	39.0	35.0	35.5	36.5	38.1	33.4	33.9	35.0	36.5	31.5	32.0	33.1	34.6	29.8	30.3	31.3	32.9
			S/T	1.00	0.97	0.83	0.69	1.00	0.98	0.84	0.70	1.00	1.00	0.87	0.72	1.00	1.00	0.89	0.74	1.00	1.00	0.91	0.76	1.00	1.00	1.00	0.82
1350		ΔT	31	29	26	22	31	29	25	22	31	29	26	22	31	29	25	22	31	29	25	22	32	30	26	23	
		KW	2.04	2.04	2.03	2.05	2.28	2.27	2.27	2.29	2.54	2.54	2.53	2.55	2.83	2.82	2.82	2.84	3.14	3.14	3.14	3.16	3.52	3.52	3.51	3.53	
		Amps	7.5	7.5	7.5	7.6	8.6	8.6	8.6	8.6	9.8	9.8	9.8	9.8	11.1	11.1	11.1	11.2	12.6	12.5	12.5	12.6	14.3	14.3	14.3	14.3	
1350		HI PR	258	260	261	266	298	299	301	306	340	341	343	347	385	386	388	392	434	435	437	441	485	487	488	493	
		LO PR	125	127	130	135	133	134	137	142	139	141	144	149	145	146	149	154	150	151	154	159	156	158	161	166	
		MBh	36.9	37.4	38.4	40.0	36.6	37.1	38.1	39.7	35.7	36.2	37.2	38.8	34.1	34.6	35.7	37.2	32.2	32.7	33.8	35.3	30.5	31.0	32.0	33.6	
1350		S/T	1.00	0.99	0.85	0.71	1.00	1.00	0.86	0.72	1.00	1.00	0.88	0.74	1.00	1.00	0.90	0.76	1.00	1.00	0.92	0.78	1.00	1.00	1.00	0.83	
		ΔT	30	28	25	21	30	28	25	21	30	28	25	21	30	28	25	21	30	28	24	21	31	29	25	22	
		KW	2.05	2.05	2.04	2.06	2.29	2.28	2.28	2.30	2.55	2.55	2.54	2.56	2.84	2.83	2.83	2.85	3.15	3.15	3.15	3.17	3.53	3.53	3.52	3.54	
1350	Amps	7.5	7.5	7.5	7.6	8.6	8.6	8.6	8.7	9.8	9.8	9.8	9.9	11.1	11.1	11.1	11.2	12.6	12.6	12.6	12.7	14.3	14.3	14.3	14.4		
	HI PR	261	262	264	268	301	302	304	308	342	344	345	350	387	389	390	395	436	437	439	443	488	489	491	495		
	LO PR	128	129	132	137	135	137	140	145	141	143	146	151	147	148	151	157	152	154	157	162	159	160	163	168		

IDB: Entering Indoor Dry Bulb Temperature
 High and low pressures are measured at the liquid and suction service valves.
 Shaded area reflects AHRI conditions
 kW = Total system power
 Amps = outdoor unit amps (comp.+fan)

GSX140421K* + CA*F4961*6** + EEP

IDB		OUTDOOR AMBIENT TEMPERATURE												ENTERING INDOOR WET BULB TEMPERATURE											
		65				75				85				95				105				115			
		59	63	67	71	59	63	67	71	59	63	67	71	59	63	67	71	59	63	67	71	59	63	67	71
70	MBh	39.7	40.2	41.4	-	39.3	39.9	41.1	-	38.3	38.8	40.0	-	36.5	37.1	38.2	-	34.3	34.9	36.1	-	32.3	32.9	34.1	-
	S/T	0.63	0.55	0.41	-	0.64	0.56	0.42	-	0.66	0.58	0.44	-	1.00	0.60	0.46	-	1.00	0.63	0.49	-	1.00	0.68	0.54	-
	ΔT	20	18	15	-	20	18	15	-	20	18	15	-	20	18	15	-	20	18	14	-	21	19	15	-
	KW	2.32	2.32	2.31	-	2.59	2.59	2.58	-	2.89	2.89	2.88	-	3.21	3.21	3.21	-	3.58	3.57	3.57	-	4.00	4.00	4.00	-
	Amps	8.3	8.3	8.3	-	9.5	9.5	9.5	-	10.9	10.9	10.9	-	12.4	12.4	12.3	-	14.0	14.0	14.0	-	16.0	16.0	16.0	-
	HI PR	264	266	267	-	306	307	309	-	350	351	353	-	397	398	400	-	448	449	451	-	502	503	505	-
	LO PR	126	128	131	-	134	135	139	-	140	142	145	-	146	148	151	-	152	153	157	-	159	160	163	-
	MBh	40.2	40.8	41.9	-	39.8	40.4	41.6	-	38.8	39.4	40.6	-	37.0	37.6	38.8	-	34.8	35.4	36.6	-	32.9	33.4	34.6	-
	S/T	0.69	0.61	0.47	-	0.70	0.62	0.48	-	0.73	0.65	0.51	-	1.00	0.67	0.53	-	1.00	0.69	0.55	-	1.00	0.74	0.60	-
	ΔT	19	17	13	-	19	17	13	-	19	17	14	-	19	17	13	-	18	17	13	-	20	18	14	-
KW	2.34	2.33	2.33	-	2.60	2.60	2.60	-	2.90	2.90	2.90	-	3.23	3.23	3.22	-	3.59	3.59	3.58	-	4.02	4.01	4.01	-	
Amps	8.4	8.3	8.3	-	9.6	9.6	9.6	-	11.0	10.9	10.9	-	12.4	12.4	12.4	-	14.1	14.1	14.1	-	16.0	16.0	16.0	-	
HI PR	267	268	270	-	308	309	311	-	352	353	355	-	399	400	402	-	450	451	453	-	504	505	507	-	
LO PR	128	130	133	-	136	137	140	-	142	144	147	-	148	150	153	-	154	155	158	-	161	162	165	-	
MBh	40.8	41.4	42.6	-	40.5	41.0	42.2	-	39.4	40.0	41.2	-	37.7	38.2	39.4	-	35.5	36.0	37.2	-	33.5	34.0	35.2	-	
S/T	0.73	0.65	0.51	-	0.74	0.66	0.52	-	1.00	0.68	0.54	-	1.00	0.70	0.56	-	1.00	0.73	0.58	-	1.00	1.00	0.64	-	
ΔT	18	16	13	-	18	16	12	-	18	16	13	-	18	16	12	-	17	16	12	-	19	17	13	-	
KW	2.35	2.34	2.34	-	2.62	2.61	2.61	-	2.92	2.91	2.91	-	3.24	3.24	3.23	-	3.60	3.60	3.60	-	4.03	4.03	4.02	-	
Amps	8.4	8.4	8.4	-	9.6	9.6	9.6	-	11.0	11.0	11.0	-	12.5	12.5	12.5	-	14.2	14.1	14.1	-	16.1	16.1	16.1	-	
HI PR	269	270	272	-	311	312	314	-	354	355	357	-	401	402	404	-	452	453	455	-	506	507	509	-	
LO PR	130	132	135	-	138	139	142	-	144	146	149	-	150	152	155	-	156	157	160	-	163	164	167	-	
75	MBh	39.7	40.3	41.4	43.3	39.3	39.9	41.1	42.9	38.3	38.9	40.1	41.9	36.5	37.1	38.3	40.1	34.3	34.9	36.1	37.9	32.4	32.9	34.1	35.9
	S/T	0.77	0.69	0.55	0.40	1.00	0.69	0.55	0.40	1.00	0.72	0.58	0.43	1.00	0.74	0.60	0.45	1.00	0.76	0.62	0.47	1.00	1.00	0.67	0.53
	ΔT	24	22	19	15	24	22	19	15	24	22	19	15	24	22	19	15	24	22	18	15	25	23	19	16
	KW	2.32	2.32	2.31	2.33	2.59	2.59	2.58	2.60	2.89	2.89	2.88	2.90	3.21	3.21	3.21	3.23	3.58	3.57	3.57	3.59	4.00	4.00	3.99	4.01
	Amps	8.3	8.3	8.3	8.0	9.5	9.5	9.5	9.6	10.9	10.9	10.9	11.0	12.4	12.4	12.3	12.4	14.0	14.0	14.0	14.0	16.0	16.0	15.9	16.0
	HI PR	265	266	268	272	306	307	309	314	350	351	353	358	397	398	400	405	448	449	451	455	502	503	505	510
	LO PR	126	128	131	136	134	135	139	144	141	142	145	151	146	148	151	156	152	153	157	162	159	160	164	169
	MBh	40.2	40.8	42.0	43.8	39.9	40.4	41.6	43.4	38.8	39.4	40.6	42.4	37.0	37.6	38.8	40.6	34.9	35.4	36.6	38.4	32.9	33.4	34.6	36.4
	S/T	0.83	0.75	0.61	0.46	1.00	0.76	0.61	0.47	1.00	0.78	0.64	0.49	1.00	0.80	0.66	0.51	1.00	1.00	0.68	0.53	1.00	1.00	0.74	0.59
	ΔT	23	21	17	14	23	21	17	14	23	21	18	14	23	21	17	14	22	21	17	14	24	22	18	15
KW	2.33	2.33	2.33	2.35	2.60	2.60	2.60	2.62	2.90	2.90	2.90	2.92	3.23	3.23	3.22	3.24	3.59	3.59	3.58	3.60	4.01	4.01	4.01	4.03	
Amps	8.3	8.3	8.3	8.0	9.6	9.6	9.6	10.0	10.9	10.9	10.9	11.0	12.4	12.4	12.4	12.0	14.1	14.1	14.1	14.0	16.0	16.0	16.0	16.1	
HI PR	267	268	270	274	309	310	312	316	352	353	355	360	399	400	402	407	450	451	453	458	504	505	507	512	
LO PR	128	130	133	138	136	137	140	146	142	144	147	153	148	150	153	158	154	155	158	164	161	162	165	171	
MBh	40.8	41.4	42.6	44.4	40.5	41.1	42.2	44.0	39.5	40.0	41.2	43.0	37.7	38.2	39.4	41.2	35.5	36.1	37.2	39.1	33.5	34.1	35.3	37.1	
S/T	0.86	0.78	0.64	0.49	1.00	0.79	0.65	0.50	1.00	0.82	0.68	0.53	1.00	0.84	0.70	0.55	1.00	1.00	0.72	0.57	1.00	1.00	0.77	0.62	
ΔT	22	20	17	13	22	20	17	13	22	20	17	13	22	20	16	13	21	20	16	13	23	21	17	14	
KW	2.35	2.34	2.34	2.36	2.61	2.61	2.61	2.63	2.91	2.91	2.91	2.93	3.24	3.24	3.23	3.25	3.60	3.60	3.59	3.61	4.03	4.02	4.02	4.04	
Amps	8.4	8.4	8.4	8.0	9.6	9.6	9.6	10.0	11.0	11.0	11.0	11.0	12.5	12.5	12.5	13.0	14.1	14.1	14.1	14.0	16.1	16.1	16.1	16.2	
HI PR	269	270	272	277	311	312	314	318	354	356	357	362	402	403	405	409	452	453	455	460	506	508	509	514	
LO PR	130	132	135	140	138	139	142	148	144	146	149	155	150	152	155	160	156	157	160	166	163	164	167	173	

IDB: Entering Indoor Dry Bulb Temperature
 High and low pressures are measured at the liquid and suction service valves.
 Shaded area reflects ACCA (TVA) conditions
 kW = Total system power
 Amps = outdoor unit amps (comp.-fan)

GSX140421K* + CA*F4961*6** + EEP (CONT.)

IDB		OUTDOOR AMBIENT TEMPERATURE												ENTERING INDOOR WET BULB TEMPERATURE											
		65				75				85				95				105				115			
		59	63	67	71	59	63	67	71	59	63	67	71	59	63	67	71	59	63	67	71	59	63	67	71
80	MBh	39.9	40.5	41.7	43.5	39.6	40.1	41.3	43.1	38.5	39.1	40.3	42.1	36.7	37.3	38.5	40.3	34.6	35.1	36.3	38.1	32.6	33.1	34.3	36.1
	S/T	1.00	0.82	0.68	0.5	1.00	0.82	0.68	0.53	1.00	0.85	0.71	0.6	1.00	1.00	0.73	0.58	1.00	1.00	0.75	0.6	1.00	1.00	0.81	0.66
	ΔT	28	26	23	19	28	26	23	19	28	26	23	19	28	26	23	19	28	26	22	19	29	27	23	20
	KW	2.32	2.32	2.31	2.3	2.59	2.59	2.58	2.60	2.89	2.89	2.88	2.9	3.21	3.21	3.21	3.23	3.58	3.57	3.57	3.6	4.00	4.00	4.00	4.02
	Amps	8.3	8.3	8.3	8.0	9.5	9.5	9.5	10.0	10.9	10.9	10.9	11.0	12.4	12.4	12.3	12.0	14.0	14.0	14.0	14.0	16.0	16.0	16.0	16.0
	HI PR	265	266	268	273	307	308	310	314	351	352	354	358	398	399	401	405	448	449	451	456	502	504	505	510
	LO PR	127	128	131	137	134	136	139	144	141	143	146	151	147	148	152	157	152	154	157	162	159	161	164	169
	MBh	40.4	41.0	42.2	44.0	40.1	40.6	41.8	43.6	39.0	39.6	40.8	42.6	37.3	37.8	39.0	40.8	35.1	35.6	36.8	38.6	33.1	33.6	34.8	36.6
	S/T	1.00	0.88	0.74	0.6	1.00	0.89	0.74	0.60	1.00	0.91	0.77	0.6	1.00	1.00	0.79	0.64	1.00	1.00	0.81	0.7	1.00	1.00	0.87	0.72
	ΔT	27	25	22	18	27	25	21	18	27	25	22	18	27	25	21	18	26	25	21	18	28	26	22	19
KW	2.33	2.33	2.33	2.4	2.60	2.60	2.60	2.62	2.90	2.90	2.90	2.9	3.23	3.23	3.22	3.24	3.59	3.59	3.58	3.6	4.02	4.01	4.01	4.03	
Amps	8.4	8.3	8.3	8.0	9.6	9.6	9.6	10.0	11.0	11.0	10.9	11.0	12.4	12.4	12.4	12.0	14.1	14.1	14.1	14.0	16.0	16.0	16.0	16.1	
HI PR	267	268	270	275	309	310	312	317	353	354	356	360	400	401	403	407	451	452	454	458	505	506	508	512	
LO PR	129	130	133	139	136	138	141	146	143	144	148	153	149	150	153	159	154	156	159	164	161	163	166	171	
MBh	41.1	41.6	42.8	44.6	40.7	41.3	42.4	44.3	39.7	40.2	41.4	43.2	37.9	38.4	39.6	41.4	35.7	36.3	37.4	39.3	33.7	34.3	35.5	37.3	
S/T	1.00	0.91	0.77	0.6	1.00	0.92	0.78	0.63	1.00	1.00	0.81	0.7	1.00	1.00	0.83	0.68	1.00	1.00	0.85	0.7	1.00	1.00	1.00	0.75	
ΔT	26	24	21	17	26	24	21	17	26	24	21	17	26	24	21	17	26	24	20	17	27	25	21	18	
KW	2.35	2.34	2.34	2.4	2.62	2.61	2.61	2.63	2.92	2.91	2.91	2.9	3.24	3.24	3.23	3.25	3.60	3.60	3.60	3.6	4.03	4.03	4.02	4.00	
Amps	8.4	8.4	8.4	8.0	9.6	9.6	9.6	10.0	11.0	11.0	11.0	11.0	12.5	12.5	12.5	13.0	14.2	14.1	14.1	14.0	16.1	16.1	16.1	16.2	
HI PR	270	271	273	277	311	312	314	319	355	356	358	363	402	403	405	410	453	454	456	460	507	508	510	514	
LO PR	131	132	135	141	138	140	143	148	145	147	150	155	151	152	155	161	156	158	161	166	163	165	168	173	

IDB		OUTDOOR AMBIENT TEMPERATURE												ENTERING INDOOR WET BULB TEMPERATURE											
		65				75				85				95				105				115			
		59	63	67	71	59	63	67	71	59	63	67	71	59	63	67	71	59	63	67	71	59	63	67	71
85	MBh	40.6	41.1	42.3	44.1	40.2	40.8	42.0	43.8	39.2	39.7	40.9	42.7	37.4	38.0	39.1	41.0	35.2	35.8	37.0	38.8	33.2	33.8	35.0	36.8
	S/T	1.00	0.92	0.78	0.63	1.00	1.00	0.79	0.64	1.00	1.00	0.81	0.67	1.00	1.00	0.83	0.69	1.00	1.00	1.00	0.71	1.00	1.00	1.00	0.76
	ΔT	31	30	26	23	31	30	26	23	32	30	26	23	31	30	26	23	31	29	26	22	32	30	27	24
	KW	2.33	2.32	2.32	2.34	2.59	2.59	2.59	2.61	2.89	2.89	2.89	2.91	3.22	3.22	3.21	3.23	3.58	3.58	3.58	3.60	4.01	4.01	4.00	4.02
	Amps	8.3	8.3	8.3	8.0	9.5	9.5	9.5	10.0	10.9	10.9	10.9	11.0	12.4	12.4	12.4	12.0	14.1	14.0	14.0	14.0	16.0	16.0	16.0	16.1
	HI PR	266	267	269	274	308	309	311	316	352	353	355	359	399	400	402	406	450	451	453	457	504	505	507	511
	LO PR	129	130	133	139	136	138	141	146	143	145	148	153	149	150	153	159	154	156	159	164	161	163	166	171
	MBh	41.1	41.7	42.8	44.7	40.7	41.3	42.5	44.3	39.7	40.3	41.5	43.3	37.9	38.5	39.7	41.5	35.7	36.3	37.5	39.3	33.8	34.3	35.5	37.3
	S/T	1.00	0.99	0.84	0.69	1.00	1.00	0.85	0.70	1.00	1.00	0.88	0.73	1.00	1.00	0.90	0.75	1.00	1.00	1.00	0.77	1.00	1.00	1.00	0.82
	ΔT	30	29	25	22	30	28	25	22	31	29	25	22	30	28	25	22	30	28	25	21	31	29	26	22
KW	2.34	2.34	2.33	2.35	2.61	2.61	2.60	2.62	2.91	2.91	2.90	2.92	3.23	3.23	3.23	3.25	3.60	3.59	3.59	3.61	4.02	4.02	4.01	4.04	
Amps	8.4	8.4	8.3	8.0	9.6	9.6	9.6	10.0	11.0	11.0	10.9	11.0	12.5	12.5	12.4	13.0	14.1	14.1	14.1	14.0	16.1	16.1	16.0	16.1	
HI PR	269	270	272	276	310	311	313	318	354	355	357	362	401	402	404	409	452	453	455	459	506	507	509	514	
LO PR	130	132	135	141	138	140	143	148	145	146	150	155	150	152	155	161	156	158	161	166	163	165	168	173	
MBh	41.7	42.3	43.5	45.3	41.4	41.9	43.1	44.9	40.3	40.9	42.1	43.9	38.5	39.1	40.3	42.1	36.4	36.9	38.1	39.9	34.4	34.9	36.1	37.9	
S/T	1.00	1.00	0.88	0.73	1.00	1.00	0.89	0.74	1.00	1.00	0.91	0.76	1.00	1.00	0.93	0.78	1.00	1.00	1.00	0.81	1.00	1.00	1.00	0.86	
ΔT	29	28	24	21	29	28	24	21	30	28	24	21	29	28	24	21	29	27	24	20	30	28	25	21	
KW	2.35	2.35	2.34	2.37	2.62	2.62	2.61	2.63	2.92	2.92	2.91	2.93	3.24	3.24	3.24	3.26	3.61	3.61	3.60	3.62	4.03	4.03	4.03	4.05	
Amps	8.4	8.4	8.4	8.0	9.7	9.6	9.6	10.0	11.0	11.0	11.0	11.0	12.5	12.5	12.5	13.0	14.2	14.2	14.1	14.0	16.1	16.1	16.1	16.2	
HI PR	271	272	274	278	312	314	315	320	356	357	359	364	403	404	406	411	454	455	457	462	508	509	511	516	
LO PR	132	134	137	143	140	142	145	150	147	148	152	157	153	154	157	163	158	160	163	168	165	167	170	175	

IDB: Entering Indoor Dry Bulb Temperature
 High and low pressures are measured at the liquid and suction service valves.
 Shaded area reflects AHRI conditions
 kW = Total system power
 Amps = outdoor unit amps (comp.+fan)

GSX140481K* + CA*F4860*6** + EEP

IDB		OUTDOOR AMBIENT TEMPERATURE												ENTERING INDOOR WET BULB TEMPERATURE													
		65				75				85				95				105				115					
		59	63	67	71	59	63	67	71	59	63	67	71	59	63	67	71	59	63	67	71	59	63	67	71		
70	1400	MBh	46.4	47.1	48.5	-	46.0	46.7	48.0	-	44.8	45.4	46.8	-	42.7	43.4	44.8	-	40.2	40.8	42.2	-	37.9	38.5	39.9	-	
		S/T	0.61	0.54	0.41	-	0.62	0.55	0.41	-	0.65	0.57	0.44	-	0.66	0.59	0.46	-	1.00	0.61	0.48	-	1.00	0.66	0.53	-	
		ΔT	19	17	14	-	19	17	14	-	19	18	14	-	19	17	14	-	19	17	14	-	20	18	15	-	
		KW	2.77	2.77	2.76	-	3.09	3.08	3.08	-	3.44	3.44	3.43	-	3.83	3.82	3.82	-	4.26	4.25	4.25	-	4.76	4.76	4.75	-	
	1550	Amps	10.1	10.1	10.0	-	11.5	11.5	11.5	-	13.2	13.2	13.1	-	14.9	14.9	14.9	-	16.9	16.9	16.9	-	19.2	19.2	19.2	-	
		HI PR	257	259	260	-	298	299	301	-	341	342	343	-	386	387	389	-	436	437	438	-	488	489	491	-	
		LO PR	123	125	128	-	131	132	136	-	137	139	142	-	143	145	148	-	148	150	153	-	155	157	160	-	
		MBh	46.9	47.6	48.9	-	46.5	47.1	48.5	-	45.3	45.9	47.3	-	43.2	43.9	45.2	-	40.7	41.3	42.7	-	38.3	39.0	40.4	-	
	1800	S/T	0.66	0.58	0.45	-	0.66	0.59	0.45	-	0.69	0.61	0.48	-	1.00	0.63	0.50	-	1.00	0.65	0.52	-	1.00	0.71	0.57	-	
		ΔT	18	17	13	-	18	17	13	-	19	17	13	-	18	17	13	-	18	16	13	-	19	17	14	-	
		KW	2.78	2.78	2.77	-	3.10	3.10	3.09	-	3.45	3.45	3.45	-	3.84	3.84	3.83	-	4.27	4.27	4.26	-	4.77	4.77	4.76	-	
		Amps	10.1	10.1	10.1	-	11.6	11.6	11.6	-	13.2	13.2	13.2	-	15.0	15.0	14.9	-	16.9	16.9	16.9	-	19.3	19.2	19.2	-	
1400	HI PR	259	260	262	-	300	301	303	-	342	343	345	-	388	389	391	-	437	438	440	-	490	491	493	-		
	LO PR	125	126	129	-	132	134	137	-	139	140	144	-	144	146	149	-	150	151	154	-	157	158	161	-		
	MBh	47.9	48.5	49.9	-	47.5	48.1	49.5	-	46.2	46.9	48.3	-	44.2	44.8	46.2	-	41.6	42.3	43.7	-	39.3	40.0	41.3	-		
	S/T	0.70	0.62	0.49	-	0.70	0.63	0.49	-	0.73	0.65	0.52	-	1.00	0.67	0.54	-	1.00	0.69	0.56	-	1.00	0.74	0.61	-		
1550	ΔT	17	15	12	-	17	15	12	-	17	16	12	-	17	15	12	-	17	15	12	-	18	16	13	-		
	KW	2.80	2.80	2.79	-	3.12	3.11	3.11	-	3.47	3.47	3.46	-	3.86	3.85	3.85	-	4.29	4.28	4.28	-	4.79	4.79	4.78	-		
	Amps	10.2	10.2	10.2	-	11.7	11.7	11.6	-	13.3	13.3	13.3	-	15.1	15.0	15.0	-	17.0	17.0	17.0	-	19.3	19.3	19.3	-		
	HI PR	262	263	265	-	302	304	305	-	345	346	348	-	391	392	394	-	440	441	443	-	493	494	496	-		
1800	LO PR	127	129	132	-	135	136	140	-	141	143	146	-	147	149	152	-	152	154	157	-	159	161	164	-		
	75	1400	MBh	46.4	47.1	48.5	50.6	46.0	46.7	48.1	50.2	44.8	45.5	46.9	49.0	42.7	43.4	44.8	46.9	40.2	40.9	42.2	44.4	37.9	38.5	39.9	42.0
			S/T	0.74	0.67	0.53	0.39	0.75	0.67	0.54	0.40	1.00	0.70	0.56	0.42	1.00	0.72	0.58	0.44	1.00	0.74	0.60	0.46	1.00	1.00	0.66	0.51
			ΔT	23	21	18	15	23	21	18	14	23	21	18	15	23	21	18	14	23	21	18	14	24	22	19	15
KW			2.77	2.76	2.76	2.78	3.08	3.08	3.08	3.10	3.44	3.44	3.43	3.46	3.82	3.82	3.82	3.84	4.25	4.25	4.25	4.27	4.76	4.76	4.75	4.77	
1550		Amps	10.1	10.1	10.0	10.1	11.5	11.5	11.5	11.6	13.2	13.1	13.1	13.2	14.9	14.9	15.0	15.0	16.9	16.9	16.8	17.0	19.2	19.2	19.1	19.3	
		HI PR	258	259	261	265	298	299	301	306	341	342	344	348	386	388	389	394	436	437	439	443	488	490	491	496	
		LO PR	123	125	128	133	131	132	136	141	137	139	142	147	143	145	148	153	148	150	153	158	155	157	160	165	
		MBh	46.9	47.6	49.0	51.1	46.5	47.2	48.5	50.7	45.3	46.0	47.3	49.5	43.2	43.9	45.3	47.4	40.7	41.3	42.7	44.8	38.4	39.0	40.4	42.5	
1800		S/T	0.79	0.71	0.58	0.44	0.79	0.72	0.58	0.44	1.00	0.74	0.61	0.47	1.00	0.76	0.63	0.49	1.00	0.78	0.65	0.51	1.00	1.00	0.70	0.56	
		ΔT	22	21	17	14	22	20	17	14	23	21	17	14	22	20	17	14	22	20	17	13	23	21	18	15	
		KW	2.78	2.78	2.77	2.80	3.10	3.09	3.09	3.11	3.45	3.45	3.44	3.47	3.84	3.83	3.83	3.85	4.27	4.26	4.26	4.28	4.77	4.77	4.76	4.79	
		Amps	10.1	10.1	10.1	10.2	11.6	11.6	11.5	11.7	13.2	13.2	13.2	13.3	15.0	15.0	14.9	15.0	16.9	16.9	16.9	17.0	19.2	19.2	19.2	19.3	
1400	HI PR	259	260	262	267	300	301	303	307	342	344	345	350	388	389	391	396	437	439	440	445	490	491	493	498		
	LO PR	125	126	129	135	132	134	137	142	139	140	144	149	144	146	149	154	150	151	155	160	157	158	161	167		
	MBh	47.9	48.5	49.9	52.0	47.5	48.1	49.5	51.6	46.3	46.9	48.3	50.4	44.2	44.8	46.2	48.3	41.7	42.3	43.7	45.8	39.3	40.0	41.4	43.5		
	S/T	0.82	0.75	0.62	0.47	1.00	0.76	0.62	0.48	1.00	0.78	0.65	0.50	1.00	0.80	0.67	0.52	1.00	0.82	0.69	0.55	1.00	1.00	0.74	0.60		
1550	ΔT	21	19	16	13	21	19	16	12	21	20	16	13	21	19	16	12	21	19	16	12	22	20	17	13		
	KW	2.80	2.79	2.79	2.81	3.11	3.11	3.11	3.13	3.47	3.47	3.46	3.49	3.85	3.85	3.85	3.87	4.28	4.28	4.28	4.30	4.79	4.79	4.78	4.80		
	Amps	10.2	10.2	10.2	10.3	11.7	11.7	11.6	11.7	13.3	13.3	13.3	13.4	15.1	15.0	15.1	15.1	17.0	17.0	17.0	17.1	19.3	19.3	19.3	19.4		
	HI PR	262	263	265	270	303	304	306	310	345	346	348	353	391	392	394	398	440	441	443	448	493	494	496	500		
1800	LO PR	127	129	132	137	135	136	140	145	142	143	146	151	147	149	152	157	152	154	157	162	159	161	164	169		

IDB: Entering Indoor Dry Bulb Temperature
 High and low pressures are measured at the liquid and suction service valves.
 Shaded area reflects ACCA (TVA) conditions
 kW = Total system power
 Amps = outdoor unit amps (comp.-fan)

GSX140481K* + CA*F4860*6** + EEP (CONT.)

IDB		OUTDOOR AMBIENT TEMPERATURE												ENTERING INDOOR WET BULB TEMPERATURE											
		65				75				85				95				105				115			
		59	63	67	71	59	63	67	71	59	63	67	71	59	63	67	71	59	63	67	71	59	63	67	71
1400	MBh	46.7	47.3	48.7	50.8	46.3	46.9	48.3	50.4	45.1	45.7	47.1	49.2	43.0	43.6	45.0	47.1	40.4	41.1	42.5	44.6	38.1	38.8	40.2	42.3
	S/T	1.00	0.79	0.66	0.5	1.00	0.80	0.66	0.52	1.00	0.82	0.69	0.6	1.00	0.84	0.71	0.57	1.00	1.00	0.73	0.6	1.00	1.00	0.78	0.64
	ΔT	27	25	22	19	27	25	22	18	27	26	22	19	27	25	22	18	27	25	22	18	28	26	23	19
	KW	2.77	2.77	2.76	2.8	3.09	3.08	3.08	3.10	3.44	3.44	3.43	3.5	3.83	3.82	3.82	3.84	4.26	4.25	4.25	4.3	4.76	4.76	4.75	4.78
	Amps	10.1	10.1	10.0	10.2	11.5	11.5	11.5	11.6	13.2	13.1	13.1	13.2	14.9	14.9	14.9	15.0	16.9	16.9	16.9	17.0	19.2	19.2	19.2	19.3
	HI PR	258	259	261	266	299	300	302	306	341	342	344	349	387	388	390	394	436	437	439	444	489	490	492	496
	LO PR	124	125	129	134	131	133	136	141	138	140	143	148	144	145	148	153	149	151	154	159	156	157	160	166
	MBh	47.2	47.8	49.2	51.3	46.8	47.4	48.8	50.9	45.5	46.2	47.6	49.7	43.5	44.1	45.5	47.6	40.9	41.6	43.0	45.1	38.6	39.3	40.6	42.8
	S/T	1.00	0.83	0.70	0.6	1.00	0.84	0.71	0.57	1.00	0.86	0.73	0.6	1.00	1.00	0.75	0.61	1.00	1.00	0.77	0.6	1.00	1.00	0.82	0.68
	ΔT	26	25	21	18	26	24	21	18	27	25	21	18	26	24	21	18	26	24	21	17	27	25	22	18
KW	2.78	2.78	2.77	2.8	3.10	3.10	3.09	3.12	3.45	3.45	3.45	3.5	3.84	3.84	3.83	3.86	4.27	4.27	4.26	4.3	4.77	4.77	4.76	4.79	
Amps	10.1	10.1	10.1	10.2	11.6	11.6	11.6	11.7	13.2	13.2	13.2	13.3	15.0	15.0	14.9	15.1	16.9	16.9	16.9	17.0	19.3	19.2	19.2	19.3	
HI PR	260	261	263	267	300	302	303	308	343	344	346	350	389	390	392	396	438	439	441	445	491	492	493	498	
LO PR	125	127	130	135	133	134	138	143	139	141	144	149	145	146	150	155	150	152	155	160	157	159	162	167	
MBh	48.1	48.8	50.2	52.3	47.7	48.4	49.8	51.9	46.5	47.2	48.5	50.7	44.4	45.1	46.5	48.6	41.9	42.5	43.9	46.0	39.6	40.2	41.6	43.7	
S/T	1.00	0.87	0.74	0.6	1.00	0.88	0.75	0.60	1.00	0.90	0.77	0.6	1.00	1.00	0.79	0.65	1.00	1.00	0.81	0.7	1.00	1.00	0.86	0.72	
ΔT	25	23	20	17	25	23	20	16	25	24	20	17	25	23	20	16	25	23	20	16	26	24	21	17	
KW	2.80	2.80	2.79	2.8	3.12	3.11	3.11	3.13	3.47	3.47	3.46	3.5	3.86	3.85	3.85	3.87	4.29	4.28	4.28	4.3	4.79	4.79	4.78	4.81	
Amps	10.2	10.2	10.2	10.3	11.7	11.7	11.6	11.7	13.3	13.3	13.3	13.4	15.1	15.0	15.0	15.1	17.0	17.0	17.0	17.1	19.3	19.3	19.3	19.4	
HI PR	263	264	266	270	303	304	306	311	346	347	349	353	391	392	394	399	441	442	444	448	493	494	496	501	
LO PR	128	130	133	138	136	137	140	145	142	144	147	152	148	149	152	157	153	155	158	163	160	161	165	170	

1400	MBh	47.5	48.1	49.5	51.6	47.1	47.7	49.1	51.2	45.8	46.5	47.9	50.0	43.8	44.4	45.8	47.9	41.2	41.9	43.3	45.4	38.9	39.6	40.9	43.0
	S/T	1.00	0.89	0.76	0.62	1.00	0.90	0.76	0.62	1.00	1.00	0.79	0.65	1.00	1.00	0.81	0.67	1.00	1.00	0.83	0.69	1.00	1.00	1.00	0.74
	ΔT	31	29	26	22	31	29	25	22	31	29	26	22	31	29	25	22	30	29	25	22	31	30	26	23
	KW	2.77	2.77	2.77	2.79	3.09	3.09	3.08	3.11	3.45	3.45	3.44	3.46	3.83	3.83	3.82	3.85	4.26	4.26	4.25	4.28	4.77	4.76	4.76	4.78
	Amps	10.1	10.1	10.1	10.2	11.6	11.6	11.5	11.6	13.2	13.2	13.2	13.3	14.9	14.9	14.9	15.0	16.9	16.9	16.9	17.0	19.2	19.2	19.2	19.3
	HI PR	259	261	262	267	300	301	303	307	342	344	345	350	388	389	391	396	437	439	440	445	490	491	493	498
	LO PR	126	127	130	136	133	135	138	143	140	141	145	150	145	147	150	155	151	152	155	161	158	159	162	168
	MBh	47.9	48.6	50.0	52.1	47.5	48.2	49.6	51.7	46.3	47.0	48.4	50.5	44.2	44.9	46.3	48.4	41.7	42.4	43.7	45.9	39.4	40.0	41.4	43.5
	S/T	1.00	0.93	0.80	0.66	1.00	1.00	0.81	0.67	1.00	1.00	0.83	0.69	1.00	1.00	0.85	0.71	1.00	1.00	0.87	0.73	1.00	1.00	1.00	0.78
	ΔT	30	28	25	21	30	28	25	21	30	28	25	21	30	28	25	21	30	28	24	21	31	29	26	22
KW	2.79	2.78	2.78	2.80	3.10	3.10	3.10	3.12	3.46	3.46	3.45	3.48	3.84	3.84	3.84	3.86	4.27	4.27	4.27	4.29	4.78	4.78	4.77	4.79	
Amps	10.2	10.2	10.1	10.2	11.6	11.6	11.6	11.7	13.2	13.2	13.2	13.3	15.0	15.0	15.0	15.1	17.0	17.0	16.9	17.0	19.3	19.3	19.3	19.4	
HI PR	261	262	264	268	302	303	305	309	344	345	347	351	390	391	393	397	439	440	442	447	492	493	495	499	
LO PR	127	129	132	137	135	136	139	145	141	143	146	151	147	148	151	157	152	154	157	162	159	161	164	169	
MBh	48.9	49.6	51.0	53.1	48.5	49.2	50.5	52.6	47.3	47.9	49.3	51.4	45.2	45.9	47.2	49.4	42.7	43.3	44.7	46.8	40.3	41.0	42.4	44.5	
S/T	1.00	0.97	0.84	0.70	1.00	1.00	0.85	0.70	1.00	1.00	0.87	0.73	1.00	1.00	0.89	0.75	1.00	1.00	1.00	0.77	1.00	1.00	1.00	0.82	
ΔT	29	27	24	20	29	27	23	20	29	27	24	20	29	27	23	20	28	27	23	20	30	28	24	21	
KW	2.80	2.80	2.80	2.82	3.12	3.12	3.11	3.14	3.48	3.48	3.47	3.49	3.86	3.86	3.85	3.88	4.29	4.29	4.28	4.31	4.80	4.79	4.79	4.81	
Amps	10.2	10.2	10.2	10.3	11.7	11.7	11.7	11.8	13.3	13.3	13.3	13.4	15.1	15.1	15.0	15.2	17.1	17.0	17.0	17.1	19.4	19.3	19.3	19.4	
HI PR	264	265	267	271	304	305	307	312	347	348	350	354	393	394	395	400	442	443	445	449	495	496	497	502	
LO PR	130	131	135	140	137	139	142	147	144	145	149	154	149	151	154	159	155	156	160	165	162	163	166	172	

IDB: Entering Indoor Dry Bulb Temperature
 High and low pressures are measured at the liquid and suction service valves.
 Shaded area reflects AHRI conditions
 kW = Total system power
 Amps = outdoor unit amps (comp.+fan)

GSX140601K* + CA*F4961*6** + EEP + TXV

IDB		OUTDOOR AMBIENT TEMPERATURE												ENTERING INDOOR WET BULB TEMPERATURE														
		65				75				85				95				105				115						
		59	63	67	71	59	63	67	71	59	63	67	71	59	63	67	71	59	63	67	71	59	63	67	71			
70	1550	MBh	58.8	59.6	61.3	-	58.2	59.1	60.8	-	56.7	57.5	59.3	-	54.1	54.9	56.7	-	50.9	51.7	53.5	-	48.0	48.8	50.6	-		
		S/T	0.62	0.55	0.42	-	0.62	0.55	0.43	-	0.65	0.58	0.45	-	0.66	0.59	0.47	-	0.69	0.61	0.49	-	1.00	0.66	0.54	-		
		ΔT	21	19	15	-	21	19	15	-	21	19	15	-	21	19	15	-	21	19	15	-	22	20	16	-		
	1750	KW	3.43	3.42	3.42	-	3.85	3.85	3.84	-	4.33	4.33	4.32	-	4.84	4.84	4.83	-	5.42	5.42	5.41	-	6.09	6.09	6.08	-		
		Amps	13.2	13.2	13.1	-	15.1	15.1	15.1	-	17.3	17.3	17.3	-	19.7	19.6	19.6	-	22.3	22.3	22.2	-	25.4	25.4	25.3	-		
		HI PR	270	271	273	-	312	313	315	-	356	358	359	-	404	405	407	-	455	457	459	-	510	511	513	-		
	2000	LO PR	117	118	121	-	124	125	128	-	130	131	134	-	135	136	139	-	140	141	144	-	146	148	151	-		
		MBh	59.7	60.5	62.3	-	59.2	60.0	61.7	-	57.7	58.5	60.2	-	55.1	55.9	57.6	-	51.9	52.7	54.4	-	49.0	49.8	51.5	-		
		S/T	0.65	0.58	0.45	-	0.66	0.58	0.46	-	0.68	0.61	0.48	-	0.70	0.63	0.50	-	0.72	0.65	0.52	-	1.00	0.69	0.57	-		
	75	1550	ΔT	20	18	14	-	20	18	14	-	20	18	14	-	20	18	14	-	19	17	14	-	21	19	15	-	
			KW	3.47	3.46	3.46	-	3.89	3.89	3.88	-	4.37	4.37	4.36	-	4.88	4.88	4.87	-	5.46	5.46	5.45	-	6.13	6.13	6.12	-	
			Amps	13.4	13.3	13.3	-	15.3	15.3	15.3	-	17.5	17.5	17.4	-	19.8	19.8	19.8	-	22.5	22.5	22.4	-	25.6	25.6	25.5	-	
1750		HI PR	275	276	278	-	317	319	320	-	362	363	365	-	409	410	412	-	461	462	464	-	516	517	519	-		
		LO PR	121	123	126	-	128	130	133	-	134	136	139	-	140	141	144	-	145	146	149	-	151	152	155	-		
		MBh	61.2	62.0	63.7	-	60.6	61.5	63.2	-	59.1	60.0	61.7	-	56.5	57.3	59.1	-	53.3	54.2	55.9	-	50.4	51.3	53.0	-		
2000		S/T	0.66	0.59	0.46	-	0.66	0.59	0.47	-	0.69	0.62	0.49	-	0.71	0.64	0.51	-	1.00	0.66	0.53	-	1.00	0.70	0.58	-		
		ΔT	19	17	13	-	19	17	13	-	19	17	13	-	19	17	13	-	18	16	12	-	20	18	14	-		
		KW	3.47	3.46	3.46	-	3.89	3.89	3.88	-	4.37	4.37	4.36	-	4.88	4.88	4.87	-	5.46	5.46	5.45	-	6.13	6.13	6.12	-		
75		1550	Amps	13.2	13.1	13.1	13.3	15.1	15.1	15.2	-	17.5	17.5	17.4	-	19.8	19.8	19.8	-	22.5	22.5	22.4	-	25.6	25.6	25.5	-	
			HI PR	270	271	273	278	312	314	315	320	-	357	358	360	364	404	405	412	-	456	457	459	463	511	512	514	518
			LO PR	117	118	121	126	124	125	128	133	-	130	131	134	139	135	136	139	144	140	141	144	149	146	148	151	155
	1750	MBh	59.7	60.6	62.3	64.9	59.2	60.0	61.8	64.4	57.7	58.5	60.3	62.9	55.1	55.9	57.6	60.3	51.9	52.7	54.5	57.1	49.0	49.8	51.6	54.2		
		S/T	0.77	0.70	0.57	0.44	0.78	0.70	0.58	0.45	0.80	0.73	0.60	0.47	1.00	0.75	0.62	0.49	1.00	0.77	0.64	0.51	1.00	0.81	0.69	0.56		
		ΔT	24	22	18	15	24	22	18	14	25	23	19	15	24	22	18	14	24	22	18	14	25	23	19	15		
	2000	KW	3.44	3.44	3.43	3.46	3.87	3.87	3.86	3.89	4.34	4.34	4.33	4.37	4.86	4.86	4.85	4.88	5.44	5.43	5.42	5.46	6.11	6.11	6.10	6.13		
		Amps	13.3	13.2	13.2	13.4	15.2	15.2	15.2	15.3	17.4	17.4	17.3	17.5	19.7	19.7	19.7	19.8	22.4	22.4	22.3	22.5	25.5	25.4	25.4	25.6		
		HI PR	272	274	276	280	315	316	318	322	359	360	362	367	407	408	410	414	458	459	461	466	513	514	516	521		
	2000	LO PR	118	120	123	128	125	127	130	135	132	133	136	141	137	138	141	146	142	143	146	151	148	150	153	157		
		MBh	61.2	62.0	63.8	66.4	60.7	61.5	63.2	65.9	59.2	60.0	61.7	64.4	56.6	57.4	59.1	61.8	53.4	54.2	55.9	58.6	50.5	51.3	53.0	55.7		
		S/T	0.78	0.71	0.58	0.45	0.78	0.71	0.59	0.46	1.00	0.74	0.61	0.48	1.00	0.75	0.63	0.50	1.00	0.78	0.65	0.52	1.00	0.82	0.70	0.56		
2000	ΔT	23	21	17	13	23	21	17	13	23	21	18	14	23	21	17	13	23	21	17	13	24	22	18	14			
	KW	3.46	3.46	3.45	3.49	3.89	3.89	3.88	3.91	4.37	4.36	4.36	4.39	4.88	4.88	4.87	4.90	5.46	5.45	5.45	5.48	6.13	6.13	6.12	6.15			
	Amps	13.3	13.3	13.3	13.4	15.3	15.3	15.3	15.4	17.5	17.5	17.4	17.6	19.8	19.8	19.8	19.9	22.5	22.5	22.4	22.6	25.6	25.6	25.5	25.7			
2000	HI PR	275	277	278	283	318	319	321	325	362	363	365	370	410	411	413	417	461	462	464	469	516	517	519	523			
	LO PR	121	123	126	131	128	130	133	138	134	136	139	144	140	141	144	149	145	146	149	154	151	152	155	160			
	MBh	58.8	59.6	61.3	64.0	58.3	59.1	60.8	63.5	56.8	57.6	59.3	62.0	54.1	55.0	56.7	59.3	51.0	51.8	53.5	56.2	48.1	48.9	50.6	53.3			

IDB: Entering Indoor Dry Bulb Temperature
 High and low pressures are measured at the liquid and suction service valves.
 Shaded area reflects ACCA (TVA) conditions
 kW = Total system power
 Amps = outdoor unit amps (comp.-fan)

GSX140601K* + CA*F4961*6** + EEP + TXV (CONT.)

IDB		OUTDOOR AMBIENT TEMPERATURE												ENTERING INDOOR WET BULB TEMPERATURE												
		65				75				85				95				105				115				
		59	63	67	71	59	63	67	71	59	63	67	71	59	63	67	71	59	63	67	71	59	63	67	71	
80	AIRFLOW	MBh	59.1	59.9	61.6	64.3	58.6	59.4	61.1	63.8	57.1	57.9	59.6	62.3	54.4	55.3	57.0	59.6	51.3	52.1	53.8	56.5	48.4	49.2	50.9	53.6
		S/T	0.85	0.78	0.66	0.5	1.00	0.79	0.66	0.53	1.00	0.81	0.69	0.6	1.00	0.83	0.70	0.57	1.00	0.85	0.72	0.6	1.00	1.00	0.77	0.64
		ΔT	30	28	24	20	30	28	24	20	30	28	24	20	30	28	24	20	30	28	24	20	31	29	25	21
	1550	KW	3.43	3.42	3.42	3.5	3.85	3.85	3.84	3.87	4.33	4.32	4.32	4.4	4.84	4.84	4.83	4.87	5.42	5.42	5.41	5.4	6.09	6.09	6.08	6.12
		Amps	13.2	13.2	13.1	13.3	15.1	15.1	15.1	15.2	17.3	17.3	17.3	17.4	19.7	19.6	19.6	19.8	22.3	22.3	22.2	22.4	25.4	25.4	25.3	25.5
		HI PR	271	272	274	278	313	314	316	321	357	358	360	365	405	406	408	413	456	457	459	464	511	512	514	519
	1750	LO PR	117	118	121	126	124	125	128	133	130	132	135	139	135	137	140	145	140	142	145	150	147	148	151	156
		MBh	60.0	60.9	62.6	65.2	59.5	60.3	62.1	64.7	58.0	58.8	60.6	63.2	55.4	56.2	57.9	60.6	52.2	53.0	54.8	57.4	49.3	50.1	51.9	54.5
		S/T	0.89	0.81	0.69	0.6	1.00	0.82	0.70	0.56	1.00	0.84	0.72	0.6	1.00	0.86	0.74	0.60	1.00	0.88	0.76	0.6	1.00	1.00	0.80	0.67
	2000	ΔT	29	27	23	19	29	27	23	19	29	27	23	19	29	27	23	19	29	26	23	19	30	28	24	20
KW		3.44	3.44	3.43	3.5	3.87	3.87	3.86	3.89	4.35	4.34	4.34	4.4	4.86	4.86	4.85	4.88	5.44	5.43	5.43	5.5	6.11	6.11	6.10	6.13	
Amps		13.3	13.2	13.2	13.4	15.2	15.2	15.2	15.3	17.4	17.4	17.3	17.5	19.7	19.7	19.7	19.8	22.4	22.4	22.3	22.5	25.5	25.5	25.4	25.6	
1550	HI PR	273	274	276	281	315	316	318	323	359	361	362	367	407	408	410	415	458	460	462	466	513	514	516	521	
	LO PR	119	120	123	128	126	127	130	135	132	134	136	141	137	139	142	146	142	144	147	152	149	150	153	158	
	MBh	61.5	62.3	64.1	66.7	61.0	61.8	63.5	66.2	59.5	60.3	62.0	64.7	56.9	57.7	59.4	62.1	53.7	54.5	56.2	58.9	50.8	51.6	53.3	56.0	
2000	S/T	0.89	0.82	0.70	0.6	1.00	0.83	0.70	0.57	1.00	0.85	0.73	0.6	1.00	0.87	0.75	0.61	1.00	1.00	0.77	0.6	1.00	1.00	0.81	0.68	
	ΔT	28	26	22	18	28	26	22	18	28	26	22	18	28	26	22	18	27	25	21	18	29	27	23	19	
	KW	3.47	3.46	3.46	3.5	3.89	3.89	3.88	3.91	4.37	4.36	4.36	4.4	4.88	4.88	4.87	4.90	5.46	5.46	5.45	5.5	6.13	6.13	6.12	6.16	
1550	Amps	13.4	13.3	13.3	13.5	15.3	15.3	15.3	15.4	17.5	17.5	17.4	17.6	19.8	19.8	19.8	19.9	22.5	22.5	22.4	22.6	25.6	25.6	25.5	25.7	
	HI PR	276	277	279	284	318	319	321	326	362	364	365	370	410	411	413	418	461	463	464	469	516	517	519	524	
	LO PR	122	123	126	131	129	130	133	138	135	136	139	144	140	142	144	149	145	147	150	154	152	153	156	161	
85	AIRFLOW	MBh	60.1	60.9	62.6	65.3	59.5	60.4	62.1	64.7	58.0	58.8	60.6	63.2	55.4	56.2	58.0	60.6	52.2	53.1	54.8	57.4	49.3	50.2	51.9	54.5
		S/T	1.00	0.88	0.75	0.62	1.00	0.88	0.76	0.62	1.00	0.91	0.78	0.65	1.00	1.00	0.80	0.67	1.00	1.00	0.82	0.69	1.00	1.00	0.87	0.73
		ΔT	34	32	28	24	34	32	28	24	34	32	28	24	34	32	28	24	34	32	28	24	35	33	29	25
	1750	KW	3.43	3.43	3.42	3.46	3.86	3.86	3.85	3.88	4.34	4.33	4.33	4.36	4.85	4.85	4.84	4.87	5.43	5.42	5.42	5.45	6.10	6.10	6.09	6.12
		Amps	13.2	13.2	13.2	13.3	15.2	15.1	15.1	15.3	17.3	17.3	17.3	17.4	19.7	19.7	19.7	19.8	22.3	22.3	22.3	22.4	25.4	25.4	25.4	25.5
		HI PR	272	273	275	280	314	315	317	322	358	360	361	366	406	407	409	414	457	459	460	465	512	513	515	520
	2000	LO PR	119	120	123	128	126	127	130	135	132	133	136	141	137	138	141	146	142	144	146	151	148	150	153	158
		MBh	61.0	61.8	63.6	66.2	60.5	61.3	63.0	65.7	59.0	59.8	61.5	64.2	56.4	57.2	58.9	61.6	53.2	54.0	55.7	58.4	50.3	51.1	52.8	55.5
		S/T	1.00	0.91	0.78	0.65	1.00	0.91	0.79	0.66	1.00	0.94	0.81	0.68	1.00	1.00	0.83	0.70	1.00	1.00	0.85	0.72	1.00	1.00	0.90	0.77
	1550	ΔT	33	31	27	23	33	31	27	23	33	31	27	23	33	31	27	23	33	31	27	23	34	32	28	24
KW		3.45	3.45	3.44	3.48	3.88	3.88	3.87	3.90	4.36	4.35	4.34	4.38	4.87	4.87	4.86	4.89	5.45	5.44	5.44	5.47	6.12	6.12	6.11	6.14	
Amps		13.3	13.3	13.3	13.4	15.3	15.2	15.2	15.4	17.4	17.4	17.4	17.5	19.8	19.8	19.7	19.9	22.4	22.4	22.4	22.5	25.5	25.5	25.5	25.6	
2000	HI PR	274	275	277	282	316	318	319	324	361	362	364	368	408	410	411	416	460	461	463	467	515	516	518	522	
	LO PR	121	122	125	130	128	129	132	137	134	135	138	143	139	140	143	148	144	145	148	153	150	152	155	160	
	MBh	62.5	63.3	65.0	67.7	62.0	62.8	64.5	67.2	60.4	61.3	63.0	65.6	57.8	58.7	60.4	63.0	54.7	55.5	57.2	59.9	51.7	52.6	54.3	56.9	
1550	S/T	1.00	0.92	0.79	0.66	1.00	0.92	0.80	0.67	1.00	1.00	0.82	0.69	1.00	1.00	0.84	0.71	1.00	1.00	0.86	0.73	1.00	1.00	0.91	0.77	
	ΔT	32	30	26	22	32	30	26	22	32	30	26	22	32	30	26	22	31	29	26	22	33	31	27	23	
	KW	3.47	3.47	3.46	3.50	3.90	3.90	3.89	3.92	4.38	4.37	4.37	4.40	4.89	4.89	4.88	4.91	5.47	5.46	5.46	5.49	6.14	6.14	6.13	6.16	
2000	Amps	13.4	13.4	13.3	13.5	15.3	15.3	15.3	15.4	17.5	17.5	17.5	17.6	19.9	19.9	19.8	20.0	22.5	22.5	22.5	22.6	25.6	25.6	25.6	25.7	
	HI PR	277	278	280	285	319	321	322	327	364	365	367	371	411	412	414	419	463	464	466	470	518	519	521	525	
	LO PR	124	125	128	133	131	132	135	140	137	138	141	146	142	143	146	151	147	148	151	156	153	155	158	162	

kW = Total system power
Amps = outdoor unit amps (comp.+fan)

Shaded area reflects AHRI conditions

IDB: Entering Indoor Dry Bulb Temperature
High and low pressures are measured at the liquid and suction service valves.

PERFORMANCE DATA

GSX140181K* / CA*F3636*6** W/.052" ORIFICE CONDITIONS: 80 °F IBD, 67 °F IWB @ 600 CFM				
OUTDOOR TEM. ° F.	TOTAL BTU/H	SENSIBLE BTU/H	LATENT BTU/H	TOTAL WATTS
75	19,300	13,124	6,176	1,220
80	19,050	13,142	5,908	1,290
85	18,800	13,160	5,640	1,360
90	18,400	13,060	5,340	1,435
95	18,000	12,960	5,040	1,510
100	17,500	12,770	4,730	1,595
105	17,000	12,580	4,420	1,680
110	16,550	12,650	3,901	1,780
115	16,100	12,719	3,381	1,880
TVA CONDITIONS @ 95° OD DB, 75° ID DB 63° ID WB				
95°	17,400	12,700	4,700	1,510

GSX140191K* / CA*F3636*6** W/.053" ORIFICE CONDITIONS: 80 °F IBD, 67 °F IWB @ 550 CFM				
OUTDOOR TEM. ° F.	TOTAL BTU/H	SENSIBLE BTU/H	LATENT BTU/H	TOTAL WATTS
75	18,900	13,041	5,859	1,160
80	18,650	13,145	5,506	1,225
85	18,400	13,248	5,152	1,290
90	18,000	13,136	4,864	1,360
95	17,600	13,024	4,576	1,430
100	17,100	12,820	4,280	1,530
105	16,600	12,616	3,984	1,590
110	16,150	12,667	3,484	1,680
115	15,700	12,717	2,983	1,770
TVA CONDITIONS @ 95° OD DB, 75° ID DB 63° ID WB				
95°	17,000	12,750	4,250	1,430

GSX140241K* / CA*F3636*6** W/.057" ORIFICE CONDITIONS: 80 °F IBD, 67 °F IWB @ 700 CFM				
OUTDOOR TEM. ° F.	TOTAL BTU/H	SENSIBLE BTU/H	LATENT BTU/H	TOTAL WATTS
75	24,877	16,961	7,916	1,554
80	24,568	17,040	7,528	1,644
85	24,260	17,120	7,140	1,735
90	23,730	16,961	6,769	1,833
95	23,200	16,802	6,397	1,931
100	22,552	16,564	5,988	2,040
105	21,904	16,326	5,578	2,149
110	21,312	16,393	4,919	2,278
115	20,721	16,461	4,260	2,406
TVA CONDITIONS @ 95° OD DB, 75° ID DB 63° ID WB				
95°	22,400	16,802	5,598	1,931

GSX140251K* / CA*F3636*6** W/.057" ORIFICE CONDITIONS: 80 °F IBD, 67 °F IWB @ 700 CFM				
OUTDOOR TEM. ° F.	TOTAL BTU/H	SENSIBLE BTU/H	LATENT BTU/H	TOTAL WATTS
75	25,500	17,085	8,415	1,570
80	25,200	17,258	7,943	1,660
85	24,900	17,430	7,470	1,750
90	24,350	17,283	7,067	1,850
95	23,800	17,136	6,664	1,950
100	23,150	16,893	6,257	2,060
105	22,500	16,650	5,850	2,170
110	21,900	16,739	5,162	2,300
115	21,300	16,827	4,473	2,430
TVA Conditions @ 95° OD DB, 75° ID DB 63° ID WB				
95°	23,000	16,790	6,210	1,950

GSX140301K* / CA*F3642*6** W/.065" ORIFICE CONDITIONS: 80 °F IBD, 67 °F IWB @ 1000 CFM				
OUTDOOR TEM. ° F.	TOTAL BTU/H	SENSIBLE BTU/H	LATENT BTU/H	TOTAL WATTS
75	30,900	21,630	9,270	1,960
80	30,500	21,651	8,849	2,070
85	30,100	21,672	8,428	2,180
90	29,450	21,492	7,958	2,300
95	28,800	21,312	7,488	2,420
100	28,000	20,992	7,008	2,550
105	27,200	20,672	6,528	2,680
110	26,450	20,745	5,706	2,840
115	25,700	20,817	4,883	3,000
TVA Conditions @ 95° OD DB, 75° ID DB 63° ID WB				
95°	27,800	20,850	6,950	2,420

GSX140311K* / CA*F3137*6** W/.063" ORIFICE CONDITIONS: 80 °F IBD, 67 °F IWB @ 1000 CFM				
OUTDOOR TEM. ° F.	TOTAL BTU/H	SENSIBLE BTU/H	LATENT BTU/H	TOTAL WATTS
75	30,700	22,718	7,982	1,920
80	30,300	22,871	7,430	2,025
85	29,900	23,023	6,877	2,130
90	29,250	22,809	6,442	2,245
95	28,600	22,594	6,006	2,360
100	27,800	22,232	5,568	2,490
105	27,000	21,870	5,130	2,620
110	26,250	21,900	4,350	2,770
115	25,500	21,930	3,570	2,920
TVA Conditions @ 95° OD DB, 75° ID DB 63° ID WB				
95°	27,600	20,080	5,520	2,360

PERFORMANCE DATA (CONT.)

GSX140361K* / CA*F3642*6** W/.068" Orifice Conditions: 80 °F IBD, 67 °F IWB @ 1200 CFM				
Outdoor Tem. ° F.	Total Btuh	Sensible Btuh	Latent Btuh	Total Watts
75	36,700	25,690	11,010	2,330
80	36,250	25,733	10,517	2,460
85	35,800	25,776	10,024	2,590
90	35,000	25,542	9,458	2,730
95	34,200	25,308	8,892	2,870
100	33,250	24,928	8,322	3,030
105	32,300	24,548	7,752	3,190
110	31,400	24,627	6,774	3,370
115	30,500	24,705	5,795	3,550
TVA Conditions @ 95° OD DB, 75° ID DB 63° ID WB				
95°	33,000	24,750	8,250	2,870

GSX140371K* / CA*F3137*6** W/.071" Orifice Conditions: 80 °F IBD, 67 °F IWB @ 1100 CFM				
Outdoor Tem. ° F.	Total Btuh	Sensible Btuh	Latent Btuh	Total Watts
75	36,500	25,915	10,585	2,260
80	36,050	26,130	9,921	2,400
85	35,600	26,344	9,256	2,540
90	34,800	26,092	8,708	2,675
95	34,000	25,840	8,160	2,810
100	33,050	25,439	7,611	2,970
105	32,100	25,038	7,062	3,130
110	31,250	25,135	6,115	3,315
115	30,400	25,232	5,168	3,500
TVA Conditions @ 95° OD DB, 75° ID DB 63° ID WB				
95°	32,800	25,256	7,544	2,810

GSX140421K* / CA*F4961*6** W/.074" Orifice Conditions: 80 °F IBD, 67 °F IWB @ 1400 CFM				
Outdoor Tem. ° F.	Total Btuh	Sensible Btuh	Latent Btuh	Total Watts
75	41,800	30,932	10,868	2,600
80	41,300	31,174	10,126	2,750
85	40,800	31,416	9,384	2,900
90	39,900	31,113	8,787	3,060
95	39,000	30,810	8,190	3,220
100	37,900	30,309	7,591	3,400
105	36,800	29,808	6,992	3,580
110	35,800	30,042	5,758	3,795
115	34,800	30,276	4,524	4,010
TVA Conditions @ 95° OD DB, 75° ID DB 63° ID WB				
95°	37,600	30,080	7,520	3,220

GSX140481K / CA*F4860*6** W/.078" Orifice Conditions: 80 °F IBD, 67 °F IWB @ 1400 CFM				
Outdoor Tem. ° F.	Total Btuh	Sensible Btuh	Latent Btuh	Total Watts
75	48,300	31,878	16,422	3,080
80	47,700	32,189	15,511	3,255
85	47,100	32,500	14,600	3,430
90	46,050	32,225	13,825	3,625
95	45,000	31,950	13,050	3,820
100	43,750	31,488	12,263	4,035
105	42,500	31,025	11,475	4,250
110	41,350	31,191	10,160	4,500
115	40,200	31,356	8,844	4,750
TVA Conditions @ 95° OD DB, 75° ID DB 63° ID WB				
95°	43,400	31,248	12,152	3,820

GSX140601K* / CA*F4961*6** W/.088" Orifice Conditions: 80 °F IBD, 67 °F IWB @ 1550 CFM				
Outdoor Tem. ° F.	Total Btuh	Sensible Btuh	Latent Btuh	Total Watts
75	61,100	40,326	20,774	3,840
80	60,350	40,725	19,625	4,080
85	59,600	41,124	18,476	4,320
90	58,300	40,512	17,788	4,575
95	57,000	39,900	17,100	4,830
100	55,400	39,318	16,082	5,120
105	53,800	38,736	15,064	5,410
110	52,350	38,965	13,386	5,745
115	50,900	39,193	11,707	6,080
TVA Conditions @ 95° OD DB, 75° ID DB 63° ID WB				
95°	55,000	39,050	15,950	4,840

OUTDOOR UNIT	INDOOR UNITS		COOLING RATINGS				CFM	AHRI #
	COILS/AIR HANDLERS	FURNACES	TOTAL ¹	SENS. ¹	SEER ²	EER ³		
GSX14 0181K*	ASPT24B14A*		18,000	13,000	14.50	12.00	605	7515631
	ASPT30C14A*		18,400	13,300	14.50	12.00	580	7515632
	AVPTC24B14A*		18,000	13,000	14.50	12.00	600	7515633
	AVPTC30C14A*		18,400	13,300	14.50	12.00	615	7515634
	AWUF31XX16A*		17,400	12,500	14.50	11.50	600	7515635
	AWUF32XX16A*		17,400	12,500	14.50	11.50	600	7515636
	CA*F3636*6D*+EEP+TXV		17,800	12,800	14.00	11.50	600	7515637
	CA*F3636*6D*+MBVC1200**-1A*+TXV		17,800	12,800	14.50	11.50	600	7515659
	CA*F3636*6D*+TXV	G*VC960403BNA*	18,000	13,000	14.50	11.50	615	7515654
	CA*F3636*6D*+TXV	G*EC960603BNA*	17,800	12,800	14.50	11.50	500	7515651
	CA*F3636*6D*+TXV	G*EC960302BNA*	17,800	12,800	14.50	11.50	575	7515649
	CA*F3636*6D*+TXV	G*EC960402BNA*	17,800	12,800	14.50	11.50	575	7515650
	CA*F3636*6D*+TXV	A*VC80604B*B*	18,000	13,000	14.50	11.50	620	7515642
	CA*F3636*6D*+TXV	G*VC960603BNA*	18,000	13,000	14.50	11.50	625	7515655
	CA*F3636*6D*+TXV	A*VC960603BNA*	18,000	13,000	14.50	11.50	625	7515644
	CA*F3636*6D*+TXV	G*E80603B*B*	18,000	13,000	14.50	11.50	670	7515648
	CA*F3636*6D*+TXV	A*VC960803BNA*	18,000	13,000	14.50	11.50	620	7515645
	CA*F3636*6D*+TXV	A*EC960803BNA*	17,800	12,800	14.50	11.50	540	7515641
	CA*F3636*6D*+TXV	G*EC960803BNA*	17,800	12,800	14.50	11.50	540	7515652
	CA*F3636*6D*+TXV	G*VC960803BNA*	18,000	13,000	14.50	11.50	620	7515656
	CA*F3636*6D*+TXV	A*EC960302BNA*	17,800	12,800	14.50	11.50	575	7515638
	CA*F3636*6D*+TXV	A*VM970603BNA*	18,000	13,000	14.50	11.50	625	7515646
	CA*F3636*6D*+TXV	A*EC960603BNA*	17,800	12,800	14.50	11.50	500	7515640
	CA*F3636*6D*+TXV	G*VC80604B*B*	18,000	13,000	14.50	11.50	620	7515653
	CA*F3636*6D*+TXV	A*EC960402BNA*	17,800	12,800	14.50	11.50	575	7515639
	CA*F3636*6D*+TXV	G*VM970804CNA*	18,000	13,000	14.50	11.50	620	7515658
	CA*F3636*6D*+TXV	G*VM970603BNA*	18,000	13,000	14.50	11.50	625	7515657
	CA*F3636*6D*+TXV	A*VM970804CNA*	18,000	13,000	14.50	11.50	620	7515647
	CA*F3636*6D*+TXV	A*VC960403BNA*	18,000	13,000	14.50	11.50	615	7515643
	CA*F3743*6D*+EEP+TXV		18,000	13,000	14.50	11.50	600	7515660
	CAPT3743*4A*	G*VM970804CNA*	18,000	13,000	14.50	11.50	620	7515682
	CAPT3743*4A*	A*EC960803BNA*	17,800	12,800	14.50	11.50	540	7515665
	CAPT3743*4A*	A*VM970804CNA*	18,000	13,000	14.50	11.50	620	7515671
	CAPT3743*4A*	G*VC80604B*B*	18,000	13,000	14.50	11.50	620	7515677
	CAPT3743*4A*	G*EC960803BNA*	17,800	12,800	14.50	11.50	540	7515676
	CAPT3743*4A*	G*VC960403BNA*	18,000	13,000	14.50	11.50	615	7515678
	CAPT3743*4A*	G*VM970603BNA*	18,000	13,000	14.50	11.50	625	7515681
	CAPT3743*4A*	A*VC960403BNA*	18,000	13,000	14.50	11.50	615	7515667
	CAPT3743*4A*	G*E80603B*B*	18,000	13,000	14.50	11.50	670	7515672
	CAPT3743*4A*	G*EC960402BNA*	17,800	12,800	14.50	11.50	575	7515674
	CAPT3743*4A*	A*EC960302BNA*	17,800	12,800	14.50	11.50	575	7515662
	CAPT3743*4A*	A*EC960603BNA*	17,800	12,800	14.50	11.50	500	7515664
	CAPT3743*4A*	A*VC960603BNA*	18,000	13,000	14.50	11.50	625	7515668
	CAPT3743*4A*	G*EC960603BNA*	17,800	12,800	14.50	11.50	500	7515675
	CAPT3743*4A*	G*EC960302BNA*	17,800	12,800	14.50	11.50	575	7515673
	CAPT3743*4A*	G*VC960603BNA*	18,000	13,000	14.50	11.50	625	7515679
	CAPT3743*4A*	G*VC960803BNA*	18,000	13,000	14.50	11.50	620	7515680
	CAPT3743*4A*	A*EC960402BNA*	17,800	12,800	14.50	11.50	575	7515663
	CAPT3743*4A*	A*VC960803BNA*	18,000	13,000	14.50	11.50	620	7515669
	CAPT3743*4A*	A*VC80604B*B*	18,000	13,000	14.50	11.50	620	7515666
CAPT3743*4A*	A*VM970603BNA*	18,000	13,000	14.50	11.50	625	7515670	
CAPT3743*4A*+EEP		17,800	12,800	14.00	11.50	550	7515661	
CAPT3743*4A*+MBVC1200**-1A*		17,400	12,500	14.50	12.00	535	7515683	

See Notes on Page 30.

OUTDOOR UNIT	INDOOR UNITS		COOLING RATINGS				CFM	AHRI #
	COILS/AIR HANDLERS	FURNACES	TOTAL ¹	SENS. ¹	SEER ²	EER ³		
GSX14 0181K* (cont.)	CHPF2430B6C*+EEP+TXV		17,800	12,800	14.00	11.50	600	7515684
	CHPF2430B6C*+MBVC1200**-1A*+TXV		17,800	12,800	14.50	11.50	600	7515685
	CHPF2430B6C*+TXV	A*VC80604B*B*	18,000	13,000	14.50	11.50	620	7515686
	CHPF2430B6C*+TXV	G*VC80604B*B*	18,000	13,000	14.50	11.50	620	7515687
	CHPF3636B6C*+EEP+TXV		18,000	13,000	14.50	11.50	600	7515688
	CHPF3636B6C*+TXV	G*VC960603BNA*	18,000	13,000	14.50	11.50	625	7515704
	CHPF3636B6C*+TXV	G*EC960402BNA*	17,800	12,800	14.50	11.50	575	7515700
	CHPF3636B6C*+TXV	A*VC960603BNA*	18,000	13,000	14.50	11.50	625	7515694
	CHPF3636B6C*+TXV	A*EC960402BNA*	17,800	12,800	14.50	11.50	575	7515690
	CHPF3636B6C*+TXV	A*EC960302BNA*	17,800	12,800	14.50	11.50	575	7515689
	CHPF3636B6C*+TXV	G*VM970603BNA*	18,000	13,000	14.50	11.50	625	7515706
	CHPF3636B6C*+TXV	A*EC960603BNA*	17,800	12,800	14.50	11.50	500	7515691
	CHPF3636B6C*+TXV	A*VC960803BNA*	18,000	13,000	14.50	11.50	620	7515695
	CHPF3636B6C*+TXV	G*EC960803BNA*	17,800	12,800	14.50	11.50	540	7515702
	CHPF3636B6C*+TXV	G*VC960803BNA*	18,000	13,000	14.50	11.50	620	7515705
	CHPF3636B6C*+TXV	A*VC960403BNA*	18,000	13,000	14.50	11.50	615	7515693
	CHPF3636B6C*+TXV	A*VM970804CNA*	18,000	13,000	14.50	11.50	620	7515697
	CHPF3636B6C*+TXV	G*EC960603BNA*	17,800	12,800	14.50	11.50	500	7515701
	CHPF3636B6C*+TXV	G*VM970804CNA*	18,000	13,000	14.50	11.50	620	7515707
	CHPF3636B6C*+TXV	G*E80603B*B*	18,000	13,000	14.50	11.50	670	7515698
	CHPF3636B6C*+TXV	A*VM970603BNA*	18,000	13,000	14.50	11.50	625	7515696
	CHPF3636B6C*+TXV	G*VC960403BNA*	18,000	13,000	14.50	11.50	615	7515703
	CHPF3636B6C*+TXV	A*EC960803BNA*	17,800	12,800	14.50	11.50	540	7515692
	CHPF3636B6C*+TXV	G*EC960302BNA*	17,800	12,800	14.50	11.50	575	7515699
	CSCF3036N6D*+EEP+TXV		17,800	12,800	14.00	11.50	600	7515708
	CSCF3036N6D*+TXV	G*VM970603BNA*	18,000	13,000	14.50	11.50	625	7515727
	CSCF3036N6D*+TXV	G*EC960402BNA*	17,800	12,800	14.50	11.50	575	7515721
	CSCF3036N6D*+TXV	G*VC960403BNA*	18,000	13,000	14.50	11.50	615	7515724
	CSCF3036N6D*+TXV	G*VM970804CNA*	18,000	13,000	14.50	11.50	620	7515728
	CSCF3036N6D*+TXV	A*EC960603BNA*	17,800	12,800	14.50	11.50	500	7515713
	CSCF3036N6D*+TXV	G*EC960803BNA*	17,800	12,800	14.50	11.50	540	7515723
	CSCF3036N6D*+TXV	A*VM970603BNA*	18,000	13,000	14.50	11.50	625	7515718
	CSCF3036N6D*+TXV	G*VC960803BNA*	18,000	13,000	14.50	11.50	620	7515726
	CSCF3036N6D*+TXV	G*VC960603BNA*	18,000	13,000	14.50	11.50	625	7515725
	CSCF3036N6D*+TXV	A*VC960403BNA*	18,000	13,000	14.50	11.50	615	7515715
	CSCF3036N6D*+TXV	G*EC960302BNA*	17,800	12,800	14.50	11.50	575	7515720
	CSCF3036N6D*+TXV	A*EC960803BNA*	17,800	12,800	14.50	11.50	540	7515714
	CSCF3036N6D*+TXV	A*VC960603BNA*	18,000	13,000	14.50	11.50	625	7515716
	CSCF3036N6D*+TXV	A*EC960402BNA*	17,800	12,800	14.50	11.50	575	7515712
	CSCF3036N6D*+TXV	A*VC960803BNA*	18,000	13,000	14.50	11.50	620	7515717
CSCF3036N6D*+TXV	A*EC960302BNA*	17,800	12,800	14.50	11.50	575	7515711	
CSCF3036N6D*+TXV	A*VC80604B*B*	18,000	13,000	14.50	11.50	620	7515709	
CSCF3036N6D*+TXV	G*VC80604B*B*	18,000	13,000	14.50	11.50	620	7515710	
CSCF3036N6D*+TXV	A*VM970804CNA*	18,000	13,000	14.50	11.50	620	7515719	
CSCF3036N6D*+TXV	G*EC960603BNA*	17,800	12,800	14.50	11.50	500	7515722	
CSCF3642N6D*+EEP+TXV		18,000	13,000	14.50	11.50	600	7515729	

¹ BTU/h

² Seasonal Energy Efficiency Ratio; Certified per AHRI 210/240 @ 80°F/ 67°F/ 95°F

³ Energy Efficiency Ratio @ 80°F/ 67°F/ 95°F

NOTES

- Always check the S&R plate for electrical data on the unit being installed.
- When matching the outdoor unit to the indoor unit, use the piston supplied with the outdoor unit or that specified on the piston kit chart supplied with the indoor unit.
- EEP - Order from Service Dept. Part No. B13707-38 or new Solid State Board B13707-35S. Part No. B13707-38 is not interchangeable with B13707-35S. The Goodman Gas Furnace contains the EEP cooling time delay

OUTDOOR UNIT	INDOOR UNITS		COOLING RATINGS				CFM	AHRI #
	COILS/AIR HANDLERS	FURNACES	TOTAL ¹	SENS. ¹	SEER ²	EER ³		
GSX14 0191K*	ASPT24B14A*		17,800	13,100	14.50	12.20	525	7515730
	ASPT30C14A*		18,000	13,300	15.00	12.50	600	7515731
	AVPTC24B14A*		17,800	13,100	14.50	12.20	600	7515732
	AVPTC30C14A*		18,200	13,400	15.00	12.50	615	7515733
	AWUF31XX16A*		17,200	12,700	15.00	12.50	550	7515734
	AWUF32XX16A*		17,200	12,700	15.00	12.50	550	7515735
	CA*F3636*6D*+EEP+TXV		17,600	13,000	14.00	12.20	550	7515736
	CA*F3636*6D*+MBVC1200**-1A*+TXV		18,000	13,300	15.00	12.50	600	7515737
	CA*F3636*6D*+TXV	G*EC960302BNA*	17,800	13,100	15.00	12.50	575	7515749
	CA*F3636*6D*+TXV	G*EC960603BNA*	17,800	13,100	15.00	12.50	500	7515751
	CA*F3636*6D*+TXV	G*VC960603BNA*	17,800	13,100	15.00	12.50	625	7515755
	CA*F3636*6D*+TXV	G*E80603B*B*	17,800	13,100	15.00	12.50	600	7515748
	CA*F3636*6D*+TXV	A*VC960603BNA*	17,800	13,100	15.00	12.50	625	7515744
	CA*F3636*6D*+TXV	A*EC960402BNA*	17,800	13,100	15.00	12.50	575	7515739
	CA*F3636*6D*+TXV	G*VC960403BNA*	17,800	13,100	15.00	12.50	615	7515754
	CA*F3636*6D*+TXV	G*VC960803BNA*	17,800	13,100	15.00	12.50	620	7515756
	CA*F3636*6D*+TXV	A*VC960803BNA*	17,800	13,100	15.00	12.50	620	7515745
	CA*F3636*6D*+TXV	G*VM970603BNA*	17,800	13,100	15.00	12.50	625	7515757
	CA*F3636*6D*+TXV	A*VC960403BNA*	17,800	13,100	15.00	12.50	615	7515743
	CA*F3636*6D*+TXV	G*VC80604B*B*	17,800	13,100	15.00	12.50	620	7515753
	CA*F3636*6D*+TXV	G*EC960402BNA*	17,800	13,100	15.00	12.50	575	7515750
	CA*F3636*6D*+TXV	A*VM970603BNA*	17,800	13,100	15.00	12.50	625	7515746
	CA*F3636*6D*+TXV	G*VM970804CNA*	17,800	13,100	15.00	12.50	620	7515758
	CA*F3636*6D*+TXV	G*EC960803BNA*	17,800	13,100	15.00	12.50	540	7515752
	CA*F3636*6D*+TXV	A*EC960603BNA*	17,800	13,100	15.00	12.50	500	7515740
	CA*F3636*6D*+TXV	A*EC960803BNA*	17,800	13,100	15.00	12.50	540	7515741
	CA*F3636*6D*+TXV	A*VM970804CNA*	17,800	13,100	15.00	12.50	620	7515747
	CA*F3636*6D*+TXV	A*EC960302BNA*	17,800	13,100	15.00	12.50	575	7515738
	CA*F3636*6D*+TXV	A*VC80604B*B*	17,800	13,100	15.00	12.50	620	7515742
	CA*F3743*6D*+EEP+TXV		18,000	13,300	14.50	12.20	550	7515759
	CAPT3743*4A*	A*EC960402BNA*	17,800	13,100	15.00	12.50	575	7515763
	CAPT3743*4A*	G*EC960302BNA*	17,800	13,100	15.00	12.50	575	7515773
	CAPT3743*4A*	G*VM970804CNA*	17,800	13,100	15.00	12.50	620	7515782
	CAPT3743*4A*	A*VC80604B*B*	17,800	13,100	15.00	12.50	620	7515766
	CAPT3743*4A*	A*VM970603BNA*	17,800	13,100	15.00	12.50	625	7515770
	CAPT3743*4A*	A*EC960302BNA*	17,800	13,100	15.00	12.50	575	7515762
	CAPT3743*4A*	A*VC960603BNA*	17,800	13,100	15.00	12.50	625	7515768
	CAPT3743*4A*	G*VC960403BNA*	17,800	13,100	15.00	12.50	615	7515778
	CAPT3743*4A*	G*VC960803BNA*	17,800	13,100	15.00	12.50	620	7515780
	CAPT3743*4A*	G*EC960803BNA*	17,800	13,100	15.00	12.50	540	7515776
	CAPT3743*4A*	A*EC960803BNA*	17,800	13,100	15.00	12.50	540	7515765
	CAPT3743*4A*	G*EC960402BNA*	17,800	13,100	15.00	12.50	575	7515774
	CAPT3743*4A*	G*EC960603BNA*	17,800	13,100	15.00	12.50	500	7515775
	CAPT3743*4A*	G*VM970603BNA*	17,800	13,100	15.00	12.50	625	7515781
	CAPT3743*4A*	A*VC960803BNA*	17,800	13,100	15.00	12.50	620	7515769
	CAPT3743*4A*	G*VC960603BNA*	17,800	13,100	15.00	12.50	625	7515779
	CAPT3743*4A*	A*EC960603BNA*	17,800	13,100	15.00	12.50	500	7515764
CAPT3743*4A*	G*VC80604B*B*	17,800	13,100	15.00	12.50	620	7515777	
CAPT3743*4A*	G*E80603B*B*	17,800	13,100	15.00	12.50	600	7515772	
CAPT3743*4A*	A*VM970804CNA*	17,800	13,100	15.00	12.50	620	7515771	
CAPT3743*4A*	A*VC960403BNA*	17,800	13,100	15.00	12.50	615	7515767	
CAPT3743*4A*+EEP		17,600	13,000	14.00	12.20	550	7515760	

See Notes on Page 30.

OUTDOOR UNIT	INDOOR UNITS		COOLING RATINGS				CFM	AHRI #
	COILS/AIR HANDLERS	FURNACES	TOTAL ¹	SENS. ¹	SEER ²	EER ³		
GSX14 0191K* (cont.)	CAPT3743*4A*+MBVC1200**-1A*		17,800	13,100	15.00	12.50	600	7515761
	CHPF3636B6C*+EEP+TXV		17,600	13,000	14.50	12.20	550	7515783
	CHPF3636B6C*+MBVC1200**-1A*+TXV		18,200	13,400	15.00	12.50	600	7515784
	CHPF3636B6C*+TXV	A*VM970603BNA*	17,800	13,100	15.00	12.50	625	7515793
	CHPF3636B6C*+TXV	A*VM970804CNA*	17,800	13,100	15.00	12.50	620	7515794
	CHPF3636B6C*+TXV	A*VC960403BNA*	17,800	13,100	15.00	12.50	615	7515790
	CHPF3636B6C*+TXV	A*EC960402BNA*	17,800	13,100	15.00	12.50	575	7515786
	CHPF3636B6C*+TXV	G*EC960402BNA*	17,800	13,100	15.00	12.50	575	7515797
	CHPF3636B6C*+TXV	G*VC80604B*B*	17,800	13,100	15.00	12.50	620	7515800
	CHPF3636B6C*+TXV	A*VC80604B*B*	17,800	13,100	15.00	12.50	620	7515789
	CHPF3636B6C*+TXV	G*EC960803BNA*	17,800	13,100	15.00	12.50	540	7515799
	CHPF3636B6C*+TXV	G*VM970804CNA*	17,800	13,100	15.00	12.50	620	7515805
	CHPF3636B6C*+TXV	G*VC960403BNA*	17,800	13,100	15.00	12.50	615	7515801
	CHPF3636B6C*+TXV	G*VC960803BNA*	17,800	13,100	15.00	12.50	620	7515803
	CHPF3636B6C*+TXV	G*EC960603BNA*	17,800	13,100	15.00	12.50	500	7515798
	CHPF3636B6C*+TXV	A*EC960302BNA*	17,800	13,100	15.00	12.50	575	7515785
	CHPF3636B6C*+TXV	G*EC960302BNA*	17,800	13,100	15.00	12.50	575	7515796
	CHPF3636B6C*+TXV	G*VM970603BNA*	17,800	13,100	15.00	12.50	625	7515804
	CHPF3636B6C*+TXV	G*VC960603BNA*	17,800	13,100	15.00	12.50	625	7515802
	CHPF3636B6C*+TXV	A*VC960603BNA*	17,800	13,100	15.00	12.50	625	7515791
	CHPF3636B6C*+TXV	A*EC960803BNA*	17,800	13,100	15.00	12.50	540	7515788
	CHPF3636B6C*+TXV	A*EC960603BNA*	17,800	13,100	15.00	12.50	500	7515787
	CHPF3636B6C*+TXV	A*VC960803BNA*	17,800	13,100	15.00	12.50	620	7515792
	CHPF3636B6C*+TXV	G*E80603B*B*	17,800	13,100	15.00	12.50	600	7515795
	CSCF3036N6D*+EEP+TXV		17,600	13,000	14.00	12.20	550	7515806
	CSCF3036N6D*+TXV	G*VC80604B*B*	17,800	13,100	15.00	12.50	620	7515813
	CSCF3036N6D*+TXV	A*VC960403BNA*	17,800	13,100	15.00	12.50	615	7515808
	CSCF3036N6D*+TXV	G*VC960603BNA*	17,800	13,100	15.00	12.50	625	7515815
	CSCF3036N6D*+TXV	A*VC960603BNA*	17,800	13,100	15.00	12.50	625	7515809
	CSCF3036N6D*+TXV	A*VM970804CNA*	17,800	13,100	15.00	12.50	620	7515812
	CSCF3036N6D*+TXV	G*VC960803BNA*	17,800	13,100	15.00	12.50	620	7515816
	CSCF3036N6D*+TXV	A*VM970603BNA*	17,800	13,100	15.00	12.50	625	7515811
	CSCF3036N6D*+TXV	A*VC80604B*B*	17,800	13,100	15.00	12.50	620	7515807
	CSCF3036N6D*+TXV	G*VM970804CNA*	17,800	13,100	15.00	12.50	620	7515818
	CSCF3036N6D*+TXV	G*VC960403BNA*	17,800	13,100	15.00	12.50	615	7515814
	CSCF3036N6D*+TXV	A*VC960803BNA*	17,800	13,100	15.00	12.50	620	7515810
	CSCF3036N6D*+TXV	G*VM970603BNA*	17,800	13,100	15.00	12.50	625	7515817
	CSCF3642N6D*+TXV	A*EC960803BNA*	17,800	13,100	15.00	12.50	540	7515822
	CSCF3642N6D*+TXV	A*EC960603BNA*	17,800	13,100	15.00	12.50	500	7515821
	CSCF3642N6D*+TXV	G*EC960302BNA*	17,800	13,100	15.00	12.50	575	7515823
CSCF3642N6D*+TXV	G*EC960803BNA*	17,800	13,100	15.00	12.50	540	7515826	
CSCF3642N6D*+TXV	A*EC960302BNA*	17,800	13,100	15.00	12.50	575	7515819	
CSCF3642N6D*+TXV	G*EC960402BNA*	17,800	13,100	15.00	12.50	575	7515824	
CSCF3642N6D*+TXV	A*EC960402BNA*	17,800	13,100	15.00	12.50	575	7515820	
CSCF3642N6D*+TXV	G*EC960603BNA*	17,800	13,100	15.00	12.50	500	7515825	

¹ BTU/h

² Seasonal Energy Efficiency Ratio; Certified per AHRI 210/240 @ 80°F/ 67°F/ 95°F

³ Energy Efficiency Ratio @ 80°F/ 67°F/ 95°F

NOTES

- Always check the S&R plate for electrical data on the unit being installed.
- When matching the outdoor unit to the indoor unit, use the piston supplied with the outdoor unit or that specified on the piston kit chart supplied with the indoor unit.
- EEP - Order from Service Dept. Part No. B13707-38 or new Solid State Board B13707-35S. Part No. B13707-38 is not interchangeable with B13707-35S. The Goodman Gas Furnace contains the EEP cooling time delay

OUTDOOR UNIT	INDOOR UNITS		COOLING RATINGS				CFM	AHRI #
	COILS/AIR HANDLERS	FURNACES	TOTAL ¹	SENS. ¹	SEER ²	EER ³		
GSX14 0241K*	ASPT24B14A*		23,000	16,700	14.00	11.50	810	7515827
	ASPT30C14A*		23,600	17,100	14.50	12.00	845	7515828
	AVPTC24B14A*		23,000	16,700	14.00	11.50	795	7515829
	AVPTC30C14A*		23,600	17,100	14.50	12.00	780	7515830
	AWUF31XX16A*		23,000	16,700	14.50	11.50	800	7515831
	AWUF32XX16A*		23,000	16,700	14.50	11.50	800	7515832
	CA*F3636*6D*	A*EC960603BNA*	23,400	16,900	14.50	11.50	725	7515864
	CA*F3636*6D*	G*EC960402BNA*	23,400	16,900	14.50	11.50	775	7515877
	CA*F3636*6D*	A*VC960803BNA*	23,600	17,100	14.50	11.50	820	7515870
	CA*F3636*6D*	A*VM970804CNA*	23,600	17,100	14.50	11.50	810	7515874
	CA*F3636*6D*	A*VC80604B*B*	23,600	17,100	14.50	11.50	750	7515866
	CA*F3636*6D*	A*VC960804CNA*	23,600	17,100	14.50	11.50	810	7515871
	CA*F3636*6D*	G*VM970803BNA*	23,600	17,100	14.50	11.50	800	7515887
	CA*F3636*6D*	G*VC960403BNA*	23,600	17,100	14.50	11.50	805	7515882
	CA*F3636*6D*	A*VM970603BNA*	23,600	17,100	14.50	11.50	820	7515872
	CA*F3636*6D*	G*VC960603BNA*	23,600	17,100	14.50	11.50	820	7515883
	CA*F3636*6D*	G*VC960803BNA*	23,600	17,100	14.50	11.50	820	7515884
	CA*F3636*6D*	A*VC960403BNA*	23,600	17,100	14.50	11.50	805	7515868
	CA*F3636*6D*	G*VC960804CNA*	23,600	17,100	14.50	11.50	810	7515885
	CA*F3636*6D*	G*VM970804CNA*	23,600	17,100	14.50	11.50	810	7515888
	CA*F3636*6D*	G*EC960302BNA*	23,400	16,900	14.50	11.50	750	7515876
	CA*F3636*6D*	G*EC960803BNA*	23,400	16,900	14.50	11.50	750	7515879
	CA*F3636*6D*	G*VC80604B*B*	23,600	17,100	14.50	11.50	750	7515880
	CA*F3636*6D*	A*VM970803BNA*	23,600	17,100	14.50	11.50	800	7515873
	CA*F3636*6D*	A*EC960402BNA*	23,400	16,900	14.50	11.50	775	7515863
	CA*F3636*6D*	A*VC80805C*B*	23,600	17,100	14.50	11.50	730	7515867
	CA*F3636*6D*	G*E80603B*B*	23,600	17,100	14.50	11.50	725	7515875
	CA*F3636*6D*	G*VM970603BNA*	23,600	17,100	14.50	11.50	820	7515886
	CA*F3636*6D*	A*EC960803BNA*	23,400	16,900	14.50	11.50	750	7515865
	CA*F3636*6D*	G*VC80805C*B*	23,600	17,100	14.50	11.50	730	7515881
	CA*F3636*6D*	G*EC960603BNA*	23,400	16,900	14.50	11.50	725	7515878
	CA*F3636*6D*	A*EC960302BNA*	23,400	16,900	14.50	11.50	750	7515862
	CA*F3636*6D*	A*VC960603BNA*	23,600	17,100	14.50	11.50	820	7515869
	CA*F3636*6D*+EEP		23,600	17,100	14.00	11.50	725	7515833
	CA*F3636*6D*+EEP+TXV		23,600	17,100	14.00	11.50	725	7515834
	CA*F3636*6D*+MBVC1200**-1A*		23,600	17,100	14.50	12.00	725	7520285
	CA*F3636*6D*+TXV	A*EC960402BNA*	23,400	16,900	14.50	11.50	775	7515836
	CA*F3636*6D*+TXV	G*VC960603BNA*	23,600	17,100	14.50	11.50	820	7515856
	CA*F3636*6D*+TXV	G*VC80604B*B*	23,600	17,100	14.50	11.50	750	7515853
	CA*F3636*6D*+TXV	A*VC960603BNA*	23,600	17,100	14.50	11.50	820	7515842
	CA*F3636*6D*+TXV	A*VM970603BNA*	23,600	17,100	14.50	11.50	820	7515845
	CA*F3636*6D*+TXV	A*VC960804CNA*	23,600	17,100	14.50	11.50	810	7515844
	CA*F3636*6D*+TXV	A*VC960803BNA*	23,600	17,100	14.50	11.50	800	7515843
	CA*F3636*6D*+TXV	G*EC960302BNA*	23,400	16,900	14.50	11.50	750	7515849
	CA*F3636*6D*+TXV	G*VC80805C*B*	23,600	17,100	14.50	11.50	730	7515854
	CA*F3636*6D*+TXV	A*VC960403BNA*	23,600	17,100	14.50	11.50	805	7515841
	CA*F3636*6D*+TXV	G*VC960803BNA*	23,600	17,100	14.50	11.50	800	7515857
	CA*F3636*6D*+TXV	A*VC80604B*B*	23,600	17,100	14.50	11.50	750	7515839
CA*F3636*6D*+TXV	A*VM970804CNA*	23,600	17,100	14.50	11.50	810	7515847	
CA*F3636*6D*+TXV	A*EC960803BNA*	23,400	16,900	14.50	11.50	750	7515838	
CA*F3636*6D*+TXV	A*VC80805C*B*	23,600	17,100	14.50	11.50	730	7515840	
CA*F3636*6D*+TXV	G*EC960803BNA*	23,400	16,900	14.50	11.50	750	7515852	
CA*F3636*6D*+TXV	G*E80603B*B*	23,600	17,100	14.50	11.50	725	7515848	

See Notes on Page 32.

OUTDOOR UNIT	INDOOR UNITS		COOLING RATINGS				CFM	AHRI #
	COILS/AIR HANDLERS	FURNACES	TOTAL ¹	SENS. ¹	SEER ²	EER ³		
GSX14 0241K* (cont.)	CA*F3636*6D*+TXV	G*VC960804CNA*	23,600	17,100	14.50	11.50	810	7515858
	CA*F3636*6D*+TXV	A*VM970803BNA*	23,600	17,100	14.50	11.50	800	7515846
	CA*F3636*6D*+TXV	G*VM970603BNA*	23,600	17,100	14.50	11.50	820	7515859
	CA*F3636*6D*+TXV	G*EC960402BNA*	23,400	16,900	14.50	11.50	775	7515850
	CA*F3636*6D*+TXV	G*EC960603BNA*	23,400	16,900	14.50	11.50	725	7515851
	CA*F3636*6D*+TXV	A*EC960603BNA*	23,400	16,900	14.50	11.50	725	7515837
	CA*F3636*6D*+TXV	G*VM970803BNA*	23,600	17,100	14.50	11.50	800	7515860
	CA*F3636*6D*+TXV	G*VC960403BNA*	23,600	17,100	14.50	11.50	805	7515855
	CA*F3636*6D*+TXV	G*VM970804CNA*	23,600	17,100	14.50	11.50	810	7515861
	CA*F3636*6D*+TXV	A*EC960302BNA*	23,400	16,900	14.50	11.50	750	7515835
	CA*F3642*6D*+EEP		23,600	17,100	14.00	11.50	725	7515889
	CA*F3743*6D*+EEP		23,600	17,100	14.00	11.50	725	7515890
	CA*F3743*6D*+EEP+TXV		23,600	17,100	14.50	12.00	725	7515891
	CAPT3743*4A*	G*VC960603BNA*	23,400	16,900	14.50	11.50	820	7515915
	CAPT3743*4A*	A*VM970603BNA*	23,400	16,900	14.50	11.50	820	7515904
	CAPT3743*4A*	G*EC960402BNA*	23,400	16,900	14.50	11.50	775	7515909
	CAPT3743*4A*	G*VC960803BNA*	23,400	16,900	14.50	11.50	800	7515916
	CAPT3743*4A*	G*EC960302BNA*	23,400	16,900	14.50	11.50	750	7515908
	CAPT3743*4A*	A*VC80805C*B*	23,600	17,100	14.50	11.50	730	7515899
	CAPT3743*4A*	A*EC960803BNA*	23,400	16,900	14.50	11.50	750	7515897
	CAPT3743*4A*	G*VC80805C*B*	23,600	17,100	14.50	11.50	730	7515913
	CAPT3743*4A*	G*EC960803BNA*	23,400	16,900	14.50	11.50	750	7515911
	CAPT3743*4A*	A*EC960402BNA*	23,400	16,900	14.50	11.50	775	7515895
	CAPT3743*4A*	A*EC960603BNA*	23,400	16,900	14.50	11.50	725	7515896
	CAPT3743*4A*	G*VM970803BNA*	23,400	16,900	14.50	11.50	800	7515919
	CAPT3743*4A*	A*VM970803BNA*	23,400	16,900	14.50	11.50	800	7515905
	CAPT3743*4A*	G*VM970603BNA*	23,400	16,900	14.50	11.50	820	7515918
	CAPT3743*4A*	A*EC960302BNA*	23,400	16,900	14.50	11.50	750	7515894
	CAPT3743*4A*	G*EC960603BNA*	23,400	16,900	14.50	11.50	725	7515910
	CAPT3743*4A*	G*VC960804CNA*	23,600	17,100	14.50	11.50	810	7515917
	CAPT3743*4A*	A*VC960804CNA*	23,600	17,100	14.50	11.50	810	7515903
	CAPT3743*4A*	G*E80603B*B*	23,600	17,100	14.50	11.50	725	7515907
	CAPT3743*4A*	A*VM970804CNA*	23,600	17,100	14.50	11.50	810	7515906
	CAPT3743*4A*	A*VC960803BNA*	23,400	16,900	14.50	11.50	800	7515902
	CAPT3743*4A*	A*VC80604B*B*	23,600	17,100	14.50	11.50	750	7515898
	CAPT3743*4A*	G*VM970804CNA*	23,600	17,100	14.50	11.50	810	7515920
	CAPT3743*4A*	A*VC960403BNA*	23,400	16,900	14.50	11.50	805	7515900
	CAPT3743*4A*	G*VC80604B*B*	23,600	17,100	14.50	11.50	750	7515912
	CAPT3743*4A*	G*VC960403BNA*	23,400	16,900	14.50	11.50	805	7515914
	CAPT3743*4A*	A*VC960603BNA*	23,400	16,900	14.50	11.50	820	7515901
	CAPT3743*4A*+EEP		23,000	16,700	14.00	11.50	725	7515892
	CAPT3743*4A*+MBVC1200**-1A*		23,600	17,100	14.50	12.00	760	7515893
	CHPF3636B6C*	G*VM970603BNA*	23,600	17,100	14.50	11.50	820	7515964
	CHPF3636B6C*	G*EC960803BNA*	23,400	16,900	14.50	11.50	750	7515959
	CHPF3636B6C*	A*VC80604B*B*	23,600	17,100	14.50	11.50	750	7515949
	CHPF3636B6C*	A*VC960603BNA*	23,600	17,100	14.50	11.50	820	7515951
	CHPF3636B6C*	A*EC960803BNA*	23,400	16,900	14.50	11.50	750	7515948
	CHPF3636B6C*	A*EC960603BNA*	23,400	16,900	14.50	11.50	725	7515947
	CHPF3636B6C*	G*EC960402BNA*	23,400	16,900	14.50	11.50	775	7515957
	CHPF3636B6C*	A*VM970603BNA*	23,600	17,100	14.50	11.50	820	7515953
CHPF3636B6C*	A*VC960803BNA*	23,600	17,100	14.50	11.50	800	7515952	
CHPF3636B6C*	G*E80603B*B*	23,600	17,100	14.50	11.50	725	7515955	
CHPF3636B6C*	A*VM970803BNA*	23,600	17,100	14.50	11.50	800	7515954	

See Notes on Page 32.

OUTDOOR UNIT	INDOOR UNITS		COOLING RATINGS				CFM	AHRI #
	COILS/AIR HANDLERS	FURNACES	TOTAL ¹	SENS. ¹	SEER ²	EER ³		
GSX14 0241K* (cont.)	CHPF3636B6C*	G*VC960403BNA*	23,600	17,100	14.50	11.50	805	7515961
	CHPF3636B6C*	A*VC960403BNA*	23,600	17,100	14.50	11.50	805	7515950
	CHPF3636B6C*	A*EC960302BNA*	23,400	16,900	14.50	11.50	750	7515945
	CHPF3636B6C*	G*VM970803BNA*	23,600	17,100	14.50	11.50	800	7515965
	CHPF3636B6C*	G*EC960302BNA*	23,400	16,900	14.50	11.50	750	7515956
	CHPF3636B6C*	G*VC960803BNA*	23,600	17,100	14.50	11.50	800	7515963
	CHPF3636B6C*	G*EC960603BNA*	23,400	16,900	14.50	11.50	725	7515958
	CHPF3636B6C*	G*VC960603BNA*	23,600	17,100	14.50	11.50	820	7515962
	CHPF3636B6C*	A*EC960402BNA*	23,400	16,900	14.50	11.50	775	7515946
	CHPF3636B6C*	G*VC80604B*B*	23,600	17,100	14.50	11.50	750	7515960
	CHPF3636B6C*+EEP		23,600	17,100	14.00	11.50	725	7515921
	CHPF3636B6C*+EEP+TXV		23,600	17,100	14.50	11.50	725	7515922
	CHPF3636B6C*+MBVC1200**-1A*		23,600	17,100	14.50	12.00	725	7515923
	CHPF3636B6C*+TXV	G*VM970603BNA*	23,600	17,100	14.50	11.50	820	7515943
	CHPF3636B6C*+TXV	A*VC80604B*B*	23,600	17,100	14.50	11.50	750	7515928
	CHPF3636B6C*+TXV	G*EC960803BNA*	23,400	16,900	14.50	11.50	750	7515938
	CHPF3636B6C*+TXV	G*VM970803BNA*	23,600	17,100	14.50	11.50	800	7515944
	CHPF3636B6C*+TXV	G*VC960603BNA*	23,600	17,100	14.50	11.50	820	7515941
	CHPF3636B6C*+TXV	G*VC80604B*B*	23,600	17,100	14.50	11.50	750	7515939
	CHPF3636B6C*+TXV	A*VM970603BNA*	23,600	17,100	14.50	11.50	820	7515932
	CHPF3636B6C*+TXV	A*VC960803BNA*	23,600	17,100	14.50	11.50	800	7515931
	CHPF3636B6C*+TXV	G*VC960403BNA*	23,600	17,100	14.50	11.50	805	7515940
	CHPF3636B6C*+TXV	G*VC960803BNA*	23,600	17,100	14.50	11.50	800	7515942
	CHPF3636B6C*+TXV	A*EC960803BNA*	23,400	16,900	14.50	11.50	750	7515927
	CHPF3636B6C*+TXV	G*E80603B*B*	23,600	17,100	14.50	11.50	725	7515934
	CHPF3636B6C*+TXV	A*VC960403BNA*	23,600	17,100	14.50	11.50	805	7515929
	CHPF3636B6C*+TXV	A*VC960603BNA*	23,600	17,100	14.50	11.50	820	7515930
	CHPF3636B6C*+TXV	A*EC960402BNA*	23,400	16,900	14.50	11.50	775	7515925
	CHPF3636B6C*+TXV	A*VM970803BNA*	23,600	17,100	14.50	11.50	800	7515933
	CHPF3636B6C*+TXV	G*EC960402BNA*	23,400	16,900	14.50	11.50	775	7515936
	CHPF3636B6C*+TXV	A*EC960603BNA*	23,400	16,900	14.50	11.50	725	7515926
	CHPF3636B6C*+TXV	G*EC960302BNA*	23,400	16,900	14.50	11.50	750	7515935
	CHPF3636B6C*+TXV	G*EC960603BNA*	23,400	16,900	14.50	11.50	725	7515937
	CHPF3636B6C*+TXV	A*EC960302BNA*	23,400	16,900	14.50	11.50	750	7515924
	CHPF3642C6C*	A*VC960804CNA*	23,600	17,100	14.50	11.50	810	7515975
	CHPF3642C6C*	G*VC960804CNA*	23,600	17,100	14.50	11.50	810	7515978
	CHPF3642C6C*	A*VM970804CNA*	23,600	17,100	14.50	11.50	810	7515976
	CHPF3642C6C*	A*VC80805C*B*	23,600	17,100	14.50	11.50	730	7515974
	CHPF3642C6C*	G*VC80805C*B*	23,600	17,100	14.50	11.50	730	7515977
	CHPF3642C6C*	G*VM970804CNA*	23,600	17,100	14.50	11.50	810	7515979
	CHPF3642C6C*+EEP		23,600	17,100	14.00	11.50	725	7515966
	CHPF3642C6C*+EEP+TXV		23,600	17,100	14.50	11.50	725	7515967
	CHPF3642C6C*+TXV	G*VC80805C*B*	23,600	17,100	14.50	11.50	730	7515971
	CHPF3642C6C*+TXV	G*VM970804CNA*	23,600	17,100	14.50	11.50	810	7515973
	CHPF3642C6C*+TXV	A*VC80805C*B*	23,600	17,100	14.50	11.50	730	7515968
	CHPF3642C6C*+TXV	G*VC960804CNA*	23,600	17,100	14.50	11.50	810	7515972
	CHPF3642C6C*+TXV	A*VM970804CNA*	23,600	17,100	14.50	11.50	810	7515970
	CHPF3642C6C*+TXV	A*VC960804CNA*	23,600	17,100	14.50	11.50	810	7515969
	CSCF3036N6D*	G*VM970803BNA*	23,600	17,100	14.50	11.50	800	7516032
	CSCF3036N6D*	A*VC80805C*B*	23,600	17,100	14.50	11.50	730	7516013
CSCF3036N6D*	A*EC960603BNA*	23,400	16,900	14.50	11.50	725	7516010	
CSCF3036N6D*	A*EC960302BNA*	23,400	16,900	14.50	11.50	750	7516008	
CSCF3036N6D*	G*EC960603BNA*	23,400	16,900	14.50	11.50	725	7516023	

See Notes on Page 32.

OUTDOOR UNIT	INDOOR UNITS		COOLING RATINGS				CFM	AHRI #
	COILS/AIR HANDLERS	FURNACES	TOTAL ¹	SENS. ¹	SEER ²	EER ³		
GSX14 0241K* (cont.)	CSCF3036N6D*	G*VC960803BNA*	23,600	17,100	14.50	11.50	800	7516029
	CSCF3036N6D*	A*VC960804CNA*	23,600	17,100	14.50	11.50	810	7516017
	CSCF3036N6D*	G*VC960804CNA*	23,600	17,100	14.50	11.50	810	7516030
	CSCF3036N6D*	G*VC80805C*B*	23,600	17,100	14.50	11.50	730	7516026
	CSCF3036N6D*	A*VM970803BNA*	23,600	17,100	14.50	11.50	800	7516019
	CSCF3036N6D*	A*VC960603BNA*	23,600	17,100	14.50	11.50	820	7516015
	CSCF3036N6D*	G*VC80604B*B*	23,600	17,100	14.50	11.50	750	7516025
	CSCF3036N6D*	A*VM970804CNA*	23,600	17,100	14.50	11.50	810	7516020
	CSCF3036N6D*	G*VM970804CNA*	23,600	17,100	14.50	11.50	810	7516033
	CSCF3036N6D*	A*VM970603BNA*	23,600	17,100	14.50	11.50	820	7516018
	CSCF3036N6D*	A*VC960803BNA*	23,600	17,100	14.50	11.50	800	7516016
	CSCF3036N6D*	A*EC960402BNA*	23,400	16,900	14.50	11.50	775	7516009
	CSCF3036N6D*	G*VM970603BNA*	23,600	17,100	14.50	11.50	820	7516031
	CSCF3036N6D*	G*EC960803BNA*	23,400	16,900	14.50	11.50	750	7516024
	CSCF3036N6D*	G*EC960402BNA*	23,400	16,900	14.50	11.50	775	7516022
	CSCF3036N6D*	G*VC960403BNA*	23,600	17,100	14.50	11.50	805	7516027
	CSCF3036N6D*	G*VC960603BNA*	23,600	17,100	14.50	11.50	820	7516028
	CSCF3036N6D*	G*EC960302BNA*	23,400	16,900	14.50	11.50	750	7516021
	CSCF3036N6D*	A*VC80604B*B*	23,600	17,100	14.50	11.50	750	7516012
	CSCF3036N6D*	A*VC960403BNA*	23,600	17,100	14.50	11.50	805	7516014
	CSCF3036N6D*	A*EC960803BNA*	23,400	16,900	14.50	11.50	750	7516011
	CSCF3036N6D*+EEP		23,600	17,100	14.00	11.50	800	7515980
	CSCF3036N6D*+EEP+TXV		23,600	17,100	14.00	11.50	800	7515981
	CSCF3036N6D*+TXV	G*VC960603BNA*	23,600	17,100	14.50	11.50	820	7516002
	CSCF3036N6D*+TXV	G*VC80805C*B*	23,600	17,100	14.50	11.50	730	7516000
	CSCF3036N6D*+TXV	A*VM970803BNA*	23,600	17,100	14.50	11.50	800	7515993
	CSCF3036N6D*+TXV	A*VC80805C*B*	23,600	17,100	14.50	11.50	730	7515987
	CSCF3036N6D*+TXV	A*EC960603BNA*	23,400	16,900	14.50	11.50	725	7515984
	CSCF3036N6D*+TXV	A*VM970603BNA*	23,600	17,100	14.50	11.50	820	7515992
	CSCF3036N6D*+TXV	G*VC960403BNA*	23,600	17,100	14.50	11.50	805	7516001
	CSCF3036N6D*+TXV	A*VC80604B*B*	23,600	17,100	14.50	11.50	750	7515986
	CSCF3036N6D*+TXV	A*EC960803BNA*	23,400	16,900	14.50	11.50	750	7515985
	CSCF3036N6D*+TXV	A*VC960803BNA*	23,600	17,100	14.50	11.50	800	7515990
	CSCF3036N6D*+TXV	G*EC960603BNA*	23,400	16,900	14.50	11.50	725	7515997
	CSCF3036N6D*+TXV	G*EC960803BNA*	23,400	16,900	14.50	11.50	750	7515998
	CSCF3036N6D*+TXV	A*VC960603BNA*	23,600	17,100	14.50	11.50	820	7515989
	CSCF3036N6D*+TXV	G*VM970804CNA*	23,600	17,100	14.50	11.50	810	7516007
	CSCF3036N6D*+TXV	A*VC960804CNA*	23,600	17,100	14.50	11.50	810	7515991
	CSCF3036N6D*+TXV	G*VC960803BNA*	23,600	17,100	14.50	11.50	800	7516003
	CSCF3036N6D*+TXV	G*VM970803BNA*	23,600	17,100	14.50	11.50	800	7516006
	CSCF3036N6D*+TXV	A*VC960403BNA*	23,600	17,100	14.50	11.50	805	7515988
	CSCF3036N6D*+TXV	G*EC960402BNA*	23,400	16,900	14.50	11.50	775	7515996
	CSCF3036N6D*+TXV	A*VM970804CNA*	23,600	17,100	14.50	11.50	810	7515994
	CSCF3036N6D*+TXV	G*VM970603BNA*	23,600	17,100	14.50	11.50	820	7516005
	CSCF3036N6D*+TXV	A*EC960302BNA*	23,400	16,900	14.50	11.50	750	7515982
	CSCF3036N6D*+TXV	G*EC960302BNA*	23,400	16,900	14.50	11.50	750	7515995
	CSCF3036N6D*+TXV	G*VC80604B*B*	23,600	17,100	14.50	11.50	750	7515999
	CSCF3036N6D*+TXV	G*VC960804CNA*	23,600	17,100	14.50	11.50	810	7516004
	CSCF3036N6D*+TXV	A*EC960402BNA*	23,400	16,900	14.50	11.50	775	7515983
	CSCF3642N6D*+EEP		23,600	17,100	14.00	11.50	725	7516034
CSCF3642N6D*+EEP+TXV		23,600	17,100	14.00	11.50	725	7516035	

¹ BTU/h

² Seasonal Energy Efficiency Ratio; Certified per AHRI 210/240 @ 80°F/ 67°F/ 95°F

³ Energy Efficiency Ratio @ 80°F/ 67°F/ 95°F

NOTES

- Always check the S&R plate for electrical data on the unit being installed.
- When matching the outdoor unit to the indoor unit, use the piston supplied with the outdoor unit or that specified on the piston kit chart supplied with the indoor unit.
- EEP - Order from Service Dept. Part No. B13707-38 or new Solid State Board B13707-35S. Part No. B13707-38 is not interchangeable with B13707-35S. The Goodman Gas Furnace contains the EEP cooling time delay

OUTDOOR UNIT	INDOOR UNITS		COOLING RATINGS				CFM	AHRI #
	COILS/AIR HANDLERS	FURNACES	TOTAL ¹	SENS. ¹	SEER ²	EER ³		
GSX14 0251K*	ASPT24B14A*		23,000	16,500	14.00	12.20	810	7516036
	ASPT30C14A*		23,600	16,900	15.00	12.50	845	7516037
	AVPTC24B14A*		23,000	16,500	14.00	12.20	795	7516038
	AVPTC30C14A*		23,600	16,900	15.00	12.50	780	7516039
	AWUF31XX16A*		23,000	16,500	14.50	12.20	800	7516040
	AWUF32XX16A*		23,000	16,500	14.50	12.20	800	7516041
	CA*F3636*6D*	A*VC960603BNA*	23,600	16,900	15.00	12.50	820	7516079
	CA*F3636*6D*	A*EC960302BNA*	23,400	16,800	14.50	12.20	750	7516072
	CA*F3636*6D*	G*EC960402BNA*	23,400	16,800	14.50	12.20	775	7516087
	CA*F3636*6D*	A*EC960803BNA*	23,400	16,800	14.50	12.20	750	7516075
	CA*F3636*6D*	A*VC80604B*B*	23,600	16,900	15.00	12.50	750	7516076
	CA*F3636*6D*	G*E80603B*B*	23,600	16,900	15.00	12.50	725	7516085
	CA*F3636*6D*	A*EC960402BNA*	23,400	16,800	14.50	12.20	775	7516073
	CA*F3636*6D*	G*EC960302BNA*	23,400	16,800	14.50	12.20	750	7516086
	CA*F3636*6D*	G*VC960403BNA*	23,600	16,900	15.00	12.50	805	7516092
	CA*F3636*6D*	G*VM970803BNA*	23,600	16,900	15.00	12.50	800	7516097
	CA*F3636*6D*	A*EC960603BNA*	23,400	16,800	14.50	12.20	775	7516074
	CA*F3636*6D*	G*VM970603BNA*	23,600	16,900	15.00	12.50	820	7516096
	CA*F3636*6D*	G*EC960803BNA*	23,400	16,800	14.50	12.20	750	7516089
	CA*F3636*6D*	A*VC80805C*B*	23,600	16,900	15.00	12.50	725	7516077
	CA*F3636*6D*	G*VC960603BNA*	23,600	16,900	15.00	12.50	820	7516093
	CA*F3636*6D*	A*VM970803BNA*	23,600	16,900	15.00	12.50	800	7516083
	CA*F3636*6D*	G*VC960804CNA*	23,600	16,900	15.00	12.50	810	7516095
	CA*F3636*6D*	A*VC960804CNA*	23,600	16,900	15.00	12.50	810	7516081
	CA*F3636*6D*	G*VC960803BNA*	23,600	16,900	15.00	12.50	820	7516094
	CA*F3636*6D*	A*VC960403BNA*	23,600	16,900	15.00	12.50	805	7516078
	CA*F3636*6D*	A*VC960803BNA*	23,600	16,900	15.00	12.50	820	7516080
	CA*F3636*6D*	G*VC80805C*B*	23,600	16,900	15.00	12.50	725	7516091
	CA*F3636*6D*	A*VM970603BNA*	23,600	16,900	15.00	12.50	820	7516082
	CA*F3636*6D*	G*VC80604B*B*	23,600	16,900	15.00	12.50	750	7516090
	CA*F3636*6D*	A*VM970804CNA*	23,600	16,900	15.00	12.50	810	7516084
	CA*F3636*6D*	G*EC960603BNA*	23,400	16,800	14.50	12.20	775	7516088
	CA*F3636*6D*	G*VM970804CNA*	23,600	16,900	15.00	12.50	810	7516098
	CA*F3636*6D*+EEP		23,600	16,900	14.00	12.20	725	7516042
	CA*F3636*6D*+EEP+TXV		23,600	16,900	14.00	12.20	725	7516043
	CA*F3636*6D*+MBVC1200**-1A*		23,600	16,900	15.00	12.50	775	7516044
	CA*F3636*6D*+TXV	G*VM970804CNA*	23,600	16,900	15.00	12.50	810	7516071
	CA*F3636*6D*+TXV	A*VM970803BNA*	23,600	16,900	15.00	12.50	800	7516056
	CA*F3636*6D*+TXV	A*VM970804CNA*	23,600	16,900	15.00	12.50	810	7516057
	CA*F3636*6D*+TXV	A*VC960603BNA*	23,600	16,900	15.00	12.50	820	7516052
	CA*F3636*6D*+TXV	A*EC960402BNA*	23,400	16,800	15.00	12.50	775	7516046
	CA*F3636*6D*+TXV	G*EC960302BNA*	23,400	16,800	15.00	12.50	750	7516059
CA*F3636*6D*+TXV	G*VC960803BNA*	23,600	16,900	15.00	12.50	800	7516067	
CA*F3636*6D*+TXV	A*VM970603BNA*	23,600	16,900	15.00	12.50	820	7516055	
CA*F3636*6D*+TXV	G*E80603B*B*	23,600	16,900	15.00	12.50	725	7516058	
CA*F3636*6D*+TXV	A*VC960804CNA*	23,600	16,900	15.00	12.50	810	7516054	
CA*F3636*6D*+TXV	G*VC960804CNA*	23,600	16,900	15.00	12.50	810	7516068	
CA*F3636*6D*+TXV	G*VC80805C*B*	23,600	16,900	15.00	12.50	725	7516064	
CA*F3636*6D*+TXV	G*VM970603BNA*	23,600	16,900	15.00	12.50	820	7516069	
CA*F3636*6D*+TXV	G*VC960403BNA*	23,600	16,900	15.00	12.50	805	7516065	
CA*F3636*6D*+TXV	A*EC960603BNA*	23,400	16,800	15.00	12.50	775	7516047	
CA*F3636*6D*+TXV	G*EC960402BNA*	23,400	16,800	15.00	12.50	775	7516060	
CA*F3636*6D*+TXV	A*VC80805C*B*	23,600	16,900	15.00	12.50	725	7516050	

See Notes on Page 36.

OUTDOOR UNIT	INDOOR UNITS		COOLING RATINGS				CFM	AHRI #
	COILS/AIR HANDLERS	FURNACES	TOTAL ¹	SENS. ¹	SEER ²	EER ³		
GSX14 0251K* (cont.)	CA*F3636*6D*+TXV	A*EC960803BNA*	23,400	16,800	15.00	12.50	750	7516048
	CA*F3636*6D*+TXV	G*VC80604B*B*	23,600	16,900	15.00	12.50	750	7516063
	CA*F3636*6D*+TXV	A*VC960403BNA*	23,600	16,900	15.00	12.50	805	7516051
	CA*F3636*6D*+TXV	A*VC80604B*B*	23,600	16,900	15.00	12.50	750	7516049
	CA*F3636*6D*+TXV	A*EC960302BNA*	23,400	16,800	15.00	12.50	750	7516045
	CA*F3636*6D*+TXV	G*EC960603BNA*	23,400	16,800	15.00	12.50	775	7516061
	CA*F3636*6D*+TXV	A*VC960803BNA*	23,600	16,900	15.00	12.50	800	7516053
	CA*F3636*6D*+TXV	G*EC960803BNA*	23,400	16,800	15.00	12.50	750	7516062
	CA*F3636*6D*+TXV	G*VC960603BNA*	23,600	16,900	15.00	12.50	820	7516066
	CA*F3636*6D*+TXV	G*VM970803BNA*	23,600	16,900	15.00	12.50	800	7516070
	CA*F3743*6D*+EEP		23,800	17,000	14.00	12.20	725	7516099
	CA*F3743*6D*+EEP+TXV		23,800	17,000	14.50	12.20	725	7516100
	CAPT3743*4A*	A*VM970603BNA*	23,400	16,800	15.00	12.50	820	7516113
	CAPT3743*4A*	G*VC960603BNA*	23,400	16,800	15.00	12.50	820	7516124
	CAPT3743*4A*	A*EC960402BNA*	23,400	16,800	14.50	12.20	775	7516104
	CAPT3743*4A*	G*VC80604B*B*	23,600	16,900	15.00	12.50	750	7516121
	CAPT3743*4A*	G*EC960603BNA*	23,400	16,800	14.50	12.20	725	7516119
	CAPT3743*4A*	A*VC960403BNA*	23,400	16,800	15.00	12.50	805	7516109
	CAPT3743*4A*	G*VM970804CNA*	23,600	16,900	15.00	12.50	810	7516129
	CAPT3743*4A*	A*EC960302BNA*	23,400	16,800	14.50	12.20	750	7516103
	CAPT3743*4A*	G*VM970603BNA*	23,400	16,800	15.00	12.50	820	7516127
	CAPT3743*4A*	G*EC960803BNA*	23,400	16,800	14.50	12.20	750	7516120
	CAPT3743*4A*	G*EC960302BNA*	23,400	16,800	14.50	12.20	750	7516117
	CAPT3743*4A*	A*VM970803BNA*	23,400	16,800	15.00	12.50	800	7516114
	CAPT3743*4A*	G*EC960402BNA*	23,400	16,800	14.50	12.20	775	7516118
	CAPT3743*4A*	A*VC80805C*B*	23,600	16,900	15.00	12.50	725	7516108
	CAPT3743*4A*	G*E80603B*B*	23,600	16,900	15.00	12.50	725	7516116
	CAPT3743*4A*	A*EC960603BNA*	23,400	16,800	14.50	12.20	725	7516105
	CAPT3743*4A*	A*EC960803BNA*	23,400	16,800	14.50	12.20	750	7516106
	CAPT3743*4A*	G*VC960804CNA*	23,600	16,900	15.00	12.50	810	7516126
	CAPT3743*4A*	G*VC80805C*B*	23,600	16,900	15.00	12.50	725	7516122
	CAPT3743*4A*	A*VC960603BNA*	23,400	16,800	15.00	12.50	820	7516110
	CAPT3743*4A*	G*VC960403BNA*	23,400	16,800	15.00	12.50	805	7516123
	CAPT3743*4A*	A*VC80604B*B*	23,600	16,900	15.00	12.50	750	7516107
	CAPT3743*4A*	A*VC960804CNA*	23,600	16,900	15.00	12.50	810	7516112
	CAPT3743*4A*	G*VM970803BNA*	23,400	16,800	15.00	12.50	800	7516128
	CAPT3743*4A*	A*VC960803BNA*	23,400	16,800	15.00	12.50	800	7516111
	CAPT3743*4A*	A*VM970804CNA*	23,600	16,900	15.00	12.50	810	7516115
	CAPT3743*4A*	G*VC960803BNA*	23,400	16,800	15.00	12.50	800	7516125
	CAPT3743*4A*+EEP		23,600	16,900	14.00	12.20	725	7516101
	CAPT3743*4A*+MBVC1200**-1A*		23,600	16,900	14.50	12.20	775	7516102
	CHPF3636B6C*	G*VC960403BNA*	23,600	16,900	15.00	12.50	805	7516170
	CHPF3636B6C*	G*VM970603BNA*	23,600	16,900	15.00	12.50	820	7516173
	CHPF3636B6C*	G*E80603B*B*	23,600	16,900	15.00	12.50	725	7516164
	CHPF3636B6C*	A*EC960603BNA*	23,400	16,800	14.50	12.20	725	7516156
	CHPF3636B6C*	A*VC80604B*B*	23,600	16,900	15.00	12.50	750	7516158
	CHPF3636B6C*	G*VC960803BNA*	23,600	16,900	15.00	12.50	800	7516172
	CHPF3636B6C*	G*EC960402BNA*	23,400	16,800	14.50	12.20	775	7516166
CHPF3636B6C*	G*VC80604B*B*	23,600	16,900	15.00	12.50	750	7516169	
CHPF3636B6C*	G*EC960603BNA*	23,400	16,800	14.50	12.20	725	7516167	
CHPF3636B6C*	G*EC960803BNA*	23,400	16,800	14.50	12.20	750	7516168	
CHPF3636B6C*	A*EC960402BNA*	23,400	16,800	14.50	12.20	775	7516155	
CHPF3636B6C*	A*VC960403BNA*	23,600	16,900	15.00	12.50	805	7516159	

See Notes on Page 36.

OUTDOOR UNIT	INDOOR UNITS		COOLING RATINGS				CFM	AHRI #
	COILS/AIR HANDLERS	FURNACES	TOTAL ¹	SENS. ¹	SEER ²	EER ³		
GSX14 0251K* (cont.)	CHPF3636B6C*	G*VM970803BNA*	23,600	16,900	15.00	12.50	800	7516174
	CHPF3636B6C*	A*VC960803BNA*	23,600	16,900	15.00	12.50	800	7516161
	CHPF3636B6C*	A*EC960302BNA*	23,400	16,800	14.50	12.20	750	7516154
	CHPF3636B6C*	G*VC960603BNA*	23,600	16,900	15.00	12.50	820	7516171
	CHPF3636B6C*	A*VC960603BNA*	23,600	16,900	15.00	12.50	820	7516160
	CHPF3636B6C*	G*EC960302BNA*	23,400	16,800	14.50	12.20	750	7516165
	CHPF3636B6C*	A*VM970603BNA*	23,600	16,900	15.00	12.50	820	7516162
	CHPF3636B6C*	A*VM970803BNA*	23,600	16,900	15.00	12.50	800	7516163
	CHPF3636B6C*	A*EC960803BNA*	23,400	16,800	14.50	12.20	750	7516157
	CHPF3636B6C*+EEP		23,600	16,900	14.00	12.20	725	7516130
	CHPF3636B6C*+EEP+TXV		23,600	16,900	14.50	12.20	725	7516131
	CHPF3636B6C*+MBVC1200**-1A*		23,600	16,900	15.00	12.50	775	7516132
	CHPF3636B6C*+TXV	G*VC960403BNA*	23,600	16,900	15.00	12.50	805	7516149
	CHPF3636B6C*+TXV	A*VC960803BNA*	23,600	16,900	15.00	12.50	800	7516140
	CHPF3636B6C*+TXV	G*VC960803BNA*	23,600	16,900	15.00	12.50	800	7516151
	CHPF3636B6C*+TXV	G*VC960603BNA*	23,600	16,900	15.00	12.50	820	7516150
	CHPF3636B6C*+TXV	A*EC960603BNA*	23,400	16,800	14.50	12.20	725	7516135
	CHPF3636B6C*+TXV	A*VC960603BNA*	23,600	16,900	15.00	12.50	820	7516139
	CHPF3636B6C*+TXV	A*EC960302BNA*	23,400	16,800	14.50	12.20	750	7516133
	CHPF3636B6C*+TXV	A*EC960803BNA*	23,400	16,800	14.50	12.20	750	7516136
	CHPF3636B6C*+TXV	A*VM970803BNA*	23,600	16,900	15.00	12.50	800	7516142
	CHPF3636B6C*+TXV	G*EC960402BNA*	23,400	16,800	14.50	12.20	775	7516145
	CHPF3636B6C*+TXV	A*EC960402BNA*	23,400	16,800	14.50	12.20	775	7516134
	CHPF3636B6C*+TXV	A*VC960403BNA*	23,600	16,900	15.00	12.50	805	7516138
	CHPF3636B6C*+TXV	G*EC960603BNA*	23,400	16,800	14.50	12.20	725	7516146
	CHPF3636B6C*+TXV	G*VM970803BNA*	23,600	16,900	15.00	12.50	800	7516153
	CHPF3636B6C*+TXV	G*EC960803BNA*	23,400	16,800	14.50	12.20	750	7516147
	CHPF3636B6C*+TXV	G*VC80604B*B*	23,600	16,900	15.00	12.50	750	7516148
	CHPF3636B6C*+TXV	G*EC960302BNA*	23,400	16,800	14.50	12.20	750	7516144
	CHPF3636B6C*+TXV	G*E80603B*B*	23,600	16,900	15.00	12.50	725	7516143
	CHPF3636B6C*+TXV	A*VC80604B*B*	23,600	16,900	15.00	12.50	750	7516137
	CHPF3636B6C*+TXV	G*VM970603BNA*	23,600	16,900	15.00	12.50	820	7516152
	CHPF3636B6C*+TXV	A*VM970603BNA*	23,600	16,900	15.00	12.50	820	7516141
	CHPF3642C6C*	G*VC960804CNA*	23,600	16,900	15.00	12.50	810	7516185
	CHPF3642C6C*	G*VC80805C*B*	23,600	16,900	15.00	12.50	725	7516184
	CHPF3642C6C*	A*VC80805C*B*	23,600	16,900	15.00	12.50	725	7516181
	CHPF3642C6C*	G*VM970804CNA*	23,600	16,900	15.00	12.50	810	7516186
	CHPF3642C6C*	A*VC960804CNA*	23,600	16,900	15.00	12.50	810	7516182
	CHPF3642C6C*	A*VM970804CNA*	23,600	16,900	15.00	12.50	810	7516183
	CHPF3642C6C*+TXV	A*VM970804CNA*	23,600	16,900	15.00	12.50	810	7516177
	CHPF3642C6C*+TXV	G*VC960804CNA*	23,600	16,900	15.00	12.50	810	7516179
	CHPF3642C6C*+TXV	A*VC80805C*B*	23,600	16,900	15.00	12.50	725	7516175
	CHPF3642C6C*+TXV	A*VC960804CNA*	23,600	16,900	15.00	12.50	810	7516176
	CHPF3642C6C*+TXV	G*VC80805C*B*	23,600	16,900	15.00	12.50	725	7516178
	CHPF3642C6C*+TXV	G*VM970804CNA*	23,600	16,900	15.00	12.50	810	7516180
	CSCF3036N6D*	A*VM970803BNA*	23,600	16,900	15.00	12.50	800	7516214
	CSCF3036N6D*	G*VM970803BNA*	23,600	16,900	15.00	12.50	800	7516223
	CSCF3036N6D*	A*VC960603BNA*	23,600	16,900	15.00	12.50	820	7516210
	CSCF3036N6D*	G*VM970603BNA*	23,600	16,900	15.00	12.50	820	7516222
	CSCF3036N6D*	A*VC80805C*B*	23,600	16,900	15.00	12.50	725	7516208
CSCF3036N6D*	A*VC80604B*B*	23,600	16,900	15.00	12.50	750	7516207	
CSCF3036N6D*	G*VC960804CNA*	23,600	16,900	15.00	12.50	810	7516221	
CSCF3036N6D*	G*VC80604B*B*	23,600	16,900	15.00	12.50	750	7516216	

See Notes on Page 36.

OUTDOOR UNIT	INDOOR UNITS		COOLING RATINGS				CFM	AHRI #
	COILS/AIR HANDLERS	FURNACES	TOTAL ¹	SENS. ¹	SEER ²	EER ³		
GSX14 0251K* (cont.)	CSCF3036N6D*	A*VC960804CNA*	23,600	16,900	15.00	12.50	810	7516212
	CSCF3036N6D*	G*VC960803BNA*	23,600	16,900	15.00	12.50	800	7516220
	CSCF3036N6D*	G*VM970804CNA*	23,600	16,900	15.00	12.50	810	7516224
	CSCF3036N6D*	A*VM970603BNA*	23,600	16,900	15.00	12.50	820	7516213
	CSCF3036N6D*	A*VM970804CNA*	23,600	16,900	15.00	12.50	810	7516215
	CSCF3036N6D*	A*VC960403BNA*	23,600	16,900	15.00	12.50	805	7516209
	CSCF3036N6D*	G*VC80805C*B*	23,600	16,900	15.00	12.50	725	7516217
	CSCF3036N6D*	A*VC960803BNA*	23,600	16,900	15.00	12.50	800	7516211
	CSCF3036N6D*	G*VC960403BNA*	23,600	16,900	15.00	12.50	805	7516218
	CSCF3036N6D*	G*VC960603BNA*	23,600	16,900	15.00	12.50	820	7516219
	CSCF3036N6D*+EEP		23,200	16,600	14.00	12.20	800	7516187
	CSCF3036N6D*+EEP+TXV		23,200	16,600	14.00	12.20	800	7516188
	CSCF3036N6D*+TXV	G*VC80805C*B*	23,600	16,900	15.00	12.50	725	7516199
	CSCF3036N6D*+TXV	G*VC960603BNA*	23,600	16,900	15.00	12.50	820	7516201
	CSCF3036N6D*+TXV	G*VC960803BNA*	23,600	16,900	15.00	12.50	800	7516202
	CSCF3036N6D*+TXV	A*VM970803BNA*	23,600	16,900	15.00	12.50	800	7516196
	CSCF3036N6D*+TXV	A*VC80805C*B*	23,600	16,900	15.00	12.50	725	7516190
	CSCF3036N6D*+TXV	G*VM970804CNA*	23,600	16,900	15.00	12.50	810	7516206
	CSCF3036N6D*+TXV	G*VM970603BNA*	23,600	16,900	15.00	12.50	820	7516204
	CSCF3036N6D*+TXV	A*VM970603BNA*	23,600	16,900	15.00	12.50	820	7516195
	CSCF3036N6D*+TXV	G*VC960804CNA*	23,600	16,900	15.00	12.50	810	7516203
	CSCF3036N6D*+TXV	G*VC960403BNA*	23,600	16,900	15.00	12.50	805	7516200
	CSCF3036N6D*+TXV	A*VC960603BNA*	23,600	16,900	15.00	12.50	820	7516192
	CSCF3036N6D*+TXV	G*VM970803BNA*	23,600	16,900	15.00	12.50	800	7516205
	CSCF3036N6D*+TXV	A*VC960804CNA*	23,600	16,900	15.00	12.50	810	7516194
	CSCF3036N6D*+TXV	A*VM970804CNA*	23,600	16,900	15.00	12.50	810	7516197
	CSCF3036N6D*+TXV	A*VC960403BNA*	23,600	16,900	15.00	12.50	805	7516191
	CSCF3036N6D*+TXV	A*VC80604B*B*	23,600	16,900	15.00	12.50	750	7516189
	CSCF3036N6D*+TXV	A*VC960803BNA*	23,600	16,900	15.00	12.50	800	7516193
	CSCF3036N6D*+TXV	G*VC80604B*B*	23,600	16,900	15.00	12.50	750	7516198
	CSCF3642N6D*	G*EC960402BNA*	23,400	16,800	14.50	12.20	775	7516238
	CSCF3642N6D*	G*EC960302BNA*	23,400	16,800	14.50	12.20	750	7516237
	CSCF3642N6D*	A*EC960803BNA*	23,400	16,800	14.50	12.20	750	7516236
	CSCF3642N6D*	G*EC960803BNA*	23,400	16,800	14.50	12.20	750	7516240
	CSCF3642N6D*	A*EC960302BNA*	23,400	16,800	14.50	12.20	750	7516233
	CSCF3642N6D*	A*EC960603BNA*	23,400	16,800	14.50	12.20	725	7516235
	CSCF3642N6D*	G*EC960603BNA*	23,400	16,800	14.50	12.20	725	7516239
	CSCF3642N6D*	A*EC960402BNA*	23,400	16,800	14.50	12.20	775	7516234
	CSCF3642N6D*+TXV	G*EC960603BNA*	23,400	16,800	14.50	12.20	725	7516231
	CSCF3642N6D*+TXV	A*EC960302BNA*	23,400	16,800	14.50	12.20	750	7516225
CSCF3642N6D*+TXV	A*EC960402BNA*	23,400	16,800	14.50	12.20	775	7516226	
CSCF3642N6D*+TXV	G*EC960803BNA*	23,400	16,800	14.50	12.20	750	7516232	
CSCF3642N6D*+TXV	G*EC960302BNA*	23,400	16,800	14.50	12.20	750	7516229	
CSCF3642N6D*+TXV	A*EC960603BNA*	23,400	16,800	14.50	12.20	725	7516227	
CSCF3642N6D*+TXV	G*EC960402BNA*	23,400	16,800	14.50	12.20	775	7516230	
CSCF3642N6D*+TXV	A*EC960803BNA*	23,400	16,800	14.50	12.20	750	7516228	

¹ BTU/h

² Seasonal Energy Efficiency Ratio; Certified per AHRI 210/240 @ 80°F/ 67°F/ 95°F

³ Energy Efficiency Ratio @ 80°F/ 67°F/ 95°F

NOTES

- Always check the S&R plate for electrical data on the unit being installed.
- When matching the outdoor unit to the indoor unit, use the piston supplied with the outdoor unit or that specified on the piston kit chart supplied with the indoor unit.
- EEP - Order from Service Dept. Part No. B13707-38 or new Solid State Board B13707-35S. Part No. B13707-38 is not interchangeable with B13707-35S. The Goodman Gas Furnace contains the EEP cooling time delay

OUTDOOR UNIT	INDOOR UNITS		COOLING RATINGS				CFM	AHRI #
	COILS/AIR HANDLERS	FURNACES	TOTAL ¹	SENS. ¹	SEER ²	EER ³		
GSX14 0301K*	ASPT36C14A*		29,000	21,400	14.50	12.00	1,010	7516241
	AVPTC36C14A*		29,000	21,400	14.50	12.00	1,085	7516242
	AWUF31XX16A*		28,000	20,800	14.00	11.50	950	7516243
	AWUF31XX16A*+TXV		28,400	21,000	14.50	11.50	1,000	7516244
	AWUF32XX16A*		28,000	20,800	14.00	11.50	950	7516245
	AWUF32XX16A*+TXV		28,400	21,000	14.50	11.50	1,000	7516246
	AWUF37XX16B*		28,400	21,000	14.00	11.50	1,000	7516247
	AWUF37XX16B*+TXV		28,600	21,200	14.50	11.50	1,000	7516248
	CA*F3642*6D*	G*VM970804CNA*	28,600	21,200	14.50	11.50	1,000	7516288
	CA*F3642*6D*	A*VC960804CNA*	28,600	21,200	14.50	11.50	1,000	7516285
	CA*F3642*6D*	G*VC960804CNA*	28,600	21,200	14.50	11.50	1,000	7516287
	CA*F3642*6D*	A*VM970804CNA*	28,600	21,200	14.50	11.50	1,000	7516286
	CA*F3642*6D*+EEP		28,800	21,400	14.00	11.50	1,000	7516249
	CA*F3642*6D*+EEP+TXV		28,800	21,400	14.00	11.50	1,000	7516250
	CA*F3642*6D*+MBVC1200**-1A*		28,800	21,400	14.50	11.50	980	7519535
	CA*F3642*6D*+MBVC1200**-1A*+TXV		28,800	21,400	14.50	12.00	980	7516251
	CA*F3642*6D*+MBVC1600**-1A*		28,800	21,400	14.50	11.50	1,000	7516252
	CA*F3642*6D*+MBVC1600**-1A*+TXV		28,800	21,400	14.50	12.00	1,000	7516253
	CA*F3642*6D*+TXV	G*EC960402BNA*	28,200	21,000	14.50	11.50	925	7516272
	CA*F3642*6D*+TXV	G*VC960603BNA*	28,800	21,400	14.50	11.50	1,040	7516280
	CA*F3642*6D*+TXV	A*EC960402BNA*	28,200	21,000	14.50	11.50	925	7516255
	CA*F3642*6D*+TXV	G*EC960302BNA*	28,200	21,000	14.50	11.50	940	7516271
	CA*F3642*6D*+TXV	A*EC961004CNA*	28,600	21,200	14.50	11.50	1,025	7516258
	CA*F3642*6D*+TXV	G*E81005C*B*	28,800	21,400	14.50	11.50	1,080	7516270
	CA*F3642*6D*+TXV	A*VC80604B*B*	28,400	21,000	14.50	11.50	1,000	7516259
	CA*F3642*6D*+TXV	A*VC960804CNA*	28,600	21,200	14.50	11.50	1,000	7516265
	CA*F3642*6D*+TXV	A*VC960403BNA*	28,600	21,200	14.50	11.50	1,000	7516262
	CA*F3642*6D*+TXV	A*VC960803BNA*	28,600	21,200	14.50	11.50	975	7516264
	CA*F3642*6D*+TXV	G*VC960803BNA*	28,600	21,200	14.50	11.50	975	7516281
	CA*F3642*6D*+TXV	G*VM970603BNA*	28,600	21,200	14.50	11.50	1,040	7516283
	CA*F3642*6D*+TXV	G*VC81005C*B*	28,400	21,000	14.50	11.50	1,000	7516278
	CA*F3642*6D*+TXV	A*VC80805C*B*	28,400	21,000	14.50	11.50	990	7516260
	CA*F3642*6D*+TXV	G*E80603B*B*	28,800	21,400	14.50	11.50	1,050	7516268
	CA*F3642*6D*+TXV	A*EC960603BNA*	28,200	21,000	14.50	11.50	965	7516256
	CA*F3642*6D*+TXV	G*EC961004CNA*	28,600	21,200	14.50	11.50	1,025	7516275
	CA*F3642*6D*+TXV	A*VC81005C*B*	28,400	21,000	14.50	11.50	1,000	7516261
	CA*F3642*6D*+TXV	G*EC960603BNA*	28,200	21,000	14.50	11.50	965	7516273
	CA*F3642*6D*+TXV	G*E80805C*B*	28,800	21,400	14.50	11.50	1,060	7516269
	CA*F3642*6D*+TXV	A*EC960803BNA*	28,200	21,000	14.50	11.50	950	7516257
	CA*F3642*6D*+TXV	A*EC960302BNA*	28,200	21,000	14.50	11.50	940	7516254
	CA*F3642*6D*+TXV	G*VC80805C*B*	28,400	21,000	14.50	11.50	990	7516277
	CA*F3642*6D*+TXV	G*VM970804CNA*	28,600	21,200	14.50	11.50	1,000	7516284
CA*F3642*6D*+TXV	G*VC80604B*B*	28,400	21,000	14.50	11.50	1,000	7516276	
CA*F3642*6D*+TXV	G*EC960803BNA*	28,200	21,000	14.50	11.50	950	7516274	
CA*F3642*6D*+TXV	G*VC960403BNA*	28,600	21,200	14.50	11.50	1,000	7516279	
CA*F3642*6D*+TXV	A*VC960603BNA*	28,800	21,400	14.50	11.50	1,040	7516263	
CA*F3642*6D*+TXV	A*VM970603BNA*	28,600	21,200	14.50	11.50	1,040	7516266	
CA*F3642*6D*+TXV	G*VC960804CNA*	28,600	21,200	14.50	11.50	1,000	7516282	
CA*F3642*6D*+TXV	A*VM970804CNA*	28,600	21,200	14.50	11.50	1,000	7516267	
CA*F3743*6D*	G*VC960804CNA*	28,800	21,400	14.50	11.50	1,000	7516324	
CA*F3743*6D*	G*VM970804CNA*	28,600	21,200	14.50	11.50	1,000	7516325	
CA*F3743*6D*	A*VM970804CNA*	28,600	21,200	14.50	11.50	1,000	7516323	
CA*F3743*6D*	A*VC960804CNA*	28,800	21,400	14.50	11.50	1,000	7516322	

See Notes on Page 40.

OUTDOOR UNIT	INDOOR UNITS		COOLING RATINGS				CFM	AHRI #
	COILS/AIR HANDLERS	FURNACES	TOTAL ¹	SENS. ¹	SEER ²	EER ³		
GSX14 0301K* (cont.)	CA*F3743*6D*+EEP		28,800	21,400	14.00	11.50	1,000	7516289
	CA*F3743*6D*+EEP+TXV		28,800	21,400	14.00	11.50	1,000	7516290
	CA*F3743*6D*+TXV	A*EC960302BNA*	28,400	21,000	14.50	11.50	940	7516291
	CA*F3743*6D*+TXV	A*EC961004CNA*	28,800	21,400	14.50	11.50	1,025	7516295
	CA*F3743*6D*+TXV	A*EC960803BNA*	28,400	21,000	14.50	11.50	950	7516294
	CA*F3743*6D*+TXV	A*VC960603BNA*	28,800	21,400	14.50	11.50	1,040	7516300
	CA*F3743*6D*+TXV	G*EC960603BNA*	28,400	21,000	14.50	11.50	965	7516310
	CA*F3743*6D*+TXV	G*VC960403BNA*	28,800	21,400	14.50	11.50	1,000	7516316
	CA*F3743*6D*+TXV	G*EC960402BNA*	28,400	21,000	14.50	11.50	925	7516309
	CA*F3743*6D*+TXV	G*VC81005C*B*	28,600	21,200	14.50	11.50	1,000	7516315
	CA*F3743*6D*+TXV	A*VC960804CNA*	28,800	21,400	14.50	11.50	1,000	7516302
	CA*F3743*6D*+TXV	G*VM970804CNA*	28,600	21,200	14.50	11.50	1,000	7516321
	CA*F3743*6D*+TXV	G*E81005C*B*	28,800	21,400	14.50	11.50	1,080	7516307
	CA*F3743*6D*+TXV	G*EC960302BNA*	28,400	21,000	14.50	11.50	940	7516308
	CA*F3743*6D*+TXV	A*EC960603BNA*	28,400	21,000	14.50	11.50	965	7516293
	CA*F3743*6D*+TXV	A*VC960803BNA*	28,600	21,200	14.50	11.50	975	7516301
	CA*F3743*6D*+TXV	G*VC960803BNA*	28,600	21,200	14.50	11.50	975	7516318
	CA*F3743*6D*+TXV	A*VC80604B*B*	28,600	21,200	14.50	11.50	1,000	7516296
	CA*F3743*6D*+TXV	G*VC960804CNA*	28,800	21,400	14.50	11.50	1,000	7516319
	CA*F3743*6D*+TXV	G*EC960803BNA*	28,400	21,000	14.50	11.50	950	7516311
	CA*F3743*6D*+TXV	G*VC960603BNA*	28,800	21,400	14.50	11.50	1,040	7516317
	CA*F3743*6D*+TXV	A*VM970804CNA*	28,600	21,200	14.50	11.50	1,000	7516304
	CA*F3743*6D*+TXV	A*VC80805C*B*	28,600	21,200	14.50	11.50	990	7516297
	CA*F3743*6D*+TXV	G*E80603B*B*	28,800	21,400	14.50	12.00	1,050	7516305
	CA*F3743*6D*+TXV	G*EC961004CNA*	28,800	21,400	14.50	11.50	1,025	7516312
	CA*F3743*6D*+TXV	A*VM970603BNA*	28,600	21,200	14.50	11.50	1,040	7516303
	CA*F3743*6D*+TXV	G*VC80805C*B*	28,600	21,200	14.50	11.50	990	7516314
	CA*F3743*6D*+TXV	A*VC81005C*B*	28,600	21,200	14.50	11.50	1,000	7516298
	CA*F3743*6D*+TXV	A*VC960403BNA*	28,800	21,400	14.50	11.50	1,000	7516299
	CA*F3743*6D*+TXV	G*E80805C*B*	28,800	21,400	14.50	12.00	1,060	7516306
	CA*F3743*6D*+TXV	A*EC960402BNA*	28,400	21,000	14.50	11.50	925	7516292
	CA*F3743*6D*+TXV	G*VC80604B*B*	28,600	21,200	14.50	11.50	1,000	7516313
	CA*F3743*6D*+TXV	G*VM970603BNA*	28,600	21,200	14.50	11.50	1,040	7516320
	CAPT3743*4A*	A*VC81005C*B*	28,400	21,000	14.50	11.50	1,000	7516336
	CAPT3743*4A*	G*VC960603BNA*	28,600	21,200	14.50	11.50	1,040	7516355
	CAPT3743*4A*	A*VM970804CNA*	28,600	21,200	14.50	11.50	1,000	7516342
	CAPT3743*4A*	A*EC961004CNA*	28,600	21,200	14.50	11.50	1,025	7516333
	CAPT3743*4A*	A*VC960803BNA*	28,400	21,000	14.50	11.50	975	7516339
	CAPT3743*4A*	G*VM970603BNA*	28,600	21,200	14.50	11.50	1,040	7516358
	CAPT3743*4A*	A*EC960603BNA*	28,200	21,000	14.50	11.50	965	7516331
	CAPT3743*4A*	G*VC80604B*B*	28,400	21,000	14.50	11.50	1,000	7516351
	CAPT3743*4A*	G*EC961004CNA*	28,600	21,200	14.50	11.50	1,025	7516350
	CAPT3743*4A*	G*EC960603BNA*	28,200	21,000	14.50	11.50	965	7516348
	CAPT3743*4A*	G*VC960403BNA*	28,600	21,200	14.50	11.50	1,000	7516354
	CAPT3743*4A*	G*E81005C*B*	28,800	21,400	14.50	11.50	1,080	7516345
	CAPT3743*4A*	G*VM970804CNA*	28,600	21,200	14.50	11.50	1,000	7516359
	CAPT3743*4A*	A*VC80805C*B*	28,400	21,000	14.50	11.50	990	7516335
CAPT3743*4A*	G*EC960402BNA*	28,200	21,000	14.50	11.50	925	7516347	
CAPT3743*4A*	G*VC960803BNA*	28,400	21,000	14.50	11.50	975	7516356	
CAPT3743*4A*	A*EC960803BNA*	28,200	21,000	14.50	11.50	950	7516332	
CAPT3743*4A*	A*EC960402BNA*	28,200	21,000	14.50	11.50	925	7516330	
CAPT3743*4A*	A*VM970603BNA*	28,600	21,200	14.50	11.50	1,040	7516341	
CAPT3743*4A*	G*VC81005C*B*	28,400	21,000	14.50	11.50	1,000	7516353	

See Notes on Page 40.

OUTDOOR UNIT	INDOOR UNITS		COOLING RATINGS				CFM	AHRI #
	COILS/AIR HANDLERS	FURNACES	TOTAL ¹	SENS. ¹	SEER ²	EER ³		
	CAPT3743*4A*	G*EC960302BNA*	28,200	21,000	14.50	11.50	940	7516346
	CAPT3743*4A*	G*E80603B*B*	28,800	21,400	14.50	11.50	1,050	7516343
	CAPT3743*4A*	G*VC80805C*B*	28,400	21,000	14.50	11.50	990	7516352
	CAPT3743*4A*	A*EC960302BNA*	28,200	21,000	14.50	11.50	940	7516329
	CAPT3743*4A*	G*EC960803BNA*	28,200	21,000	14.50	11.50	950	7516349
	CAPT3743*4A*	G*VC960804CNA*	28,600	21,200	14.50	11.50	1,000	7516357
	CAPT3743*4A*	G*E80805C*B*	28,800	21,400	14.50	11.50	1,060	7516344
	CAPT3743*4A*	A*VC960804CNA*	28,600	21,200	14.50	11.50	1,000	7516340
	CAPT3743*4A*	A*VC960603BNA*	28,600	21,200	14.50	11.50	1,040	7516338
	CAPT3743*4A*	A*VC960403BNA*	28,600	21,200	14.50	11.50	1,000	7516337
	CAPT3743*4A*	A*VC80604B*B*	28,400	21,000	14.50	11.50	1,000	7516334
	CAPT3743*4A*+EEP		28,800	21,400	14.50	11.50	1,000	7516326
	CAPT3743*4A*+MBVC1200**-1A*		28,800	21,400	14.50	12.00	980	7516327
	CAPT3743*4A*+MBVC1600**-1A*		28,800	21,400	14.50	12.00	1,000	7516328
	CHPF3636B6C*+TXV	A*VC960803BNA*	28,600	21,200	14.50	11.50	975	7516362
	CHPF3636B6C*+TXV	G*VC960403BNA*	28,800	21,400	14.50	11.50	1,000	7516364
	CHPF3636B6C*+TXV	G*VC960803BNA*	28,600	21,200	14.50	11.50	975	7516366
	CHPF3636B6C*+TXV	A*VC960603BNA*	28,800	21,400	14.50	11.50	1,040	7516361
	CHPF3636B6C*+TXV	A*VM970603BNA*	28,600	21,200	14.50	11.50	1,040	7516363
	CHPF3636B6C*+TXV	G*VC960603BNA*	28,800	21,400	14.50	11.50	1,040	7516365
	CHPF3636B6C*+TXV	G*VM970603BNA*	28,600	21,200	14.50	11.50	1,040	7516367
	CHPF3636B6C*+TXV	A*VC960403BNA*	28,800	21,400	14.50	11.50	1,000	7516360
	CHPF3642C6C*	A*VC960804CNA*	28,800	21,400	14.50	11.50	1,000	7516396
	CHPF3642C6C*	G*VM970804CNA*	28,600	21,200	14.50	11.50	1,000	7516399
	CHPF3642C6C*	G*VC960804CNA*	28,800	21,400	14.50	11.50	1,000	7516398
	CHPF3642C6C*	A*VM970804CNA*	28,600	21,200	14.50	11.50	1,000	7516397
	CHPF3642C6C*+EEP		28,800	21,400	14.00	11.50	1,000	7516368
	CHPF3642C6C*+EEP+TXV		28,800	21,400	14.00	11.50	1,000	7516369
	CHPF3642C6C*+MBVC1200**-1A*		28,800	21,400	14.50	12.00	1,000	7519536
	CHPF3642C6C*+MBVC1200**-1A*+TXV		28,800	21,400	14.50	12.00	1,000	7516370
	CHPF3642C6C*+MBVC1600**-1A*		28,800	21,400	14.50	12.00	1,000	7516371
	CHPF3642C6C*+MBVC1600**-1A*+TXV		28,800	21,400	14.50	12.00	1,000	7516372
	CHPF3642C6C*+TXV	A*VC80604B*B*	28,600	21,200	14.50	11.50	1,000	7516378
	CHPF3642C6C*+TXV	A*VC81005C*B*	28,600	21,200	14.50	11.50	1,000	7516380
	CHPF3642C6C*+TXV	A*EC960603BNA*	28,400	21,000	14.50	11.50	965	7516375
	CHPF3642C6C*+TXV	A*EC961004CNA*	28,800	21,400	14.50	11.50	1,025	7516377
	CHPF3642C6C*+TXV	A*EC960302BNA*	28,400	21,000	14.50	11.50	940	7516373
	CHPF3642C6C*+TXV	G*VC81005C*B*	28,600	21,200	14.50	11.50	1,000	7516393
	CHPF3642C6C*+TXV	G*E80603B*B*	28,800	21,400	14.50	11.50	1,050	7516383
	CHPF3642C6C*+TXV	G*E80805C*B*	28,800	21,400	14.50	11.50	1,000	7516384
	CHPF3642C6C*+TXV	G*VM970804CNA*	28,600	21,200	14.50	11.50	1,000	7516395
	CHPF3642C6C*+TXV	G*EC960402BNA*	28,400	21,000	14.50	11.50	925	7516387
	CHPF3642C6C*+TXV	G*EC961004CNA*	28,800	21,400	14.50	11.50	1,025	7516390
	CHPF3642C6C*+TXV	G*EC960803BNA*	28,400	21,000	14.50	11.50	950	7516389
	CHPF3642C6C*+TXV	G*E81005C*B*	28,800	21,400	14.50	11.50	1,080	7516385
	CHPF3642C6C*+TXV	A*VM970804CNA*	28,600	21,200	14.50	11.50	1,000	7516382
	CHPF3642C6C*+TXV	A*VC960804CNA*	28,800	21,400	14.50	11.50	1,000	7516381
	CHPF3642C6C*+TXV	G*EC960603BNA*	28,400	21,000	14.50	11.50	965	7516388
	CHPF3642C6C*+TXV	A*EC960402BNA*	28,400	21,000	14.50	11.50	925	7516374
	CHPF3642C6C*+TXV	A*VC80805C*B*	28,600	21,200	14.50	11.50	990	7516379
	CHPF3642C6C*+TXV	G*VC80604B*B*	28,600	21,200	14.50	11.50	1,000	7516391
	CHPF3642C6C*+TXV	G*EC960302BNA*	28,400	21,000	14.50	11.50	940	7516386
	CHPF3642C6C*+TXV	G*VC80805C*B*	28,600	21,200	14.50	11.50	990	7516392

See Notes on Page 40.

OUTDOOR UNIT	INDOOR UNITS		COOLING RATINGS				CFM	AHRI #
	COILS/AIR HANDLERS	FURNACES	TOTAL ¹	SENS. ¹	SEER ²	EER ³		
GSX14 0301K* (cont.)	CHPF3642C6C*+TXV	G*VC960804CNA*	28,800	21,400	14.50	11.50	1,000	7516394
	CHPF3642C6C*+TXV	A*EC960803BNA*	28,400	21,000	14.50	11.50	950	7516376
	CHPF3743C6B*+EEP		28,800	21,400	14.00	11.50	1,000	7516400
	CHPF3743C6B*+EEP+TXV		28,800	21,400	14.00	11.50	1,000	7516401
	CHPF3743D6B*+EEP		28,800	21,400	14.00	11.50	1,000	7516402
	CHPF3743D6B*+EEP+TXV		28,800	21,400	14.00	11.50	1,000	7516403
	CSCF3642N6D*	A*VM970804CNA*	28,600	21,200	14.50	11.50	1,000	7516437
	CSCF3642N6D*	A*VC960804CNA*	28,800	21,400	14.50	11.50	1,000	7516436
	CSCF3642N6D*	G*VM970804CNA*	28,600	21,200	14.50	11.50	1,000	7516439
	CSCF3642N6D*	G*VC960804CNA*	28,800	21,400	14.50	11.50	1,000	7516438
	CSCF3642N6D*+EEP		28,600	21,200	14.00	11.50	1,000	7516404
	CSCF3642N6D*+EEP+TXV		28,600	21,200	14.00	11.50	1,000	7516405
	CSCF3642N6D*+TXV	G*EC960302BNA*	28,200	21,000	14.50	11.50	940	7516422
	CSCF3642N6D*+TXV	A*EC960603BNA*	28,200	21,000	14.50	11.50	965	7516408
	CSCF3642N6D*+TXV	A*VM970804CNA*	28,600	21,200	14.50	11.50	1,000	7516419
	CSCF3642N6D*+TXV	A*EC961004CNA*	28,400	21,000	14.50	11.50	1,025	7516410
	CSCF3642N6D*+TXV	A*VC80805C*B*	28,600	21,200	14.50	11.50	990	7516412
	CSCF3642N6D*+TXV	A*VC960803BNA*	28,600	21,200	14.50	11.50	975	7516416
	CSCF3642N6D*+TXV	G*VC81005C*B*	28,600	21,200	14.50	11.50	1,000	7516429
	CSCF3642N6D*+TXV	A*VC80604B*B*	28,600	21,200	14.50	11.50	1,000	7516411
	CSCF3642N6D*+TXV	G*EC960402BNA*	28,200	21,000	14.50	11.50	925	7516423
	CSCF3642N6D*+TXV	G*VC80805C*B*	28,600	21,200	14.50	11.50	990	7516428
	CSCF3642N6D*+TXV	G*E80603B*B*	28,800	21,400	14.50	11.50	1,050	7516420
	CSCF3642N6D*+TXV	G*VM970804CNA*	28,600	21,200	14.50	11.50	1,000	7516435
	CSCF3642N6D*+TXV	A*VC81005C*B*	28,600	21,200	14.50	11.50	1,000	7516413
	CSCF3642N6D*+TXV	G*EC960603BNA*	28,200	21,000	14.50	11.50	965	7516424
	CSCF3642N6D*+TXV	A*VC960403BNA*	28,800	21,400	14.50	11.50	1,000	7516414
	CSCF3642N6D*+TXV	A*EC960402BNA*	28,200	21,000	14.50	11.50	925	7516407
	CSCF3642N6D*+TXV	G*VC960804CNA*	28,800	21,400	14.50	11.50	1,000	7516433
	CSCF3642N6D*+TXV	A*VM970603BNA*	28,600	21,200	14.50	11.50	1,040	7516418
	CSCF3642N6D*+TXV	A*VC960804CNA*	28,800	21,400	14.50	11.50	1,000	7516417
	CSCF3642N6D*+TXV	G*VC80604B*B*	28,600	21,200	14.50	11.50	1,000	7516427
	CSCF3642N6D*+TXV	G*EC960803BNA*	28,400	21,000	14.50	11.50	950	7516425
	CSCF3642N6D*+TXV	G*EC961004CNA*	28,400	21,000	14.50	11.50	1,025	7516426
	CSCF3642N6D*+TXV	A*EC960302BNA*	28,200	21,000	14.50	11.50	940	7516406
	CSCF3642N6D*+TXV	G*VC960403BNA*	28,800	21,400	14.50	11.50	1,000	7516430
	CSCF3642N6D*+TXV	G*VC960803BNA*	28,600	21,200	14.50	11.50	975	7516432
	CSCF3642N6D*+TXV	A*EC960803BNA*	28,400	21,000	14.50	11.50	950	7516409
	CSCF3642N6D*+TXV	G*VM970603BNA*	28,600	21,200	14.50	11.50	1,040	7516434
	CSCF3642N6D*+TXV	G*E81005C*B*	28,600	21,200	14.50	11.50	1,070	7520286
CSCF3642N6D*+TXV	A*VC960603BNA*	28,800	21,400	14.50	11.50	1,040	7516415	
CSCF3642N6D*+TXV	G*VC960603BNA*	28,800	21,400	14.50	11.50	1,040	7516431	
CSCF3642N6D*+TXV	G*E80805C*B*	28,800	21,400	14.50	11.50	1,060	7516421	

¹ BTU/h

² Seasonal Energy Efficiency Ratio; Certified per AHRI 210/240 @ 80°F/ 67°F/ 95°F

³ Energy Efficiency Ratio @ 80°F/ 67°F/ 95°F

NOTES

- Always check the S&R plate for electrical data on the unit being installed.
- When matching the outdoor unit to the indoor unit, use the piston supplied with the outdoor unit or that specified on the piston kit chart supplied with the indoor unit.
- EEP - Order from Service Dept. Part No. B13707-38 or new Solid State Board B13707-35S. Part No. B13707-38 is not interchangeable with B13707-35S. The Goodman Gas Furnace contains the EEP cooling time delay

OUTDOOR UNIT	INDOOR UNITS		COOLING RATINGS				CFM	AHRI #
	COILS/AIR HANDLERS	FURNACES	TOTAL ¹	SENS. ¹	SEER ²	EER ³		
GSX14 0311K*	ASPT36C14A*		28,000	22,000	15.00	12.50	1,010	7516440
	AVPTC36C14A*		28,000	22,000	15.00	12.50	1,000	7516441
	AWUF31XX16A*		28,000	22,000	14.00	12.20	1,000	7516442
	AWUF31XX16A*+TXV		28,000	22,000	14.50	12.20	1,000	7516443
	AWUF32XX16A*		28,000	22,000	14.00	12.20	950	7516444
	AWUF32XX16A*+TXV		28,000	22,000	14.50	12.20	950	7516445
	AWUF37XX16B*		28,000	22,000	14.00	12.20	950	7516446
	AWUF37XX16B*+TXV		28,000	22,000	14.50	12.20	950	7516447
	CA*F3137*6A*	G*VM970603BNA*	28,400	22,400	15.00	12.50	1,040	7520313
	CA*F3137*6A*		28,600	22,600	14.50	12.20	1,000	7516448
	CA*F3137*6A*	G*E80603B*B*	28,400	22,400	14.50	12.20	1,050	7520299
	CA*F3137*6A*+EEP		28,600	22,600	14.00	12.20	1,000	7516452
	CA*F3137*6A*+EEP+TXV		28,600	22,600	14.00	12.20	1,000	7516453
	CA*F3137*6A*+TXV		28,600	22,600	15.00	12.50	1,000	7516449
	CA*F3743*6D*	A*VC960804CNA*	28,800	22,600	15.00	12.50	1,000	7516491
	CA*F3743*6D*	G*VC960804CNA*	28,800	22,600	15.00	12.50	1,000	7516493
	CA*F3743*6D*	A*VM970804CNA*	28,600	22,600	15.00	12.50	1,000	7516492
	CA*F3743*6D*	G*VM970804CNA*	28,600	22,600	15.00	12.50	1,000	7516494
	CA*F3743*6D*+TXV	G*E80805C*B*	28,600	22,600	15.00	12.50	1,000	7516475
	CA*F3743*6D*+TXV	A*VM970804CNA*	28,600	22,600	15.00	12.50	1,000	7516473
	CA*F3743*6D*+TXV	G*E81005C*B*	28,400	22,400	15.00	12.50	1,000	7516476
	CA*F3743*6D*+TXV	G*VC80805C*B*	28,600	22,600	15.00	12.50	990	7516483
	CA*F3743*6D*+TXV	A*EC960803BNA*	28,400	22,400	15.00	12.50	950	7516463
	CA*F3743*6D*+TXV	G*EC960302BNA*	28,400	22,400	15.00	12.50	940	7516477
	CA*F3743*6D*+TXV	G*VC960803BNA*	28,400	22,400	15.00	12.50	975	7516487
	CA*F3743*6D*+TXV	G*VC960603BNA*	28,600	22,600	15.00	12.50	1,040	7516486
	CA*F3743*6D*+TXV	G*VC960804CNA*	28,800	22,600	15.00	12.50	1,000	7516488
	CA*F3743*6D*+TXV	A*VC960403BNA*	28,800	22,600	15.00	12.50	1,000	7516468
	CA*F3743*6D*+TXV	G*VM970603BNA*	28,400	22,400	15.00	12.50	1,040	7516489
	CA*F3743*6D*+TXV	A*VM970603BNA*	28,400	22,400	15.00	12.50	1,040	7516472
	CA*F3743*6D*+TXV	A*EC961004CNA*	28,800	22,600	15.00	12.50	1,025	7516464
	CA*F3743*6D*+TXV	A*VC80604B*B*	28,600	22,600	15.00	12.50	1,000	7516465
	CA*F3743*6D*+TXV	A*VC960803BNA*	28,400	22,400	15.00	12.50	975	7516470
	CA*F3743*6D*+TXV	A*VC960603BNA*	28,600	22,600	15.00	12.50	1,040	7516469
	CA*F3743*6D*+TXV	A*VC81005C*B*	28,600	22,600	15.00	12.50	1,000	7516467
	CA*F3743*6D*+TXV	G*VC81005C*B*	28,600	22,600	15.00	12.50	1,000	7516484
	CA*F3743*6D*+TXV	A*EC960603BNA*	28,400	22,400	15.00	12.50	965	7516462
	CA*F3743*6D*+TXV	A*VC80805C*B*	28,600	22,600	15.00	12.50	990	7516466
	CA*F3743*6D*+TXV	G*EC960402BNA*	28,400	22,400	15.00	12.50	925	7516478
	CA*F3743*6D*+TXV	G*EC960603BNA*	28,400	22,400	15.00	12.50	965	7516479
	CA*F3743*6D*+TXV	A*EC960302BNA*	28,400	22,400	15.00	12.50	940	7516460
	CA*F3743*6D*+TXV	G*VM970804CNA*	28,600	22,600	15.00	12.50	1,000	7516490
	CA*F3743*6D*+TXV	A*VC960804CNA*	28,800	22,600	15.00	12.50	1,000	7516471
	CA*F3743*6D*+TXV	G*E80603B*B*	28,400	22,400	15.00	12.50	1,050	7516474
	CA*F3743*6D*+TXV	A*EC960402BNA*	28,400	22,400	15.00	12.50	925	7516461
	CA*F3743*6D*+TXV	G*EC961004CNA*	28,800	22,600	15.00	12.50	1,025	7516481
	CA*F3743*6D*+TXV	G*EC960803BNA*	28,400	22,400	15.00	12.50	950	7516480
	CA*F3743*6D*+TXV	G*VC80604B*B*	28,600	22,600	15.00	12.50	1,000	7516482
	CA*F3743*6D*+TXV	G*VC960403BNA*	28,800	22,600	15.00	12.50	1,000	7516485
	CAPT3743*4A*	A*EC960402BNA*	28,200	22,200	14.50	12.20	925	7516499
CAPT3743*4A*	G*E81005C*B*	28,400	22,400	14.50	12.00	1,000	7516514	
CAPT3743*4A*	A*VC81005C*B*	28,400	22,400	14.50	12.20	1,000	7516505	
CAPT3743*4A*	G*EC960603BNA*	28,200	22,200	14.50	12.00	965	7516517	

See Notes on Page 44.

OUTDOOR UNIT	INDOOR UNITS		COOLING RATINGS				CFM	AHRI #
	COILS/AIR HANDLERS	FURNACES	TOTAL ¹	SENS. ¹	SEER ²	EER ³		
GSX14 0311K* (cont.)	CAPT3743*4A*	A*EC961004CNA*	28,600	22,600	14.50	12.20	1,025	7516502
	CAPT3743*4A*	A*VC80805C*B*	28,400	22,400	14.50	12.00	990	7516504
	CAPT3743*4A*	A*VC960804CNA*	28,400	22,400	14.50	12.20	1,000	7516509
	CAPT3743*4A*	A*EC960302BNA*	28,200	22,200	14.50	12.20	940	7516498
	CAPT3743*4A*	G*EC961004CNA*	28,600	22,600	14.50	12.20	1,025	7516519
	CAPT3743*4A*	G*EC960803BNA*	28,200	22,200	14.50	12.20	950	7516518
	CAPT3743*4A*	G*VC81005C*B*	28,400	22,400	14.50	12.20	1,000	7516522
	CAPT3743*4A*	G*EC960302BNA*	28,200	22,200	14.50	12.20	940	7516515
	CAPT3743*4A*	A*VC960403BNA*	28,400	22,400	14.50	12.20	1,000	7516506
	CAPT3743*4A*	G*E80805C*B*	28,400	22,400	14.50	12.20	1,000	7516513
	CAPT3743*4A*	G*VC80805C*B*	28,400	22,400	14.50	12.00	990	7516521
	CAPT3743*4A*	A*VC960603BNA*	28,400	22,400	14.50	12.20	1,040	7516507
	CAPT3743*4A*	G*VC960603BNA*	28,400	22,400	14.50	12.20	1,040	7516524
	CAPT3743*4A*	A*VC960803BNA*	27,800	21,800	15.00	12.50	975	7516508
	CAPT3743*4A*	G*E80603B*B*	28,400	22,400	14.50	12.20	1,050	7516512
	CAPT3743*4A*	A*EC960803BNA*	28,200	22,200	14.50	12.20	950	7516501
	CAPT3743*4A*	G*EC960402BNA*	28,200	22,200	14.50	12.20	925	7516516
	CAPT3743*4A*	A*VM970804CNA*	28,400	22,400	14.50	12.20	1,000	7516511
	CAPT3743*4A*	G*VC960804CNA*	28,400	22,400	14.50	12.20	1,000	7516526
	CAPT3743*4A*	A*VC80604B*B*	28,400	22,400	14.50	12.20	1,000	7516503
	CAPT3743*4A*	A*EC960603BNA*	28,200	22,200	14.50	12.00	965	7516500
	CAPT3743*4A*	G*VM970603BNA*	28,400	22,400	15.00	12.50	1,040	7516527
	CAPT3743*4A*	G*VC960803BNA*	27,800	21,800	15.00	12.50	975	7516525
	CAPT3743*4A*	G*VM970804CNA*	28,400	22,400	14.50	12.20	1,000	7516528
	CAPT3743*4A*	G*VC80604B*B*	28,400	22,400	14.50	12.20	1,000	7516520
	CAPT3743*4A*	A*VM970603BNA*	28,400	22,400	15.00	12.50	1,040	7516510
	CAPT3743*4A*	G*VC960403BNA*	28,400	22,400	14.50	12.20	1,000	7516523
	CAPT3743*4A*+EEP		28,000	22,000	14.50	12.20	1,000	7516495
	CAPT3743*4A*+MBVC1200**-1A*		28,600	22,600	15.00	12.50	1,000	7516496
	CAPT3743*4A*+MBVC1600**-1A*		28,600	22,600	15.00	12.50	1,000	7516497
	CHPF3636B6C*+TXV	G*VC960403BNA*	28,000	22,000	14.50	12.50	1,000	7516533
	CHPF3636B6C*+TXV	G*VC960603BNA*	28,000	22,000	14.50	12.20	1,040	7516534
	CHPF3636B6C*+TXV	G*VC960803BNA*	28,000	22,000	14.50	12.20	975	7516535
	CHPF3636B6C*+TXV	G*VM970603BNA*	28,000	22,000	14.50	12.20	1,040	7516536
	CHPF3636B6C*+TXV	A*VC960803BNA*	28,000	22,000	14.50	12.20	975	7516531
	CHPF3636B6C*+TXV	A*VC960603BNA*	28,000	22,000	14.50	12.20	1,040	7516530
	CHPF3636B6C*+TXV	A*VM970603BNA*	28,000	22,000	14.50	12.20	1,040	7516532
	CHPF3636B6C*+TXV	A*VC960403BNA*	28,000	22,000	14.50	12.50	1,000	7516529
	CHPF3642C6C*+EEP		28,600	22,600	14.00	12.20	1,000	7516537
	CHPF3642C6C*+EEP+TXV		28,000	22,000	14.50	12.20	1,000	7516538
	CHPF3642C6C*+MBVC1200**-1A*		28,000	22,000	14.50	12.20	1,000	7519537
	CHPF3642C6C*+MBVC1200**-1A*+TXV		28,000	22,000	14.50	12.20	1,000	7516539
	CHPF3642C6C*+MBVC1600**-1A*		28,000	22,000	14.50	12.20	1,000	7516540
	CHPF3642C6C*+MBVC1600**-1A*+TXV		28,400	22,400	15.00	12.50	1,000	7516541
	CHPF3642C6C*+TXV	G*E80603B*B*	28,000	22,000	14.50	12.20	1,050	7516547
	CHPF3642C6C*+TXV	G*VC80604B*B*	28,000	22,000	14.50	12.20	1,000	7516552
	CHPF3642C6C*+TXV	A*EC960603BNA*	28,400	22,400	14.50	12.20	965	7516544
	CHPF3642C6C*+TXV	A*EC960302BNA*	28,400	22,400	14.50	12.20	940	7516542
CHPF3642C6C*+TXV	A*EC960803BNA*	28,400	22,400	14.50	12.20	950	7516545	
CHPF3642C6C*+TXV	G*EC960603BNA*	28,400	22,400	14.50	12.20	965	7516550	
CHPF3642C6C*+TXV	G*EC960302BNA*	28,400	22,400	14.50	12.20	940	7516548	
CHPF3642C6C*+TXV	A*VC80604B*B*	28,000	22,000	14.50	12.20	1,000	7516546	
CHPF3642C6C*+TXV	G*EC960402BNA*	28,400	22,400	15.00	12.50	925	7516549	
CHPF3642C6C*+TXV	G*EC960803BNA*	28,400	22,400	14.50	12.20	950	7516551	

See Notes on Page 44.

OUTDOOR UNIT	INDOOR UNITS		COOLING RATINGS				CFM	AHRI #
	COILS/AIR HANDLERS	FURNACES	TOTAL ¹	SENS. ¹	SEER ²	EER ³		
GSX14 0311K* (cont.)	CHPF3642C6C*+TXV	A*EC960402BNA*	28,400	22,400	15.00	12.50	925	7516543
	CHPF3642D6C*	G*VC960804CNA*	28,600	22,600	14.50	12.20	1,000	7516567
	CHPF3642D6C*	A*VM970804CNA*	28,600	22,600	14.50	12.20	1,000	7516566
	CHPF3642D6C*	G*VM970804CNA*	28,600	22,600	14.50	12.20	1,000	7516568
	CHPF3642D6C*	A*VC960804CNA*	28,600	22,600	14.50	12.20	1,000	7516565
	CHPF3642D6C*+TXV	A*VC80805C*B*	28,600	22,600	15.00	12.50	990	7516554
	CHPF3642D6C*+TXV	A*VM970804CNA*	28,600	22,600	14.50	12.20	1,000	7516557
	CHPF3642D6C*+TXV	G*VC81005C*B*	28,600	22,600	14.50	12.20	1,000	7516562
	CHPF3642D6C*+TXV	G*EC961004CNA*	28,800	22,600	15.00	12.50	1,025	7516560
	CHPF3642D6C*+TXV	G*VC80805C*B*	28,600	22,600	15.00	12.50	990	7516561
	CHPF3642D6C*+TXV	G*E81005C*B*	28,600	22,600	15.00	12.50	1,000	7516559
	CHPF3642D6C*+TXV	G*E80805C*B*	28,000	22,000	15.00	12.50	1,000	7516558
	CHPF3642D6C*+TXV	G*VM970804CNA*	28,600	22,600	14.50	12.20	1,000	7516564
	CHPF3642D6C*+TXV	A*VC81005C*B*	28,600	22,600	14.50	12.20	1,000	7516555
	CHPF3642D6C*+TXV	G*VC960804CNA*	28,600	22,600	14.50	12.20	1,000	7516563
	CHPF3642D6C*+TXV	A*EC961004CNA*	28,800	22,600	15.00	12.50	1,025	7516553
	CHPF3642D6C*+TXV	A*VC960804CNA*	28,600	22,600	14.50	12.20	1,000	7516556
	CSCF3642N6D*	G*VM970804CNA*	28,600	22,600	15.00	12.50	1,000	7516605
	CSCF3642N6D*	A*VM970804CNA*	28,600	22,600	15.00	12.50	1,000	7516603
	CSCF3642N6D*	G*VC960804CNA*	28,800	22,600	15.00	12.50	1,000	7516604
	CSCF3642N6D*	A*VC960804CNA*	28,800	22,600	15.00	12.50	1,000	7516602
	CSCF3642N6D*+EEP		28,400	22,400	14.00	12.20	1,000	7516569
	CSCF3642N6D*+EEP+TXV		28,400	22,400	14.50	12.20	1,000	7516570
	CSCF3642N6D*+TXV	G*EC960603BNA*	28,400	22,400	14.50	12.20	965	7516590
	CSCF3642N6D*+TXV	G*VC80604B*B*	28,600	22,600	15.00	12.50	1,000	7516593
	CSCF3642N6D*+TXV	G*VM970804CNA*	28,600	22,600	15.00	12.50	1,000	7516601
	CSCF3642N6D*+TXV	G*EC960803BNA*	28,400	22,400	14.50	12.20	950	7516591
	CSCF3642N6D*+TXV	A*VC960403BNA*	28,600	22,600	15.00	12.50	1,000	7516579
	CSCF3642N6D*+TXV	A*VC960803BNA*	28,400	22,400	15.00	12.50	975	7516581
	CSCF3642N6D*+TXV	A*VC81005C*B*	28,600	22,600	15.00	12.50	1,000	7516578
	CSCF3642N6D*+TXV	A*EC960803BNA*	28,400	22,400	14.50	12.20	950	7516574
	CSCF3642N6D*+TXV	A*VC960603BNA*	28,400	22,400	15.00	12.50	1,040	7516580
	CSCF3642N6D*+TXV	A*EC960402BNA*	28,400	22,400	14.50	12.20	925	7516572
	CSCF3642N6D*+TXV	G*VC960603BNA*	28,400	22,400	15.00	12.50	1,040	7516597
	CSCF3642N6D*+TXV	G*EC960402BNA*	28,400	22,400	14.50	12.20	925	7516589
	CSCF3642N6D*+TXV	G*E80805C*B*	28,400	22,400	15.00	12.50	1,000	7516586
	CSCF3642N6D*+TXV	G*VC80805C*B*	28,400	22,400	15.00	12.50	990	7516594
	CSCF3642N6D*+TXV	G*VC960403BNA*	28,600	22,600	15.00	12.50	1,000	7516596
	CSCF3642N6D*+TXV	A*VC960804CNA*	28,800	22,600	15.00	12.50	1,000	7516582
	CSCF3642N6D*+TXV	G*VC960804CNA*	28,800	22,600	15.00	12.50	1,000	7516599
	CSCF3642N6D*+TXV	A*EC960603BNA*	28,400	22,400	14.50	12.20	965	7516573
	CSCF3642N6D*+TXV	A*EC960302BNA*	28,400	22,400	14.50	12.20	940	7516571
CSCF3642N6D*+TXV	A*EC961004CNA*	28,400	22,400	14.50	12.20	1,025	7516575	
CSCF3642N6D*+TXV	G*E80603B*B*	28,600	22,600	15.00	12.50	1,050	7516585	
CSCF3642N6D*+TXV	A*VC80805C*B*	28,400	22,400	15.00	12.50	990	7516577	
CSCF3642N6D*+TXV	G*VC960803BNA*	28,400	22,400	15.00	12.50	975	7516598	
CSCF3642N6D*+TXV	A*VC80604B*B*	28,600	22,600	15.00	12.50	1,000	7516576	
CSCF3642N6D*+TXV	G*EC960302BNA*	28,400	22,400	14.50	12.20	940	7516588	
CSCF3642N6D*+TXV	A*VM970603BNA*	28,400	22,400	15.00	12.50	1,040	7516583	
CSCF3642N6D*+TXV	G*VM970603BNA*	28,400	22,400	15.00	12.50	1,040	7516600	
CSCF3642N6D*+TXV	G*EC961004CNA*	28,400	22,400	14.50	12.20	1,025	7516592	
CSCF3642N6D*+TXV	G*E81005C*B*	28,400	22,400	15.00	12.50	1,000	7516587	
CSCF3642N6D*+TXV	A*VM970804CNA*	28,600	22,600	15.00	12.50	1,000	7516584	
CSCF3642N6D*+TXV	G*VC81005C*B*	28,600	22,600	15.00	12.50	1,000	7516595	

See Notes on Page 44.

OUTDOOR UNIT	INDOOR UNITS		COOLING RATINGS				CFM	AHRI #
	COILS/AIR HANDLERS	FURNACES	TOTAL ¹	SENS. ¹	SEER ²	EER ³		
GSX14 0361K*	ASPT36C14A*		34,200	25,400	14.50	11.50	1,210	7516606
	ASPT42D14A*		34,800	25,800	14.50	12.00	1,280	7516607
	AVPTC36C14A*		34,200	25,400	14.50	11.50	1,100	7516608
	AVPTC42D14A*		34,800	25,800	14.50	12.00	1,120	7516609
	AWUF37XX16B*+TXV		33,000	24,400	14.50	11.50	1,050	7516610
	CA*F3642*6D*+EEP		34,000	25,200	14.00	11.50	1,200	7516611
	CA*F3642*6D*+EEP+TXV		34,000	25,200	14.00	11.50	1,200	7516612
	CA*F3642*6D*+MBVC1600**-1A*		34,000	25,200	14.50	11.50	1,200	7516613
	CA*F3642*6D*+MBVC2000**-1A*		34,000	25,200	14.50	12.00	1,200	7516614
	CA*F3743*6D*	G*EC961205DNA*	34,000	25,200	14.50	11.50	1,075	7516671
	CA*F3743*6D*	G*VC960804CNA*	34,600	25,600	14.50	11.50	1,190	7516674
	CA*F3743*6D*	G*E81005C*B*	34,000	25,200	14.50	11.50	1,230	7516669
	CA*F3743*6D*	G*VC80805C*B*	33,600	25,000	14.50	11.50	1,200	7516672
	CA*F3743*6D*	A*VM971205DNA*	34,600	25,600	14.50	11.50	1,200	7516667
	CA*F3743*6D*	G*VM970804CNA*	34,600	25,600	14.50	11.50	1,190	7516677
	CA*F3743*6D*	A*EC961205DNA*	34,000	25,200	14.50	11.50	1,075	7516659
	CA*F3743*6D*	G*VC961005CNA*	34,600	25,600	14.50	11.50	1,175	7516675
	CA*F3743*6D*	A*VC80805C*B*	33,600	25,000	14.50	11.50	1,200	7516660
	CA*F3743*6D*	G*VM971005CNA*	34,600	25,600	14.50	11.50	1,175	7516678
	CA*F3743*6D*	G*VC961205DNA*	34,600	25,600	14.50	11.50	1,200	7516676
	CA*F3743*6D*	A*VM971005CNA*	34,600	25,600	14.50	11.50	1,175	7516666
	CA*F3743*6D*	G*VM971205DNA*	34,600	25,600	14.50	11.50	1,200	7516679
	CA*F3743*6D*	A*VC961005CNA*	34,600	25,600	14.50	11.50	1,175	7516663
	CA*F3743*6D*	A*VC960804CNA*	34,600	25,600	14.50	11.50	1,190	7516662
	CA*F3743*6D*	G*EC961004CNA*	34,600	25,600	14.50	11.50	1,250	7516670
	CA*F3743*6D*	A*VC81005C*B*	33,400	24,800	14.50	11.50	1,200	7516661
	CA*F3743*6D*	A*VM970804CNA*	34,600	25,600	14.50	11.50	1,190	7516665
	CA*F3743*6D*	A*EC961004CNA*	34,600	25,600	14.50	11.50	1,250	7516658
	CA*F3743*6D*	G*E80805C*B*	33,600	25,000	14.50	11.50	1,210	7516668
	CA*F3743*6D*	A*VC961205DNA*	34,600	25,600	14.50	11.50	1,200	7516664
	CA*F3743*6D*	G*VC81005C*B*	33,400	24,800	14.50	11.50	1,200	7516673
	CA*F3743*6D*+EEP		34,600	25,600	14.00	11.50	1,200	7516615
	CA*F3743*6D*+EEP+TXV		34,600	25,600	14.50	11.50	1,200	7516616
	CA*F3743*6D*+MBVC1600**-1A*		35,000	26,000	14.50	11.50	1,200	7516617
	CA*F3743*6D*+MBVC2000**-1A*		35,000	26,000	14.50	11.50	1,200	7516618
	CA*F3743*6D*+TXV	G*VC960403BNA*	34,200	25,400	14.50	11.50	1,200	7516647
	CA*F3743*6D*+TXV	A*VM970803BNA*	34,400	25,400	14.50	11.50	1,250	7516633
	CA*F3743*6D*+TXV	G*EC961205DNA*	34,000	25,200	14.50	12.00	1,075	7516643
	CA*F3743*6D*+TXV	G*VC961205DNA*	34,600	25,600	14.50	12.00	1,200	7516652
	CA*F3743*6D*+TXV	A*VM970804CNA*	34,600	25,600	14.50	11.50	1,190	7516634
	CA*F3743*6D*+TXV	G*VC80805C*B*	33,600	25,000	14.50	12.00	1,200	7516645
	CA*F3743*6D*+TXV	A*EC960603BNA*	34,200	25,400	14.50	11.50	1,150	7516619
	CA*F3743*6D*+TXV	G*E80805C*B*	33,600	25,000	14.50	11.50	1,210	7516638
	CA*F3743*6D*+TXV	G*VC960804CNA*	34,600	25,600	14.50	12.00	1,190	7516650
CA*F3743*6D*+TXV	A*VM970603BNA*	34,400	25,400	14.50	11.50	1,250	7516632	
CA*F3743*6D*+TXV	G*VC960803BNA*	34,400	25,400	14.50	11.50	1,250	7516649	
CA*F3743*6D*+TXV	A*VC961005CNA*	34,600	25,600	14.50	12.00	1,175	7516630	
CA*F3743*6D*+TXV	A*VC960403BNA*	34,200	25,400	14.50	11.50	1,200	7516626	
CA*F3743*6D*+TXV	G*VC81005C*B*	33,400	24,800	14.50	12.00	1,200	7516646	
CA*F3743*6D*+TXV	A*VC80604B*B*	33,600	25,000	14.50	11.50	1,220	7516623	
CA*F3743*6D*+TXV	G*VC80604B*B*	33,600	25,000	14.50	11.50	1,220	7516644	
CA*F3743*6D*+TXV	G*E81005C*B*	34,000	25,200	14.50	11.50	1,230	7516639	
CA*F3743*6D*+TXV	A*VC81005C*B*	33,400	24,800	14.50	12.00	1,200	7516625	

See Notes on Page 44.

OUTDOOR UNIT	INDOOR UNITS		COOLING RATINGS				CFM	AHRI #
	COILS/AIR HANDLERS	FURNACES	TOTAL ¹	SENS. ¹	SEER ²	EER ³		
GSX14 0361K* (cont.)	CA*F3743*6D*+TXV	G*VM970803BNA*	34,400	25,400	14.50	11.50	1,250	7516654
	CA*F3743*6D*+TXV	G*E80603B*B*	33,400	24,800	14.50	11.50	1,250	7516637
	CA*F3743*6D*+TXV	G*VC961005CNA*	34,600	25,600	14.50	12.00	1,175	7516651
	CA*F3743*6D*+TXV	G*VM971005CNA*	34,600	25,600	14.50	11.50	1,175	7516656
	CA*F3743*6D*+TXV	A*VC960603BNA*	34,400	25,400	14.50	11.50	1,250	7516627
	CA*F3743*6D*+TXV	A*VC961205DNA*	34,600	25,600	14.50	12.00	1,200	7516631
	CA*F3743*6D*+TXV	G*EC960603BNA*	34,200	25,400	14.50	11.50	1,150	7516640
	CA*F3743*6D*+TXV	G*EC961004CNA*	34,600	25,600	14.50	11.50	1,250	7516642
	CA*F3743*6D*+TXV	A*VM971005CNA*	34,600	25,600	14.50	11.50	1,175	7516635
	CA*F3743*6D*+TXV	A*VM971205DNA*	34,600	25,600	14.50	12.00	1,200	7516636
	CA*F3743*6D*+TXV	A*EC961205DNA*	34,000	25,200	14.50	12.00	1,075	7516622
	CA*F3743*6D*+TXV	G*VC960603BNA*	34,400	25,400	14.50	11.50	1,250	7516648
	CA*F3743*6D*+TXV	G*VM971205DNA*	34,600	25,600	14.50	12.00	1,200	7516657
	CA*F3743*6D*+TXV	A*EC960803BNA*	34,200	25,400	14.50	11.50	1,150	7516620
	CA*F3743*6D*+TXV	A*VC80805C*B*	33,600	25,000	14.50	12.00	1,200	7516624
	CA*F3743*6D*+TXV	G*VM970603BNA*	34,400	25,400	14.50	11.50	1,250	7516653
	CA*F3743*6D*+TXV	A*VC960804CNA*	34,600	25,600	14.50	12.00	1,190	7516629
	CA*F3743*6D*+TXV	A*VC960803BNA*	34,400	25,400	14.50	11.50	1,250	7516628
	CA*F3743*6D*+TXV	G*VM970804CNA*	34,600	25,600	14.50	11.50	1,190	7516655
	CA*F3743*6D*+TXV	G*EC960803BNA*	34,200	25,400	14.50	11.50	1,150	7516641
	CA*F3743*6D*+TXV	A*EC961004CNA*	34,600	25,600	14.50	11.50	1,250	7516621
	CA*F4860*6D*+EEP		34,800	25,800	14.00	11.50	1,200	7516680
	CA*F4860*6D*+EEP+TXV		34,800	25,800	14.00	11.50	1,200	7516681
	CAPT3743*4A*	A*EC960803BNA*	34,200	25,400	14.00	11.50	1,150	7516683
	CAPT3743*4A*	G*VM971005CNA*	34,600	25,600	14.50	11.50	1,175	7516713
	CAPT3743*4A*	A*VM971205DNA*	34,400	25,400	14.50	11.50	1,200	7516697
	CAPT3743*4A*	A*VM970804CNA*	34,600	25,600	14.50	11.50	1,190	7516695
	CAPT3743*4A*	A*VC960804CNA*	34,600	25,600	14.50	11.50	1,190	7516690
	CAPT3743*4A*	G*VC961005CNA*	34,600	25,600	14.50	11.50	1,175	7516708
	CAPT3743*4A*	A*VM971005CNA*	34,600	25,600	14.50	11.50	1,175	7516696
	CAPT3743*4A*	A*VC960803BNA*	34,200	25,400	14.50	11.50	1,250	7516689
	CAPT3743*4A*	A*VC961005CNA*	34,600	25,600	14.50	11.50	1,175	7516691
	CAPT3743*4A*	G*VM970603BNA*	34,200	25,400	14.50	11.50	1,250	7516710
	CAPT3743*4A*	G*VC960803BNA*	34,200	25,400	14.50	11.50	1,250	7516706
	CAPT3743*4A*	A*VM970803BNA*	34,200	25,400	14.50	11.50	1,250	7516694
	CAPT3743*4A*	G*VC960403BNA*	34,000	25,200	14.50	11.50	1,200	7516704
	CAPT3743*4A*	G*EC961004CNA*	34,600	25,600	14.50	11.50	1,250	7516721
	CAPT3743*4A*	G*E81005C*B*	34,000	25,200	14.50	11.50	1,230	7516699
	CAPT3743*4A*	A*EC960603BNA*	34,200	25,400	14.00	11.50	1,150	7516717
	CAPT3743*4A*	G*VC81005C*B*	33,400	24,800	14.50	11.50	1,200	7516703
	CAPT3743*4A*	A*VC960403BNA*	34,000	25,200	14.50	11.50	1,200	7516687
	CAPT3743*4A*	G*VC961205DNA*	34,400	25,400	14.50	11.50	1,200	7516709
CAPT3743*4A*	G*EC961205DNA*	34,000	25,200	14.50	11.50	1,075	7516722	
CAPT3743*4A*	G*VM970804CNA*	34,600	25,600	14.50	11.50	1,190	7516712	
CAPT3743*4A*	A*EC961205DNA*	34,000	25,200	14.50	11.50	1,075	7516719	
CAPT3743*4A*	G*EC960603BNA*	34,200	25,400	14.00	11.50	1,150	7516720	
CAPT3743*4A*	G*VC960804CNA*	34,600	25,600	14.50	11.50	1,190	7516707	
CAPT3743*4A*	G*E80805C*B*	33,600	25,000	14.50	11.50	1,210	7516698	
CAPT3743*4A*	G*VM970803BNA*	34,200	25,400	14.50	11.50	1,250	7516711	
CAPT3743*4A*	G*VC960603BNA*	34,200	25,400	14.50	11.50	1,250	7516705	
CAPT3743*4A*	G*VM971205DNA*	34,400	25,400	14.50	11.50	1,200	7516714	
CAPT3743*4A*	A*VC80805C*B*	33,600	25,000	14.50	11.50	1,200	7516685	
CAPT3743*4A*	A*VC960603BNA*	34,200	25,400	14.50	11.50	1,250	7516688	

See Notes on Page 44.

OUTDOOR UNIT	INDOOR UNITS		COOLING RATINGS				CFM	AHRI #
	COILS/AIR HANDLERS	FURNACES	TOTAL ¹	SENS. ¹	SEER ²	EER ³		
GSX14 0361K* (cont.)	CAPT3743*4A*	A*EC961004CNA*	34,600	25,600	14.50	11.50	1,250	7516718
	CAPT3743*4A*	A*VM970603BNA*	34,200	25,400	14.50	11.50	1,250	7516693
	CAPT3743*4A*	A*VC80604B*B*	33,600	25,000	14.50	11.50	1,220	7516684
	CAPT3743*4A*	G*VC80805C*B*	33,600	25,000	14.50	11.50	1,200	7516702
	CAPT3743*4A*	A*VC81005C*B*	33,400	24,800	14.50	11.50	1,200	7516686
	CAPT3743*4A*	G*VC80604B*B*	33,600	25,000	14.50	11.50	1,220	7516701
	CAPT3743*4A*	A*VC961205DNA*	34,400	25,400	14.50	11.50	1,200	7516692
	CAPT3743*4A*	G*EC960803BNA*	34,200	25,400	14.00	11.50	1,150	7516700
	CAPT3743*4A*+EEP		34,600	25,600	14.50	11.50	1,200	7516682
	CAPT3743*4A*+MBVC1600**-1A*		34,000	25,200	14.50	11.50	1,205	7516715
	CAPT3743*4A*+MBVC2000**-1A*		34,000	25,200	14.50	11.50	1,205	7516716
	CHPF3642C6C*	G*E81005C*B*	34,000	25,200	14.50	11.50	1,230	7516732
	CHPF3642C6C*	G*E80805C*B*	33,600	25,000	14.50	11.50	1,210	7516731
	CHPF3642C6C*+EEP		34,600	25,600	14.00	11.50	1,200	7516723
	CHPF3642C6C*+EEP+TXV		34,600	25,600	14.00	11.50	1,200	7516724
	CHPF3642C6C*+MBVC1600**-1A*		35,000	26,000	14.50	11.50	1,200	7516733
	CHPF3642C6C*+TXV	G*E81005C*B*	34,000	25,200	14.50	12.00	1,230	7516728
	CHPF3642C6C*+TXV	G*EC960803BNA*	34,200	25,400	14.50	11.50	1,150	7516730
	CHPF3642C6C*+TXV	A*EC960803BNA*	34,200	25,400	14.50	11.50	1,150	7516726
	CHPF3642C6C*+TXV	G*E80805C*B*	33,600	25,000	14.50	11.50	1,210	7516727
	CHPF3642C6C*+TXV	A*EC960603BNA*	34,200	25,400	14.50	11.50	1,150	7516725
	CHPF3642C6C*+TXV	G*E80603B*B*	33,400	24,800	14.50	11.50	1,250	7516734
	CHPF3642C6C*+TXV	G*EC960603BNA*	34,200	25,400	14.50	11.50	1,150	7516729
	CHPF3743C6B*	A*VC80805C*B*	33,600	25,000	14.50	11.50	1,200	7516761
	CHPF3743C6B*	G*VC80805C*B*	33,600	25,000	14.50	11.50	1,200	7516766
	CHPF3743C6B*	A*VC960804CNA*	34,600	25,600	14.50	11.50	1,190	7516763
	CHPF3743C6B*	A*VM970804CNA*	34,600	25,600	14.50	11.50	1,190	7516765
	CHPF3743C6B*	G*VC961005CNA*	34,600	25,600	14.50	11.50	1,175	7516769
	CHPF3743C6B*	G*VC81005C*B*	33,400	24,800	14.50	11.50	1,200	7516767
	CHPF3743C6B*	A*EC961004CNA*	34,600	25,600	14.50	11.50	1,250	7516774
	CHPF3743C6B*	G*VM970804CNA*	34,600	25,600	14.50	11.50	1,190	7516770
	CHPF3743C6B*	A*VM971005CNA*	34,600	25,600	14.50	11.50	1,175	7520314
	CHPF3743C6B*	A*VC961005CNA*	34,600	25,600	14.50	11.50	1,175	7516764
	CHPF3743C6B*	G*EC961004CNA*	34,600	25,600	14.50	11.50	1,250	7516775
	CHPF3743C6B*	A*VC81005C*B*	33,400	24,800	14.50	11.50	1,200	7516762
	CHPF3743C6B*	G*VC960804CNA*	34,600	25,600	14.50	11.50	1,190	7516768
	CHPF3743C6B*	G*VM971005CNA*	34,600	25,600	14.50	11.50	1,175	7520315
	CHPF3743C6B*+EEP		34,000	25,200	14.00	11.50	1,150	7516735
	CHPF3743C6B*+EEP+TXV		34,000	25,200	14.50	11.50	1,150	7516736
	CHPF3743C6B*+MBVC1600**-1A*		35,000	26,000	14.50	11.50	1,200	7516771
	CHPF3743C6B*+TXV	A*VC960603BNA*	34,400	25,400	14.50	11.50	1,250	7516741
	CHPF3743C6B*+TXV	A*VC960804CNA*	34,600	25,600	14.50	12.00	1,190	7516743
	CHPF3743C6B*+TXV	A*VM970803BNA*	34,400	25,400	14.50	11.50	1,250	7516746
	CHPF3743C6B*+TXV	G*VC961005CNA*	34,600	25,600	14.50	12.00	1,175	7516756
	CHPF3743C6B*+TXV	G*VM971005CNA*	34,600	25,600	14.50	11.50	1,175	7516760
	CHPF3743C6B*+TXV	A*VC80604B*B*	33,600	25,000	14.50	11.50	1,220	7516737
	CHPF3743C6B*+TXV	G*VM970804CNA*	34,600	25,600	14.50	11.50	1,190	7516759
	CHPF3743C6B*+TXV	G*VC80805C*B*	33,600	25,000	14.50	12.00	1,200	7516750
	CHPF3743C6B*+TXV	A*EC961004CNA*	34,600	25,600	14.50	11.50	1,250	7516772
	CHPF3743C6B*+TXV	A*VC81005C*B*	33,400	24,800	14.50	12.00	1,200	7516739
CHPF3743C6B*+TXV	A*VC961005CNA*	34,600	25,600	14.50	12.00	1,175	7516744	
CHPF3743C6B*+TXV	G*VC960603BNA*	34,400	25,400	14.50	11.50	1,250	7516753	
CHPF3743C6B*+TXV	G*EC961004CNA*	34,600	25,600	14.50	11.50	1,250	7516773	

See Notes on Page 56.

OUTDOOR UNIT	INDOOR UNITS		COOLING RATINGS				CFM	AHRI #
	COILS/AIR HANDLERS	FURNACES	TOTAL ¹	SENS. ¹	SEER ²	EER ³		
GSX14 0361K* (cont.)	CHPF3743C6B*+TXV	G*VC960803BNA*	34,400	25,400	14.50	11.50	1,250	7516754
	CHPF3743C6B*+TXV	G*VM970803BNA*	34,400	25,400	14.50	11.50	1,250	7516758
	CHPF3743C6B*+TXV	G*VC80604B*B*	33,600	25,000	14.50	11.50	1,220	7516749
	CHPF3743C6B*+TXV	A*VC960403BNA*	34,200	25,400	14.50	11.50	1,200	7516740
	CHPF3743C6B*+TXV	A*VC960803BNA*	34,400	25,400	14.50	11.50	1,250	7516742
	CHPF3743C6B*+TXV	G*VC960403BNA*	34,200	25,400	14.50	11.50	1,200	7516752
	CHPF3743C6B*+TXV	G*VC960804CNA*	34,600	25,600	14.50	12.00	1,190	7516755
	CHPF3743C6B*+TXV	A*VM970603BNA*	34,400	25,400	14.50	11.50	1,250	7516745
	CHPF3743C6B*+TXV	G*VM970603BNA*	34,400	25,400	14.50	11.50	1,250	7516757
	CHPF3743C6B*+TXV	A*VM970804CNA*	34,600	25,600	14.50	11.50	1,190	7516747
	CHPF3743C6B*+TXV	G*VC81005C*B*	33,400	24,800	14.50	12.00	1,200	7516751
	CHPF3743C6B*+TXV	A*VM971005CNA*	34,600	25,600	14.50	11.50	1,175	7516748
	CHPF3743C6B*+TXV	A*VC80805C*B*	33,600	25,000	14.50	12.00	1,200	7516738
	CHPF3743D6B*	A*EC961205DNA*	34,000	25,200	14.50	11.50	1,075	7516788
	CHPF3743D6B*	G*VC961205DNA*	34,600	25,600	14.50	11.50	1,200	7516786
	CHPF3743D6B*	A*VC961205DNA*	34,600	25,600	14.50	11.50	1,200	7516784
	CHPF3743D6B*	G*VM971205DNA*	34,600	25,600	14.50	11.50	1,200	7516787
	CHPF3743D6B*	G*EC961205DNA*	34,000	25,200	14.50	11.50	1,075	7516789
	CHPF3743D6B*	A*VM971205DNA*	34,600	25,600	14.50	11.50	1,200	7516785
	CHPF3743D6B*+EEP		34,600	25,600	14.50	11.50	1,150	7516776
	CHPF3743D6B*+EEP+TXV		34,600	25,600	14.50	12.00	1,150	7516777
	CHPF3743D6B*+TXV	A*EC961205DNA*	34,000	25,200	14.50	12.00	1,075	7516778
	CHPF3743D6B*+TXV	G*VM971205DNA*	34,600	25,600	14.50	12.00	1,200	7516783
	CHPF3743D6B*+TXV	G*VC961205DNA*	34,600	25,600	14.50	12.00	1,200	7516782
	CHPF3743D6B*+TXV	G*EC961205DNA*	34,000	25,200	14.50	12.00	1,075	7516781
	CHPF3743D6B*+TXV	A*VC961205DNA*	34,600	25,600	14.50	12.00	1,200	7516779
	CHPF3743D6B*+TXV	A*VM971205DNA*	34,600	25,600	14.50	12.00	1,200	7516780
	CSCF4860N6D*	G*E80805C*B*	33,600	25,000	14.50	11.50	1,210	7516830
	CSCF4860N6D*	A*VC81005C*B*	33,400	24,800	14.50	11.50	1,200	7516823
	CSCF4860N6D*	A*VC80805C*B*	33,600	25,000	14.50	11.50	1,200	7516822
	CSCF4860N6D*	G*VC961005CNA*	34,600	25,600	14.50	11.50	1,175	7516835
	CSCF4860N6D*	G*VM971005CNA*	34,600	25,600	14.50	11.50	1,175	7516838
	CSCF4860N6D*	A*VM970804CNA*	34,600	25,600	14.50	11.50	1,190	7516827
	CSCF4860N6D*	A*VM971005CNA*	34,600	25,600	14.50	11.50	1,175	7516828
	CSCF4860N6D*	G*VM971205DNA*	34,600	25,600	14.50	11.50	1,200	7516839
	CSCF4860N6D*	G*VC960804CNA*	34,600	25,600	14.50	11.50	1,190	7516834
	CSCF4860N6D*	A*VC961205DNA*	34,600	25,600	14.50	11.50	1,200	7516826
	CSCF4860N6D*	G*VC81005C*B*	33,400	24,800	14.50	11.50	1,200	7516833
	CSCF4860N6D*	A*VC960804CNA*	34,600	25,600	14.50	11.50	1,190	7516824
	CSCF4860N6D*	G*VC80805C*B*	33,600	25,000	14.50	11.50	1,200	7516832
	CSCF4860N6D*	G*E81005C*B*	34,000	25,200	14.50	11.50	1,230	7516831
	CSCF4860N6D*	A*VM971205DNA*	34,600	25,600	14.50	11.50	1,200	7516829
CSCF4860N6D*	G*VC961205DNA*	34,600	25,600	14.50	11.50	1,200	7516836	
CSCF4860N6D*	G*VM970804CNA*	34,600	25,600	14.50	11.50	1,190	7516837	
CSCF4860N6D*	A*VC961005CNA*	34,600	25,600	14.50	11.50	1,175	7516825	
CSCF4860N6D*+EEP		34,600	25,600	14.00	11.50	1,200	7516790	
CSCF4860N6D*+EEP+TXV		34,600	25,600	14.00	11.50	1,200	7516791	
CSCF4860N6D*+TXV	A*VM970804CNA*	34,600	25,600	14.50	11.50	1,190	7516803	
CSCF4860N6D*+TXV	G*VC960403BNA*	34,200	25,400	14.50	11.50	1,200	7516811	
CSCF4860N6D*+TXV	A*VC960403BNA*	34,200	25,400	14.50	11.50	1,200	7516795	
CSCF4860N6D*+TXV	G*VM970603BNA*	34,400	25,400	14.50	11.50	1,250	7516817	
CSCF4860N6D*+TXV	A*VC960603BNA*	34,400	25,400	14.50	11.50	1,250	7516796	
CSCF4860N6D*+TXV	A*VC80805C*B*	33,600	25,000	14.50	12.00	1,200	7516793	

See Notes on Page 56.

OUTDOOR UNIT	INDOOR UNITS		COOLING RATINGS				CFM	AHRI #
	COILS/AIR HANDLERS	FURNACES	TOTAL ¹	SENS. ¹	SEER ²	EER ³		
GSX14 0361K* (cont.)	CSCF4860N6D*+TXV	G*VM971005CNA*	34,600	25,600	14.50	11.50	1,175	7516820
	CSCF4860N6D*+TXV	G*VM971205DNA*	34,600	25,600	14.50	12.00	1,200	7516821
	CSCF4860N6D*+TXV	G*VC80805C*B*	33,600	25,000	14.50	12.00	1,200	7516809
	CSCF4860N6D*+TXV	A*VM971205DNA*	34,600	25,600	14.50	12.00	1,200	7516805
	CSCF4860N6D*+TXV	A*VC961205DNA*	34,600	25,600	14.50	12.00	1,200	7516800
	CSCF4860N6D*+TXV	G*VC960603BNA*	34,400	25,400	14.50	11.50	1,250	7516812
	CSCF4860N6D*+TXV	G*VM970803BNA*	34,400	25,400	14.50	11.50	1,250	7516818
	CSCF4860N6D*+TXV	G*VC80604B*B*	33,600	25,000	14.50	11.50	1,220	7516808
	CSCF4860N6D*+TXV	A*VC80604B*B*	33,600	25,000	14.50	11.50	1,220	7516792
	CSCF4860N6D*+TXV	A*VC960803BNA*	34,400	25,400	14.50	11.50	1,250	7516797
	CSCF4860N6D*+TXV	G*VC81005C*B*	33,400	24,800	14.50	11.50	1,200	7516810
	CSCF4860N6D*+TXV	G*VC960803BNA*	34,400	25,400	14.50	11.50	1,250	7516813
	CSCF4860N6D*+TXV	A*VM971005CNA*	34,600	25,600	14.50	11.50	1,175	7516804
	CSCF4860N6D*+TXV	A*VC81005C*B*	33,400	24,800	14.50	11.50	1,200	7516794
	CSCF4860N6D*+TXV	G*VM970804CNA*	34,600	25,600	14.50	11.50	1,190	7516819
	CSCF4860N6D*+TXV	G*E80603B*B*	33,400	24,800	14.50	11.50	1,250	7516840
	CSCF4860N6D*+TXV	A*VM970603BNA*	34,400	25,400	14.50	11.50	1,250	7516801
	CSCF4860N6D*+TXV	G*VC960804CNA*	34,600	25,600	14.50	12.00	1,190	7516814
	CSCF4860N6D*+TXV	A*VM970803BNA*	34,400	25,400	14.50	11.50	1,250	7516802
	CSCF4860N6D*+TXV	A*VC960804CNA*	34,600	25,600	14.50	12.00	1,190	7516798
CSCF4860N6D*+TXV	G*E81005C*B*	34,000	25,200	14.50	12.00	1,230	7516807	
CSCF4860N6D*+TXV	A*VC961005CNA*	34,600	25,600	14.50	11.50	1,175	7516799	
CSCF4860N6D*+TXV	G*E80805C*B*	33,600	25,000	14.50	11.50	1,210	7516806	
CSCF4860N6D*+TXV	G*VC961005CNA*	34,600	25,600	14.50	11.50	1,175	7516815	
CSCF4860N6D*+TXV	G*VC961205DNA*	34,600	25,600	14.50	12.00	1,200	7516816	
GSX14 0371K*	ASPT36C14A*		34,200	25,800	14.50	12.50	1,210	7516841
	ASPT42D14A*		34,200	25,800	15.00	12.50	1,280	7516842
	AVPTC36C14A*		34,000	25,800	14.50	12.20	1,100	7516843
	AVPTC42D14A*		34,800	26,400	15.00	12.50	1,120	7516844
	AWUF37XX16B*+TXV		33,000	25,000	14.50	12.20	355	7516845
	CA*F3137*6A*	G*E80603B*B*	33,400	25,200	14.50	12.20	1,225	7520322
	CA*F3137*6A*		34,200	25,800	14.50	12.20	1,200	7516846
	CA*F3137*6A*+EEP		34,000	25,800	14.00	12.20	1,200	7516868
	CA*F3137*6A*+EEP+TXV		34,000	25,800	14.00	12.20	1,200	7516869
	CA*F3137*6A*+TXV		34,200	25,800	14.50	12.20	1,200	7516847
	CA*F3743*6D*	G*E81005C*B*	34,000	25,800	14.50	12.20	1,200	7516943
	CA*F3743*6D*	G*VM971205DNA*	34,600	26,200	15.00	12.50	1,200	7516953
	CA*F3743*6D*	A*VM971005CNA*	34,600	26,200	14.50	12.20	1,175	7516940
	CA*F3743*6D*	G*VC80805C*B*	33,600	25,400	14.50	12.20	1,200	7516946
	CA*F3743*6D*	G*EC961205DNA*	34,400	26,000	15.00	12.50	1,075	7516945
	CA*F3743*6D*	G*VM970804CNA*	34,600	26,200	14.50	12.20	1,190	7516951
	CA*F3743*6D*	A*VC80805C*B*	33,600	25,400	14.50	12.20	1,200	7516934
	CA*F3743*6D*	A*VC960804CNA*	34,600	26,200	14.50	12.20	1,190	7516936
	CA*F3743*6D*	A*VC961005CNA*	34,600	26,200	14.50	12.20	1,175	7516937
	CA*F3743*6D*	G*EC961004CNA*	34,600	26,200	14.50	12.20	1,250	7516944
	CA*F3743*6D*	G*VM971005CNA*	34,600	26,200	14.50	12.20	1,175	7516952
	CA*F3743*6D*	G*VC961205DNA*	34,600	26,200	15.00	12.50	1,200	7516950
	CA*F3743*6D*	G*VC81005C*B*	33,400	25,200	14.50	12.20	1,200	7516947
	CA*F3743*6D*	A*EC961205DNA*	34,400	26,000	15.00	12.50	1,075	7516933
CA*F3743*6D*	A*VC961205DNA*	34,600	26,200	15.00	12.50	1,200	7516938	
CA*F3743*6D*	G*VC961005CNA*	34,600	26,200	14.50	12.20	1,175	7516949	
CA*F3743*6D*	A*VC81005C*B*	33,400	25,200	14.50	12.20	1,200	7516935	
CA*F3743*6D*	A*EC961004CNA*	34,600	26,200	14.50	12.20	1,250	7516932	

See Notes on Page 56.

OUTDOOR UNIT	INDOOR UNITS		COOLING RATINGS				CFM	AHRI #
	COILS/AIR HANDLERS	FURNACES	TOTAL ¹	SENS. ¹	SEER ²	EER ³		
GSX14 0371K* (cont.)	CA*F3743*6D*	G*VC960804CNA*	34,600	26,200	14.50	12.20	1,190	7516948
	CA*F3743*6D*	A*VM970804CNA*	34,600	26,200	14.50	12.20	1,190	7516939
	CA*F3743*6D*	A*VM971205DNA*	34,600	26,200	15.00	12.50	1,200	7516941
	CA*F3743*6D*	G*E80805C*B*	33,600	25,400	14.50	12.20	1,210	7516942
	CA*F3743*6D*+EEP		34,000	25,800	14.00	12.20	1,200	7516891
	CA*F3743*6D*+EEP+TXV		34,000	25,800	14.50	12.20	1,200	7516892
	CA*F3743*6D*+MBVC1600**-1A*		34,600	26,200	14.50	12.20	1,200	7516893
	CA*F3743*6D*+MBVC1600**-1A*+TXV		34,600	26,200	14.50	12.20	1,200	7516894
	CA*F3743*6D*+MBVC2000**-1A*		34,600	26,200	15.00	12.50	1,200	7516895
	CA*F3743*6D*+MBVC2000**-1A*+TXV		34,600	26,200	15.00	12.50	1,200	7516896
	CA*F3743*6D*+TXV	G*VM971005CNA*	34,600	26,200	15.00	12.50	1,175	7516930
	CA*F3743*6D*+TXV	A*EC961004CNA*	34,600	26,200	15.00	12.50	1,250	7516897
	CA*F3743*6D*+TXV	G*VC961205DNA*	34,600	26,200	15.00	12.50	1,200	7516926
	CA*F3743*6D*+TXV	G*VC960803BNA*	34,400	26,000	14.50	12.20	1,250	7516923
	CA*F3743*6D*+TXV	G*VM971205DNA*	34,600	26,200	15.00	12.50	1,200	7516931
	CA*F3743*6D*+TXV	G*VC960603BNA*	34,400	26,000	14.50	12.20	1,250	7516922
	CA*F3743*6D*+TXV	G*VM970603BNA*	34,200	25,800	14.50	12.20	1,250	7516927
	CA*F3743*6D*+TXV	A*VC961005CNA*	34,600	26,200	15.00	12.50	1,175	7516906
	CA*F3743*6D*+TXV	A*EC961205DNA*	34,400	26,000	15.00	12.50	1,075	7516898
	CA*F3743*6D*+TXV	A*VC961205DNA*	34,600	26,200	15.00	12.50	1,200	7516907
	CA*F3743*6D*+TXV	G*E81005C*B*	34,000	25,800	15.00	12.50	1,200	7516915
	CA*F3743*6D*+TXV	A*VM971205DNA*	34,600	26,200	15.00	12.50	1,200	7516912
	CA*F3743*6D*+TXV	A*VC80805C*B*	33,600	25,400	15.00	12.50	1,200	7516900
	CA*F3743*6D*+TXV	G*E80805C*B*	33,600	25,400	15.00	12.50	1,210	7516914
	CA*F3743*6D*+TXV	A*VC80604B*B*	33,600	25,400	14.50	12.20	1,220	7516899
	CA*F3743*6D*+TXV	A*VC960804CNA*	34,600	26,200	15.00	12.50	1,190	7516905
	CA*F3743*6D*+TXV	A*VC81005C*B*	33,400	25,200	15.00	12.50	1,200	7516901
	CA*F3743*6D*+TXV	G*VC960403BNA*	34,000	25,800	14.50	12.20	1,200	7516921
	CA*F3743*6D*+TXV	A*VC960603BNA*	34,400	26,000	14.50	12.20	1,250	7516903
	CA*F3743*6D*+TXV	A*VM970803BNA*	34,400	26,000	14.50	12.20	1,250	7516909
	CA*F3743*6D*+TXV	A*VM970804CNA*	34,600	26,200	15.00	12.50	1,190	7516910
	CA*F3743*6D*+TXV	G*VC81005C*B*	33,400	25,200	15.00	12.50	1,200	7516920
	CA*F3743*6D*+TXV	G*E80603B*B*	33,400	25,200	14.50	12.20	1,225	7516913
	CA*F3743*6D*+TXV	G*VM970804CNA*	34,600	26,200	15.00	12.50	1,190	7516929
	CA*F3743*6D*+TXV	G*VC80805C*B*	33,600	25,400	15.00	12.50	1,200	7516919
	CA*F3743*6D*+TXV	G*VC80604B*B*	33,600	25,400	14.50	12.20	1,220	7516918
	CA*F3743*6D*+TXV	A*VM971005CNA*	34,600	26,200	15.00	12.50	1,175	7516911
	CA*F3743*6D*+TXV	G*EC961205DNA*	34,400	26,000	15.00	12.50	1,075	7516917
	CA*F3743*6D*+TXV	G*EC961004CNA*	34,600	26,200	15.00	12.50	1,250	7516916
	CA*F3743*6D*+TXV	A*VC960803BNA*	34,400	26,000	14.50	12.20	1,250	7516904
	CA*F3743*6D*+TXV	A*VC960403BNA*	34,000	25,800	14.50	12.20	1,200	7516902
	CA*F3743*6D*+TXV	G*VM970803BNA*	34,400	26,000	14.50	12.20	1,250	7516928
	CA*F3743*6D*+TXV	A*VM970603BNA*	34,200	25,800	14.50	12.20	1,250	7516908
	CA*F3743*6D*+TXV	G*VC960804CNA*	34,600	26,200	15.00	12.50	1,190	7516924
	CA*F3743*6D*+TXV	G*VC961005CNA*	34,600	26,200	15.00	12.50	1,175	7516925
	CAPT3743*4A*	G*VC961205DNA*	34,400	26,000	15.00	12.50	1,200	7516985
	CAPT3743*4A*	G*EC961004CNA*	34,600	26,200	14.50	12.20	1,250	7516975
CAPT3743*4A*	G*VC960803BNA*	34,200	25,800	14.50	12.20	1,250	7516982	
CAPT3743*4A*	A*VM970804CNA*	34,600	26,200	15.00	12.20	1,190	7516970	
CAPT3743*4A*	G*EC961205DNA*	34,400	26,000	15.00	12.50	1,075	7516976	
CAPT3743*4A*	G*VC960603BNA*	34,200	25,800	14.50	12.20	1,250	7516981	
CAPT3743*4A*	A*VM971005CNA*	34,600	26,200	15.00	12.20	1,175	7516971	
CAPT3743*4A*	G*VC80805C*B*	33,600	25,400	15.00	12.20	1,200	7516978	

See Notes on Page 56.

OUTDOOR UNIT	INDOOR UNITS		COOLING RATINGS				CFM	AHRI #
	COILS/AIR HANDLERS	FURNACES	TOTAL ¹	SENS. ¹	SEER ²	EER ³		
GSX14 0371K* (cont.)	CAPT3743*4A*	G*VC960804CNA*	34,600	26,200	15.00	12.20	1,190	7516983
	CAPT3743*4A*	A*VM970603BNA*	34,200	25,800	14.50	12.20	1,250	7516968
	CAPT3743*4A*	G*E81005C*B*	34,000	25,800	14.50	12.20	1,200	7516974
	CAPT3743*4A*	A*EC961205DNA*	34,400	26,000	15.00	12.50	1,075	7516958
	CAPT3743*4A*	G*VC80604B*B*	33,600	25,400	14.50	12.20	1,220	7516977
	CAPT3743*4A*	G*VM970804CNA*	34,600	26,200	15.00	12.20	1,190	7516988
	CAPT3743*4A*	A*VC80805C*B*	33,600	25,400	15.00	12.20	1,200	7516960
	CAPT3743*4A*	A*VC961005CNA*	34,600	26,200	15.00	12.20	1,175	7516966
	CAPT3743*4A*	G*VC960403BNA*	34,000	25,800	14.50	12.20	1,200	7516980
	CAPT3743*4A*	A*VC960603BNA*	34,200	25,800	14.50	12.20	1,250	7516963
	CAPT3743*4A*	A*VC960803BNA*	34,200	25,800	14.50	12.20	1,250	7516964
	CAPT3743*4A*	A*VC960403BNA*	34,000	25,800	14.50	12.20	1,200	7516962
	CAPT3743*4A*	G*E80805C*B*	33,600	25,400	14.50	12.20	1,210	7516973
	CAPT3743*4A*	A*VC80604B*B*	33,600	25,400	14.50	12.20	1,220	7516959
	CAPT3743*4A*	A*VM971205DNA*	34,400	26,000	15.00	12.50	1,200	7516972
	CAPT3743*4A*	G*VC961005CNA*	34,600	26,200	15.00	12.20	1,175	7516984
	CAPT3743*4A*	A*EC961004CNA*	34,600	26,200	14.50	12.20	1,250	7516957
	CAPT3743*4A*	A*VM970803BNA*	34,200	25,800	14.50	12.20	1,250	7516969
	CAPT3743*4A*	G*VM971205DNA*	34,400	26,000	15.00	12.50	1,200	7516990
	CAPT3743*4A*	G*VM971005CNA*	34,600	26,200	15.00	12.20	1,175	7516989
	CAPT3743*4A*	A*VC961205DNA*	34,400	26,000	15.00	12.50	1,200	7516967
	CAPT3743*4A*	G*VM970603BNA*	34,200	25,800	14.50	12.20	1,250	7516986
	CAPT3743*4A*	A*VC960804CNA*	34,600	26,200	15.00	12.20	1,190	7516965
	CAPT3743*4A*	G*VM970803BNA*	34,200	25,800	14.50	12.20	1,250	7516987
	CAPT3743*4A*	G*VC81005C*B*	33,400	25,200	15.00	12.20	1,200	7516979
	CAPT3743*4A*	A*VC81005C*B*	33,400	25,200	15.00	12.20	1,200	7516961
	CAPT3743*4A*+EEP		34,000	25,800	14.50	12.20	1,200	7516954
	CAPT3743*4A*+MBVC1600**-1A*		34,200	25,800	14.50	12.20	1,200	7516955
	CAPT3743*4A*+MBVC1600**-1A*+TXV		34,200	25,800	14.50	12.20	1,200	7519538
	CAPT3743*4A*+MBVC2000**-1A*		34,200	25,800	14.50	12.20	1,200	7516956
	CAPT3743*4A*+MBVC2000**-1A*+TXV		34,200	25,800	14.50	12.20	1,200	7519539
	CHPF3642C6C*	G*E80805C*B*	33,600	25,400	14.50	12.20	1,210	7516998
	CHPF3642C6C*	G*E81005C*B*	34,000	25,800	14.50	12.20	1,200	7516999
	CHPF3642C6C*+EEP		34,000	25,800	14.00	12.20	1,150	7516991
	CHPF3642C6C*+EEP+TXV		34,000	25,800	14.00	12.20	1,150	7516992
	CHPF3642C6C*+MBVC1600**-1A*		34,000	25,800	14.50	12.20	1,200	7516993
	CHPF3642C6C*+MBVC1600**-1A*+TXV		34,000	25,800	15.00	12.50	1,200	7516994
	CHPF3642C6C*+TXV	G*E81005C*B*	34,000	25,800	15.00	12.50	1,200	7516997
	CHPF3642C6C*+TXV	G*E80805C*B*	33,600	25,400	15.00	12.50	1,210	7516996
	CHPF3642C6C*+TXV	G*E80603B*B*	33,400	25,200	14.50	12.20	1,225	7516995
	CHPF3743C6B*+MBVC1600**-1A*		34,600	26,200	14.50	12.20	1,200	7517012
	CHPF3743C6B*+MBVC1600**-1A*+TXV		34,600	26,200	15.00	12.50	1,200	7517013
	CHPF3743C6B*+TXV	G*VM970803BNA*	34,400	26,000	14.50	12.20	1,250	7517011
	CHPF3743C6B*+TXV	A*VM970803BNA*	34,400	26,000	14.50	12.20	1,250	7517005
	CHPF3743C6B*+TXV	A*VC80604B*B*	33,600	25,400	14.50	12.20	1,220	7517000
	CHPF3743C6B*+TXV	G*VC80604B*B*	33,600	25,400	14.50	12.20	1,220	7517006
	CHPF3743C6B*+TXV	A*VC960603BNA*	34,400	26,000	14.50	12.20	1,250	7517002
	CHPF3743C6B*+TXV	G*VC960603BNA*	34,400	26,000	14.50	12.20	1,250	7517008
CHPF3743C6B*+TXV	A*VC960403BNA*	34,200	25,800	14.50	12.20	1,200	7517001	
CHPF3743C6B*+TXV	G*VC960403BNA*	34,200	25,800	14.50	12.20	1,200	7517007	
CHPF3743C6B*+TXV	G*VC960803BNA*	34,400	26,000	14.50	12.20	1,250	7517009	
CHPF3743C6B*+TXV	A*VC960803BNA*	34,400	26,000	14.50	12.20	1,250	7517003	
CHPF3743C6B*+TXV	G*VM970603BNA*	34,400	26,000	14.50	12.20	1,250	7517010	

See Notes on Page 56.

OUTDOOR UNIT	INDOOR UNITS		COOLING RATINGS				CFM	AHRI #
	COILS/AIR HANDLERS	FURNACES	TOTAL ¹	SENS. ¹	SEER ²	EER ³		
GSX14 0371K* (cont.)	CHPF3743C6B*+TXV	A*VM970603BNA*	34,400	26,000	14.50	12.20	1,250	7517004
	CHPF3743D6B*	A*EC961004CNA*	34,600	26,200	14.50	12.20	1,250	7517038
	CHPF3743D6B*	G*VM971005CNA*	34,600	26,200	14.50	12.20	1,175	7517056
	CHPF3743D6B*	A*VC960804CNA*	34,600	26,200	14.50	12.20	1,190	7517042
	CHPF3743D6B*	A*VM971005CNA*	34,600	26,200	14.50	12.20	1,175	7517046
	CHPF3743D6B*	G*VC961005CNA*	34,600	26,200	14.50	12.20	1,175	7517053
	CHPF3743D6B*	A*VM971205DNA*	34,600	26,200	15.00	12.50	1,200	7517047
	CHPF3743D6B*	G*VM971205DNA*	34,600	26,200	15.00	12.50	1,200	7517057
	CHPF3743D6B*	G*EC961205DNA*	34,200	25,800	15.00	12.50	1,075	7517049
	CHPF3743D6B*		34,600	26,200	14.50	12.20	1,150	7517014
	CHPF3743D6B*	G*VC960804CNA*	34,600	26,200	14.50	12.20	1,190	7517052
	CHPF3743D6B*	A*VM970804CNA*	34,600	26,200	14.50	12.20	1,190	7517045
	CHPF3743D6B*	A*VC80805C*B*	33,600	25,400	14.50	12.20	1,200	7517040
	CHPF3743D6B*	A*VC81005C*B*	33,400	25,200	14.50	12.20	1,200	7517041
	CHPF3743D6B*	G*VC961205DNA*	34,600	26,200	15.00	12.50	1,200	7517054
	CHPF3743D6B*	G*VC80805C*B*	33,600	25,400	14.50	12.20	1,200	7517050
	CHPF3743D6B*	A*VC961205DNA*	34,600	26,200	15.00	12.50	1,200	7517044
	CHPF3743D6B*	G*VC81005C*B*	33,400	25,200	14.50	12.20	1,200	7517051
	CHPF3743D6B*	G*VM970804CNA*	34,600	26,200	14.50	12.20	1,190	7517055
	CHPF3743D6B*	A*EC961205DNA*	34,200	25,800	15.00	12.50	1,075	7517039
	CHPF3743D6B*	G*EC961004CNA*	34,600	26,200	14.50	12.20	1,250	7517048
	CHPF3743D6B*	A*VC961005CNA*	34,600	26,200	14.50	12.20	1,175	7517043
	CHPF3743D6B*+EEP		34,600	26,200	14.50	12.20	1,150	7517015
	CHPF3743D6B*+EEP+TXV		34,600	26,200	15.00	12.50	1,150	7517016
	CHPF3743D6B*+TXV	G*VC960804CNA*	34,600	26,200	15.00	12.50	1,190	7517032
	CHPF3743D6B*+TXV	G*VM971005CNA*	34,600	26,200	15.00	12.50	1,175	7517036
	CHPF3743D6B*+TXV	A*VC80805C*B*	33,600	25,400	15.00	12.50	1,200	7517020
	CHPF3743D6B*+TXV	G*VM970804CNA*	34,600	26,200	15.00	12.50	1,190	7517035
	CHPF3743D6B*+TXV	G*VC80805C*B*	33,600	25,400	15.00	12.50	1,200	7517030
	CHPF3743D6B*+TXV	G*EC961004CNA*	34,600	26,200	15.00	12.50	1,250	7517028
	CHPF3743D6B*+TXV	G*EC961205DNA*	34,200	25,800	15.00	12.50	1,075	7517029
	CHPF3743D6B*+TXV	G*VC961005CNA*	34,600	26,200	15.00	12.50	1,175	7517033
	CHPF3743D6B*+TXV		34,600	26,200	15.00	12.50	1,150	7517017
	CHPF3743D6B*+TXV	G*VM971205DNA*	34,600	26,200	15.00	12.50	1,200	7517037
	CHPF3743D6B*+TXV	A*VM971205DNA*	34,600	26,200	15.00	12.50	1,200	7517027
	CHPF3743D6B*+TXV	A*VC960804CNA*	34,600	26,200	15.00	12.50	1,190	7517022
	CHPF3743D6B*+TXV	G*VC961205DNA*	34,600	26,200	15.00	12.50	1,200	7517034
	CHPF3743D6B*+TXV	A*VM970804CNA*	34,600	26,200	15.00	12.50	1,190	7517025
	CHPF3743D6B*+TXV	G*VC81005C*B*	33,400	25,200	15.00	12.50	1,200	7517031
	CHPF3743D6B*+TXV	A*EC961205DNA*	34,200	25,800	15.00	12.50	1,075	7517019
	CHPF3743D6B*+TXV	A*VC81005C*B*	33,400	25,200	15.00	12.50	1,200	7517021
	CHPF3743D6B*+TXV	A*VM971005CNA*	34,600	26,200	15.00	12.50	1,175	7517026
	CHPF3743D6B*+TXV	A*VC961205DNA*	34,600	26,200	15.00	12.50	1,200	7517024
	CHPF3743D6B*+TXV	A*EC961004CNA*	34,600	26,200	15.00	12.50	1,250	7517018
	CHPF3743D6B*+TXV	A*VC961005CNA*	34,600	26,200	15.00	12.50	1,175	7517023
	CSCF4860N6D*	G*E81005C*B*	34,000	25,800	14.50	12.20	1,200	7517106
	CSCF4860N6D*	G*VC81005C*B*	33,400	25,200	14.50	12.20	1,200	7517110
	CSCF4860N6D*	A*EC961205DNA*	34,200	25,800	15.00	12.50	1,075	7517096
	CSCF4860N6D*	G*VC80805C*B*	33,600	25,400	14.50	12.20	1,200	7517109
	CSCF4860N6D*	G*VM971205DNA*	34,600	26,200	15.00	12.50	1,200	7517116
CSCF4860N6D*	A*VC80805C*B*	33,600	25,400	14.50	12.20	1,200	7517097	
CSCF4860N6D*	A*VC960804CNA*	34,600	26,200	14.50	12.20	1,190	7517099	
CSCF4860N6D*	G*EC961205DNA*	34,200	25,800	15.00	12.50	1,075	7517108	
CSCF4860N6D*	G*VM971005CNA*	34,600	26,200	14.50	12.20	1,175	7517115	
CSCF4860N6D*	G*VC961005CNA*	34,600	26,200	14.50	12.20	1,175	7517112	
CSCF4860N6D*	G*EC961004CNA*	34,600	26,200	14.50	12.20	1,250	7517107	
CSCF4860N6D*	A*VM970804CNA*	34,600	26,200	14.50	12.20	1,190	7517102	

See Notes on Page 56.

OUTDOOR UNIT	INDOOR UNITS		COOLING RATINGS				CFM	AHRI #
	COILS/AIR HANDLERS	FURNACES	TOTAL ¹	SENS. ¹	SEER ²	EER ³		
GSX14 0371K* (cont.)	CSCF4860N6D*	G*VC960804CNA*	34,600	26,200	14.50	12.20	1,190	7517111
	CSCF4860N6D*	A*VC961205DNA*	34,600	26,200	15.00	12.50	1,200	7517101
	CSCF4860N6D*	A*EC961004CNA*	34,600	26,200	14.50	12.20	1,250	7517095
	CSCF4860N6D*	A*VM971005CNA*	34,600	26,200	14.50	12.20	1,175	7517103
	CSCF4860N6D*	A*VC81005C*B*	33,400	25,200	14.50	12.20	1,200	7517098
	CSCF4860N6D*	G*VC961205DNA*	34,600	26,200	15.00	12.50	1,200	7517113
	CSCF4860N6D*	A*VM971205DNA*	34,600	26,200	15.00	12.50	1,200	7517104
	CSCF4860N6D*	A*VC961005CNA*	34,600	26,200	14.50	12.20	1,175	7517100
	CSCF4860N6D*	G*E80805C*B*	33,600	25,400	14.50	12.20	1,210	7517105
	CSCF4860N6D*	G*VM970804CNA*	34,600	26,200	14.50	12.20	1,190	7517114
	CSCF4860N6D*+EEP		34,600	26,200	14.00	12.20	1,200	7517058
	CSCF4860N6D*+EEP+TXV		34,600	26,200	14.50	12.20	1,200	7517059
	CSCF4860N6D*+TXV	A*EC961205DNA*	34,200	25,800	15.00	12.50	1,075	7517061
	CSCF4860N6D*+TXV	A*VC81005C*B*	33,400	25,200	15.00	12.50	1,200	7517064
	CSCF4860N6D*+TXV	G*VM970804CNA*	34,600	26,200	15.00	12.50	1,190	7517092
	CSCF4860N6D*+TXV	G*VC960403BNA*	34,200	25,800	14.50	12.20	1,200	7517084
	CSCF4860N6D*+TXV	G*VC81005C*B*	33,400	25,200	15.00	12.50	1,200	7517083
	CSCF4860N6D*+TXV	A*VC961005CNA*	34,600	26,200	15.00	12.50	1,175	7517069
	CSCF4860N6D*+TXV	A*VC80805C*B*	33,600	25,400	15.00	12.50	1,200	7517063
	CSCF4860N6D*+TXV	A*VC961205DNA*	34,600	26,200	15.00	12.50	1,200	7517070
	CSCF4860N6D*+TXV	G*E81005C*B*	34,000	25,800	15.00	12.50	1,200	7517078
	CSCF4860N6D*+TXV	G*VC960804CNA*	34,600	26,200	15.00	12.50	1,190	7517087
	CSCF4860N6D*+TXV	G*VC961005CNA*	34,600	26,200	15.00	12.50	1,175	7517088
	CSCF4860N6D*+TXV	A*EC961004CNA*	34,600	26,200	15.00	12.50	1,250	7517060
	CSCF4860N6D*+TXV	G*VC961205DNA*	34,600	26,200	15.00	12.50	1,200	7517089
	CSCF4860N6D*+TXV	G*EC961004CNA*	34,600	26,200	15.00	12.50	1,250	7517079
	CSCF4860N6D*+TXV	A*VC960804CNA*	34,600	26,200	15.00	12.50	1,190	7517068
	CSCF4860N6D*+TXV	A*VM971205DNA*	34,600	26,200	15.00	12.50	1,200	7517075
	CSCF4860N6D*+TXV	G*VC960603BNA*	34,400	26,000	14.50	12.20	1,250	7517085
	CSCF4860N6D*+TXV	G*E80603B*B*	33,400	25,200	14.50	12.20	1,225	7517076
	CSCF4860N6D*+TXV	G*VC80805C*B*	33,600	25,400	15.00	12.50	1,200	7517082
	CSCF4860N6D*+TXV	G*VC960803BNA*	34,400	26,000	14.50	12.20	1,250	7517086
	CSCF4860N6D*+TXV	G*VM971005CNA*	34,600	26,200	15.00	12.50	1,175	7517093
	CSCF4860N6D*+TXV	G*VM971205DNA*	34,600	26,200	15.00	12.50	1,200	7517094
	CSCF4860N6D*+TXV	G*VM970603BNA*	34,400	26,000	14.50	12.20	1,250	7517090
	CSCF4860N6D*+TXV	G*VC80604B*B*	33,600	25,400	14.50	12.20	1,220	7517081
	CSCF4860N6D*+TXV	A*VC960603BNA*	34,400	26,000	14.50	12.20	1,250	7517066
	CSCF4860N6D*+TXV	A*VC960803BNA*	34,400	26,000	14.50	12.20	1,250	7517067
	CSCF4860N6D*+TXV	G*E80805C*B*	33,600	25,400	15.00	12.50	1,210	7517077
	CSCF4860N6D*+TXV	A*VC80604B*B*	33,600	25,400	14.50	12.20	1,220	7517062
CSCF4860N6D*+TXV	A*VM971005CNA*	34,600	26,200	15.00	12.50	1,175	7517074	
CSCF4860N6D*+TXV	A*VC960403BNA*	34,200	25,800	14.50	12.20	1,200	7517065	
CSCF4860N6D*+TXV	A*VM970804CNA*	34,600	26,200	15.00	12.50	1,190	7517073	
CSCF4860N6D*+TXV	A*VM970603BNA*	34,400	26,000	14.50	12.20	1,250	7517071	
CSCF4860N6D*+TXV	G*VM970803BNA*	34,400	26,000	14.50	12.20	1,250	7517091	
CSCF4860N6D*+TXV	G*EC961205DNA*	34,200	25,800	15.00	12.50	1,075	7517080	
CSCF4860N6D*+TXV	A*VM970803BNA*	34,400	26,000	14.50	12.20	1,250	7517072	

¹ BTU/h

² Seasonal Energy Efficiency Ratio; Certified per AHRI 210/240 @ 80°F/ 67°F/ 95°F

³ Energy Efficiency Ratio @ 80°F/ 67°F/ 95°F

NOTES

- Always check the S&R plate for electrical data on the unit being installed.
- When matching the outdoor unit to the indoor unit, use the piston supplied with the outdoor unit or that specified on the piston kit chart supplied with the indoor unit.
- EEP - Order from Service Dept. Part No. B13707-38 or new Solid State Board B13707-35S. Part No. B13707-38 is not interchangeable with B13707-35S. The Goodman Gas Furnace contains the EEP cooling time delay

OUTDOOR UNIT	INDOOR UNITS		COOLING RATINGS				CFM	AHRI #
	COILS/AIR HANDLERS	FURNACES	TOTAL ¹	SENS. ¹	SEER ²	EER ³		
GSX14 0421K*	ASPT48D14A*		38,000	30,000	15.00	12.50	1,385	7517117
	ASPT60D14A*		38,000	30,000	15.00	12.50	1,385	7517118
	AVPTC48D14A*		38,000	30,000	15.00	12.50	1,310	7517119
	CA*F4860*6D*	A*VC961005CNA*	38,000	30,000	14.00	11.50	1,300	7517148
	CA*F4860*6D*	A*EC961004CNA*	38,000	30,000	14.00	11.50	1,275	7517143
	CA*F4860*6D*	G*EC961205DNA*	38,000	30,000	14.00	11.50	1,400	7517155
	CA*F4860*6D*	G*VM971005CNA*	38,000	30,000	14.00	11.50	1,300	7517160
	CA*F4860*6D*	G*VC961205DNA*	38,000	30,000	14.00	11.50	1,425	7520335
	CA*F4860*6D*	A*VM971005CNA*	38,000	30,000	14.00	11.50	1,300	7517149
	CA*F4860*6D*	G*VM970804CNA*	38,000	30,000	14.00	11.50	1,425	7520336
	CA*F4860*6D*	A*VM971205DNA*	38,000	30,000	14.00	11.50	1,300	7517150
	CA*F4860*6D*	A*VC81005C*B*	38,000	30,000	14.00	11.50	1,370	7517146
	CA*F4860*6D*	G*EC961004CNA*	38,000	30,000	14.00	11.50	1,275	7517154
	CA*F4860*6D*	G*VC80805C*B*	38,000	30,000	14.00	11.50	1,400	7517156
	CA*F4860*6D*	A*VC80805C*B*	38,000	30,000	14.00	11.50	1,400	7517145
	CA*F4860*6D*	G*VM971205DNA*	38,000	30,000	14.00	11.50	1,300	7517161
	CA*F4860*6D*	A*VM970804CNA*	38,000	30,000	14.00	11.50	1,425	7520334
	CA*F4860*6D*	G*E80805C*B*	38,000	30,000	14.00	11.50	1,425	7517151
	CA*F4860*6D*	A*VC960804CNA*	38,000	30,000	14.00	11.50	1,385	7517147
	CA*F4860*6D*	G*VC81005C*B*	38,000	30,000	14.00	11.50	1,370	7517157
	CA*F4860*6D*	A*VC961205DNA*	38,000	30,000	14.00	11.50	1,425	7520333
	CA*F4860*6D*	G*VC960804CNA*	38,000	30,000	14.00	11.50	1,385	7517158
	CA*F4860*6D*	G*E80805D*A*	38,000	30,000	14.00	11.50	1,425	7517152
	CA*F4860*6D*	G*VC961005CNA*	38,000	30,000	14.00	11.50	1,300	7517159
	CA*F4860*6D*	G*E81005C*B*	38,000	30,000	14.00	11.50	1,425	7517153
	CA*F4860*6D*	A*EC961205DNA*	38,000	30,000	14.00	11.50	1,400	7517144
	CA*F4860*6D*+EHP		38,000	30,000	14.00	11.50	1,400	7517120
	CA*F4860*6D*+EHP+TXV		38,000	30,000	14.00	11.50	1,400	7517121
	CA*F4860*6D*+MBVC1600**-1A*		38,000	30,000	14.50	11.50	1,300	7517122
	CA*F4860*6D*+MBVC2000**-1A*		38,000	30,000	14.50	11.50	1,300	7517123
	CA*F4860*6D*+TXV	G*VC961205DNA*	38,000	30,000	14.50	11.50	1,425	7520331
	CA*F4860*6D*+TXV	G*VC80805C*B*	38,000	30,000	14.50	11.50	1,400	7517137
	CA*F4860*6D*+TXV	G*VC961005CNA*	38,000	30,000	14.50	11.50	1,300	7517140
	CA*F4860*6D*+TXV	G*VM971205DNA*	38,000	30,000	14.50	11.50	1,300	7517142
	CA*F4860*6D*+TXV	A*VC80805C*B*	38,000	30,000	14.50	11.50	1,400	7517126
	CA*F4860*6D*+TXV	G*EC961004CNA*	38,000	30,000	14.50	11.50	1,275	7517135
	CA*F4860*6D*+TXV	A*VM971205DNA*	38,000	30,000	14.50	11.50	1,300	7517131
	CA*F4860*6D*+TXV	A*VC961005CNA*	38,000	30,000	14.50	11.50	1,300	7517129
	CA*F4860*6D*+TXV	A*VC961205DNA*	38,000	30,000	14.50	11.50	1,425	7520329
	CA*F4860*6D*+TXV	G*EC961205DNA*	38,000	30,000	14.50	11.50	1,400	7517136
	CA*F4860*6D*+TXV	G*E80805D*A*	38,000	30,000	14.50	11.50	1,425	7517133
	CA*F4860*6D*+TXV	G*VM971005CNA*	38,000	30,000	14.50	11.50	1,300	7517141
	CA*F4860*6D*+TXV	G*VM970804CNA*	38,000	30,000	14.50	11.50	1,425	7520332
	CA*F4860*6D*+TXV	G*E80805C*B*	38,000	30,000	14.50	11.50	1,425	7517132
	CA*F4860*6D*+TXV	A*EC961205DNA*	38,000	30,000	14.50	11.50	1,400	7517125
	CA*F4860*6D*+TXV	A*VC960804CNA*	38,000	30,000	14.50	11.50	1,385	7517128
	CA*F4860*6D*+TXV	G*VC81005C*B*	38,000	30,000	14.50	11.50	1,370	7517138
CA*F4860*6D*+TXV	A*EC961004CNA*	38,000	30,000	14.50	11.50	1,275	7517124	
CA*F4860*6D*+TXV	A*VM970804CNA*	38,000	30,000	14.50	11.50	1,425	7520330	
CA*F4860*6D*+TXV	G*E81005C*B*	38,000	30,000	14.50	11.50	1,425	7517134	
CA*F4860*6D*+TXV	A*VM971005CNA*	38,000	30,000	14.50	11.50	1,300	7517130	
CA*F4860*6D*+TXV	G*VC960804CNA*	38,000	30,000	14.50	11.50	1,385	7517139	
CA*F4860*6D*+TXV	A*VC81005C*B*	38,000	30,000	14.50	11.50	1,370	7517127	

See Notes on Page 56.

OUTDOOR UNIT	INDOOR UNITS		COOLING RATINGS				CFM	AHRI #
	COILS/AIR HANDLERS	FURNACES	TOTAL ¹	SENS. ¹	SEER ²	EER ³		
GSX14 0421K* (cont.)	CA*F4961*6D*	G*EC961205DNA*	39,000	30,800	14.50	12.20	1,400	7517203
	CA*F4961*6D*	G*E81005C*B*	39,000	30,800	14.50	12.20	1,425	7517201
	CA*F4961*6D*	G*VM971205DNA*	39,000	30,800	14.50	12.20	1,300	7517211
	CA*F4961*6D*	G*VC80805C*B*	39,000	30,800	14.50	12.20	1,400	7517204
	CA*F4961*6D*	A*VC960804CNA*	39,000	30,800	14.50	12.20	1,385	7517193
	CA*F4961*6D*	A*VC961005CNA*	39,000	30,800	14.50	12.20	1,300	7517194
	CA*F4961*6D*	G*VM970804CNA*	39,000	30,800	14.50	12.20	1,430	7517209
	CA*F4961*6D*	A*VC961205DNA*	39,000	30,800	14.50	12.20	1,450	7517195
	CA*F4961*6D*	G*E80805D*A*	39,000	30,800	14.50	12.20	1,425	7517200
	CA*F4961*6D*	G*VM971005CNA*	39,000	30,800	14.50	12.20	1,300	7517210
	CA*F4961*6D*	A*EC961004CNA*	39,000	30,800	14.50	12.20	1,275	7517189
	CA*F4961*6D*	A*VC80805C*B*	39,000	30,800	14.50	12.20	1,400	7517191
	CA*F4961*6D*	A*VM970804CNA*	39,000	30,800	14.50	12.20	1,430	7517196
	CA*F4961*6D*	G*VC960804CNA*	39,000	30,800	14.50	12.20	1,385	7517206
	CA*F4961*6D*	A*EC961205DNA*	39,000	30,800	14.50	12.20	1,400	7517190
	CA*F4961*6D*	A*VM971005CNA*	39,000	30,800	14.50	12.20	1,300	7517197
	CA*F4961*6D*	A*VC81005C*B*	39,000	30,800	14.50	12.20	1,370	7517192
	CA*F4961*6D*	G*E80805C*B*	39,000	30,800	14.50	12.20	1,425	7517199
	CA*F4961*6D*	G*VC81005C*B*	39,000	30,800	14.50	12.20	1,370	7517205
	CA*F4961*6D*	A*VM971205DNA*	39,000	30,800	14.50	12.20	1,300	7517198
	CA*F4961*6D*	G*EC961004CNA*	39,000	30,800	14.50	12.20	1,275	7517202
	CA*F4961*6D*	G*VC961005CNA*	39,000	30,800	14.50	12.20	1,300	7517207
	CA*F4961*6D*	G*VC961205DNA*	39,000	30,800	14.50	12.20	1,450	7517208
	CA*F4961*6D*+EEP		39,000	30,800	14.00	12.20	1,400	7517162
	CA*F4961*6D*+EEP+TXV		39,000	30,800	14.00	12.20	1,400	7517163
	CA*F4961*6D*+MBVC1600**-1A*		39,000	30,800	14.50	12.20	1,300	7517164
	CA*F4961*6D*+MBVC2000**-1A*		39,000	30,800	14.50	12.20	1,300	7517165
	CA*F4961*6D*+TXV	G*VC961205DNA*	39,000	30,800	14.50	12.20	1,450	7517185
	CA*F4961*6D*+TXV	A*VC81005C*B*	39,000	30,800	14.50	12.20	1,370	7517169
	CA*F4961*6D*+TXV	G*VC81005C*B*	39,000	30,800	14.50	12.20	1,370	7517182
	CA*F4961*6D*+TXV	G*E80805C*B*	39,000	30,800	14.50	12.20	1,425	7517176
	CA*F4961*6D*+TXV	A*VC961205DNA*	39,000	30,800	14.50	12.20	1,450	7517172
	CA*F4961*6D*+TXV	G*EC961004CNA*	39,000	30,800	14.50	12.20	1,275	7517179
	CA*F4961*6D*+TXV	A*VC961005CNA*	39,000	30,800	14.50	12.20	1,300	7517171
	CA*F4961*6D*+TXV	G*VC960804CNA*	39,000	30,800	14.50	12.20	1,385	7517183
	CA*F4961*6D*+TXV	G*VM971205DNA*	39,000	30,800	14.50	12.20	1,300	7517188
	CA*F4961*6D*+TXV	G*VM971005CNA*	39,000	30,800	14.50	12.20	1,300	7517187
	CA*F4961*6D*+TXV	A*EC961205DNA*	39,000	30,800	14.50	12.20	1,400	7517167
	CA*F4961*6D*+TXV	A*VM971205DNA*	39,000	30,800	14.50	12.20	1,300	7517175
	CA*F4961*6D*+TXV	G*E81005C*B*	39,000	30,800	14.50	12.20	1,425	7517178
	CA*F4961*6D*+TXV	G*VC80805C*B*	39,000	30,800	14.50	12.20	1,400	7517181
	CA*F4961*6D*+TXV	A*VC960804CNA*	39,000	30,800	14.50	12.20	1,385	7517170
	CA*F4961*6D*+TXV	A*EC961004CNA*	39,000	30,800	14.50	12.20	1,275	7517166
	CA*F4961*6D*+TXV	G*VM970804CNA*	39,000	30,800	14.50	12.20	1,430	7517186
	CA*F4961*6D*+TXV	A*VC80805C*B*	39,000	30,800	14.50	12.20	1,400	7517168
CA*F4961*6D*+TXV	G*EC961205DNA*	39,000	30,800	14.50	12.20	1,400	7517180	
CA*F4961*6D*+TXV	G*VC961005CNA*	39,000	30,800	14.50	12.20	1,300	7517184	
CA*F4961*6D*+TXV	G*E80805D*A*	39,000	30,800	14.50	12.20	1,425	7517177	
CA*F4961*6D*+TXV	A*VM970804CNA*	39,000	30,800	14.50	12.20	1,430	7517173	
CA*F4961*6D*+TXV	A*VM971005CNA*	39,000	30,800	14.50	12.20	1,300	7517174	
CAPT4961*4A*	G*VC961005CNA*	39,000	30,800	14.50	11.50	1,300	7517228	
CAPT4961*4A*	A*VC961205DNA*	39,000	30,800	14.50	11.50	1,450	7517219	
CAPT4961*4A*	A*VM971205DNA*	39,000	30,800	14.50	11.50	1,300	7517222	

See Notes on Page 56.

OUTDOOR UNIT	INDOOR UNITS		COOLING RATINGS				CFM	AHRI #	
	COILS/AIR HANDLERS	FURNACES	TOTAL ¹	SENS. ¹	SEER ²	EER ³			
GSX14 0421K* (cont.)	CAPT4961*4A*	G*VC80805C*B*	39,000	30,800	14.50	11.50	1,425	7517225	
	CAPT4961*4A*	A*VC81005C*B*	39,000	30,800	14.50	11.50	1,370	7517216	
	CAPT4961*4A*	A*VC960804CNA*	39,000	30,800	14.50	11.50	1,385	7517217	
	CAPT4961*4A*	A*VC80805C*B*	39,000	30,800	14.50	11.50	1,425	7517215	
	CAPT4961*4A*	G*E81005C*B*	39,000	30,800	14.50	11.50	1,425	7517224	
	CAPT4961*4A*	A*VM971005CNA*	39,000	30,800	14.50	11.50	1,300	7517221	
	CAPT4961*4A*	G*VM971005CNA*	39,000	30,800	14.50	11.50	1,300	7517231	
	CAPT4961*4A*	G*VC961205DNA*	39,000	30,800	14.50	11.50	1,450	7517229	
	CAPT4961*4A*	G*E80805C*B*	39,000	30,800	14.50	11.50	1,425	7517223	
	CAPT4961*4A*	G*VM970804CNA*	39,000	30,800	14.50	11.50	1,430	7517230	
	CAPT4961*4A*	G*VC81005C*B*	39,000	30,800	14.50	11.50	1,370	7517226	
	CAPT4961*4A*	G*VC960804CNA*	39,000	30,800	14.50	11.50	1,385	7517227	
	CAPT4961*4A*	A*VM970804CNA*	39,000	30,800	14.50	11.50	1,430	7517220	
	CAPT4961*4A*	G*VM971205DNA*	39,000	30,800	14.50	11.50	1,300	7517232	
	CAPT4961*4A*	A*VC961005CNA*	39,000	30,800	14.50	11.50	1,300	7517218	
	CAPT4961*4A*+EEP			39,000	30,800	14.00	11.50	1,275	7517212
	CAPT4961*4A*+MBVC1600**-1A*			39,000	30,800	14.50	12.20	1,300	7517213
	CAPT4961*4A*+MBVC2000**-1A*			39,000	30,800	14.50	12.20	1,300	7517214
	CHPF4860D6D*	G*VM971005CNA*		38,000	30,000	14.50	12.20	1,300	7517271
	CHPF4860D6D*	G*VC960804CNA*		38,000	30,000	14.50	12.20	1,385	7517269
	CHPF4860D6D*	G*VC961205DNA*		38,000	30,000	14.50	12.20	1,425	7520345
	CHPF4860D6D*	G*VC80805C*B*		38,000	30,000	14.50	12.20	1,400	7517267
	CHPF4860D6D*	A*VC961005CNA*		38,000	30,000	14.50	12.20	1,300	7517259
	CHPF4860D6D*	G*E81005C*B*		38,000	30,000	14.50	12.20	1,425	7517264
	CHPF4860D6D*	A*VC80805C*B*		38,000	30,000	14.50	12.20	1,400	7517256
	CHPF4860D6D*	A*EC961004CNA*		38,000	30,000	14.50	12.20	1,275	7517254
	CHPF4860D6D*	G*E80805D*A*		38,000	30,000	14.50	12.20	1,425	7517263
	CHPF4860D6D*	A*VM971205DNA*		38,000	30,000	14.50	12.20	1,300	7517261
	CHPF4860D6D*	A*VC960804CNA*		38,000	30,000	14.50	12.20	1,385	7517258
	CHPF4860D6D*	G*VC961005CNA*		38,000	30,000	14.50	12.20	1,300	7517270
	CHPF4860D6D*	G*VC81005C*B*		38,000	30,000	14.50	12.20	1,370	7517268
	CHPF4860D6D*	G*VM971205DNA*		38,000	30,000	14.50	12.20	1,300	7517272
	CHPF4860D6D*	G*EC961205DNA*		38,000	30,000	14.50	12.20	1,400	7517266
	CHPF4860D6D*	A*VM970804CNA*		38,000	30,000	14.50	12.20	1,425	7520344
	CHPF4860D6D*	G*VM970804CNA*		38,000	30,000	14.50	12.20	1,425	7520346
	CHPF4860D6D*	G*E80805C*B*		38,000	30,000	14.50	12.20	1,425	7517262
	CHPF4860D6D*	A*VM971005CNA*		38,000	30,000	14.50	12.20	1,300	7517260
	CHPF4860D6D*	A*EC961205DNA*		38,000	30,000	14.50	12.20	1,400	7517255
	CHPF4860D6D*	G*EC961004CNA*		38,000	30,000	14.50	12.20	1,275	7517265
	CHPF4860D6D*	A*VC81005C*B*		38,000	30,000	14.50	12.20	1,370	7517257
	CHPF4860D6D*	A*VC961205DNA*		38,000	30,000	14.50	12.20	1,425	7520343
	CHPF4860D6D*+EEP			38,000	30,000	14.00	12.00	1,425	7520337
	CHPF4860D6D*+EEP+TXV			38,000	30,000	14.00	12.20	1,425	7520338
	CHPF4860D6D*+MBVC1600**-1A*			38,000	30,000	14.50	12.20	1,400	7517233
	CHPF4860D6D*+MBVC2000**-1A*			38,000	30,000	14.50	12.20	1,400	7517234
CHPF4860D6D*+TXV	A*VM970804CNA*		38,000	30,000	14.50	12.20	1,425	7520340	
CHPF4860D6D*+TXV	G*E81005C*B*		38,000	30,000	14.50	12.20	1,425	7517245	
CHPF4860D6D*+TXV	A*EC961004CNA*		38,000	30,000	14.50	12.20	1,275	7517235	

See Notes on Page 56.

OUTDOOR UNIT	INDOOR UNITS		COOLING RATINGS				CFM	AHRI #
	COILS/AIR HANDLERS	FURNACES	TOTAL ¹	SENS. ¹	SEER ²	EER ³		
GSX14 0421K* (cont.)	CHPF4860D6D*+TXV	G*VM971205DNA*	38,000	30,000	14.50	12.20	1,300	7517253
	CHPF4860D6D*+TXV	G*EC961004CNA*	38,000	30,000	14.50	12.20	1,275	7517246
	CHPF4860D6D*+TXV	G*VC961005CNA*	38,000	30,000	14.50	12.20	1,300	7517251
	CHPF4860D6D*+TXV	G*VC81005C*B*	38,000	30,000	14.50	12.20	1,370	7517249
	CHPF4860D6D*+TXV	A*EC961205DNA*	38,000	30,000	14.50	12.20	1,400	7517236
	CHPF4860D6D*+TXV	G*E80805D*A*	38,000	30,000	14.50	12.20	1,425	7517244
	CHPF4860D6D*+TXV	G*EC961205DNA*	38,000	30,000	14.50	12.20	1,400	7517247
	CHPF4860D6D*+TXV	A*VM971205DNA*	38,000	30,000	14.50	12.20	1,300	7517242
	CHPF4860D6D*+TXV	A*VC961005CNA*	38,000	30,000	14.50	12.20	1,300	7517240
	CHPF4860D6D*+TXV	G*VC80805C*B*	38,000	30,000	14.50	12.20	1,400	7517248
	CHPF4860D6D*+TXV	G*E80805C*B*	38,000	30,000	14.50	12.20	1,425	7517243
	CHPF4860D6D*+TXV	A*VC80805C*B*	38,000	30,000	14.50	12.20	1,400	7517237
	CHPF4860D6D*+TXV	G*VM971005CNA*	38,000	30,000	14.50	12.20	1,300	7517252
	CHPF4860D6D*+TXV	G*VC960804CNA*	38,000	30,000	14.50	12.20	1,385	7517250
	CHPF4860D6D*+TXV	A*VM971005CNA*	38,000	30,000	14.50	12.20	1,300	7517241
	CHPF4860D6D*+TXV	G*VC961205DNA*	38,000	30,000	14.50	12.20	1,425	7520341
	CHPF4860D6D*+TXV	G*VM970804CNA*	38,000	30,000	14.50	12.20	1,425	7520342
	CHPF4860D6D*+TXV	A*VC960804CNA*	38,000	30,000	14.50	12.20	1,385	7517239
	CHPF4860D6D*+TXV	A*VC961205DNA*	38,000	30,000	14.50	12.20	1,425	7520339
	CHPF4860D6D*+TXV	A*VC81005C*B*	38,000	30,000	14.50	12.20	1,370	7517238
	CSCF4860N6D*	G*EC961205DNA*	38,000	30,000	14.50	12.20	1,400	7517304
	CSCF4860N6D*	A*VC80805C*B*	38,000	30,000	14.50	11.50	1,400	7517294
	CSCF4860N6D*	A*VC81005C*B*	38,000	30,000	14.50	11.50	1,370	7517295
	CSCF4860N6D*	A*VM971005CNA*	38,000	30,000	14.50	11.50	1,300	7517298
	CSCF4860N6D*	G*VC961005CNA*	38,000	30,000	14.50	11.50	1,300	7517308
	CSCF4860N6D*	G*VM970804CNA*	38,000	30,000	14.50	11.50	1,425	7520356
	CSCF4860N6D*	G*E80805C*B*	38,000	30,000	14.50	11.50	1,425	7517300
	CSCF4860N6D*	G*E81005C*B*	38,000	30,000	14.50	11.50	1,425	7517302
	CSCF4860N6D*	A*EC961004CNA*	38,000	30,000	14.50	12.20	1,275	7517292
	CSCF4860N6D*	A*VM970804CNA*	38,000	30,000	14.50	11.50	1,425	7520354
	CSCF4860N6D*	G*VM971205DNA*	38,000	30,000	14.50	11.50	1,300	7517310
	CSCF4860N6D*	A*EC961205DNA*	38,000	30,000	14.50	12.20	1,400	7517293
	CSCF4860N6D*	A*VM971205DNA*	38,000	30,000	14.50	11.50	1,300	7517299
	CSCF4860N6D*	G*VC961205DNA*	38,000	30,000	14.50	11.50	1,425	7520355
	CSCF4860N6D*	A*VC961205DNA*	38,000	30,000	14.50	11.50	1,425	7520353
	CSCF4860N6D*	G*EC961004CNA*	38,000	30,000	14.50	12.20	1,275	7517303
	CSCF4860N6D*	A*VC960804CNA*	38,000	30,000	14.50	11.50	1,385	7517296
	CSCF4860N6D*	G*VC960804CNA*	38,000	30,000	14.50	11.50	1,385	7517307
	CSCF4860N6D*	G*VC81005C*B*	38,000	30,000	14.50	11.50	1,370	7517306
	CSCF4860N6D*	G*VM971005CNA*	38,000	30,000	14.50	11.50	1,300	7517309
	CSCF4860N6D*	A*VC961005CNA*	38,000	30,000	14.50	11.50	1,300	7517297
	CSCF4860N6D*	G*E80805D*A*	38,000	30,000	14.50	11.50	1,425	7517301
CSCF4860N6D*	G*VC80805C*B*	38,000	30,000	14.50	11.50	1,400	7517305	
CSCF4860N6D*+EEP		38,000	30,000	14.00	11.50	1,425	7520347	
CSCF4860N6D*+EEP+TXV		38,000	30,000	14.00	11.50	1,425	7520348	
CSCF4860N6D*+TXV	G*EC961004CNA*	38,000	30,000	14.50	12.20	1,275	7517284	
CSCF4860N6D*+TXV	A*VM971205DNA*	38,000	30,000	14.50	11.50	1,300	7517280	
CSCF4860N6D*+TXV	G*EC961205DNA*	38,000	30,000	14.50	12.20	1,400	7517285	

See Notes on Page 65.

OUTDOOR UNIT	INDOOR UNITS		COOLING RATINGS				CFM	AHRI #
	COILS/AIR HANDLERS	FURNACES	TOTAL ¹	SENS. ¹	SEER ²	EER ³		
GSX14 0421K* (cont.)	CSCF4860N6D*+TXV	G*VM971205DNA*	38,000	30,000	14.50	11.50	1,300	7517291
	CSCF4860N6D*+TXV	G*VC80805C*B*	38,000	30,000	14.50	11.50	1,400	7517286
	CSCF4860N6D*+TXV	A*VC80805C*B*	38,000	30,000	14.50	11.50	1,400	7517275
	CSCF4860N6D*+TXV	A*VC961205DNA*	38,000	30,000	14.50	11.50	1,425	7520349
	CSCF4860N6D*+TXV	A*VM970804CNA*	38,000	30,000	14.50	11.50	1,425	7520350
	CSCF4860N6D*+TXV	G*E80805C*B*	38,000	30,000	14.50	11.50	1,425	7517281
	CSCF4860N6D*+TXV	A*EC961004CNA*	38,000	30,000	14.50	12.20	1,275	7517273
	CSCF4860N6D*+TXV	G*VM970804CNA*	38,000	30,000	14.50	11.50	1,425	7520352
	CSCF4860N6D*+TXV	G*E80805D*A*	38,000	30,000	14.50	11.50	1,425	7517282
	CSCF4860N6D*+TXV	A*VM971005CNA*	38,000	30,000	14.50	11.50	1,300	7517279
	CSCF4860N6D*+TXV	A*VC961005CNA*	38,000	30,000	14.50	11.50	1,300	7517278
	CSCF4860N6D*+TXV	A*VC81005C*B*	38,000	30,000	14.50	11.50	1,370	7517276
	CSCF4860N6D*+TXV	G*VC961005CNA*	38,000	30,000	14.50	11.50	1,300	7517289
	CSCF4860N6D*+TXV	G*VC960804CNA*	38,000	30,000	14.50	11.50	1,385	7517288
	CSCF4860N6D*+TXV	G*VC81005C*B*	38,000	30,000	14.50	11.50	1,370	7517287
	CSCF4860N6D*+TXV	G*VC961205DNA*	38,000	30,000	14.50	11.50	1,425	7520351
	CSCF4860N6D*+TXV	G*E81005C*B*	38,000	30,000	14.50	11.50	1,425	7517283
	CSCF4860N6D*+TXV	A*VC960804CNA*	38,000	30,000	14.50	11.50	1,385	7517277
	CSCF4860N6D*+TXV	G*VM971005CNA*	38,000	30,000	14.50	11.50	1,300	7517290
	CSCF4860N6D*+TXV	A*EC961205DNA*	38,000	30,000	14.50	12.20	1,400	7517274
GSX14 0481K*	ASPT48D14A*		46,000	32,600	14.50	11.50	1,600	7517311
	ASPT60D14A*		46,000	32,600	14.50	11.50	1,600	7517312
	AVPTC48D14A*		46,000	32,600	14.50	11.50	1,550	7517313
	AVPTC60D14A*		46,000	32,600	14.50	11.50	1,590	7517314
	CA*F4860*6D*	A*VM971005CNA*	45,500	32,200	14.50	11.70	1,450	7517344
	CA*F4860*6D*	G*VC961205DNA*	45,500	32,200	14.50	11.70	1,450	7517348
	CA*F4860*6D*	A*VM970804CNA*	45,000	31,800	14.50	11.70	1,385	7517343
	CA*F4860*6D*	A*VM971205DNA*	45,500	32,200	14.50	11.70	1,450	7517345
	CA*F4860*6D*	G*VM970804CNA*	45,000	31,800	14.50	11.70	1,385	7517349
	CA*F4860*6D*	G*VM971005CNA*	45,500	32,200	14.50	11.70	1,450	7517350
	CA*F4860*6D*	A*VC960804CNA*	45,000	31,800	14.50	11.70	1,385	7517340
	CA*F4860*6D*	G*VC961005CNA*	45,500	32,200	14.50	11.70	1,450	7517347
	CA*F4860*6D*	A*VC961005CNA*	45,500	32,200	14.50	11.70	1,450	7517341
	CA*F4860*6D*	G*VM971205DNA*	45,500	32,200	14.50	11.70	1,450	7517351
	CA*F4860*6D*	G*VC960804CNA*	45,000	31,800	14.50	11.70	1,385	7517346
	CA*F4860*6D*	A*VC961205DNA*	45,500	32,200	14.50	11.70	1,450	7517342
	CA*F4860*6D*+EEP		45,500	32,200	14.00	11.70	1,550	7517315
	CA*F4860*6D*+EEP+TXV		45,500	32,200	14.00	11.70	1,550	7517316
	CA*F4860*6D*+MBVC2000**-1A*+TXV		46,000	32,600	14.50	12.00	1,600	7517317
	CA*F4860*6D*+TXV	A*VC81005C*B*	45,500	32,200	14.50	11.70	1,530	7517321
	CA*F4860*6D*+TXV	G*VC961205DNA*	45,500	32,200	14.50	12.00	1,450	7517336
	CA*F4860*6D*+TXV	G*VM971005CNA*	45,500	32,200	14.50	12.00	1,450	7517338
	CA*F4860*6D*+TXV	A*VM971205DNA*	45,500	32,200	14.50	12.00	1,450	7517327
	CA*F4860*6D*+TXV	G*VC80805C*B*	45,500	32,200	14.50	11.70	1,510	7517332
	CA*F4860*6D*+TXV	A*VM970804CNA*	45,000	31,800	14.50	12.00	1,385	7517325
	CA*F4860*6D*+TXV	G*E81005C*B*	45,500	32,200	14.50	11.70	1,570	7517329
	CA*F4860*6D*+TXV	G*EC961205DNA*	45,000	31,800	14.50	12.00	1,525	7517331
CA*F4860*6D*+TXV	G*VC960804CNA*	45,000	31,800	14.50	12.00	1,385	7517334	

See Notes on Page 65.

OUTDOOR UNIT	INDOOR UNITS		COOLING RATINGS				CFM	AHRI #
	COILS/AIR HANDLERS	FURNACES	TOTAL ¹	SENS. ¹	SEER ²	EER ³		
GSX14 0481K* (cont.)	CA*F4860*6D*+TXV	A*VC961205DNA*	45,500	32,200	14.50	12.00	1,450	7517324
	CA*F4860*6D*+TXV	G*VM970804CNA*	45,000	31,800	14.50	12.00	1,385	7517337
	CA*F4860*6D*+TXV	A*VC961005CNA*	45,500	32,200	14.50	12.00	1,450	7517323
	CA*F4860*6D*+TXV	G*EC961004CNA*	45,000	31,800	14.50	11.70	1,525	7517330
	CA*F4860*6D*+TXV	A*VM971005CNA*	45,500	32,200	14.50	12.00	1,450	7517326
	CA*F4860*6D*+TXV	A*EC961004CNA*	45,000	31,800	14.50	11.70	1,525	7517318
	CA*F4860*6D*+TXV	G*E80805C*B*	45,000	31,800	14.50	11.70	1,480	7517328
	CA*F4860*6D*+TXV	G*VC81005C*B*	45,500	32,200	14.50	11.70	1,530	7517333
	CA*F4860*6D*+TXV	A*EC961205DNA*	45,000	31,800	14.50	12.00	1,525	7517319
	CA*F4860*6D*+TXV	G*VC961005CNA*	45,500	32,200	14.50	12.00	1,450	7517335
	CA*F4860*6D*+TXV	G*VM971205DNA*	45,500	32,200	14.50	12.00	1,450	7517339
	CA*F4860*6D*+TXV	A*VC80805C*B*	45,500	32,200	14.50	11.70	1,510	7517320
	CA*F4860*6D*+TXV	A*VC960804CNA*	45,000	31,800	14.50	12.00	1,385	7517322
	CA*F4961*6D*+EEP		46,000	32,600	14.00	11.70	1,550	7517352
	CA*F4961*6D*+EEP+TXV		46,000	32,600	14.00	11.70	1,550	7517353
	CA*F4961*6D*+MBVC2000**-1A*+TXV		46,000	32,600	14.50	12.00	1,600	7517354
	CAPT4961*4A*	A*VC81005C*B*	45,500	32,200	14.50	11.70	1,530	7517359
	CAPT4961*4A*	G*VC81005C*B*	45,500	32,200	14.50	11.70	1,530	7517371
	CAPT4961*4A*	G*VC80805C*B*	45,500	32,200	14.50	11.70	1,510	7517370
	CAPT4961*4A*	G*EC961004CNA*	45,000	31,800	14.50	11.70	1,525	7517368
	CAPT4961*4A*	A*VM970804CNA*	45,000	31,800	14.50	11.70	1,385	7517363
	CAPT4961*4A*	A*VC961005CNA*	45,500	32,200	14.50	11.70	1,450	7517361
	CAPT4961*4A*	G*E81005C*B*	45,500	32,200	14.50	11.70	1,570	7517367
	CAPT4961*4A*	A*VM971205DNA*	45,500	32,200	14.50	11.70	1,450	7517365
	CAPT4961*4A*	G*VC960804CNA*	45,000	31,800	14.50	11.70	1,385	7517372
	CAPT4961*4A*	A*VM971005CNA*	45,500	32,200	14.50	11.70	1,450	7517364
	CAPT4961*4A*	A*EC961205DNA*	45,000	31,800	14.50	12.00	1,525	7517357
	CAPT4961*4A*	A*VC960804CNA*	45,000	31,800	14.50	11.70	1,385	7517360
	CAPT4961*4A*	G*VC961205DNA*	45,500	32,200	14.50	11.70	1,450	7517374
	CAPT4961*4A*	G*VM971005CNA*	45,500	32,200	14.50	11.70	1,450	7517376
	CAPT4961*4A*	A*EC961004CNA*	45,000	31,800	14.50	11.70	1,525	7517356
	CAPT4961*4A*	A*VC80805C*B*	45,500	32,200	14.50	11.70	1,510	7517358
	CAPT4961*4A*	G*VM971205DNA*	45,500	32,200	14.50	11.70	1,450	7517377
	CAPT4961*4A*	G*E80805C*B*	45,000	31,800	14.50	11.70	1,480	7517366
	CAPT4961*4A*	G*EC961205DNA*	45,000	31,800	14.50	12.00	1,525	7517369
	CAPT4961*4A*	A*VC961205DNA*	45,500	32,200	14.50	11.70	1,450	7517362
	CAPT4961*4A*	G*VM970804CNA*	45,000	31,800	14.50	11.70	1,385	7517375
	CAPT4961*4A*	G*VC961005CNA*	45,500	32,200	14.50	11.70	1,450	7517373
	CAPT4961*4A*+EEP		46,000	32,600	14.00	11.70	1,550	7517355
	CAPT4961*4A*+MBVC2000**-1A*		45,000	31,800	14.50	11.70	1,595	7517378
	CHPF4860D6D*	A*VM970804CNA*	45,000	31,800	14.50	11.70	1,385	7517407
	CHPF4860D6D*	A*VC960804CNA*	45,000	31,800	14.50	11.70	1,385	7517404
	CHPF4860D6D*	A*VM971005CNA*	45,500	32,200	14.50	11.70	1,450	7517408
	CHPF4860D6D*	A*VC961205DNA*	45,500	32,200	14.50	11.70	1,450	7517406
	CHPF4860D6D*	G*VC960804CNA*	45,000	31,800	14.50	11.70	1,385	7517410
	CHPF4860D6D*	G*VC961005CNA*	45,500	32,200	14.50	11.70	1,450	7517411
	CHPF4860D6D*	G*VM970804CNA*	45,000	31,800	14.50	11.70	1,385	7517413
	CHPF4860D6D*	G*VC961205DNA*	45,500	32,200	14.50	11.70	1,450	7517412
	CHPF4860D6D*	G*VM971005CNA*	45,500	32,200	14.50	11.70	1,450	7517414
	CHPF4860D6D*	G*VM971205DNA*	45,500	32,200	14.50	11.70	1,450	7517415
CHPF4860D6D*	A*VM971205DNA*	45,500	32,200	14.50	11.70	1,450	7517409	
CHPF4860D6D*	A*VC961005CNA*	45,500	32,200	14.50	11.70	1,450	7517405	
CHPF4860D6D*+EEP		46,000	32,600	14.00	11.70	1,550	7517379	
CHPF4860D6D*+EEP+TXV		46,000	32,600	14.00	11.70	1,550	7517380	
CHPF4860D6D*+MBVC2000**-1A*+TXV		46,000	32,600	14.50	12.00	1,600	7517381	

See Notes on Page 65.

OUTDOOR UNIT	INDOOR UNITS		COOLING RATINGS				CFM	AHRI #
	COILS/AIR HANDLERS	FURNACES	TOTAL ¹	SENS. ¹	SEER ²	EER ³		
GSX14 0481K* (cont.)	CHPF4860D6D*+TXV	G*VC81005C*B*	45,500	32,200	14.50	11.70	1,530	7517397
	CHPF4860D6D*+TXV	A*EC961004CNA*	45,000	31,800	14.50	11.70	1,525	7517382
	CHPF4860D6D*+TXV	G*VM971205DNA*	45,500	32,200	14.50	12.00	1,450	7517403
	CHPF4860D6D*+TXV	A*VC81005C*B*	45,500	32,200	14.50	11.70	1,530	7517385
	CHPF4860D6D*+TXV	G*EC961205DNA*	45,000	31,800	14.50	12.00	1,525	7517395
	CHPF4860D6D*+TXV	G*VC961205DNA*	45,500	32,200	14.50	12.00	1,450	7517400
	CHPF4860D6D*+TXV	G*VC961005CNA*	45,500	32,200	14.50	12.00	1,450	7517399
	CHPF4860D6D*+TXV	A*VC961005CNA*	45,500	32,200	14.50	12.00	1,450	7517387
	CHPF4860D6D*+TXV	A*VC80805C*B*	45,500	32,200	14.50	11.70	1,510	7517384
	CHPF4860D6D*+TXV	A*EC961205DNA*	45,000	31,800	14.50	12.00	1,525	7517383
	CHPF4860D6D*+TXV	A*VC960804CNA*	45,000	31,800	14.50	12.00	1,385	7517386
	CHPF4860D6D*+TXV	A*VC961205DNA*	45,500	32,200	14.50	12.00	1,450	7517388
	CHPF4860D6D*+TXV	G*E80805C*B*	45,000	31,800	14.50	11.70	1,480	7517392
	CHPF4860D6D*+TXV	G*E81005C*B*	45,500	32,200	14.50	11.70	1,570	7517393
	CHPF4860D6D*+TXV	A*VM970804CNA*	45,000	31,800	14.50	12.00	1,385	7517389
	CHPF4860D6D*+TXV	A*VM971005CNA*	45,500	32,200	14.50	12.00	1,450	7517390
	CHPF4860D6D*+TXV	G*VC960804CNA*	45,000	31,800	14.50	12.00	1,385	7517398
	CHPF4860D6D*+TXV	G*VM970804CNA*	45,000	31,800	14.50	12.00	1,385	7517401
	CHPF4860D6D*+TXV	G*EC961004CNA*	45,000	31,800	14.50	11.70	1,525	7517394
	CHPF4860D6D*+TXV	A*VM971205DNA*	45,500	32,200	14.50	12.00	1,450	7517391
	CHPF4860D6D*+TXV	G*VC80805C*B*	45,500	32,200	14.50	11.70	1,510	7517396
	CHPF4860D6D*+TXV	G*VM971005CNA*	45,500	32,200	14.50	12.00	1,450	7517402
	CSCF4860N6D*	G*VC960804CNA*	45,000	31,800	14.50	11.70	1,385	7517442
	CSCF4860N6D*	A*VC961205DNA*	45,500	32,200	14.50	11.70	1,450	7517438
	CSCF4860N6D*	A*VC960804CNA*	45,000	31,800	14.50	11.70	1,385	7517436
	CSCF4860N6D*	G*VC961205DNA*	45,500	32,200	14.50	11.70	1,450	7517444
	CSCF4860N6D*	G*VM971005CNA*	45,500	32,200	14.50	11.70	1,450	7517446
	CSCF4860N6D*	A*VM971005CNA*	45,500	32,200	14.50	11.70	1,450	7517440
	CSCF4860N6D*	G*VM970804CNA*	45,000	31,800	14.50	11.70	1,385	7517445
	CSCF4860N6D*	A*VC961005CNA*	45,500	32,200	14.50	11.70	1,450	7517437
	CSCF4860N6D*	G*VC961005CNA*	45,500	32,200	14.50	11.70	1,450	7517443
	CSCF4860N6D*	A*VM971205DNA*	45,500	32,200	14.50	11.70	1,450	7517441
	CSCF4860N6D*	G*VM971205DNA*	45,500	32,200	14.50	11.70	1,450	7517447
	CSCF4860N6D*	A*VM970804CNA*	45,000	31,800	14.50	11.70	1,385	7517439
	CSCF4860N6D*+EEP		45,500	32,200	14.00	11.70	1,550	7517416
	CSCF4860N6D*+EEP+TXV		45,500	32,200	14.00	11.70	1,550	7517417
	CSCF4860N6D*+TXV	A*VC960804CNA*	45,000	31,800	14.50	12.00	1,385	7517420
	CSCF4860N6D*+TXV	A*VM971005CNA*	45,500	32,200	14.50	11.70	1,450	7517424
	CSCF4860N6D*+TXV	G*VC81005C*B*	45,500	32,200	14.50	11.70	1,530	7517429
	CSCF4860N6D*+TXV	A*VC80805C*B*	45,500	32,200	14.50	11.70	1,510	7517418
	CSCF4860N6D*+TXV	G*VM971005CNA*	45,500	32,200	14.50	11.70	1,450	7517434
	CSCF4860N6D*+TXV	A*VM971205DNA*	45,500	32,200	14.50	11.70	1,450	7517425
	CSCF4860N6D*+TXV	G*VC80805C*B*	45,500	32,200	14.50	11.70	1,510	7517428
	CSCF4860N6D*+TXV	G*VC961005CNA*	45,500	32,200	14.50	11.70	1,450	7517431
	CSCF4860N6D*+TXV	G*VC960804CNA*	45,000	31,800	14.50	12.00	1,385	7517430
	CSCF4860N6D*+TXV	A*VC961005CNA*	45,500	32,200	14.50	11.70	1,450	7517421
	CSCF4860N6D*+TXV	G*VM971205DNA*	45,500	32,200	14.50	11.70	1,450	7517435
	CSCF4860N6D*+TXV	A*VC81005C*B*	45,500	32,200	14.50	11.70	1,530	7517419
CSCF4860N6D*+TXV	G*E81005C*B*	45,000	31,800	14.50	11.70	1,570	7517427	
CSCF4860N6D*+TXV	G*E80805C*B*	45,000	31,800	14.50	11.70	1,480	7517426	
CSCF4860N6D*+TXV	G*VM970804CNA*	45,000	31,800	14.50	11.70	1,385	7517433	
CSCF4860N6D*+TXV	A*VM970804CNA*	45,000	31,800	14.50	11.70	1,385	7517423	
CSCF4860N6D*+TXV	A*VC961205DNA*	45,500	32,200	14.50	11.70	1,450	7517422	
CSCF4860N6D*+TXV	G*VC961205DNA*	45,500	32,200	14.50	11.70	1,450	7517432	

See Notes on Page 65.

OUTDOOR UNIT	INDOOR UNITS		COOLING RATINGS				CFM	AHRI #
	COILS/AIR HANDLERS	FURNACES	TOTAL ¹	SENS. ¹	SEER ²	EER ³		
GSX14 0601K*	ASPT60D14A*		57,000	40,000	14.00	11.70	1,620	7517448
	AVPTC60D14A*		57,000	40,000	14.00	11.70	1,620	7517449
	CA*F4961*6D*	A*VC961205DNA*	56,500	40,000	14.00	11.70	1,575	7517469
	CA*F4961*6D*	A*VM971205DNA*	56,500	40,000	14.00	11.70	1,575	7517470
	CA*F4961*6D*	G*VM971205DNA*	56,500	40,000	14.00	11.70	1,575	7517472
	CA*F4961*6D*	G*VC961205DNA*	56,500	40,000	14.00	11.70	1,575	7517471
	CA*F4961*6D*+EEP+TXV		57,000	40,000	14.00	11.70	1,545	7517450
	CA*F4961*6D*+MBVC2000**-1A*+TXV		57,000	40,000	14.50	12.00	1,620	7517451
	CA*F4961*6D*+TXV	A*EC961205DNA*	57,000	40,000	14.00	11.70	1,525	7517452
	CA*F4961*6D*+TXV	A*VM971005CNA*	57,000	40,000	14.00	11.70	1,525	7517457
	CA*F4961*6D*+TXV	A*VC81005C*B*	57,000	40,000	14.50	11.70	1,525	7517454
	CA*F4961*6D*+TXV	A*VC961005CNA*	57,000	40,000	14.00	11.70	1,525	7517455
	CA*F4961*6D*+TXV	G*E81005C*B*	57,000	40,000	14.50	11.70	1,600	7517461
	CA*F4961*6D*+TXV	A*VM971205DNA*	57,000	40,000	14.50	12.00	1,575	7517458
	CA*F4961*6D*+TXV	A*VC961205DNA*	57,000	40,000	14.50	12.00	1,575	7517456
	CA*F4961*6D*+TXV	G*VC80805C*B*	57,000	40,000	14.50	11.70	1,560	7517463
	CA*F4961*6D*+TXV	G*VC81005C*B*	57,000	40,000	14.50	11.70	1,525	7517464
	CA*F4961*6D*+TXV	G*VM971205DNA*	57,000	40,000	14.50	12.00	1,575	7517468
	CA*F4961*6D*+TXV	A*VC80805C*B*	57,000	40,000	14.50	11.70	1,560	7517453
	CA*F4961*6D*+TXV	G*E80805D*A*	57,000	40,000	14.50	12.00	1,500	7517460
	CA*F4961*6D*+TXV	G*VM971005CNA*	57,000	40,000	14.00	11.70	1,525	7517467
	CA*F4961*6D*+TXV	G*VC961005CNA*	57,000	40,000	14.00	11.70	1,525	7517465
	CA*F4961*6D*+TXV	G*EC961205DNA*	57,000	40,000	14.00	11.70	1,525	7517462
	CA*F4961*6D*+TXV	G*VC961205DNA*	57,000	40,000	14.50	12.00	1,575	7517466
	CA*F4961*6D*+TXV	G*E80805C*B*	57,000	40,000	14.50	11.70	1,525	7517459
	CAPT4961*4A*	A*VC961005CNA*	57,000	40,000	14.00	11.70	1,525	7517482
	CAPT4961*4A*	G*VM971205DNA*	56,500	40,000	14.00	11.70	1,575	7517490
	CAPT4961*4A*	G*VC961205DNA*	56,500	40,000	14.00	11.70	1,575	7517488
	CAPT4961*4A*	G*VC81005C*B*	57,000	40,000	14.00	11.70	1,525	7517480
	CAPT4961*4A*	G*VC80805C*B*	57,000	40,000	14.00	11.70	1,560	7517479
	CAPT4961*4A*	A*VM971005CNA*	57,000	40,000	14.00	11.70	1,525	7517484
	CAPT4961*4A*	A*VC961205DNA*	56,500	40,000	14.00	11.70	1,575	7517483
	CAPT4961*4A*	G*VC961005CNA*	57,000	40,000	14.00	11.70	1,525	7517487
	CAPT4961*4A*	G*EC961205DNA*	56,500	40,000	14.00	11.70	1,525	7517486
	CAPT4961*4A*	G*VM971005CNA*	57,000	40,000	14.00	11.70	1,525	7517489
	CAPT4961*4A*	A*VC80805C*B*	57,000	40,000	14.00	11.70	1,560	7517474
	CAPT4961*4A*	A*VM971205DNA*	56,500	40,000	14.00	11.70	1,575	7517485
	CAPT4961*4A*	A*VC81005C*B*	57,000	40,000	14.00	11.70	1,525	7517475
	CAPT4961*4A*	A*EC961205DNA*	56,500	40,000	14.00	11.70	1,525	7517481
	CAPT4961*4A*	G*E80805C*B*	57,000	40,000	14.00	11.70	1,525	7517476
	CAPT4961*4A*	G*E80805D*A*	57,000	40,000	14.00	12.00	1,500	7517477
	CAPT4961*4A*	G*E81005C*B*	57,000	40,000	14.00	11.70	1,600	7517478
CAPT4961*4A*+EEP		57,000	40,000	14.00	11.70	1,545	7517473	
CHPF4860D6D*	A*VC961205DNA*	56,500	40,000	14.00	11.70	1,575	7517510	
CHPF4860D6D*	G*VM971205DNA*	56,500	40,000	14.00	11.70	1,575	7517513	
CHPF4860D6D*	A*VM971205DNA*	56,500	40,000	14.00	11.70	1,575	7517511	
CHPF4860D6D*	G*VC961205DNA*	56,500	40,000	14.00	11.70	1,575	7517512	
CHPF4860D6D*+EEP+TXV		57,000	40,000	14.00	11.70	1,545	7517491	

See Notes on Page 65.

OUTDOOR UNIT	INDOOR UNITS		COOLING RATINGS				CFM	AHRI #
	COILS/AIR HANDLERS	FURNACES	TOTAL ¹	SENS. ¹	SEER ²	EER ³		
GSX14 0601K* (cont.)	CHPF4860D6D*+MBVC2000**-1A*+TXV		57,000	40,000	14.50	12.00	1,620	7517492
	CHPF4860D6D*+TXV	G*E81005C*B*	57,000	40,000	14.50	11.70	1,600	7517502
	CHPF4860D6D*+TXV	A*VC81005C*B*	57,000	40,000	14.50	11.70	1,525	7517495
	CHPF4860D6D*+TXV	A*VC961205DNA*	57,000	40,000	14.50	12.00	1,575	7517497
	CHPF4860D6D*+TXV	G*E80805C*B*	57,000	40,000	14.50	11.70	1,525	7517500
	CHPF4860D6D*+TXV	A*VM971005CNA*	57,000	40,000	14.00	11.70	1,525	7517498
	CHPF4860D6D*+TXV	A*EC961205DNA*	57,000	40,000	14.00	11.70	1,525	7517493
	CHPF4860D6D*+TXV	G*VM971205DNA*	57,000	40,000	14.50	12.00	1,575	7517509
	CHPF4860D6D*+TXV	G*VM971005CNA*	57,000	40,000	14.00	11.70	1,525	7517508
	CHPF4860D6D*+TXV	A*VM971205DNA*	57,000	40,000	14.50	12.00	1,575	7517499
	CHPF4860D6D*+TXV	A*VC961005CNA*	57,000	40,000	14.00	11.70	1,525	7517496
	CHPF4860D6D*+TXV	G*VC81005C*B*	57,000	40,000	14.50	11.70	1,525	7517505
	CHPF4860D6D*+TXV	A*VC80805C*B*	57,000	40,000	14.50	11.70	1,560	7517494
	CHPF4860D6D*+TXV	G*VC80805C*B*	57,000	40,000	14.50	11.70	1,560	7517504
	CHPF4860D6D*+TXV	G*VC961205DNA*	57,000	40,000	14.50	12.00	1,575	7517507
	CHPF4860D6D*+TXV	G*EC961205DNA*	57,000	40,000	14.00	11.70	1,525	7517503
	CHPF4860D6D*+TXV	G*E80805D*A*	57,000	40,000	14.50	12.00	1,500	7517501
	CHPF4860D6D*+TXV	G*VC961005CNA*	57,000	40,000	14.00	11.70	1,525	7517506
	CSCF4860N6D*	A*VM971205DNA*	56,500	40,000	14.00	11.70	1,575	7517534
	CSCF4860N6D*	A*VC961205DNA*	56,500	40,000	14.00	11.70	1,575	7517533
	CSCF4860N6D*	G*VM971205DNA*	56,500	40,000	14.00	11.70	1,575	7517536
	CSCF4860N6D*	G*VC961205DNA*	56,500	40,000	14.00	11.70	1,575	7517535
	CSCF4860N6D*+EEP+TXV		57,000	40,000	14.00	11.70	1,545	7517514
	CSCF4860N6D*+MBVC2000**-1A*+TXV		57,000	40,000	14.50	12.00	1,620	7517515
	CSCF4860N6D*+TXV	G*VC81005C*B*	57,000	40,000	14.50	11.70	1,525	7517528
	CSCF4860N6D*+TXV	A*VM971205DNA*	57,000	40,000	14.50	12.00	1,575	7517522
	CSCF4860N6D*+TXV	G*E80805C*B*	57,000	40,000	14.50	11.70	1,525	7517523
	CSCF4860N6D*+TXV	A*VC961005CNA*	57,000	40,000	14.00	11.70	1,525	7517519
	CSCF4860N6D*+TXV	G*VC80805C*B*	57,000	40,000	14.50	11.70	1,560	7517527
	CSCF4860N6D*+TXV	A*VC81005C*B*	57,000	40,000	14.50	11.70	1,525	7517518
	CSCF4860N6D*+TXV	G*VM971005CNA*	57,000	40,000	14.00	11.70	1,525	7517531
	CSCF4860N6D*+TXV	A*VC80805C*B*	57,000	40,000	14.50	11.70	1,560	7517517
	CSCF4860N6D*+TXV	G*VC961005CNA*	57,000	40,000	14.00	11.70	1,525	7517529
CSCF4860N6D*+TXV	G*E80805D*A*	57,000	40,000	14.50	12.00	1,500	7517524	
CSCF4860N6D*+TXV	G*EC961205DNA*	57,000	40,000	14.00	11.70	1,525	7517526	
CSCF4860N6D*+TXV	A*EC961205DNA*	57,000	40,000	14.00	11.70	1,525	7517516	
CSCF4860N6D*+TXV	G*E81005C*B*	57,000	40,000	14.50	11.70	1,600	7517525	
CSCF4860N6D*+TXV	A*VC961205DNA*	57,000	40,000	14.50	12.00	1,575	7517520	
CSCF4860N6D*+TXV	G*VC961205DNA*	57,000	40,000	14.50	12.00	1,575	7517530	
CSCF4860N6D*+TXV	A*VM971005CNA*	57,000	40,000	14.00	11.70	1,525	7517521	
CSCF4860N6D*+TXV	G*VM971205DNA*	57,000	40,000	14.50	12.00	1,575	7517532	

¹ BTU/h

² Seasonal Energy Efficiency Ratio; Certified per AHRI 210/240 @ 80°F/ 67°F/ 95°F

³ Energy Efficiency Ratio @ 80°F/ 67°F/ 95°F

NOTES

- Always check the S&R plate for electrical data on the unit being installed.
- When matching the outdoor unit to the indoor unit, use the piston supplied with the outdoor unit or that specified on the piston kit chart supplied with the indoor unit.
- EEP - Order from Service Dept. Part No. B13707-38 or new Solid State Board B13707-35S. Part No. B13707-38 is not interchangeable with B13707-35S. The Goodman Gas Furnace contains the EEP cooling time delay

DIMENSIONS

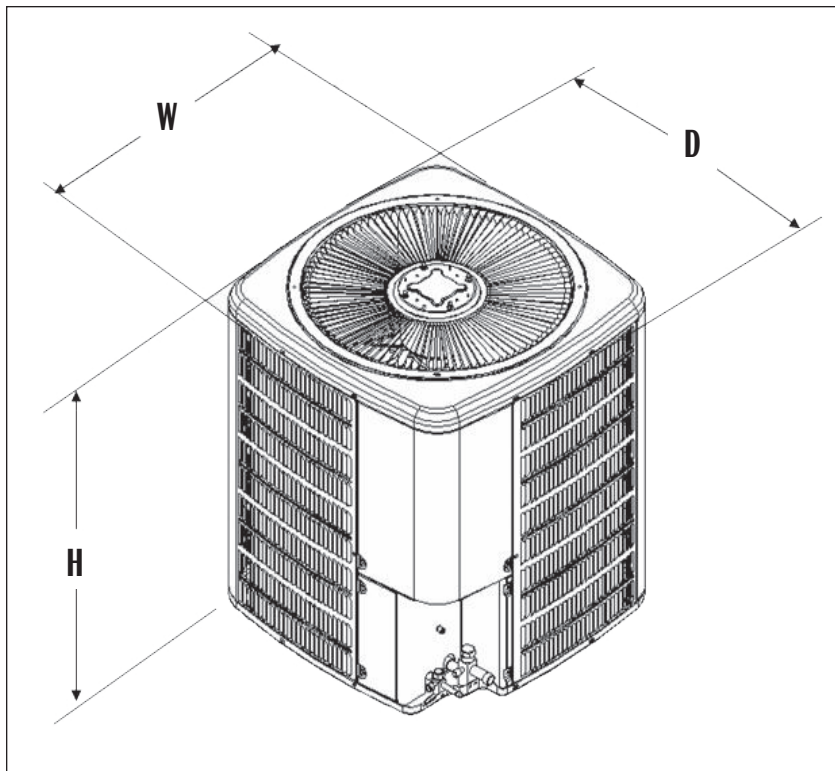

MODEL	DIMENSIONS		
	W"	D"	H"
GSX140181**	26	26	27½
GSX140191**	26	26	27½
GSX140241**	26	26	27½
GSX140251**	26	26	27½
GSX140301**	29	29	32½
GSX140311**	29	29	32½
GSX140361**	29	29	32½
GSX140371**	29	29	32½
GSX140421**	29	29	36¼
GSX140481**	35½	35½	36¼
GSX140601**	35½	35½	38¼

WIRING DIAGRAM

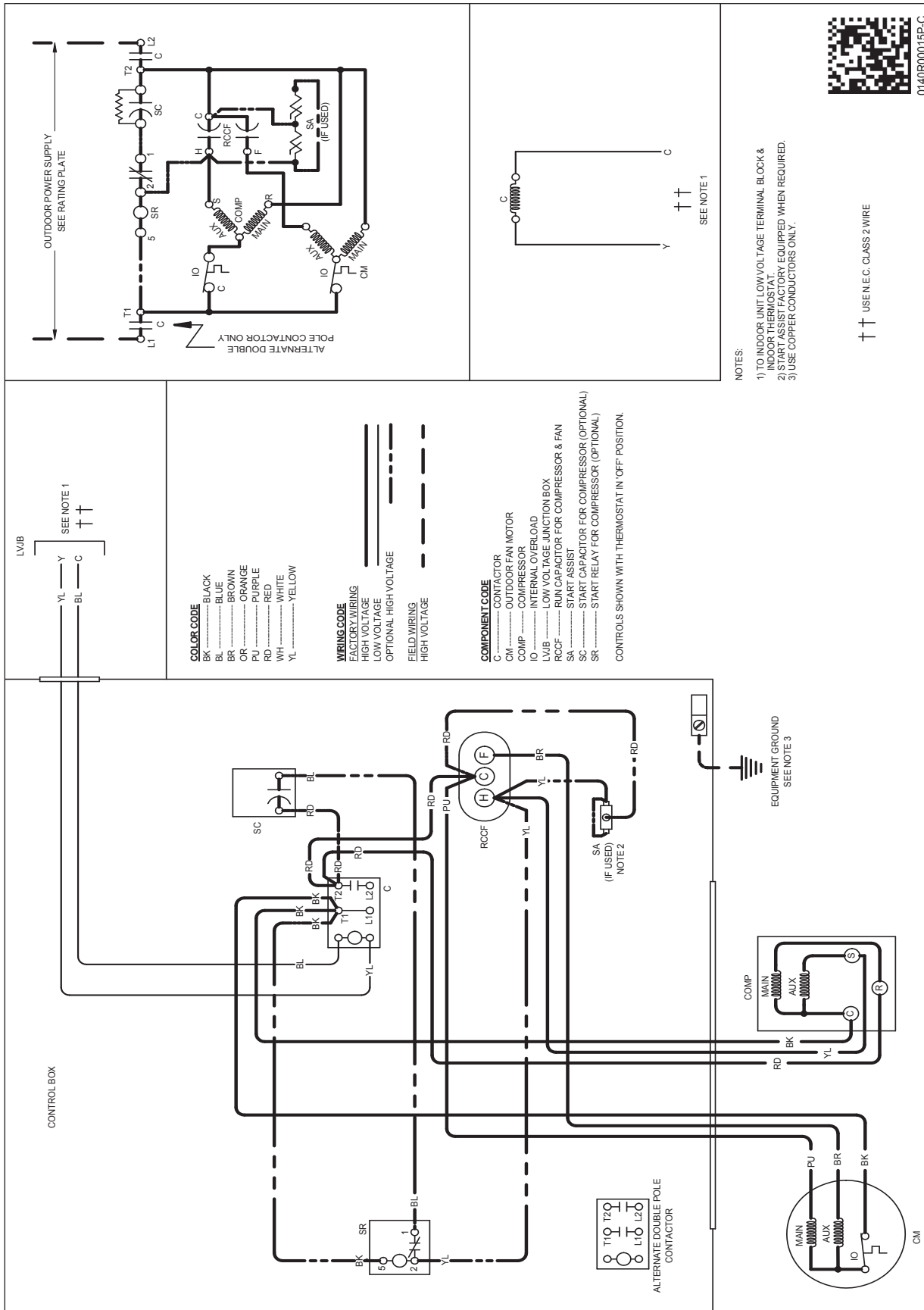

0140R00015P-C

NOTES:

- 1) TO INDOOR UNIT LOW VOLTAGE TERMINAL BLOCK & INDOOR THERMOSTAT.
- 2) START ASSIST FACTORY EQUIPPED WHEN REQUIRED.
- 3) USE COPPER CONDUCTIONS ONLY.

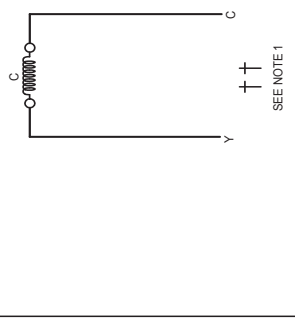

†† USE N.E.C. CLASS 2 WIRE

WARNING

High Voltage: Disconnect all power before servicing or installing this unit. Multiple power sources may be present. Failure to do so may cause property damage, personal injury, or death.

Wiring is subject to change. Always refer to the wiring diagram or the unit for the most up-to-date wiring.

ACCESSORIES

MODEL #	DESCRIPTION	GSX14 018/19**	GSX14 024/25**	GSX14 030/31**	GSX14 036/37**	GSX14 042**	GSX14 048**	GSX14 060**
ABK-20	Anchor Bracket Kit ^			X	X	X	X	X
ABK-21	Anchor Bracket Kit ^	X	X					
ASC-01	Anti-Short Cycle Kit	X	X	X	X	X	X	X
CSR-U-1	Hard-start Kit		X	X	X			
CSR-U-2	Hard-start Kit	X				X	X	X
CSR-U-3	Hard-start Kit						X	X
FSK01A ¹	Freeze Protection Kit	X	X	X	X	X	X	X
LSK02A ²	Liquid Line Solenoid Kit	X	X	X	X	X	X	X
TX2N4 ²	TXV Kit	X						
TX2N4A ²	TXV Kit	X	X					
TX3N4 ²	TXV Kit			X	X			
TX5N4 ²	TXV Kit					X	X	X

^ Contains 20 brackets; four brackets needed to anchor unit to pad

¹ Installed on indoor coil

² Field-installed, non-bleed, expansion valve kit — Condensing units and heat pumps with reciprocating compressors require start-assist components when used in conjunction with an indoor coil using a non-bleed thermal expansion valve refrigerant metering device.