

TECHNICAL MANUAL

AVPTC Air Handlers

- Refer to Service Manual RS6200006 for installation, operation & troubleshooting information.
- All safety information must be followed as provided in the Service Manual.
- Refer to the appropriate Parts Catalog for part number information.
- Models listed on page 3.

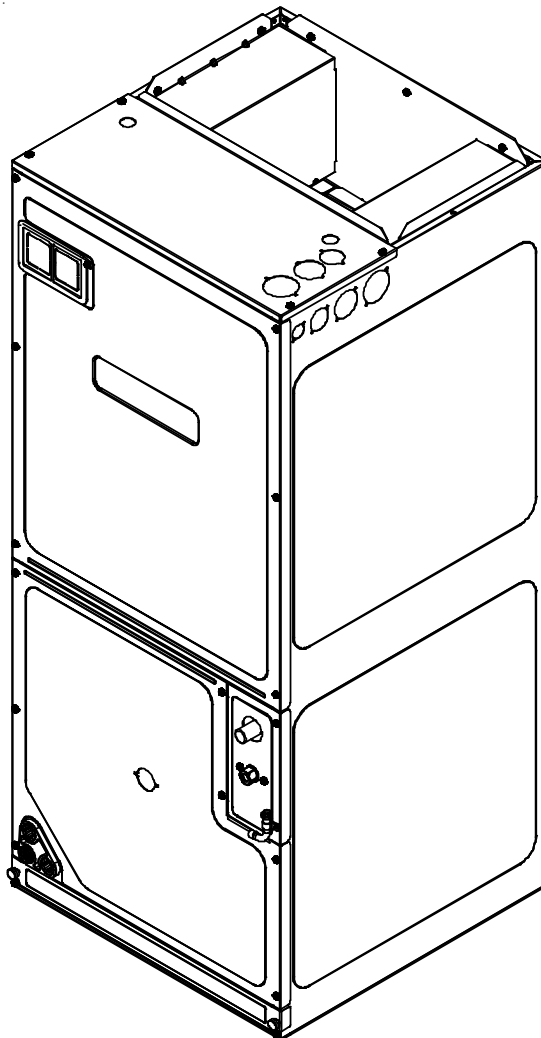

This manual is to be used by qualified, professionally trained HVAC technicians only. Goodman does not assume any responsibility for property damage or personal injury due to improper service procedures or services performed by an unqualified person.

RT6121004r4
July 2014

PRODUCT IDENTIFICATION

The model number is used for positive identification of component parts used in manufacturing. Please use this number when requesting service or parts information.

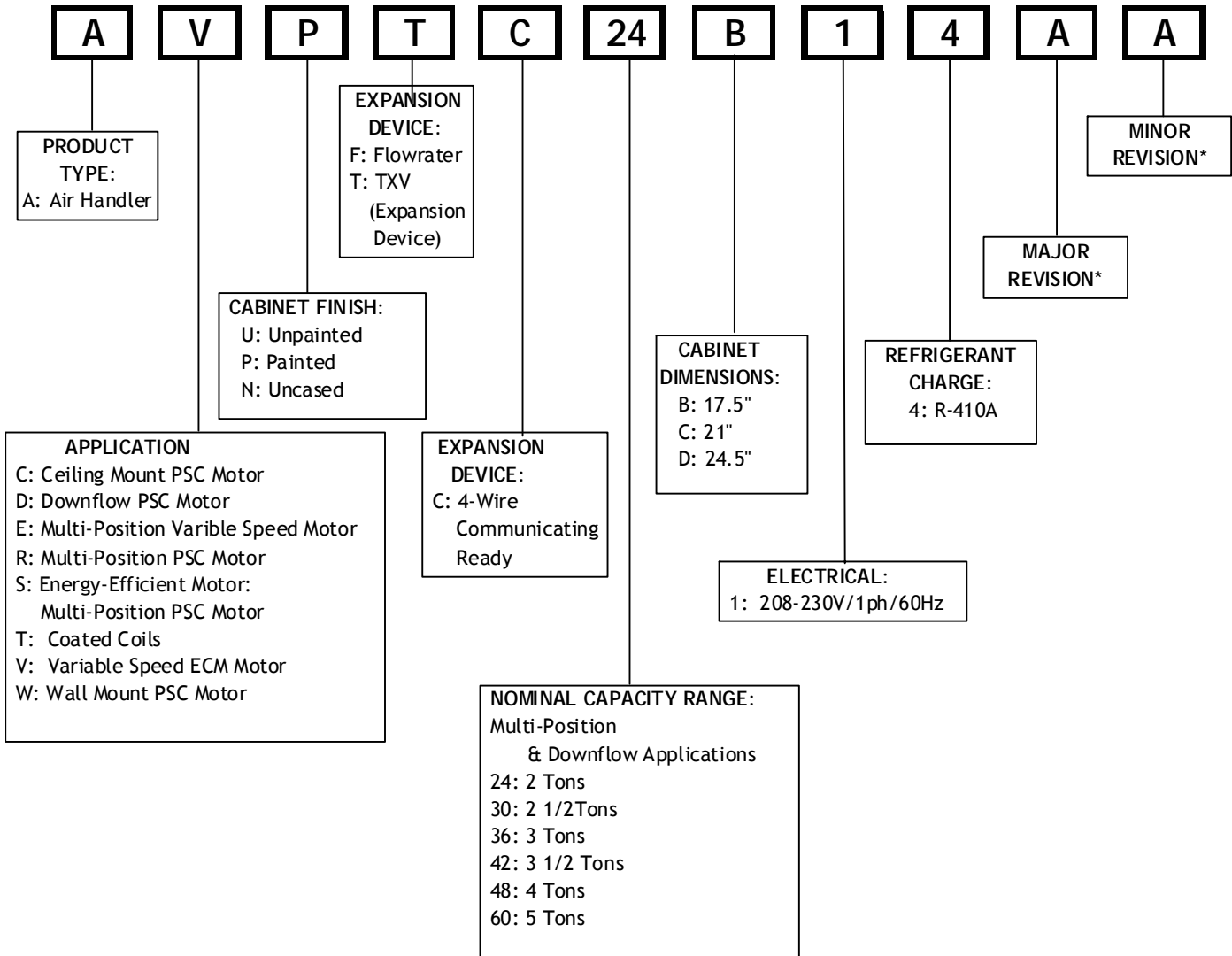

All Airhandlers use DIRECT DRIVE MOTORS. Power supply is AC 208-230v, 60 hz, 1 phase.

WARNING

HIGH VOLTAGE!

Disconnect ALL power before servicing or installing this unit. Multiple power sources may be present. Failure to do so may cause property damage, personal injury or death.

WARNING

Goodman will not be responsible for any injury or property damage arising from improper service or service procedures. If you install or perform service on this unit, you assume responsibility for any personal injury or property damage which may result. Many jurisdictions require a license to install or service heating and air conditioning equipment.

WARNING

Installation and repair of this unit should be performed ONLY by individuals meeting (at a minimum) the requirements of an "entry level technician", as specified by the Air-Conditioning, Heating, and Refrigeration Institute (AHRI). Attempting to install or repair this unit without such background may result in product damage, personal injury or death.

PRODUCT IDENTIFICATION

The model number is used for positive identification of component parts used in manufacturing. Please use this number when requesting service or parts information.

AVPTC24B14A*
AVPTC30C14A*
AVPTC36C14A*
AVPTC48C14A*
AVPTC42D14A*
AVPTC48D14A*
AVPTC60D14A*

WARNING

The United States Environmental Protection Agency (“EPA”) has issued various regulations regarding the introduction and disposal of refrigerants introduced into this unit. Failure to follow these regulations may harm the environment and can lead to the imposition of substantial fines. These regulations may vary by jurisdiction. Should questions arise, contact your local EPA office.

WARNING

Do not connect or use any device that is not design certified by Goodman for use with this unit. Serious property damage, personal injury, reduced unit performance and/or hazardous conditions may result from the use of such non-approved devices.

WARNING

To prevent the risk of property damage, personal injury, or death, do not store combustible materials or use gasoline or other flammable liquids or vapors in the vicinity of this appliance.

WARNING

When installing or servicing this equipment, safety clothing, including hand and eye protection, is strongly advised. If installing this equipment in an area that has special safety requirements (hard hats etc.), observe these requirements. To protect the unit when brazing close to the painted surfaces, the use of a quenching cloth is strongly advised to prevent scorching or marring of the equipment finish.

WARNING

The unit **MUST** have an uninterrupted, unbroken electrical ground to minimize the possibility of personal injury if an electrical fault should occur. The electrical ground circuit may consist of an appropriately sized electrical wire connecting the ground lug in the unit control box to the building electrical service panel. Other methods of grounding are permitted if performed in accordance with the “National Electric Code” (NEC)/“American National Standards Institute” (ANSI)/“National Fire Protection Association” (NFPA) 70 and local/state codes. In Canada, electrical grounding is to be in accordance with the Canadian Electric Code CSA C22.1. Failure to observe this warning can result in electrical shock that can cause personal injury or death.

PRODUCT DESIGN

WARNING If this appliance is installed in an enclosed area such as a garage or utility room with any carbon monoxide (CO) producing appliance (i.e. automobile, furnace, water-heaters, etc.), ensure the area is properly ventilated.

WARNING HIGH VOLTAGE
Disconnect ALL power before servicing or installing this unit. Multiple power sources may be present. Failure to do so may cause property damage, personal injury or death.



AIR HANDLERS

See Air Handler Specification Sheet for Proper Combinations.

**ALL AIR HANDLERS USE DIRECT DRIVE MOTORS.
POWER SUPPLY IS 208-230 V, 60 HZ, 1 PHASE.**

Installation

Before installing this appliance insure that it is properly sized and adequate power is available.

This appliance can be installed in the vertical or right horizontal position without modification. The horizontal left and downflow positions require product modification.

This product is designed for zero inches (0 inches) clearance; however, adequate access for service or replacement must be considered without removing permanent structure. This unit can be installed on a platform when deemed necessary.

In an attic installation a secondary drain pan must be provided by the installer and placed under the entire unit with a separate drain line properly sloped and terminated in an area visible to the owner. This secondary drain pan is required in the event that there is a leak or main drain blockage. Closed cell insulation should be applied to the drain lines in unconditioned spaces where sweating may occur.

Appliances installed in garages, warehouses or other areas where they may be subjected to mechanical damage must be suitably guarded against such damage by installing behind protective barriers, being elevated or located out of the normal path of vehicles. When installed on a base, the base must also be protected by similar means.

Heating and cooling equipment located in garages, which may generate a glow, spark or flame capable of igniting flammable vapors, must be installed with the ignition source at least 18"[46cm] above the floor level.

When more than one appliance is installed in a building it shall be permanently identified as to the area or space serviced by the equipment.

When this product is installed in the downflow installation in an unconditioned space, remove the horizontal drain pan and install the following insulation kit.

MODEL LIST FOR DOWNFLOW KITS

DFK-B Downflow Kit	DFK-C Downflow Kit	DFK-D Downflow Kit
AVPTC24B14**	AVPTC30C14**	AVPTC42D14**
	AVPTC36C14**	AVPTC48D14**
	AVPTC48C14**	AVPTC60D14**

This kit is used to prevent sweating on the vertical drain pan.

*AVPTC is a multi-position, variable-speed air handler and is used with R-410A. The unit's blower design includes a variable-speed ECM motor and is compatible with heat pumps and variable-capacity cooling applications.

AVPTC air handlers are available in 2 to 5 ton sizes with optional 3 kW to 25kW electric heat kits available for field installation. (See note below.)

NOTE: Factory-sealed to achieve a 2% or less leakage rate at 1.0" water gauge external duct static pressure.

Complies with the Factory-sealed Air Handling Credit as listed in the 2001 Florida Building Code, Chapter 13, Section 610.2.A.2.1.

PRODUCT DIMENSIONS

AVPTC

Model	A	B	C	D	E	F	G	H
AVPTC24B14*	45	16 ³ / ₈	17 ¹ / ₂	18	15	14 ³ / ₁₆	8 ¹³ / ₁₆	11 ¹⁵ / ₁₆
AVPTC30C14*	49	19 ¹⁵ / ₁₆	21	20	17	17 ¹¹ / ₁₆	10 ¹ / ₂	12 ³ / ₈
AVPTC36C14*	49	19 ¹⁵ / ₁₆	21	20	17	17 ¹¹ / ₁₆	10 ¹ / ₂	12 ³ / ₈
AVPTC48C14*	49	19 ¹⁵ / ₁₆	21	20	17	17 ¹¹ / ₁₆	10 ¹ / ₂	12 ³ / ₈
AVPTC42D14*	58	23 ⁵ / ₁₆	24 ¹ / ₂	28 ³ / ₁₆	25 ³ / ₁₆	21 ³ / ₁₆	12 ⁵ / ₁₆	12 ³ / ₈
AVPTC48D14*	58	23 ⁵ / ₁₆	24 ¹ / ₂	28 ³ / ₁₆	25 ³ / ₁₆	21 ³ / ₁₆	12 ⁵ / ₁₆	12 ³ / ₈
AVPTC60D14*	58	23 ⁵ / ₁₆	24 ¹ / ₂	28 ³ / ₁₆	25 ³ / ₁₆	21 ³ / ₁₆	12 ⁵ / ₁₆	12 ³ / ₈

PRODUCT SPECIFICATIONS

	AVPTC 24B14*	AVPTC 30C14*	AVPTC 36C14*	AVPTC 48C14A*	AVPTC 42D14*	AVPTC 48D14*	AVPTC 60D14*
Nominal Ratings							
Cooling (Btu/h)	24,000	30,000	36,000	42,000	42,000	48,000	60,000
CFM (High range)	1100/600	1200/600	1600/700	1660/700	1700/800	1800/1350	2000/1600
Blower							
Diameter	10 ⁵ / ₈ "	10 ⁵ / ₈ "	10 ⁵ / ₈ "	10 ⁵ / ₈ "	10 ⁵ / ₈ "	10 ⁵ / ₈ "	11 ⁵ / ₈ "
Width	6"	8"	10 ⁵ / ₈ "	10 ⁵ / ₈ "	10 ⁵ / ₈ "	10 ⁵ / ₈ "	10 ⁵ / ₈ "
Coil Drain Connect FPT	³ / ₄ "	³ / ₄ "	³ / ₄ "	³ / ₄ "	³ / ₄ "	³ / ₄ "	³ / ₄ "
Refrigerant Line Connection Size							
Liquid	³ / ₈ "	³ / ₈ "	³ / ₈ "	³ / ₈ "	³ / ₈ "	³ / ₈ "	³ / ₈ "
Suction	³ / ₄ "	⁷ / ₈ "	⁷ / ₈ "	⁷ / ₈ "	⁷ / ₈ "	⁷ / ₈ "	⁷ / ₈ "
Electrical Data							
Voltage	208/240	208/240	208/240	208/240	208/240	208/240	208/240
Electric Heat Capacity (kW)	3, 5, 6, 8, 10	3, 5, 6, 8, 10	5, 6, 8, 10, 15, 19	5, 6, 8, 10, 15, 19, 20F	5, 6, 8, 10, 15, 20	5, 6, 8, 10, 15, 20, 25	5, 6, 8, 10, 15, 20, 25
Min Circuit Ampacity	4.9/4.9	4.9/4.9	6.5/6.5	6.5/6.5	6.5/6.5	6.5/6.5	8.6/8.6
Max. Overcurrent Device (amps)	15/15	15/15	15/15	15/15	15/15	15/15	15/15
Minimum VAC	197	197	197	197	197	197	197
Maximum VAC	253	253	253	253	253	253	253
Blower Motor							
FLA	3.9	3.9	5.2	5.2	5.2	5.2	6.9
HP	¹ / ₂	¹ / ₂	³ / ₄	³ / ₄	³ / ₄	³ / ₄	1
Ship Weight (lbs)	100	118	118	125	155	167	167

*Airflow rate @.3 static

BLOWER PERFORMANCE DATA

Speed Selection Dip Switches								
TAP	Cool Selection Switches		Adjust Selection Switches		Profile Selection Switches		Continuous Fan Speed	
	S1	S2	S3	S4	S5	S6	S12	S13
A	OFF	OFF	OFF	OFF	OFF	OFF	OFF	OFF
B	ON	OFF	ON	OFF	ON	OFF	ON	OFF
C	OFF	ON	OFF	ON	OFF	ON	OFF	ON
D	ON	ON	ON	ON	ON	ON	ON	ON
Profiles	Pre-Run		Short-Run		OFF Delay			
A	-----		-----		60 sec/100%			
B	-----		30 sec/50%		60 sec/100%			
C	-----		7.5 min/82%		60 sec/100%			
D	30 sec/50%		7.5 min/82%		30 sec/50%			
<p>To set Airflow: (1) Select model and desired High Stage Cooling Airflow. Determine the corresponding tap (A, B, C, D). Set dip switches S1 and S2 to the appropriate ON / OFF positions. (2) Select model and installed electric heater size. Set dip switches S9, S10, and S11 to the appropriate ON / OFF positions. (3) If airflow adjustment is required set Trim Enable Switch S8 to ON (OFF = 0% Trim) and set S3 and S4 to appropriate ON / OFF positions. Tap A is +5%, Tap B is -5%, Tap C is +10%, Tap D is -10%.</p> <p>To Set Comfort mode: Select desired Comfort Mode Profile (see profiles above). Set dip switches S5 and S6 to appropriate ON / OFF positions.</p> <p>Dehumidification: To enable, set dip switch S7 to ON. Cooling airflow will be reduced to 85% of nominal value during cool call when Dehum command is present. To disable, set S7 to OFF.</p> <p>Continuous Fan Speed: Use dip switches S12 and S13 to select one of 4 continuous fan speeds, Tap A is 25%. Tap B is 50%, Tap C is 75%, Tap D is 100%.</p> <p>Notes:</p> <ol style="list-style-type: none"> Airflow data shown applies to legacy mode operation only. For a fully communicating system, please see the outdoor unit's installation instructions for cooling and heat pump airflow data. See <i>ComfortNet System-Airflow Consideration section for details.</i> Airflow blink codes are approximations of actual airflow. 								

Cooling/Heat Pump Airflow Table			
Model	Speed tap	Low stage (CFM)	High stage (CFM)
AVPTC24B14**	A	410	610
	B	565	835
	C	660	970
	D	765	1125
AVPTC30C14**	A	440	610
	B	605	835
	C	740	1020
	D	885	1225
AVPTC36C14**	A	500	725
	B	700	1000
	C	930	1330
	D	1120	1600
AVPTC48C14**	A	500	725
	B	700	1000
	C	930	1330
	D	1120	1600
AVPTC42D14**	A	560	800
	B	763	1090
	C	994	1420
	D	1225	1750
AVPTC48D14**	A	900	1350
	B	1035	1550
	C	1140	1700
	D	1200	1800
AVPTC60D14**	A	1210	1610
	B	1365	1815
	C	1450	1920
	D	1525	2025

HEAT KIT INFORMATION

AVPTC

ELECTRIC HEAT AIRFLOW TABLE

Htr kW	9	10	11	AVPTC24B14A*	AVPTC30C14A*	AVPTC36C14A*	AVPTC48C14*	AVPTC42D14A* †	AVPTC48D14A* ††	AVPTC60D14A* †††
3	ON	ON	ON	550	600	NR	NR	850**	NR	NR
5	ON	ON	OFF	650	700	850	850	1250	1250	1250
6	ON	OFF	ON	700	750	900	900	1300	1300	1300
8	ON	OFF	OFF	800	875	1000	1000	1500	1500	1500
10	OFF	ON	ON	850	950	1200	1200	1550	1550	1750
15	OFF	ON	OFF	NR	NR	1440	1440	1720	1720	1780
19*	OFF	OFF	ON	NR	NR	1500	1500	NR	NR	NR
20				NR	NR	1500	1500	1800	1815	1850
21 or 25*	OFF	OFF	OFF	NR	NR	NR	NR	NR	1850	1850

Note: Airflow data shown applies to the electric heat only in either legacy mode or communicating mode operation

NR - Not rated

* Within thermostat user menu CTK0* communicating thermostat will display 20KW for OFF- OFF- ON dip switch selection, 21KW for OFF-OFF-OFF dip switch selection

* For match up with a 2 ton outdoor unit: Heater kit application shall not exceed 10 kW. Airflow for 5 kW up to 10 kW heater kits shall be set to 850 cfm speed tap of ON-ON-ON.

** For match up with a 3 ton outdoor unit: Heater kit application shall not exceed 15 kW. Airflow for 5 kW up to 15 kW heater kits shall be set to 1300 cfm speed tap of ON-OFF-ON.

*** For match up with a 3.5 ton outdoor unit: Heater kit application shall not exceed 20 kW. Airflow for 5 kW up to 20 kW heater kits shall be set to 1500 cfm speed tap of ON-OFF-OFF

** 3 kW heater kit is not applicable for this indoor application.

Heat Kit Selection

Models	HKX03XC	HKX05XC	HKX06XC	HKX08XC	HKX10XC	HKX15XF*	HKX20XF*	HKC05XC	HKC08XC	HKC10XC	HKC15XA	HKC15XB	HKC15XF	HKC19CA	HKC19CB	HKC20DA	HKC20DB	HKC20XF*	HKC25XF	HKC25DC
AVPTC24B14A*	X	X	X	X	X			X	X	X										
AVPTC30C14A*	X	X	X	X	X			X	X	X										
AVPTC36C14A*		X	X	X	X	X	X	X	X	X	X	X	X	X	X			X	X	
AVPTC48C14A*		X	X	X	X	X	X	X	X	X	X	X	X	X	X			X	X	
AVPTC42D14A*		X	X	X	X	X	X	X	X	X	X	X	X			X	X	X	X	
AVPTC48D14A*		X	X	X	X	X	X	X	X	X	X	X	X			X	X	X	X	X
AVPTC60D14A*		X	X	X	X	X	X	X	X	X	X	X	X			X	X	X	X	X

* Revision level that may or may not be designated.

C Circuit breaker option.

WARNING

HIGH VOLTAGE!
DISCONNECT ALL POWER BEFORE SERVICING OR INSTALLING THIS UNIT. MULTIPLE POWER SOURCES MAY BE PRESENT. FAILURE TO DO SO MAY CAUSE PROPERTY DAMAGE, PERSONAL INJURY OR DEATH.

3-Phase Heat Kit

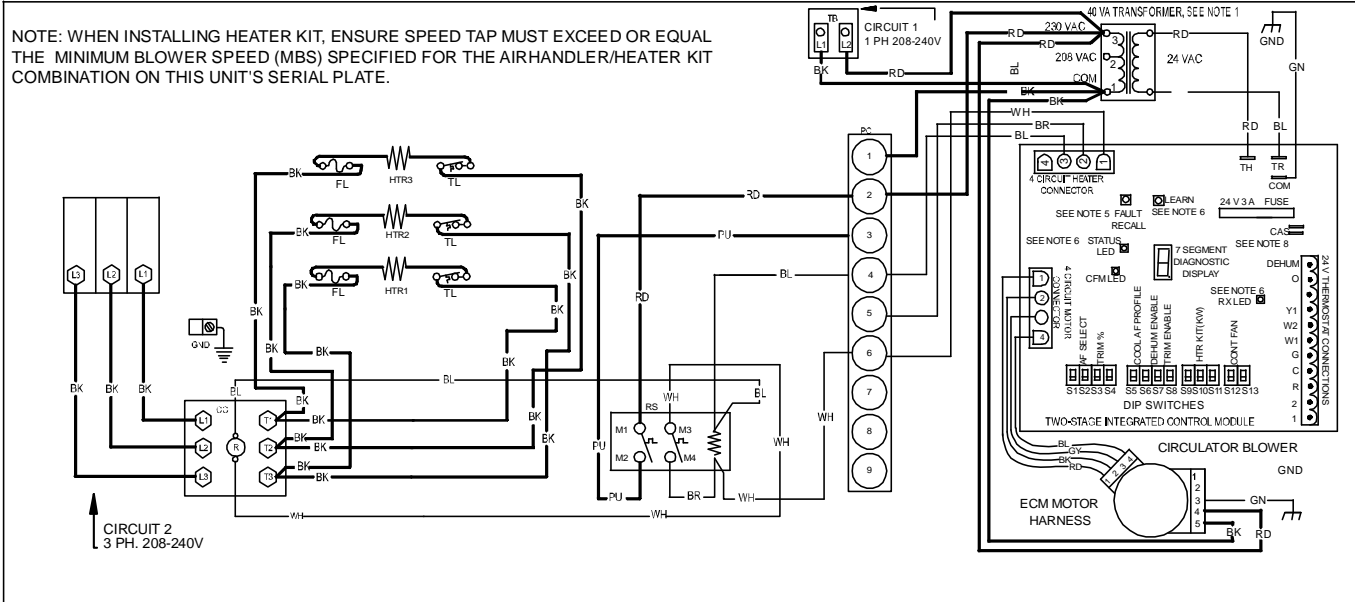

25kW Heat Kit

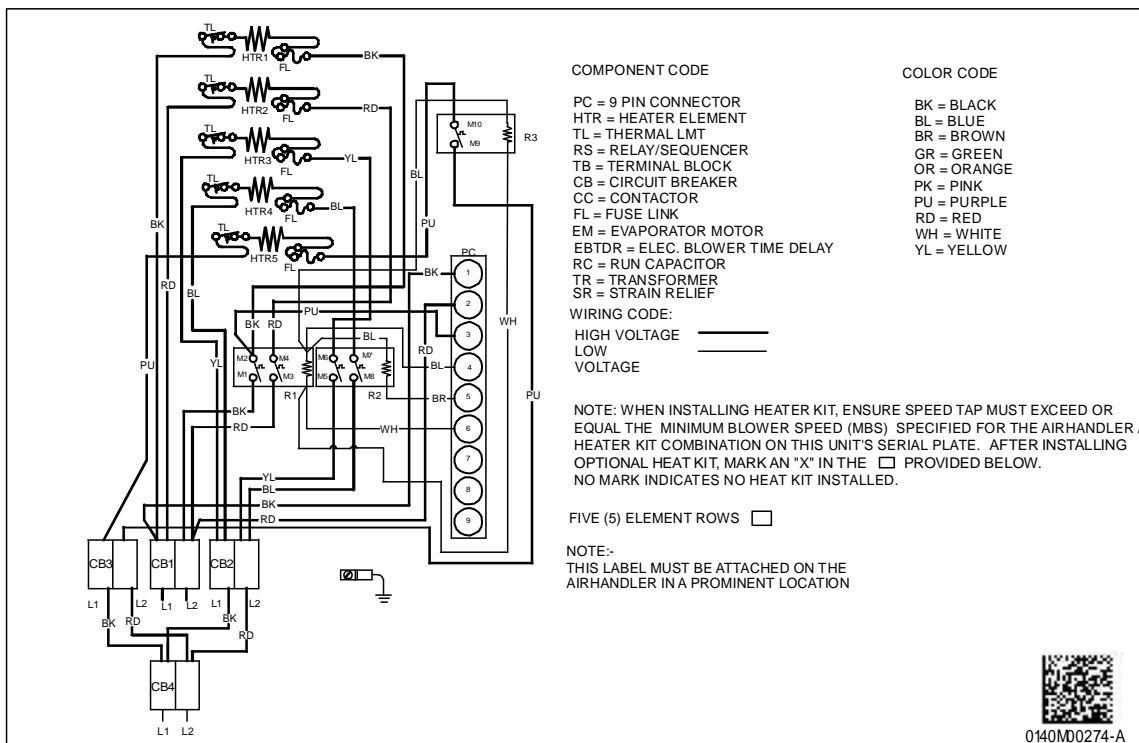

Wiring is subject to change. Always refer to the wiring diagram on the unit for the most up-to-date wiring.