

# PRODUCT INFORMATION PACKET



Model No: FE1026SU  
Catalog No: FE1026SU  
1/4 HP Condenser Fan Motor, 1075 RPM, 208-230 Volts, 48 Frame, TEAO  
Condenser Fans Motors



Regal and Century are trademarks of Regal Beloit Corporation or one of its affiliated companies.  
©2020 Regal Beloit Corporation, All Rights Reserved. MC017097E





**Nameplate Specifications**

Output HP	1/4 Hp	Output KW	0.19 kW
Frequency	60 Hz	Voltage	208-230 V
Current	1.9 A	Speed	1075 rpm
Service Factor	1	Phase	1
Duty	Air Over	Insulation Class	F
Frame	48	Enclosure	Totally Enclosed
Thermal Protection	Automatic	Ambient Temperature	80 °C
UL	Recognized	CSA	Y
CE	N		

**Technical Specifications**

Electrical Type	Permanent Split Capacitor	Starting Method	Across The Line
Poles	6	Rotation	Reversible
Mounting	Extended Studs	Motor Orientation	Any
Drive End Bearing	Ball	Opp Drive End Bearing	Ball
Frame Material	Rolled Steel	Shaft Type	Double Flat
Overall Length	11.74 in	Frame Length	3.75 in
Shaft Diameter	0.500 in	Shaft Extension	6.5 in
Connection Drawing	614131-242	Outline Drawing	FE1026SU-S01

This is an uncontrolled document once printed or downloaded and is subject to change without notice. Date Created:22/09/2020

GENERAL INFORMATION:

SHAFT RUNOUT: .001 [.03] T.I.R. PER INCH LENGTH OF EXTENSION

BEARINGS: BALL

MOUNTING POSITION: ALL ANGLE

ELECTRICAL DATA:

OVERLOAD PROTECTOR: AUTOMATIC RESET (T.I. 7AM 304)

LINE LEADS: NO. 18 GA., .06 [1.5] THK. XLP 125°C INSUL.

REVERSING PLUGS: NO. 18 GA., .03 [.8] THK. XLP 125°C INSUL.

GROUND LEAD: NO. 18 GA., .03 [.8] THK. (GREEN) INSUL.

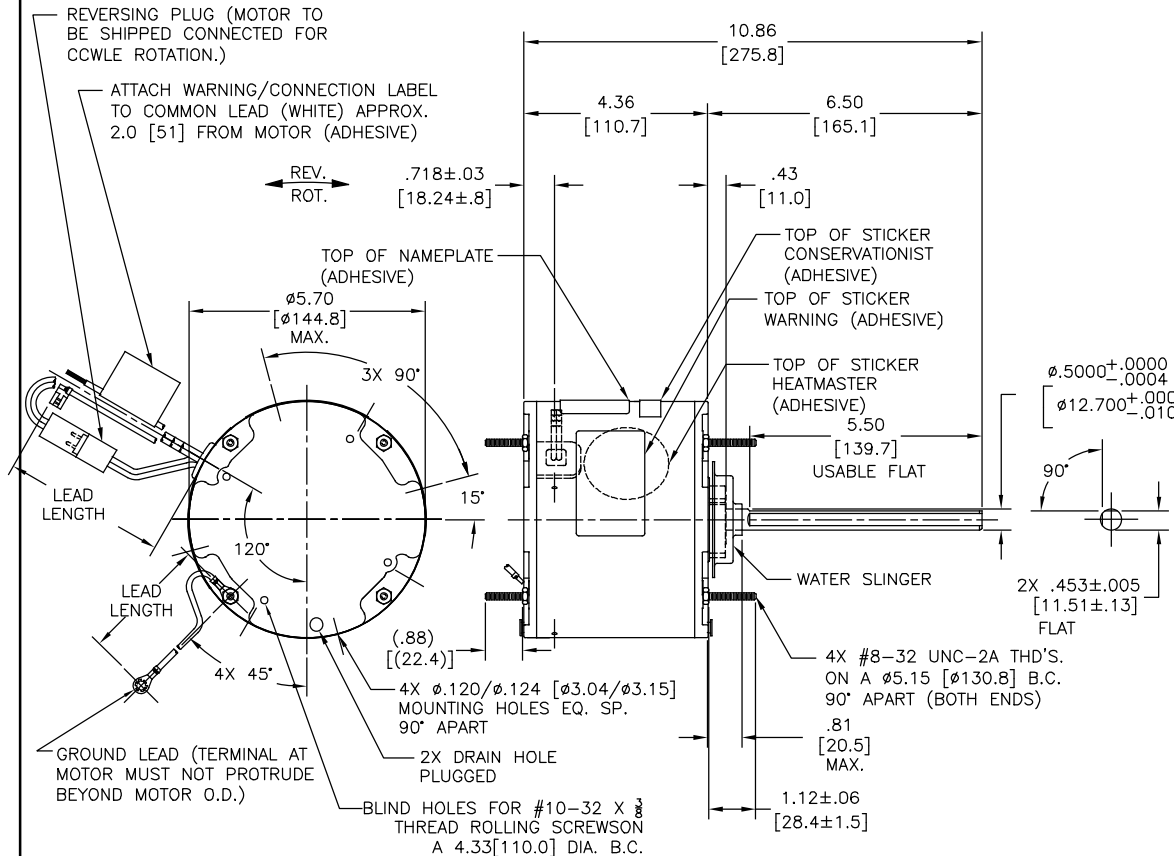

- NOTES:
- ATTACH INSTRUCTION SHEET 69P9-3 ONTO SHAFT APPROX. 1.0[25] FROM WATER SLINGER
  - 4X SCREWS 615982-001 & 4X HEX NUTS 7555A19H01 & 4X SCREWS 13833003 TO BE PUT IN A POLYBAG.

NAMEPLATE DATA:	EXTERNAL CONNECTION DIAGRAM
MODEL NO.: F48AF25A01 CUST. P/N: FE1026SU HP: 1/4 ROT.: REVERSIBLE RPM: 1075 TYPE: UF FRAME: 48 VOLTS: 208-230 PH: 1 AMPS: 1.9 HZ: 60 INS.: F AMB.: 80°C DUTY: AIR OVER CAP.: 5 MFD/370 V ENCL: ENCLOSED UL LOGO CSA LOGO THERMALLY PROTECTED	SEP. CAP. BROWN BRN/WHT WHITE BLACK LINE ROTATION BLACK BLACK WHITE WHITE BLACK CCWLE WHITE WHITE CWLE BLACK 614131-242

PERFORMANCE CURVE NO.	TORQUE @ 1075 RPM (25°C)	APPROVED SAMPLE	UL COMPONENT	CSA
FILE #	CCN #	FILE #	CLASS #	
C32508	28.6 OZ. FT.	0500463A	E46412 PRGY2	LR43341 4211-01

COLOR	LENGTH	TERMINAL OR STRIP LENGTH
GREEN (GROUND)	12.0/13.0 [305/330]	#10 EYELET
BLACK/WHITE	3.0/5.0 [76/127]	REVERSING PLUG
BROWN	48.0/51.0 [1219/1295]	.25 [6.4] FLAG
BROWN/WHITE	48.0/51.0 [1219/1295]	.25 [6.4] FLAG
WHITE	48.0/51.0 [1219/1295]	.50 [12.7] SKIN
BLACK	48.0/51.0 [1219/1295]	.50 [12.7] SKIN

REGAL-BELOIT CORPORATION (RBC) PROVIDES TECHNICAL ASSISTANCE TO OUR CUSTOMERS IN SEVERAL AREAS. SINCE RBC DOES NOT RECEIVE ALL DATA CONCERNING THE USE AND APPLICATION OF THE MOTOR, THE SUITABILITY OF THE MOTOR FOR THE APPLICATION MUST BE DETERMINED BY THE CUSTOMER.

DIMENSIONS WITHOUT TOLERANCES ARE FOR REFERENCE ONLY.

MAIN FRAME - OLE	ENCLOSED
END FRAME - OLE	ENCLOSED
MAIN FRAME - LE	ENCLOSED
END FRAME - LE	ENCLOSED

FILE #	CCN #	FILE #	CLASS #
E46412	PRGY2	LR43341	4211-01

DRAWING REVISION	REVISION BY	DATE
D	GELINE ZHAO	05-23-2019
ECO	KEYUN QONG	05-23-2019
ECO-0166568		
SEE ECO		

REGAL-BELOIT CORPORATION, INC. ALL RIGHTS RESERVED. PROPRIETARY AND CONFIDENTIAL INFORMATION - THIS DOCUMENT IS THE PROPERTY OF REGAL-BELOIT CORPORATION, INC. AND/OR ANY PART OF IT. IT SHALL NOT BE DISCLOSED, REPRODUCED, COPIED, OR TRANSMITTED IN ANY FORM OR BY ANY MEANS, ELECTRONIC OR MECHANICAL, INCLUDING PHOTOCOPYING, RECORDING, OR BY ANY INFORMATION STORAGE AND RETRIEVAL SYSTEM, WITHOUT THE WRITTEN PERMISSION OF REGAL-BELOIT CORPORATION, INC. THIS DOCUMENT SHALL BE RETURNED TO OWNER UPON REQUEST. IT MAY BE SUBJECT TO CERTAIN RESTRICTIONS UNDER APPLICABLE EXPORT CONTROL LAWS AND REGULATIONS.

DRAWN BY: A.SUN	DATE: 01-24-2013	APPROVED BY: ME.HE	DATE: 01-24-2013	PROCESS/FINISH	THIRD ANGLE PROJECTION	SIZE DWG NO: C	FE1026SU	SHEET 1
REGAL-BELOIT CORPORATION, Inc.		DESCRIPTION: OUTLINE		MATERIAL				

4

3

2

1

REV	ECO	REV BY	DATE	APPD	DATE
D	0029048	D.RODRIGUEZ	10-18-2012	J.HESS	10-18-2012

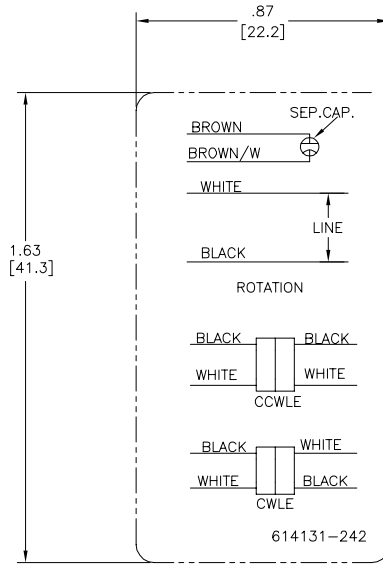

- NOTES:  
 1. FOR USE WITH 614129 OR 2513020-001 NAMEPLATE BLANKS  
 2. ----- INDICATES DIMENSION LIMITS

GEOMETRIC CHARACTERISTICS & SYMBOLS	
▭	FLATNESS
—	STRAIGHTNESS
∠	ANGULARITY
⊥	PERPENDICULARITY (SQUARENESS)
∥	PARALLELISM
○	ROUNDNESS (CIRCULARITY)
⊘	CYLINDRICITY
△	PROFILE OF ANY SURFACE
∩	PROFILE OF ANY LINE
⌀	RUNOUT
⊕	TRUE POSITION
◎	CONCENTRICITY
⊖	SYMMETRY

ASME Y14.5M 1994

UNLESS OTHERWISE SPECIFIED DIM. TOLERANCES ARE AS FOLLOWS:
INCH X XX XXX XXXX
±.1 ±.02 ±.005 ±.0005
mm ±0.5 ±0.13 ±0.013
ANG. ±.50 DEG
REMOVE BURRS & BREAK SHARP EDGES:
INCH .003-.015 mm 0.1-.04
CORNER FILLETS TO:
INCH .020 mm 0.5
MACHINE SURFACES:
INCH 125 mm 3.2
METRIC DIMS. SHOWN IN [BRACKETS]

DR BY:	YL	04-15-2011
APPD:	HZ	04-15-2011
THIRD ANGLE PROJECTION		EDS DATE 11-11-2011 FORMAT REV H
CONFIDENTIAL: THIS DRAWING AND ITS INFORMATION ARE THE EXCLUSIVE AND CONFIDENTIAL PROPERTY OF REGAL-BELOIT CORPORATION AND ARE NOT TO BE DISCLOSED, DUPLICATED, DISTRIBUTED OR OTHERWISE USED WITHOUT THE WRITTEN CONSENT OF REGAL-BELOIT CORPORATION. -ALL RIGHTS RESERVED.		

<b>REGAL-BELOIT CORPORATION</b>	
DESCRIPTION CONN DIAGRAM-NAMEPLATE	
SIZE C	DWG NO 614131-242
SCALE NONE	SHEET 1

4

3

2

1

4

3

2

1

REVISION:	ECO	REVISADO POR:	FECHA:	APROBADO POR:	FECHA:
D	0029048	D.RODRIGUEZ	10-18-2012	J.HESS	10-18-2012



NOTAS:  
 1. PARA USO CON PLACA DE DATOS EN BLANCO. NAMEPLATE BLANKS  
 2. INDICATES DIMENSION LIMITS  
 INDICA LIMITES DE DIMENSION

CARACTERISTICAS DE GEOMETRIA Y SIMBOLOS ▽ PLANICIDAD — RECTITUD ∠ ANGULARIDAD ⊥ PERPENDICULARIDAD (A ESQUADRA) // PARALELISMO ○ REDONDEZ (CIRCULARIDAD) Ⓜ CILINDRICIDAD ⊖ PERFIL DE CUALQUIER SUPERFICIE ∩ PERFIL DE CUALQUIER LINEA † VARIACION ⊕ POSICION REAL ⊙ CONCENRICIDAD ≡ SIMETRIA	A MENOS QUE SE ESPECIFIQUE DE OTRA MANERA, LAS TOLERANCIAS DE LAS DIMS. SON LAS SIGUIENTES: PULG ±.1 ±.02 ±.005 ±.0005 mm ±0.5 ±0.13 ±0.013 ANG. ±50 GRADOS ELIMINAR REBASAS Y ORILLAS FILOSAS DEL BORDE. PULG .003-.015 mm 0.1-0.4 FILETEAR ESQUINA: PULG .020 mm 0.5 MAQUINAR SUPERFICIES PULG 125 mm 3.2 DIMS METRICAS MOSTRADAS [PARENTESIS]	DIBUJADO POR: YL	04-15-2011	<b>REGAL-BELOIT CORPORATION</b>
		APROBADO POR: HZ	04-15-2011	
		TERCER ANGULO DE PROYECCION	FECHA EDS: 11-11-2011 REV. FORMATO: H	TAMAÑO: C
		CONFIDENCIAL: ESTE DIBUJO Y SU INFORMACION SON PROPIEDAD DE USO EXCLUSIVO Y CONFIDENCIAL DE REGAL-BELOIT CORPORATION. Y NO DEBERAN SER REVELADOS, DUPLICADOS, DISTRIBUIDOS O USARSE DE OTRA MANERA SIN EL CONSENTIMIENTO ESCRITO DE REGAL-BELOIT CORPORATION. -TODOS LOS DERECHOS RESERVADOS.		NUMERO DE DIBUJO: 614131-242
		ESCALA: NONE		HOJA: 1

4

3

2

1