

PRODUCT INFORMATION PACKET



Model No: EM3459

Catalog No: EM3459

1/3-1/8 HP Condenser Fan Motor, 825 RPM, 1 Speed, 208-230 Volts, 48 Frame, TEAO
Condenser Fans Motors



Regal and Century are trademarks of Regal Beloit Corporation or one of its affiliated companies.
©2020 Regal Beloit Corporation, All Rights Reserved. MC017097E

The REGAL logo is a grey rectangular box with the word 'REGAL' in white, bold, uppercase letters. The box is tilted slightly to the right. The background of the page features a vertical blue gradient with a halftone dot pattern on the right side.

REGAL



Nameplate Specifications

Output HP	1/3-1/8 Hp	Output KW	0.25 kW
Frequency	60 Hz	Voltage	208-230 V
Current	1.8-2.0 A	Speed	825 rpm
Service Factor	1	Phase	1
Duty	Air Over	Insulation Class	B
Frame	48Y	Enclosure	Totally Enclosed
Thermal Protection	Automatic	Ambient Temperature	60 °C
UL	Recognized	CSA	Y
CE	N		

Technical Specifications

Electrical Type	Permanent Split Capacitor	Starting Method	Across The Line
Poles	8	Rotation	Reversible
Mounting	Extended Studs	Motor Orientation	Any
Drive End Bearing	Ball	Opp Drive End Bearing	Ball
Frame Material	Rolled Steel	Shaft Type	Flat
Overall Length	12.45 in	Frame Length	4.25 in
Shaft Diameter	0.500 in	Shaft Extension	6.7 in
Outline Drawing	EM3459-S01	Connection Drawing	614131-292

This is an uncontrolled document once printed or downloaded and is subject to change without notice. Date Created:22/09/2020

GENERAL INFORMATION:

SHAFT RUNOUT: .001[.03] T.I.R. PER 1.00[25.4] LENGTH OF EXTENSION

BEARINGS: BALL

MOUNTING POSITION: ALL ANGLE

ELECTRICAL DATA:

OVERLOAD PROTECTOR: AUTOMATIC RESET (SENSATA 7AM 304)

LINE LEADS: NO. 18 GA., .03[.8] THK. XLP 125°C INSUL.

REVERSING LEADS: NO. 18 GA., .03[.8] THK. XLP 125°C INSUL.

GROUND LEAD: NO. 18 GA., .03[.8] THK. (GREEN/YELLOW) INSUL.

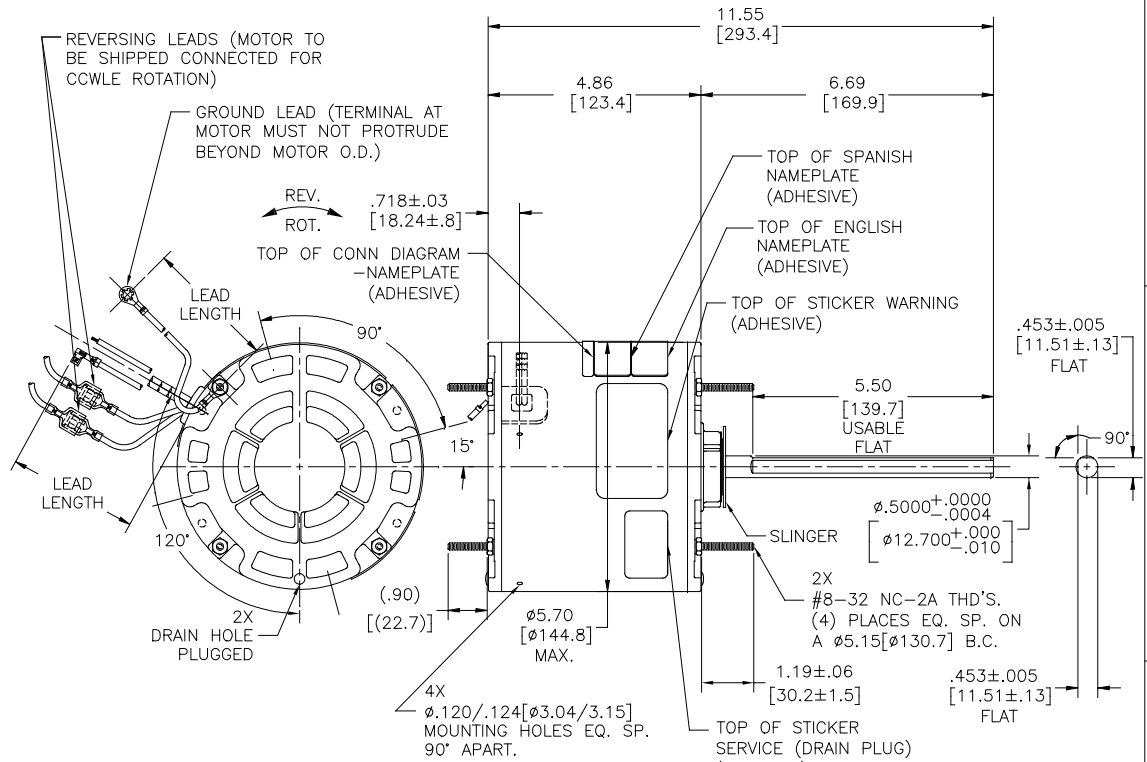

- NOTES:**
- 4X SCREWS 615982-001 & 4X HEX NUTS 7555A19H01 TO BE PUT IN A POLYBAG.
 - THE SYMBOL OF CTQ: ▲ (NO CTQ ON THIS DRAWING).
 - MEET THE REQUIREMENT OF RoHS & REACH, SEE EP000014_5.1.

REGAL-BELOIT CORPORATION (RBC) PROVIDES TECHNICAL ASSISTANCE TO OUR CUSTOMERS IN SEVERAL AREAS. SINCE RBC DOES NOT RECEIVE ALL DATA CONCERNING THE USE AND APPLICATION OF THE MOTOR, THE SUITABILITY OF THE MOTOR FOR THE APPLICATION MUST BE DETERMINED BY THE CUSTOMER.

DIMENSIONS WITHOUT TOLERANCES ARE FOR REFERENCE ONLY.

MAIN FRAME - OLE	ENCLOSED
END FRAME - OLE	ENCLOSED
MAIN FRAME - LE	ENCLOSED
END FRAME - LE	ENCLOSED

CUSTOMER EconoMaster

NAMEPLATE DATA:	EXTERNAL CONNECTION DIAGRAM
MODEL NO.: F48AE80A01 CUST. P/N: EM3459 HP: 1/3-1/8 ROT.: REVERSIBLE RPM: 825 TYPE: UF FRAME: 48Y VOLTS: 208-230 PH: 1 AMPS: 1.8-2.0 HZ: 60 INS.: B AMB.: 60°C DUTY: AIR OVER CAP.: 7.5 MFD/370 V ENCL: ENCLOSED UL LOGO CSA LOGO THERMALLY PROTECTED	

COLOR	LENGTH	TERMINAL OR STRIP LENGTH
GREEN/YELLOW (GROUND)	10.0/11.0 [254/279]	#10 EYELET
PURPLE (REV)	4.0/6.0 [102/152]	.25[6.4] PRE-INSUL. MALE TAB
PURPLE (REV)	4.0/6.0 [102/152]	.25[6.4] PRE-INSUL. FEMALE SPADE
YELLOW (REV)	4.0/6.0 [102/152]	.25[6.4] PRE-INSUL. MALE TAB
YELLOW (REV)	4.0/6.0 [102/152]	.25[6.4] PRE-INSUL. FEMALE SPADE
BROWN	48.0/51.0 [1219/1295]	.25[6.4] FLAG
BROWN/WHITE	48.0/51.0 [1219/1295]	.25[6.4] FLAG
WHITE	48.0/51.0 [1219/1295]	.50[12.7] SKIN
BLACK	48.0/51.0 [1219/1295]	.50[12.7] SKIN

PERFORMANCE CURVE NO.	TORQUE @ 825 RPM (25°C)	APPROVED SAMPLE	UL COMPONENT	CSA
C32477	38.9 OZ. FT.	0540697D	E46412 PRGY2	LR43341 4211-01

<p>LEAD DATA</p> <p>DRAWING REVISION: H ECO-0187793 SEE ECO</p> <p>REVISION BY: GELINE.ZHAO APPROVED BY: KEYUN.GONG</p> <p>DATE: 06-12-2020 DATE: 06-12-2020</p>			<p>DRAWN BY: T.ZHAO</p> <p>DATE: 10-18-2011</p> <p>APPROVED BY: T.WANG</p> <p>DATE: 10-18-2011</p> <p>PROCESS/FINISH: -</p> <p>THIRD ANGLE PROJECTION</p>	<p>ENCLOSURE</p> <p>REGAL Regal Beloit America, Inc.</p> <p>MODEL-RFHP-48FR OUTLINE</p> <p>SIZE DWG NO: EM3459</p>	<p>CUSTOMER: EconoMaster</p> <p>SHEET: 1</p>
<p>REGAL-BELOIT CORPORATION (RBC) PROVIDES TECHNICAL ASSISTANCE TO OUR CUSTOMERS IN SEVERAL AREAS. SINCE RBC DOES NOT RECEIVE ALL DATA CONCERNING THE USE AND APPLICATION OF THE MOTOR, THE SUITABILITY OF THE MOTOR FOR THE APPLICATION MUST BE DETERMINED BY THE CUSTOMER.</p> <p>DIMENSIONS WITHOUT TOLERANCES ARE FOR REFERENCE ONLY.</p>			<p>REGAL-BELOIT CORPORATION (RBC) PROVIDES TECHNICAL ASSISTANCE TO OUR CUSTOMERS IN SEVERAL AREAS. SINCE RBC DOES NOT RECEIVE ALL DATA CONCERNING THE USE AND APPLICATION OF THE MOTOR, THE SUITABILITY OF THE MOTOR FOR THE APPLICATION MUST BE DETERMINED BY THE CUSTOMER.</p> <p>DIMENSIONS WITHOUT TOLERANCES ARE FOR REFERENCE ONLY.</p>		

Uncontrolled Copy

REV	ECO	REV BY	DATE	APPD	DATE
B	ECO-0022458	jrupert	09-19-2011	jrupert	09-19-2011

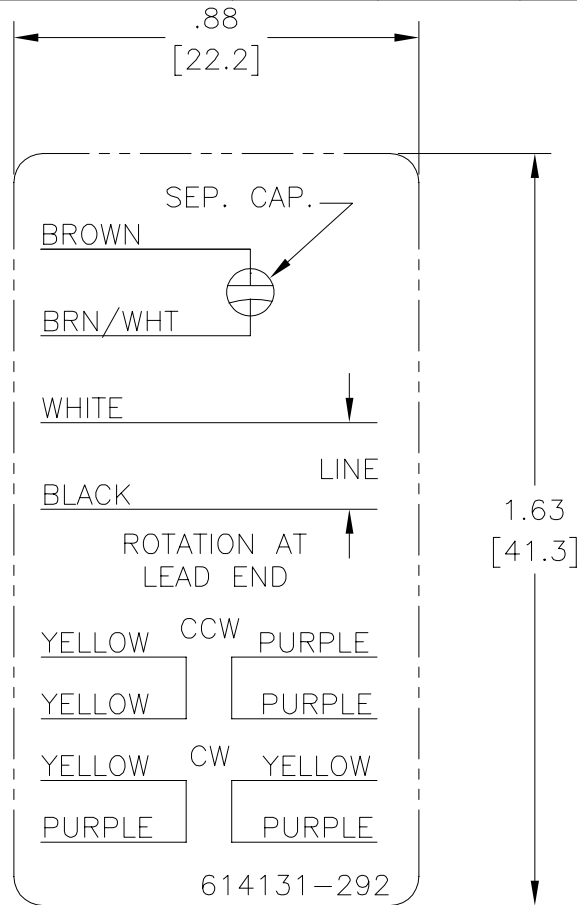

NOTES:

1. FOR USE WITH 614129 NAMEPLATE BLANK
2. — — — — — INDICATES DIMENSION LIMITS
3. DIE TO BE MADE FROM MASTER SUPPLIED BY A. O. SMITH CORPORATION
4. DIE MUST PRODUCE A LEGIBLE IMPRESSION.

GEOMETRIC CHARACTERISTICS & SYMBOLS ▽ FLATNESS — STRAIGHTNESS ∠ ANGULARITY ⊥ PERPENDICULARITY (SQUARENESS) ∥ PARALLELISM ○ ROUNDNESS (CIRCULARITY) ∅ CYLINDRICITY △ PROFILE OF ANY SURFACE ▽ PROFILE OF ANY LINE ↗ RUNOUT ⊕ TRUE POSITION ⊙ CONCENTRICITY = SYMMETRY	UNLESS OTHERWISE SPECIFIED DIM. TOLERANCES ARE AS FOLLOWS: INCH X XX XXX XXXX ±.1 ±.02 ±.005 ±.0005 mm ±0.5 ±0.13 ±0.013 ANG. ±.50 DEG REMOVE BURRS & BREAK SHARP EDGES: INCH .003-.015 mm 0.1-0.4 CORNER FILLETS TO: INCH .020 mm 0.5 MACHINE SURFACES: INCH 125 mm 3.2 METRIC DIMS. SHOWN IN [BRACKETS]	DR BY: jrupert APPD: jrupert DATE: 09-19-2011 EDS DATE 02-22-2008 FORMAT REV F THIRD ANGLE PROJECTION	DR BY: jrupert APPD: jrupert DATE: 09-19-2011 EDS DATE 02-22-2008 FORMAT REV F THIRD ANGLE PROJECTION	ELECTRICAL PRODUCTS COMPANY A DIVISION OF A. O. SMITH CORPORATION	DESCRIPTION CONN DIAGRAM NAMEPLATE SIZE A DWG NO 614131-292 SCALE NONE SHEET 1
CONFIDENTIAL: THIS DRAWING AND ITS INFORMATION ARE THE EXCLUSIVE AND CONFIDENTIAL PROPERTY OF A.O. SMITH CORP. AND ARE NOT TO BE DISCLOSED, DUPLICATED, DISTRIBUTED OR OTHERWISE USED WITHOUT THE WRITTEN CONSENT OF A.O. SMITH CORP. -ALL RIGHTS RESERVED. ASME Y14.5M 1994					

Uncontrolled Copy

REVISION:	ECO	REVISADO POR:	FECHA:	APROBADO POR:	FECHA:
B	ECO-0022458	jrupert	09-19-2011	jrupert	09-19-2011

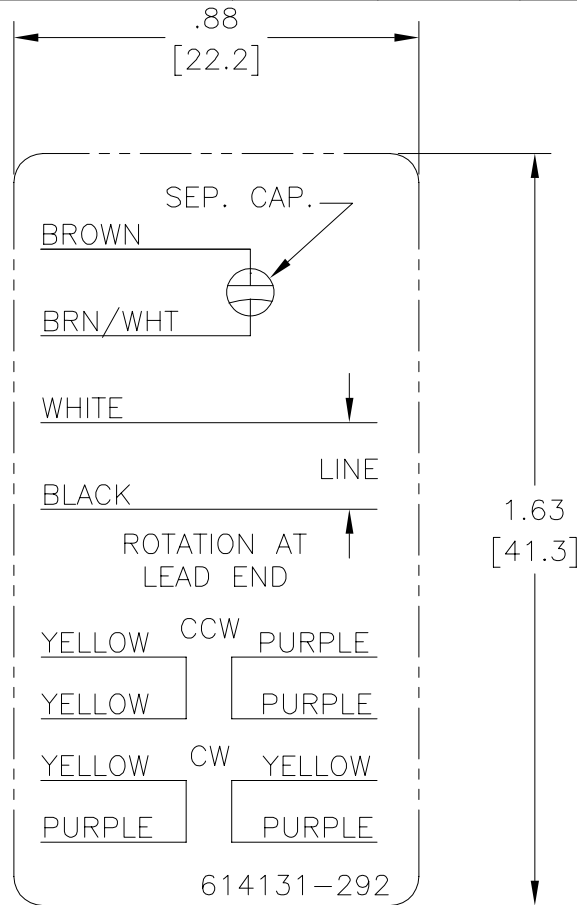

NOTES:

1. FOR USE WITH 614129 NAMEPLATE BLANK
2. — — — — — INDICATES DIMENSION LIMITS
3. DIE TO BE MADE FROM MASTER SUPPLIED BY A. O. SMITH CORPORATION
4. DIE MUST PRODUCE A LEGIBLE IMPRESSION.

CARACTERISTICAS DE GEOMETRIA Y SIMBOLOS Z PLANICIDAD — RECTITUD < ANGULARIDAD ⊥ PERPENDICULARIDAD (A ESCUADRA) // PARALELISMO ○ REDONDEZ (CIRCULARIDAD) ∅ CILINDRICIDAD △ PERFIL DE CUALQUIER SUPERFICIE ▽ PERFIL DE CUALQUIER LINEA ↗ VARIACION ⊕ POSICION REAL ⊙ CONCENTRICIDAD = SIMETRIA	A MENOS QUE SE ESPECIFIQUE DE OTRA MANERA, LAS TOLERANCIAS DE LAS DIMS. SON LAS SIGUIENTES: X XX XXX XXXX PULG ±.1 ±.02 ±.005 ±.0005 mm ±0.5 ±0.13 ±0.013 ANG. ±.50 GRADOS ELIMINAR REBABAS Y ORILLAS FILOSAS DEL BORDE. PULG .003-.015 mm 0.1-0.4 FILETEAR ESQUINA: PULG .020 mm 0.5 MAQUINAR SUPERFICIES PULG 125 mm 3.2 DIMS METRICAS MOSTRADAS [PARENTESIS]	DIBUJADO POR: jrupert 09-19-2011 APROBADO POR: jrupert 09-19-2011 TERCER ANGULO DE PROYECCION FECHA EDS: 02-22-2008 REV. FORMATO: F	ELECTRICAL PRODUCTS COMPANY <small>A DIVISION OF A. O. SMITH CORPORATION</small>	DESCRIPCION: <h2 style="text-align: center;">CONN DIAGRAM NAMEPLATE</h2>
	CONFIDENCIAL: ESTE DIBUJO Y SU INFORMACION SON PROPIEDAD DE USO EXCLUSIVO Y CONFIDENCIAL DE A.O.SMITH CORP. Y NO DEBERAN SER REVELADOS, DUPLICADOS, DISTRIBUIDOS O USARSE DE OTRA MANERA SIN EL CONSENTIMIENTO ESCRITO DE A.O. SMITH CORP. -TODOS LOS DERECHOS RESERVADOS.ASME Y14.5M 1994		TAMAÑO: A NUMERO DE DIBUJO: 614131-292	
	ESCALA: NONE		HOJA: 1	
	(Empty space)		(Empty space)	

Uncontrolled Copy

版本	ECO	编制	日期	批准	日期
B	ECO-0022458	jrupert	09-19-2011	jrupert	09-19-2011

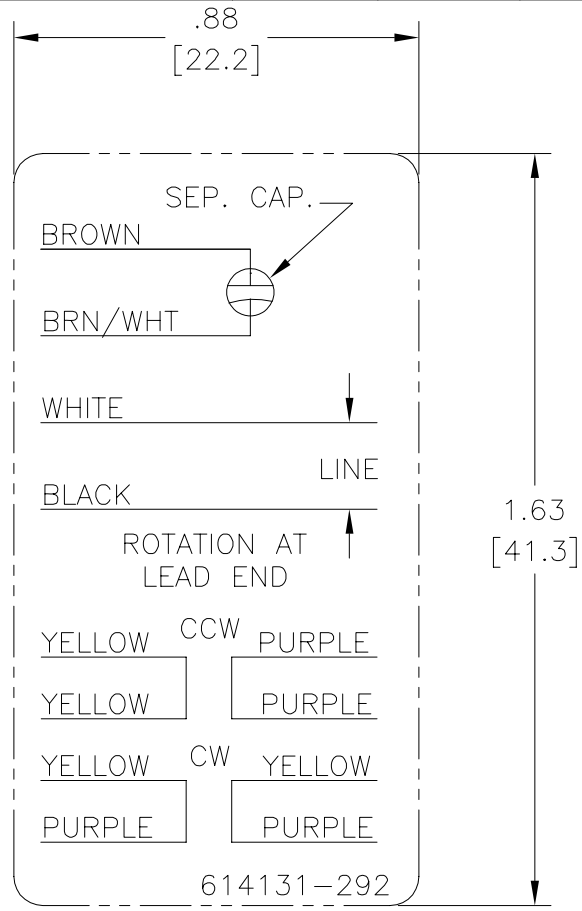

NOTES:

1. FOR USE WITH 614129 NAMEPLATE BLANK
2. — — — — — INDICATES DIMENSION LIMITS
3. DIE TO BE MADE FROM MASTER SUPPLIED BY A. O. SMITH CORPORATION
4. DIE MUST PRODUCE A LEGIBLE IMPRESSION.

形位公差 ▽ 平面度 — 直线度 ∠ 倾斜度 ⊥ 垂直度 ∥ 平行度 ○ 圆度 ⊙ 圆柱度 面轮廓度 线轮廓度 圆跳动 位置度 同轴度 ≡ 对称度	除另有注明 尺寸公差如下： 英寸 X XX XXX XXXX 毫米 ±.1 ±.02 ±.005 ±.0005 毫米 ±0.5 ±0.13 ±0.013 角度 ±.50 度 清理毛刺和尖棱 英寸 .003-.015 毫米 0.1-0.4 内圆角 英寸 .020 毫米 0.5 表面粗糙度 英制 125 米制 3.2 米制尺寸显示在 []	绘图: jrupert 批准: jrupert 第三角投影	09-19-2011 09-19-2011 图纸格式发布日期 02-22-2008 图纸格式版本 F	<p>ELECTRICAL PRODUCTS COMPANY A DIVISION OF A. O. SMITH CORPORATION</p>
	名称: CONN DIAGRAM NAMEPLATE			
	图幅: A		图号: 614131-292	
	比例: NONE		页号: 1	

ASME Y14.5M 1994