

PRODUCT INFORMATION PACKET

FASCO®

Model No: D729

Catalog No: D729

3/4-1/2-1/3 HP Fan & Blower Motor, 1075 RPM, 3 Speed, 208/230 Volts, 48 Frame, Semi Enclosed Direct Drive Motors



Regal and Fasco are trademarks of Regal Beloit Corporation or one of its affiliated companies.
©2020 Regal Beloit Corporation, All Rights Reserved. MC017097E

REGAL



Nameplate Specifications

Output HP	3/4-1/2-1/3 Hp	Output KW	0.56 kW
Frequency	60 Hz	Voltage	208-230 V
Current	5.4-3.8-2.9 A	Speed	1075 rpm
Service Factor	1	Phase	1
Duty	Continuous	Insulation Class	B
Frame	48	Enclosure	Open Drip Proof
Thermal Protection	Automatic	Ambient Temperature	40 °C
UL	Recognized	CSA	Y
CE	N		

Technical Specifications

Electrical Type	Permanent Split Capacitor	Starting Method	Across The Line
Poles	6	Rotation	Reversible
Mounting	Extended Studs	Drive End Bearing	Sleeve
Opp Drive End Bearing	Sleeve	Frame Material	Rolled Steel
Shaft Type	Double Flat	Frame Length	5.51 in
Shaft Diameter	0.500 in	Shaft Extension	6 in
Outline Drawing	8857QVS-A13U		

This is an uncontrolled document once printed or downloaded and is subject to change without notice. Date Created:22/09/2020

MOTOR SPECIFICATION

8857QVS-A13U

Q.R. No.	Y005174	CUSTOMER NO.	D729					
CUSTOMER	FASCO USA							
MOTOR RATING	VOLTS	208/230	Hz	60	Ph	1	Duty	S1 AOM
	RPM.	1075/3SP			5.4		AMPS	
NOM. OUTPUT	707 WATTS (3/4 HP)							
ROTATION	REVERSIBLE							
CAPACITOR	START	-----	μF/V	RUN	10/---	μF/V		
ENCLOSURE	DRIPPROOF							
MOTOR TYPE	PSC	INSULATION CLASS	130 (B)					
THERMAL PROTECTION	AUTO RESET OVERLOAD							
APPLICATION	FAN AXIAL - SHAFT HORIZONTAL							
BEARING D.E.	SLEEVE	LUBRICATION	PERMAWICK			OPERA.TEMP	-15°-90°C	
BEARING N.D.E.	SLEEVE							
SUPPLY LEAD	AS SHOWN							
EARTH PROVISION	SUPPLIED							
BASIC BUILD SPECIFICATION	305-881-29	PAINT/ COLOUR	PC GREY			PLAIN E/SHIELDS		
PERFORMANCE SPECIFICATION	SP88031-01							
CONNECTION DIAGRAM	AS SHOWN	RATING LABEL	AS SHOWN					

FINAL INSPECTED MOTORS MUST COMPLY WITH ELECTRIC MOTOR VIBRATION SPECIFICATION (ES049)

THIRD ANGLE PROJECTION

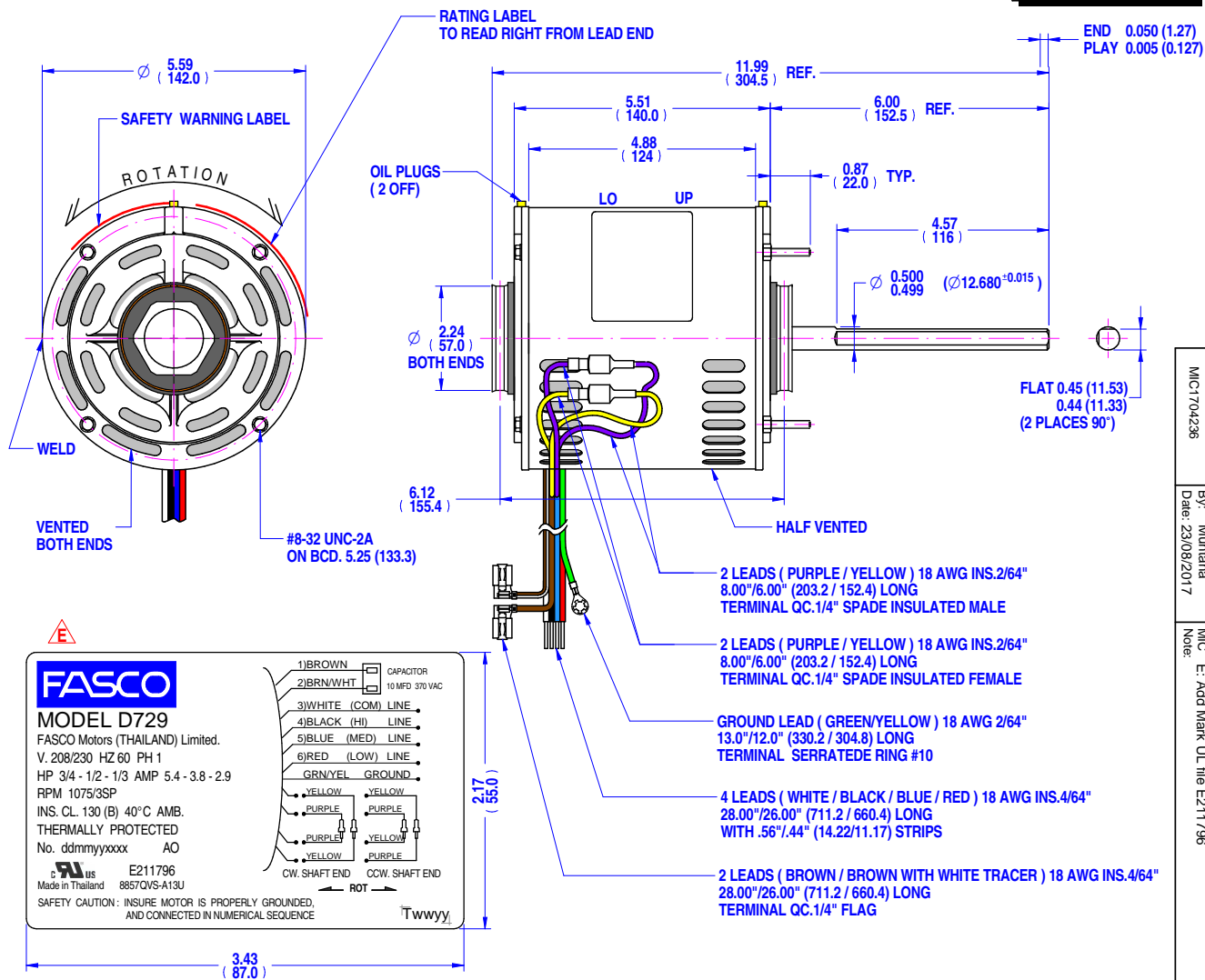

NOTE: DIMENSIONS SHOWN INCH (mm.)
STK - 62

SAFETY WARNING

THIS MOTOR MUST BE GROUNDED IN ACCORDANCE WITH LOCAL OR NATIONAL ELECTRICAL CODES TO PREVENT POSSIBLE INJURY DUE TO ELECTRICAL SHOCK

P071946

SPECIAL REQUIREMENTS:

- CAPACITOR SUPPLIED BY CUSTOMER.
- DO NOT PACK MOTOR IN PLASTIC BAG.
- PUSH AND PULL SHAFT TO CENTRALIZE WASHER SLINGER.
- STAMP FDC PART NUMBER FDC-D729 ON THE BULK PACK.
- ADD SAFETY BOOK P/N 398-063-02 IN ALL INDIVIDUAL CARTON.

UNLESS OTHERWISE SPECIFIED : DIMENSIONS ARE IN MM. TOLERANCES		MOTOR WEIGHT	
DECIMALS	ANGULAR	7.9 kg.	
.X ± 1.0	± 30'	DRAWN	muntana 24/10/2013
.XX ± 0.1		CHECKED	Pipat 24/08/2017
THIS DRAWING REMAINS THE PROPERTY OF FASCO MOTORS AND MAY NOT BE USED, COPIED OR ISSUED WITHOUT WRITTEN PERMISSION FROM FASCO MOTORS		RELEASED	Sutthipant 24/08/2017
		SCALE	N.T.S.

<p>29/7-8 MOO 3, BANGKRUAY - SAINOI Rd., BANGKRANG, MIJANG NONTHABURI DISTRICT, NONTHABURI 11000 THAILAND</p>	FRAME	MOTOR	
	STATUS	R	S031:8857V-707-MCX:FDC
	SHEET	A3	DWG. NO. 8857QVS-A13U
	REVISION	E	