

PRODUCT INFORMATION PACKET

FASCO®

Model No: D701

Catalog No: D701

1/2-1/3-1/4-1/5 HP Fan & Blower Motor, 1075 RPM, 4 Speed, 115 Volts, 48 Frame, OAO
Direct Drive Motors



Regal and Fasco are trademarks of Regal Beloit Corporation or one of its affiliated companies.
©2020 Regal Beloit Corporation, All Rights Reserved. MC017097E

REGAL



Nameplate Specifications

Output HP	1/2-1/3-1/4-1/5 Hp	Output KW	0.37 kW
Frequency	60 Hz	Voltage	115 V
Current	7.7-5.5-4.2-3.3 A	Speed	1075 rpm
Service Factor	1	Phase	1
Duty	Continuous	Insulation Class	B
Frame	48	Enclosure	Open Air Over
Thermal Protection	Automatic	Ambient Temperature	40 °C
UL	Recognized	CSA	Y
CE	N		

Technical Specifications

Electrical Type	Permanent Split Capacitor	Starting Method	Across The Line
Poles	6	Rotation	Reversible
Mounting	Extended Studs	Drive End Bearing	Sleeve
Opp Drive End Bearing	Sleeve	Frame Material	Rolled Steel
Shaft Type	Double Flat	Frame Length	5.39 in
Shaft Diameter	0.500 in	Shaft Extension	5.43 in
Outline Drawing	8557PVA-A11U		

This is an uncontrolled document once printed or downloaded and is subject to change without notice. Date Created:06/11/2020

MOTOR SPECIFICATION

8557PVA-A11U

Q.R. No.	Y001170-2	CUSTOMER NO.	D701					
CUSTOMER	FASCO USA							
MOTOR RATING	VOLTS	115	Hz	60	Ph	1	Duty	S1 AOM
	RPM.	1075/4SP			7.7		AMPS	
NOM. OUTPUT	475 WATTS (1/2 HP)							
ROTATION	REVERSIBLE							
CAPACITOR	START	-----	μF/V	RUN	10/---		μF/V	
ENCLOSURE	VENTED							
MOTOR TYPE	PSC	INSULATION CLASS	130 (B)					
THERMAL PROTECTION	AUTO RESET OVERLOAD							
APPLICATION	FAN AXIAL - SHAFT HORIZONTAL							
BEARING D.E.	SLEEVE	LUBRICATION	PERMAWICK OPERA.TEMP					
BEARING N.D.E.	SLEEVE		-15°-90°C					
SUPPLY LEAD	AS SHOWN							
EARTH PROVISION	SUPPLIED							
BASIC BUILD SPECIFICATION	305-742-05	PAINT/ COLOUR	PC GREY PLAIN E/SHIELDS					
PERFORMANCE SPECIFICATION	SP85260-01							
CONNECTION DIAGRAM	AS SHOWN	RATING LABEL	AS SHOWN					

FINAL INSPECTED MOTORS MUST COMPLY WITH ELECTRIC MOTOR VIBRATION SPECIFICATION (ES049)

THIRD ANGLE PROJECTION

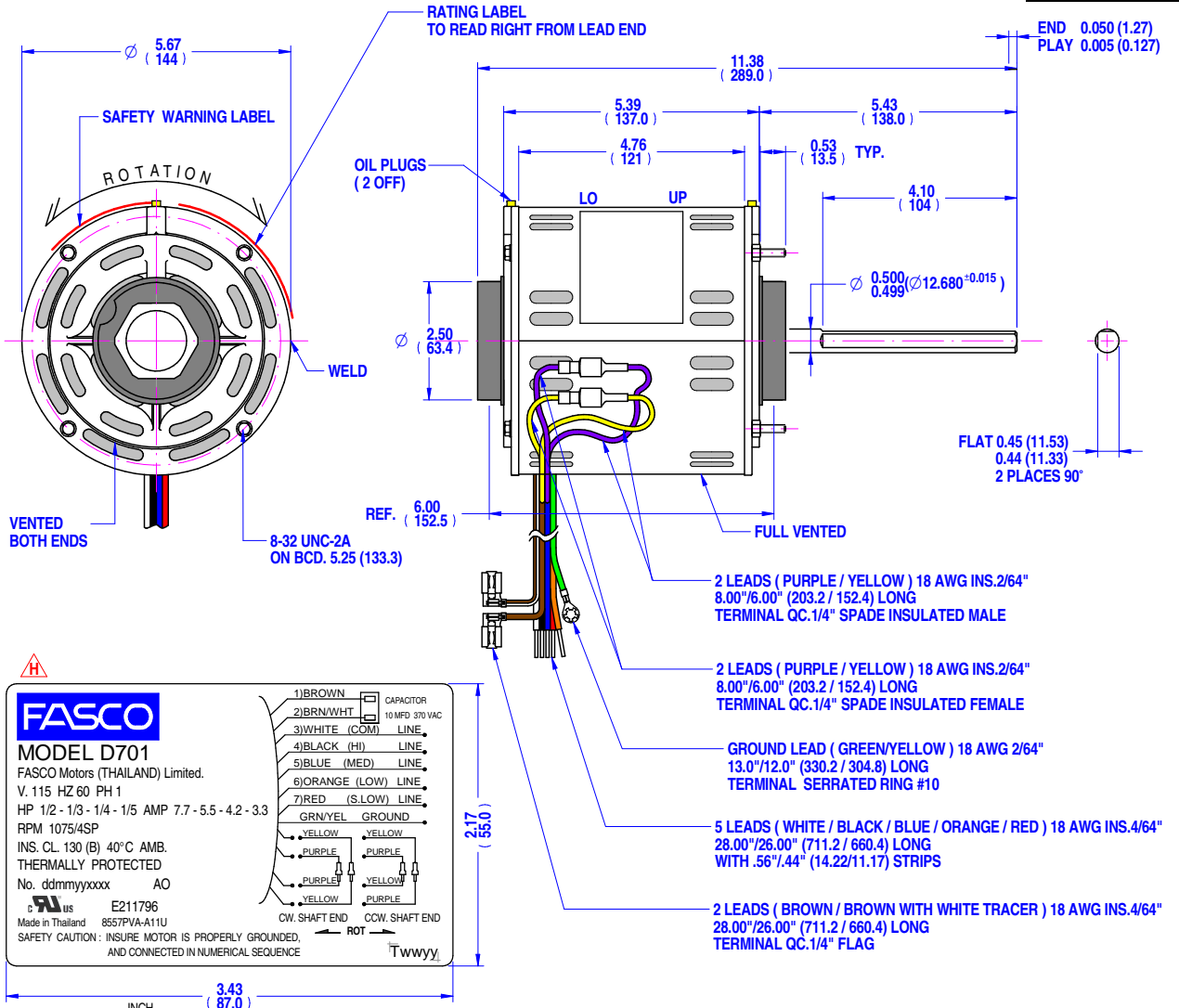

FASCO
MODEL D701
 FASCO Motors (THAILAND) Limited.
 V. 115 HZ 60 PH 1
 HP 1/2 - 1/3 - 1/4 - 1/5 AMP 7.7 - 5.5 - 4.2 - 3.3
 RPM 1075/4SP
 INS. CL. 130 (B) 40° C AMB.
 THERMALLY PROTECTED
 No. ddmmvxxxx AO
 E211796
 Made in Thailand 8557PVA-A11U
 SAFETY CAUTION: INSURE MOTOR IS PROPERLY GROUNDED, AND CONNECTED IN NUMERICAL SEQUENCE

WIRING DIAGRAM:

- 1) BROWN CAPACITOR
- 2) BRN/WHT 10 MFD 370 VAC
- 3) WHITE (COM) LINE
- 4) BLACK (HI) LINE
- 5) BLUE (MED) LINE
- 6) ORANGE (LOW) LINE
- 7) RED (SLOW) LINE
- GRN/YEL GROUND
- YELLOW GROUND
- PURPLE GROUND
- PURPLE GROUND
- PURPLE GROUND
- PURPLE GROUND
- PURPLE GROUND
- PURPLE GROUND

CW. SHAFT END CCW. SHAFT END
 ROT

NOTE: DIMENSIONS SHOWN INCH (mm.)
 STK - 50

SAFETY WARNING
 THIS MOTOR MUST BE GROUNDED IN ACCORDANCE WITH LOCAL OR NATIONAL ELECTRICAL CODES TO PREVENT POSSIBLE INJURY DUE TO ELECTRICAL SHOCK
 P071946

SPECIAL REQUIREMENTS:

- CAPACITOR SUPPLIED BY CUSTOMER.
- DO NOT PACK MOTOR IN PLASTIC BAG.
- PUSH AND PULL SHAFT TO CENTRALIZE WASHER SLINGER.
- STAMP FDC PART NUMBER FDC-D701 ON THE BULK PACK.
- ADD SAFETY BOOK P/N 398-063-02 IN ALL INDIVIDUAL CARTON.

UNLESS OTHERWISE SPECIFIED: DIMENSIONS ARE IN MM. TOLERANCES	MOTOR WEIGHT	7.6 kg.
DECIMALS .X ± 1.0 .XX ± 0.1	ANGULAR ± 30'	
DRAWN	Nithad	20/09/2003
CHECKED	Pipat	18/08/2017
RELEASED	Sutthipant	18/08/2017
SCALE	N.T.S.	

 29/7-8 MOO 3, BANGKRUAY - SAINOI Rd., BANGKRANG, MIJANG NONTHABURI DISTRICT, NONTHABURI 11000 THAILAND	FRAME	MOTOR
	STATUS	R
	SHEET	S260:8557V-475-MCX:FDC
	A3	DWG. NO. 8557PVA-A11U
	REVISION	H

By: Muntana
 Date: 18/08/2017
 MIC - H - CANCEL UL TYPE AT NAME PLATE
 Note: