

# PRODUCT INFORMATION PACKET

FASCO®

Model No: D354

Catalog No: D354

1/6-1/10-1/20 HP Fan Coil / Room Air Conditioner Motor, 1050 RPM, 3 Speed, 115 Volts, 42 Frame, OAO  
Fan Coil / Room Air Conditioner Motors



Regal and Fasco are trademarks of Regal Beloit Corporation or one of its affiliated companies.  
©2020 Regal Beloit Corporation, All Rights Reserved. MC017097E

REGAL



**Nameplate Specifications**

Output HP	1/6-1/10-1/20 Hp	Output KW	0.13 kW
Frequency	60 Hz	Voltage	115 V
Current	2.8/1.8/1.0 A	Speed	1050 rpm
Service Factor	1	Phase	1
Duty	Continuous	Insulation Class	B
Frame	42	Enclosure	Open Air Over
Thermal Protection	Automatic	Ambient Temperature	40 °C
UL	Recognized	CSA	Y
CE	N		

**Technical Specifications**

Electrical Type	Permanent Split Capacitor	Starting Method	Across The Line
Poles	6	Rotation	Counterclockwise Lead End
Mounting	Resilient Rings	Drive End Bearing	Sleeve
Opp Drive End Bearing	Sleeve	Frame Material	Na
Shaft Type	Flat	Overall Length	20.82 in
Shaft Diameter	0.500 in	Shaft Extension	8.5 in
Connection Drawing	SEE OUTLINE	Outline Drawing	7186002308_S001

This is an uncontrolled document once printed or downloaded and is subject to change without notice. Date Created:22/09/2020

- NOTES:
1. THRU AIR SPACING BETWEEN WIRE AND METAL .094 MIN.
  2. THE BOLT TOLERANCE 7 - 12 IN. LBS.
  3. FOR WASHER SET-UP SEE CHART C600 0279, DETAIL "A".
  4. SALES TO SPECIFY ON P.O. WHICH PACK TO USE.

ECO	REV.	DATE	SPEC/CHECK
631865	5	10-3-03	DJK/RWS
638385	6	7-11-08	MKR/MKR
639157	7	3-5-09	MKR/MKR
641681	8	10-19-10	MKR/MKR

- A. SEE PACKAGING MANUAL PAGE 2 FOR PACKAGING PROCEDURES.
- 1 MOTOR/CARTON;  
16 MOTOR/LAYER;  
6 LAYERS/PALLET;  
96 MOTOR/PALLET.
- B. SEE DRAWING 8786 6079 SH. 1 FOR PALLET LAYOUT.  
C. CENTER LABEL, 6120 6112, ON END OF CARTON.  
D. PLACE PAMPHLET, 6122 4579, IN CARTON WITH MOTOR.

PRODUCTION TEST AT 115 VOLTS 60 HZ	MOTOR SPEED	PERFORMANCE TEST 115 VOLTS 60 HZ				LOADED 1 PH 1/6 HP CAP. 4 MFD 370 VAC				BREAK OZ/IN
		IDLE		1 PH 1/6 HP		LOCKED		WATT		
AMP	WATT	RPM	AMP	WATT	AMP	WATT	OZ/IN		AMP	WATT
1.52 — 1.24	106.7 — 87.3	1191	1.38	97	188.0	282	60.0	4.61	476	210.0
.84 — .68	68.2 — 55.8	1185	.76	62	108.0	170	36.0	2.95	288	117.0
.41 — .33	36.3 — 29.7	1184	.37	33	61.0	87	24.0	1.96	151	73.0
HI-POT TEST 2000 VOLTS										
MAX LEAKAGE CURRENT 5 mA										

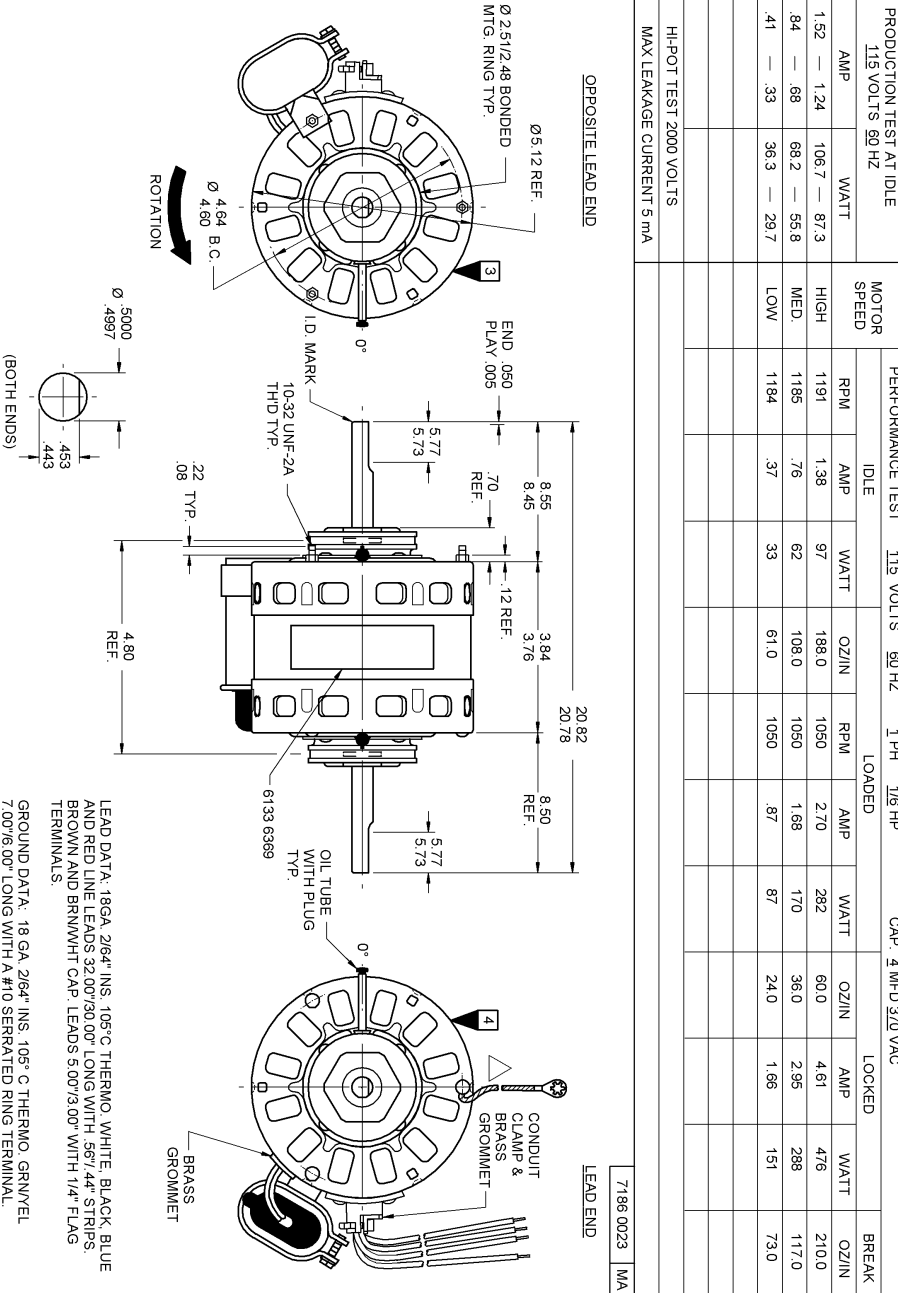

LEAD DATA: 18GA 2/64" INS. 105°C THERMO. WHITE, BLACK, BLUE AND RED LINE LEADS 32.00" 30.00" LONG WITH .581/.44" STRIPS BROWN AND BRN/WHIT CAP. LEADS 5.00" 73.00" WITH 1/4" FLAG TERMINALS.

GROUND DATA: 18 GA 2/64" INS. 105° C THERMO. GRN/YEL 7.00"/6.00" LONG WITH A #10 SERRATED RING TERMINAL.

7186 0023 = MADE IN U.S.A. / 7186 0023R = ASSEMBLED IN MEXICO.

**FASCO** INDUSTRIES, INC. MOTOR DIVISION

MODEL **D354**

HP 1/6-1/10-1/20 / HP 1/8-1/4 / HP 1/4-1/2

AMP 2.8-1.8-1.0 / AMP 2.8-1.8-1.0 / AMP 2.8-1.8-1.0

INS CL. B / INS CL. B / INS CL. B

40°C TYPE 018661 NO. 7186-0023 / 40°C TYPE 018661 NO. 7186-0023 / 40°C TYPE 018661 NO. 7186-0023

SAFETY WARNING: THIS MOTOR MUST BE GROUNDED IN ACCORDANCE WITH THE NATIONAL ELECTRICAL CODE TO PREVENT POSSIBLE INJURY DUE TO ELECTRICAL SHOCK.

DATE/BAE CODE AREA PER 8882 6003

6133 6369 R REV. 3

LOCATE  $\odot$  OF NAMEPLATE ON  $\odot$  OF STATOR TO READ RIGHT FROM LEAD END OF MOTOR CENTER AT 0°.

SIZE 3.50 X 1.00

SPECIAL INSTRUCTIONS: FLATS TO BE PARALLEL WITHIN ± 20°.

SHAFT IS BONDZERIZED. ASSEMBLE CAPACITOR SO THAT IT WILL NOT INTERFERE WITH CONDUIT CLAMP SCREWS. GROUND STRAP TERMINAL IS NOT TO EXTEND BEYOND MOTOR PERIPHERY. PAMPHLET PACKED WITH MOTOR.

MOTORS PACKED MAX. PER SKID: PALLET PACK 96 CARTON PACK, TRAY PACK.

CUSTOMER: FASCO DISTRIBUTING CO.

PART NUMBER: D354

APPLICATION: DIST. SALES

FINISH COLOR: GRAY

MOTOR WEIGHT: 9.95 LBS.

ENVIRONMENT: DRY

INSULATION CLASS: B

MOTOR TYPE	MOTOR NUMBER	REV.
P.S.C.	7186 0023	8