

PRODUCT INFORMATION PACKET

FASCO®

Model No: D277

Catalog No: D277

1/10-1/12-1/20 HP Fan Coil / Room Air Conditioner Motor, 1050 RPM, 3 Speed, 277 Volts, 42 Frame, OAO
Fan Coil / Room Air Conditioner Motors



Regal and Fasco are trademarks of Regal Beloit Corporation or one of its affiliated companies.
©2020 Regal Beloit Corporation, All Rights Reserved. MC017097E

REGAL



Nameplate Specifications

Output HP	1/10-1/12-1/20 Hp	Output KW	0.07 kW
Frequency	60 Hz	Voltage	277 V
Current	0.7/0.5/0.4 A	Speed	1050 rpm
Service Factor	1	Phase	1
Duty	Continuous	Insulation Class	B
Frame	42	Enclosure	Open Air Over
Thermal Protection	Automatic	Ambient Temperature	40 °C
UL	Recognized	CSA	Y
CE	N		

Technical Specifications

Electrical Type	Permanent Split Capacitor	Starting Method	Across The Line
Poles	6	Rotation	Clockwise Lead End
Mounting	Extended Studs	Drive End Bearing	Ball
Opp Drive End Bearing	Ball	Frame Material	Na
Shaft Type	Flat	Overall Length	20.82 in
Shaft Diameter	0.500 in	Shaft Extension	8.50 in
Connection Drawing	SEE OUTLINE	Outline Drawing	7186002710_S001

This is an uncontrolled document once printed or downloaded and is subject to change without notice. Date Created:06/11/2020

- NOTES:
1. THRU AIR SPACING BETWEEN WIRE AND METAL .094 MIN.
 2. THE BOLT TOLERANCE 7 - 12 IN. LBS.
 3. FOR WASHER SET-UP SEE CHART C600 0279, DETAIL "A".
 4. SALES TO SPECIFY ON P.O. WHICH PACK TO USE.

ECO	REV.	DATE	SPEC/CHECK
642196	10	7-15-11	MKR/MKR
638386	7	7-11-08	MKR/MKR
639202	8	03-12-09	GAE/GAE
641602	9	9-24-10	LDC/LDC

A. SEE PACKAGING MANUAL PAGE 2 FOR PACKAGING PROCEDURES.

1 MOTOR/CARTON;
16 MOTORS/LAYER;
6 LAYERS/PALLET;
96 MOTORS/PALLET.

71xx xxxx,R

B. SEE DRAWING 8786 6079 SH. 1 FOR PALLET LAYOUT.
C. CENTER LABEL, 6119 6026 ON END OF CARTON.
D. PLACE PAMPHLET, 6122 4579, IN CARTON WITH MOTOR.

71xx xxxxC

71xx xxxxZ

PRODUCTION TEST AT IDLE		PERFORMANCE TEST										BREAK		
227 VOLTS 60 HZ		227 VOLTS 60 HZ					1 PH 1/10 HP					CAP. 4 MFD 320 VAC		
AMP	WATT	IDLE		LOADED		LOADED		LOADED		AMP	WATT	OZ/IN		
		RPM	AMP	WATT	OZ/IN	RPM	AMP	WATT	OZ/IN	AMP	WATT	OZ/IN		
.39	— .32	86.9	— 71.1	HIGH	1192	.35	79	128.0	1050	.65	179	.98	266	137.0
.26	— .22	62.7	— 51.3	MED.	1191	.24	57	85.0	1050	.44	121	.69	177	93.0
.20	— .16	47.3	— 38.7	LOW	1190	.18	43	60.0	1050	.31	86	.49	122	65.0

HI-POT TEST 2000 VOLTS		MAX LEAKAGE CURRENT 5 mA	

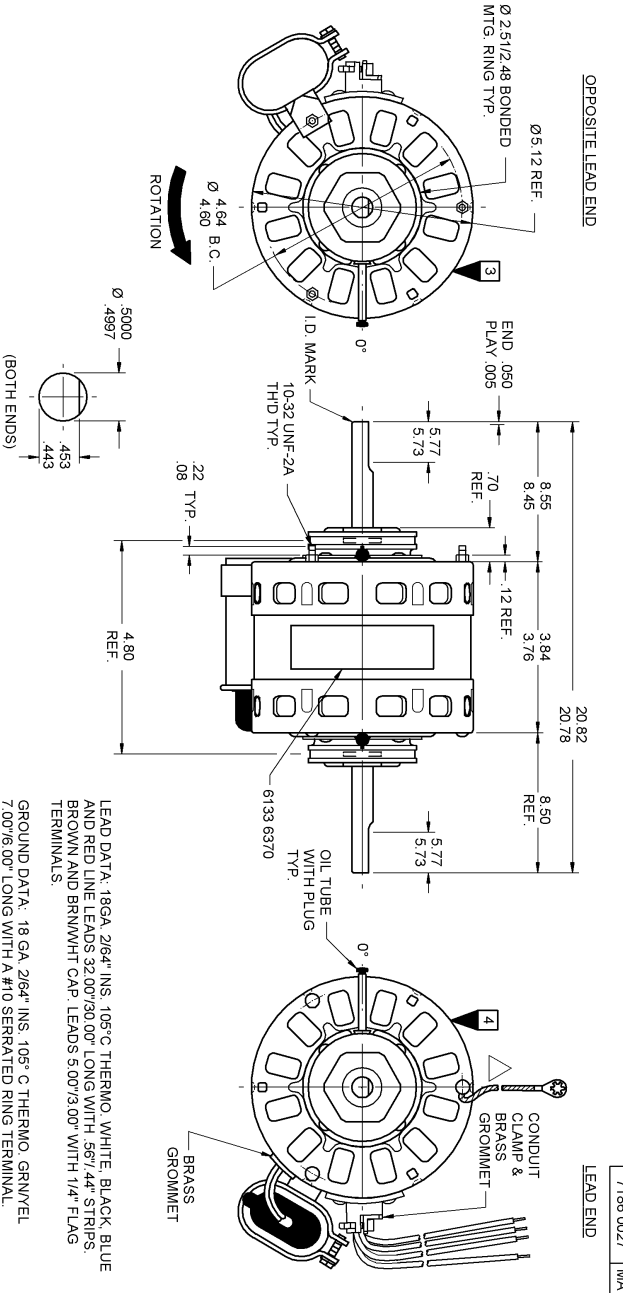

FASCO INDUSTRIES, INC.
MOTOR DIVISION
ASSEMBLY IN MEXICO

MODEL D277

HP 1110-1112-1120
V 277
HZ 60
PH 1
RPT →
AMP .7-.5-.4
TNS CL B 40° C
RPM 1050 (3 SPD)
NO. 7186-0027
RPM 1050 (3 SPD)

SAFETY WARNING
THIS MOTOR MUST BE GROUNDED IN ACCORDANCE WITH THE NATIONAL ELECTRICAL CODE (NEC) TO PREVENT POSSIBLE INJURY DUE TO ELECTRICAL SHOCK.

DATE/ISSN CODE AREA PER 8882 6003

6133 6370 R REV. 4

THERMALLY PROTECTED

CONNECTION DIAGRAM

BRN → BROWN
BLK-WHT → CAPACITOR
RED → RED
LINE → LINE

DATE/ISSN CODE AREA PER 8882 6003

LOCATE **⊗** OF NAMEPLATE ON **⊗** OF STATOR TO READ RIGHT FROM LEAD END OF MOTOR CENTER AT **⊗**.

SIZE 3.50 X 1.00

SPECIAL INSTRUCTIONS: FLATS TO BE PARALLEL WITHIN ± 20°

SHAFT IS BONDERIZED. ASSEMBLE CAPACITOR SO THAT IT WILL NOT INTERFERE WITH CONDUIT CLAMP SCREWS. GROUND STRAP TERMINAL IS NOT TO EXTEND BEYOND MOTOR PERIPHERY. PAMPHLET PACKED WITH MOTOR.

MOTORS PACKED MAX. PER SKID: PAMPHLET PACKED WITH MOTOR.

CUSTOMER: FASCO DISTRIBUTING CO.

PART NUMBER: D277

APPLICATION: DIST. SALES

FINISH COLOR: GRAY

MOTOR WEIGHT: 9.50 LBS.

ENVIRONMENT: DRY

INSULATION CLASS: B

MOTOR TYPE	MOTOR NUMBER	REV.
P.S.C.	7186 0027	10