

# PRODUCT INFORMATION PACKET

FASCO®

Model No: D227  
Catalog No: D227  
1/20 HP Fan & Blower Motor, 1550 RPM, 115 Volts, 3.3" Diameter, TEFC  
Self Cooled Motors



Regal and Fasco are trademarks of Regal Beloit Corporation or one of its affiliated companies.  
©2019 Regal Beloit Corporation, All Rights Reserved. MC017097E

REGAL



**Nameplate Specifications**

Output HP	1/20 Hp	Output KW	0.04 kW
Frequency	60 Hz	Voltage	115 V
Current	1.80 A	Speed	1500 rpm
Service Factor	1	Phase	1
Duty	Air Over	Insulation Class	B
Frame	3.3	Enclosure	Totally Enclosed
Thermal Protection	Thermally Protected	Ambient Temperature	40 °C
UL	Recognized	CSA	Y
CE	N		

**Technical Specifications**

Electrical Type	Shaded Pole	Starting Method	Across The Line
Poles	4	Rotation	Counterclockwise Shaft End
Mounting	Extended Studs	Drive End Bearing	Ball
Opp Drive End Bearing	Ball	Frame Material	Steel
Shaft Type	Flat	Overall Length	6.57 in
Frame Length	2.82 in	Shaft Diameter	0.312 in
Shaft Extension	2.30 in		

This is an uncontrolled document once printed or downloaded and is subject to change without notice. Date Created:29/10/2019

14	REVISED TO CLINCH STUDS, UPDATED TYPICAL PERFORMANCE	SD 7-1-04	15	REVISED TO CURRENT STANDARDS	02/08/2008	16	REMOVED BARCODE FROM AND ADDED CSA NUMBER TO NAMEPLATE	BP 08/03/2010	STANDARD TOLERANCES: ANGULAR +/- 1 DEGREE 2 PLACE DECIMAL +/- .01 3 PLACE DECIMAL +/- .005		
----	--	-----------	----	------------------------------	------------	----	--	---------------	---	--	--

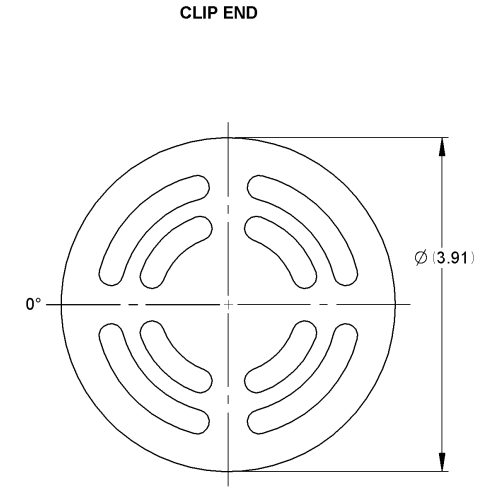
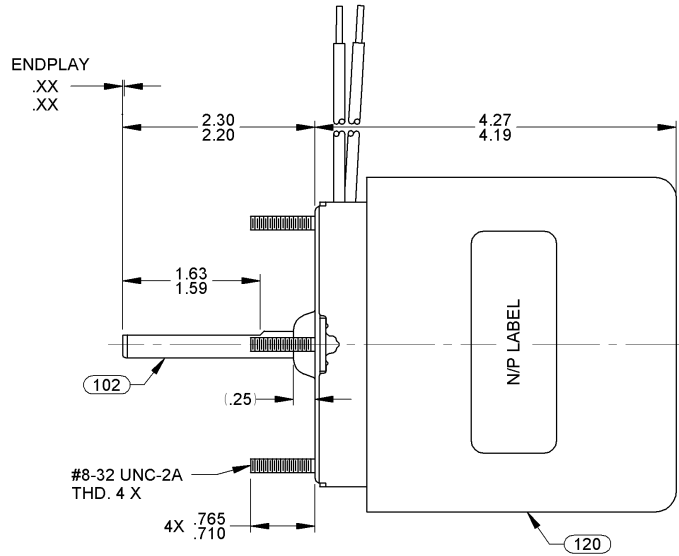
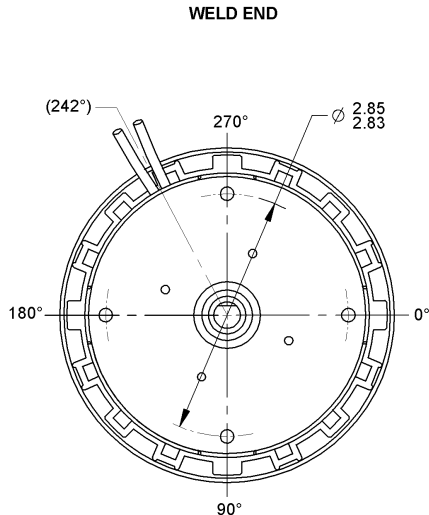

LEAD MATERIAL  
18 GA. 125° C 2/64 IN.  
X-LINK POLY., BLACK  
14.00/12.00 IN. LONG  
.68/.56 IN. STRIP

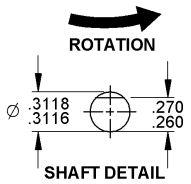

0046-4072

0046-4282

Fasco Industries, Inc.  
Motor Division

**FASCO**

Assembled In Mexico  
No. 71634245 TYPE U63B1  
115 V 60 Hz  
1.8 A 1550 RPM  
Model D227  
Max Amb: 40°C  
LR6319

T.P. TEAO  
Class B 1/20 HP  
Sealed Ball Brg

**SAFETY WARNING**  
 This Motor Must Be Grounded in Accordance With Local Or National Electrical Codes To Prevent Possible Injury Due To Electrical Shock

61299553

- NOTES:  
1. PACK 280 MOTORS MAX. PER PALLET.  
2. NO PACKING TAPE OVER CARTON LABEL.

FRONT SHAFT POSITION		* TYPICAL PERFORMANCE AT 115 VOLTS 60 Hz.											CUSTOMER: FASCO DIST.		FASCO MOTORS GROUP AC MOTOR/BLOWER DIVISION														
HORIZONTAL	MOTOR SPEED	IDLE			LOADED			LOCKED			BREAK	PART NUMBER: D227		CONFIDENTIAL; DO NOT DUPLICATE OR DISCLOSE TO THIRD PARTIES WITHOUT WRITTEN PERMISSION OF FASCO MOTORS GROUP, AC MOTOR/BLOWER DIVISION.															
		R.P.M.	AMP.	WATT	IN.OZ.	R.P.M.	AMP.	WATT	IN.OZ.	AMP.	WATT	IN.OZ.	APPLICATION: COUNTER SALES					MOTOR TYPE					DRAWING NUMBER						
	1750	1.36	68	30.0	1590	1.65	107	12.0	2.34	141	33.0	MOTOR WEIGHT: 4.57 LBS.		ENVIRONMENT: DRY					SHADED POLE					7163 4245					
CUSTOMER APPROVAL:													FINISH COLOR: BLACK		DRAWN BY: S. DALTON					DATE DRAWN: 3-7-2002					REV. 16				
SIGNED:																													
DATE:																													