

PRODUCT INFORMATION PACKET

FASCO®

Model No: D1155
Catalog No: D1155
1/100 HP OEM Replacement Motor, 1085 RPM, 115 Volts, 3.3" Diameter, TEAO
HVAC/R OEM Replacement Motors



Regal and Fasco are trademarks of Regal Beloit Corporation or one of its affiliated companies.
©2019 Regal Beloit Corporation, All Rights Reserved. MC017097E

REGAL



Nameplate Specifications

Output HP	1/100 Hp	Output KW	0.01 kW
Frequency	60 Hz	Voltage	115 V
Current	0.50 A	Speed	1085 rpm
Service Factor	1	Phase	1
Duty	Air Over	Insulation Class	B
Frame	3.3	Enclosure	Totally Enclosed Air Over
Thermal Protection	Thermally Protected	Ambient Temperature	40 °C
UL	Recognized	CSA	Y
CE	N		

Technical Specifications

Electrical Type	Shaded Pole	Starting Method	Across The Line
Poles	6	Rotation	Counterclockwise Shaft End
Mounting	Extended Studs	Drive End Bearing	Sleeve
Opp Drive End Bearing	Sleeve	Frame Material	Steel
Shaft Type	Flat	Overall Length	3.63 in
Frame Length	2.07 in	Shaft Diameter	0.250 in
Shaft Extension	1 in		

This is an uncontrolled document once printed or downloaded and is subject to change without notice. Date Created:29/10/2019

09	FLOW MOTOR, REVISED TO CLINCH STUDS, UPDATE TO CURRENT STD'S	VL 08-19-04	10	REVISED NAMEPLATE LABEL	SD 2-22-08	11	REMOVED BARCODE FROM AND ADDED CSA NUMBER ON NAMEPLATE	BP 08/11/2010	STANDARD TOLERANCES: ANGULAR +/- 1 DEGREE 2 PLACE DECIMAL +/- .01 3 PLACE DECIMAL +/- .005
----	--	-------------	----	-------------------------	------------	----	--	---------------	---

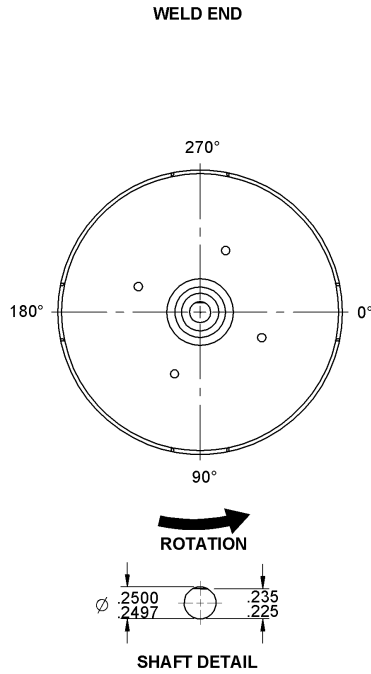

LEAD MATERIAL
18 GA. 2/64 INS. 125°C.
X-LINKED POLYETHYLENE
(2) BLACK, 12.00/10.00"
W/PIN TERMINALS
8903-9098 AMP #350687-1

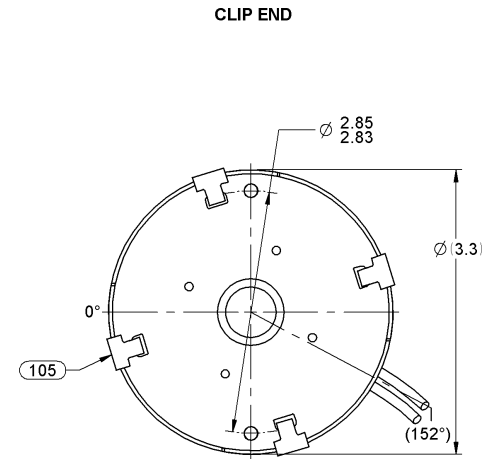
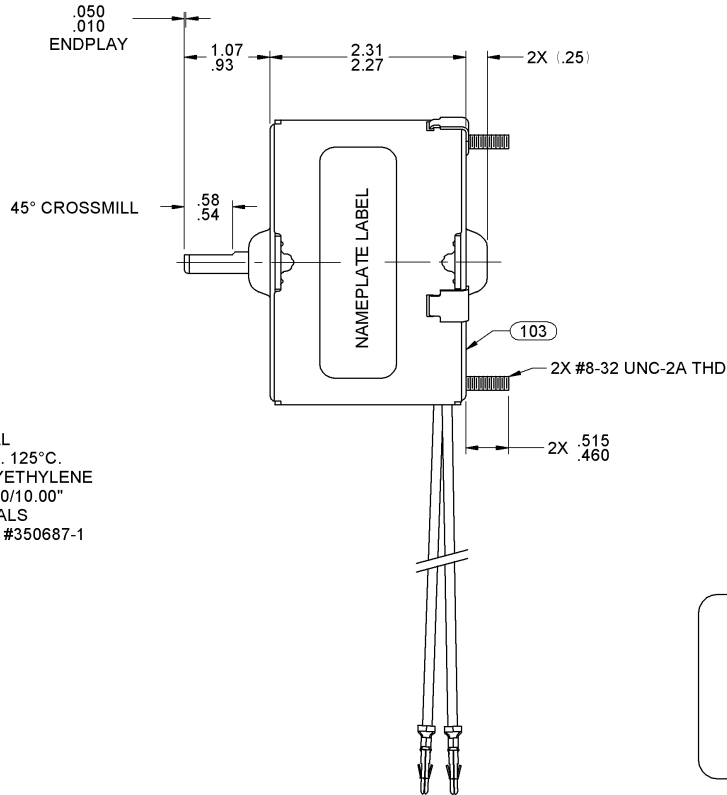

0046 4072 0046 4282

FASCO Fasco Industries, Inc.
Motor Division

Assembled in Mexico

No. 71639049 Type U63B1 T.P. TEAO LR6319
115 V 60 Hz Class B
0.5 A 1085 RPM 1/100 HP
Model D1155 Max Amb: 40° C

SAFETY WARNING

The Motor Must Be Grounded in Accordance With Local Or National Electrical Codes To Prevent Possible Injury Due To Electrical Shock

6129 9553

NOTES:

1. PACK 270 MOTORS MAXIMUM PER PALLET.
2. NO PACKING TAPE OVER CARTON LABEL.

FRONT SHAFT POSITION		* TYPICAL PERFORMANCE AT 115 VOLTS 60 Hz.										CUSTOMER: FASCO DISTRIBUTOR		FASCO FASCO MOTORS GROUP AC MOTOR/BLOWER DIVISION																	
HORIZONTAL	MOTOR SPEED	IDLE			LOADED			LOCKED			BREAK	PART NUMBER: D1155	CONFIDENTIAL; DO NOT DUPLICATE OR DISCLOSE TO THIRD PARTIES WITHOUT WRITTEN PERMISSION OF FASCO MOTORS GROUP, AC MOTOR/BLOWER DIVISION.																		
		R.P.M.	AMP.	WATT	IN.OZ.	R.P.M.	AMP.	WATT	IN.OZ.	AMP.	WATT	IN.OZ.	APPLICATION: VENTILATION	MOTOR TYPE					DRAWING NUMBER												
		1689	.47	32	9.2	1085	.60	50	5.1	.78	57	9.1	MOTOR WEIGHT: 2.06 POUNDS	SHADED POLE					7163 9049												
													ENVIRONMENT: DRY	REV. 11																	
													FINISH COLOR: BLACK	B	LA	FR	A	S	C	E	B	A	00	63	30	T	01	OU	5	1	0
													DRAWN BY: HELEN SHORT																		
													DATE DRAWN: MAY 09, 2002																		