

PRODUCT INFORMATION PACKET



Model No: FSE1038SF
Catalog No: FSE1038SF
1/3 HP Condenser Fan Motor, 825 RPM, 208-230 Volts, 48 Frame, TEAO
Condenser Fans Motors



Regal and Century are trademarks of Regal Beloit Corporation or one of its affiliated companies.
©2020 Regal Beloit Corporation, All Rights Reserved. MC017097E





Nameplate Specifications

Output HP	1/3 Hp	Output KW	0.25 kW
Frequency	60 Hz	Voltage	208-230 V
Current	2.1 A	Speed	825 rpm
Service Factor	1	Phase	1
Duty	Air Over	Insulation Class	F
Frame	48	Enclosure	Totally Enclosed
Thermal Protection	Automatic	Ambient Temperature	70 °C
UL	Recognized	CSA	Y
CE	N		

Technical Specifications

Electrical Type	Permanent Split Capacitor	Starting Method	Across The Line
Poles	8	Rotation	Reversible
Mounting	Extended Studs	Motor Orientation	Any
Drive End Bearing	Sleeve	Opp Drive End Bearing	Sleeve
Frame Material	Rolled Steel	Shaft Type	Double Flat
Overall Length	12.49 in	Frame Length	4.50 in
Shaft Diameter	0.500 in	Shaft Extension	6.5 in
Connection Drawing	614131-242	Outline Drawing	FSE1038SF-S01

This is an uncontrolled document once printed or downloaded and is subject to change without notice. Date Created:22/09/2020

GENERAL INFORMATION:

SHAFT RUNOUT: .001 [.03] T.I.R. PER INCH LENGTH OF EXTENSION

END PLAY: .010[.25] TO .063[1.60]

BEARINGS: SLEEVE

MOUNTING POSITION: ALL ANGLE

ELECTRICAL DATA:

OVERLOAD PROTECTOR: AUTOMATIC RESET (T.I. 7AM 304)

LINE LEADS: NO. 18 GA., .06 [1.5] THK. XLP 125°C INSUL.

REVERSING LEADS: NO. 18 GA., .03 [.8] THK. XLP 125°C INSUL.

GROUND LEAD: NO. 18 GA., .03 [.8] THK. (GREEN) INSUL.

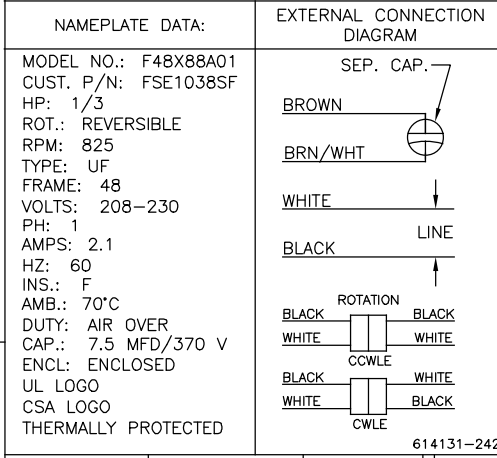
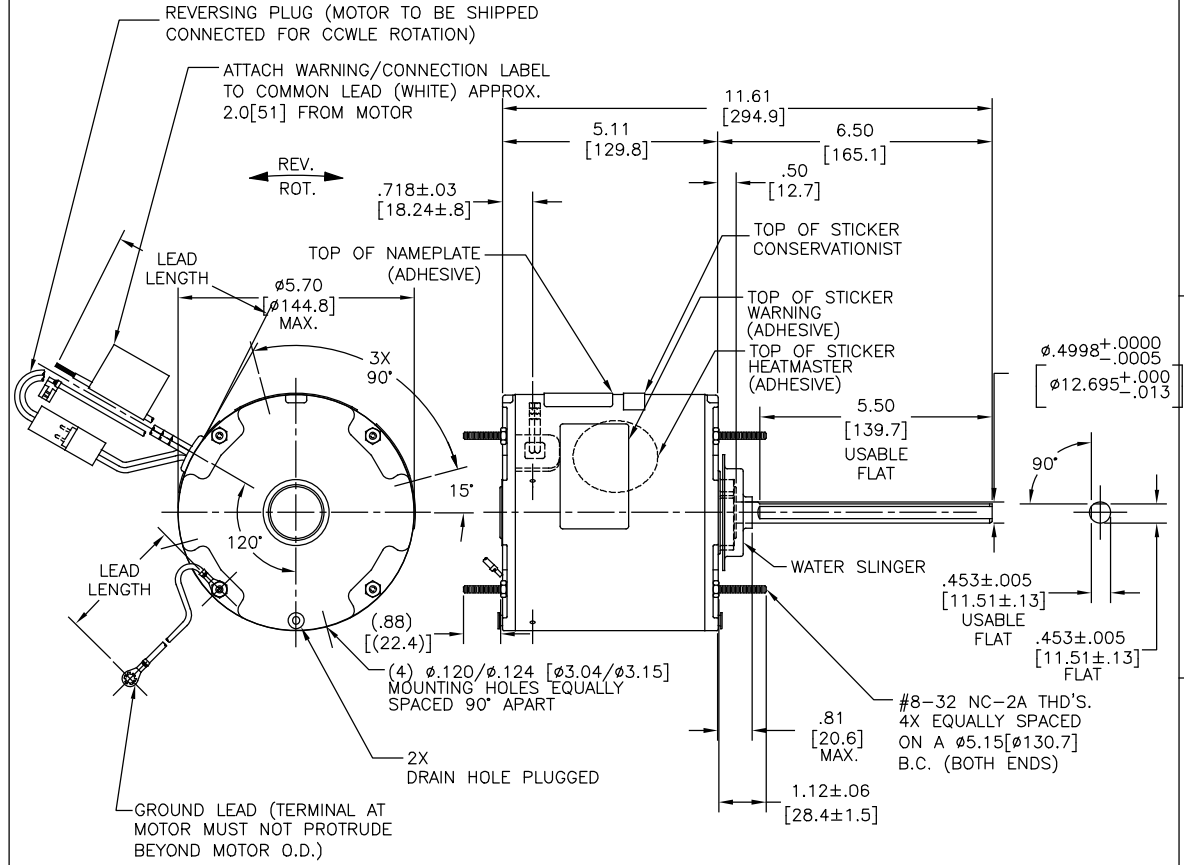

PERFORMANCE CURVE NO.	TORQUE @825 RPM (25°C)	APPROVED SAMPLE	UL COMPONENT	CSA
FILE #	CCN #	FILE #	CLASS #	
C32579	40.1 OZ.-FT.	0601196A	E46412	PRGY2 LR43341 4211-01

COLOR	LENGTH	TERMINAL OR STRIP LENGTH
GREEN (GROUND)	12.0/13.0 [305/330]	#10 EYELET
BLACK/WHITE	3.0/5.0 [76/127]	REVERSING PLUG
BROWN	48.0/51.0 [1219/1295]	.25 [6.4] FLAG
BROWN/WHITE	48.0/51.0 [1219/1295]	.25 [6.4] FLAG
WHITE	48.0/51.0 [1219/1295]	.50 [12.7] SKIN
BLACK	48.0/51.0 [1219/1295]	.50 [12.7] SKIN

REGAL-BELOIT CORPORATION (RBC) PROVIDES TECHNICAL ASSISTANCE TO OUR CUSTOMERS IN SEVERAL AREAS. SINCE RBC DOES NOT RECEIVE ALL DATA CONCERNING THE USE AND APPLICATION OF THE MOTOR, THE SUITABILITY OF THE MOTOR FOR THE APPLICATION MUST BE DETERMINED BY THE CUSTOMER.
DIMENSIONS WITHOUT TOLERANCES ARE FOR REFERENCE ONLY.
MAIN FRAME - OLE ENCLOSED
END FRAME - OLE ENCLOSED
MAIN FRAME - LE ENCLOSED
END FRAME - LE ENCLOSED

- NOTES:
- ATTACH INSTRUCTION SHEET 681572-003 ONTO SHAFT APPROX. 1.0[25] FROM WATER SLINGER (OR 69P9-3 ONLY USED IN MEXICO)
 - (4) SCREWS 615982-001 & (4) EXTRA HEX NUTS 7555A19H01 TO BE PUT IN A POLYBAG.

DRAWING REVISION	REVISION BY	DATE
D	GELINE ZHAO	05-23-2019
ECO	KEYUN GONG	05-23-2019

ENCLOSURE

THIRD ANGLE PROJECTION

DRAWN BY: A.NAJERA	DATE: 05-02-2011	REGAL Beloit America, Inc.
APPROVED BY: J.RUPERT	DATE: 05-02-2011	DESCRIPTION: MODEL-RFHP-48FR OUTLINE
PROCESS/FINISH	MATERIAL	
SIZE: C	DWG NO: FSE1038SF	SHEET: 1

4

3

2

1

REV	ECO	REV BY	DATE	APPD	DATE
D	0029048	D.RODRIGUEZ	10-18-2012	J.HESS	10-18-2012

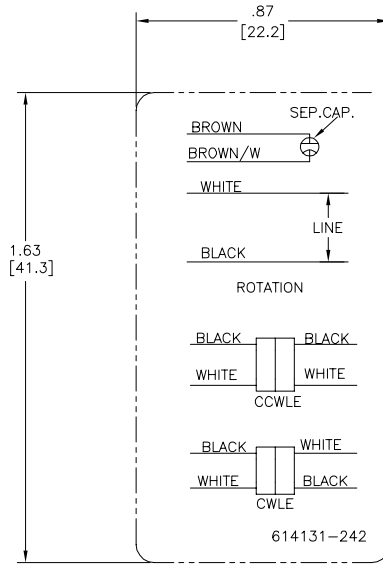

- NOTES:
 1. FOR USE WITH 614129 OR 2513020-001 NAMEPLATE BLANKS
 2. ----- INDICATES DIMENSION LIMITS

GEOMETRIC CHARACTERISTICS & SYMBOLS	
	FLATNESS
	STRAIGHTNESS
	ANGULARITY
	PERPENDICULARITY (SQUARENESS)
	PARALLELISM
	ROUNDNESS (CIRCULARITY)
	CYLINDRICITY
	PROFILE OF ANY SURFACE
	PROFILE OF ANY LINE
	RUNOUT
	TRUE POSITION
	CONCENTRICITY
	SYMMETRY

UNLESS OTHERWISE SPECIFIED DIM. TOLERANCES ARE AS FOLLOWS:	
INCH	± 0.1 ± 0.02 ± 0.005 ± 0.0005
mm	± 0.5 ± 0.13 ± 0.013
ANG. ± 50 DEG	
REMOVE BURRS & BREAK SHARP EDGES:	
INCH	$0.03-0.15$ mm $0.1-0.4$
CORNER FILLETS TO:	
INCH	0.020 mm 0.5
MACHINE SURFACES:	
INCH	125 mm 3.2
METRIC DIMS. SHOWN IN [BRACKETS]	

DR BY:	YL	04-15-2011
APPD:	HZ	04-15-2011
THIRD ANGLE PROJECTION		EDS DATE 11-11-2011 FORMAT REV H
CONFIDENTIAL: THIS DRAWING AND ITS INFORMATION ARE THE EXCLUSIVE AND CONFIDENTIAL PROPERTY OF REGAL-BELOIT CORPORATION AND ARE NOT TO BE DISCLOSED, DUPLICATED, DISTRIBUTED OR OTHERWISE USED WITHOUT THE WRITTEN CONSENT OF REGAL-BELOIT CORPORATION. -ALL RIGHTS RESERVED.		

REGAL-BELOIT CORPORATION	
DESCRIPTION CONN DIAGRAM-NAMEPLATE	
SIZE C	DWG NO 614131-242
SCALE NONE	SHEET 1

4

3

2

1

4

3

2

1

REVISION:	ECO	REVISADO POR:	FECHA:	APROBADO POR:	FECHA:
D	0029048	D.RODRIGUEZ	10-18-2012	J.HESS	10-18-2012



NOTAS:
 1. PARA USO CON PLACA DE DATOS EN BLANCO REGAL-BELOIT BANKS
 2. INDICATES DIMENSION LIMITS
 INDICA LIMITES DE DIMENSION

CARACTERISTICAS DE GEOMETRIA Y SIMBOLOS ▽ PLANICIDAD — RECTITUD ∠ ANGULARIDAD ⊥ PERPENDICULARIDAD (A ESQUADRA) // PARALELISMO ○ REDONDEZ (CIRCULARIDAD) ⌀ CILINDRICIDAD ~ PERFIL DE CUALQUIER SUPERFICIE ∩ PERFIL DE CUALQUIER LINEA † VARIACION ⊕ POSICION REAL ⊙ CONCENRICIDAD ≡ SIMETRIA	A MENOS QUE SE ESPECIFIQUE DE OTRA MANERA, LAS TOLERANCIAS DE LAS DIMS. SON LAS SIGUIENTES: PULG ±.1 ±.02 ±.005 ±.0005 mm ±0.5 ±0.13 ±0.013 ANG. ±50 GRADOS ELIMINAR REBASAS Y ORILLAS FILOSAS DEL BORDE. PULG .003-.015 mm 0.1-0.4 FILETEAR ESQUINA: PULG .020 mm 0.5 MAQUINAR SUPERFICIES PULG 125 mm 3.2 DIMS METRICAS MOSTRADAS [PARENTESIS]	DIBUJADO POR: YL	04-15-2011	REGAL-BELOIT CORPORATION
		APROBADO POR: HZ	04-15-2011	
		TERCER ANGULO DE PROYECCION	FECHA EDS: 11-11-2011 REV. FORMATO: H	TAMAÑO: C
		CONFIDENCIAL: ESTE DIBUJO Y SU INFORMACION SON PROPIEDAD DE USO EXCLUSIVO Y CONFIDENCIAL DE REGAL-BELOIT CORPORATION. Y NO DEBERAN SER REVELADOS, DUPLICADOS, DISTRIBUIDOS O USARSE DE OTRA MANERA SIN EL CONSENTIMIENTO ESCRITO DE REGAL-BELOIT CORPORATION. -TODOS LOS DERECHOS RESERVADOS.		NUMERO DE DIBUJO: 614131-242
		ESCALA: NONE		HOJA: 1

4

3

2

1