

PRODUCT INFORMATION PACKET

FASCO®

Model No: D132
Catalog No: D132
1/20 HP Fan & Blower Motor, 1500 RPM, 115 Volts, 3.3" Diameter, Semi Enclosed
Self Cooled Motors



Regal and Fasco are trademarks of Regal Beloit Corporation or one of its affiliated companies.
©2019 Regal Beloit Corporation, All Rights Reserved. MC017097E

REGAL



Nameplate Specifications

Output HP	1/20 Hp	Output KW	0.04 kW
Frequency	60 Hz	Voltage	115 V
Current	1.80 A	Speed	1500 rpm
Service Factor	1	Phase	1
Duty	Air Over	Insulation Class	B
Frame	3.3	Enclosure	Open Air Over
Thermal Protection	Thermally Protected	Ambient Temperature	40 °C
UL	Recognized	CSA	Y
CE	N		

Technical Specifications

Electrical Type	Shaded Pole	Starting Method	Across The Line
Poles	4	Rotation	Clockwise Shaft End
Mounting	Extended Studs	Drive End Bearing	Sleeve
Opp Drive End Bearing	Sleeve	Frame Material	Steel
Shaft Type	Flat	Overall Length	5.16 in
Frame Length	2.55 in	Shaft Diameter	0.313 in
Shaft Extension	2.30 in		

This is an uncontrolled document once printed or downloaded and is subject to change without notice. Date Created:29/10/2019

52	PICTORIALLY REMOVED BARCODE FROM LABEL	SD 10-23-09	53	CHANGED IDLE AMPS FROM 1.30 TO 1.50	PLA 11/19/09	54	CORRECTED PC NUMBER ON ROTOR/SHAFT DRAWING	C440448 SD 10-13-10	STANDARD TOLERANCES: ANGULAR +/- 1 DEGREE 2 PLACE DECIMAL +/- .01 3 PLACE DECIMAL +/- .005
----	--	-------------	----	-------------------------------------	--------------	----	--	------------------------	---

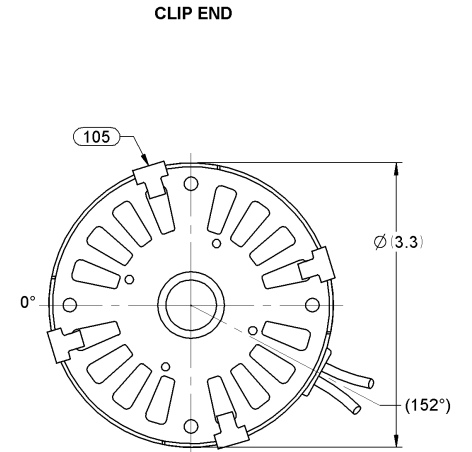
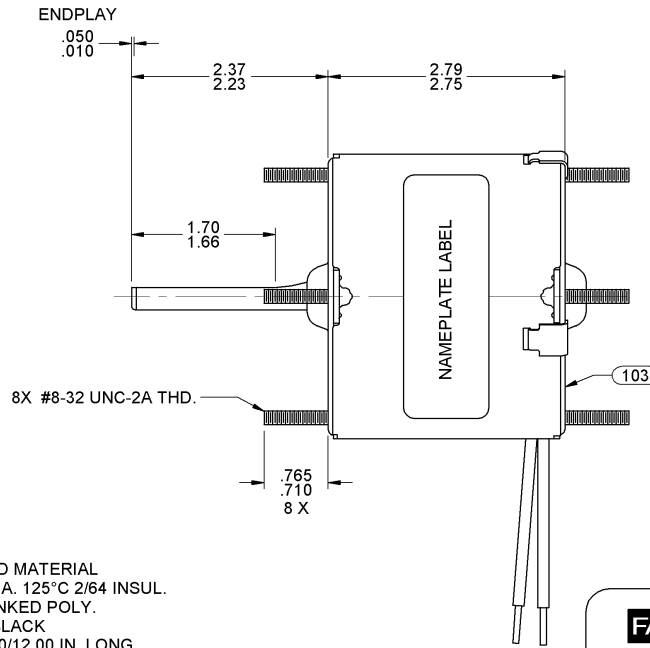
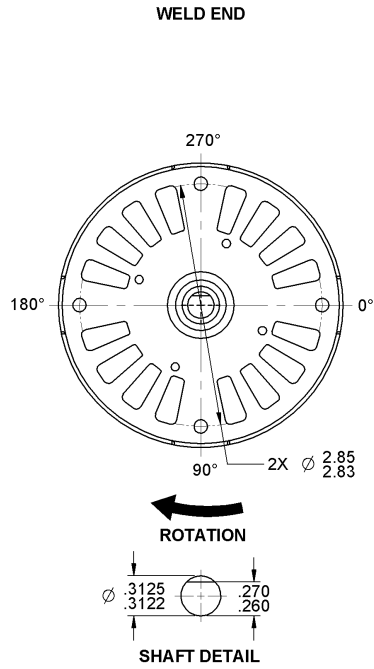

LEAD MATERIAL
18 GA. 125°C 2/64 INSUL.
X-LINKED POLY.
(2) BLACK
14.00/12.00 IN. LONG
.68/.56 IN STRIP

NOTES:
NO PACKAGING TAPE OVER CARTON LABEL.

0046-4072
0046-4282

FASCO Fasco Industries, Inc.
Motor Division

Assembled in Mexico

No. 71631855 TYPE U63B1 T.P. AO LR6319

115 V 60 Hz Class B

1.8 A 1500 RPM 1/20 HP

Model D132 Max Amb: 40°C

SAFETY WARNING

This Motor Must Be Grounded in Accordance With Local Or National Electrical Codes To Prevent Possible Injury Due To Electrical Shock

61299553

FRONT SHAFT POSITION		TYPICAL PERFORMANCE AT 115 VOLTS 60 Hz.											CUSTOMER: FASCO DISTRIBUTOR		FASCO MOTORS GROUP AC MOTOR/BLOWER DIVISION									
HORIZONTAL	MOTOR SPEED	IDLE			LOADED			LOCKED			BREAK	PART NUMBER: D132	CONFIDENTIAL; DO NOT DUPLICATE OR DISCLOSE TO THIRD PARTIES WITHOUT WRITTEN PERMISSION OF FASCO MOTORS GROUP, AC MOTOR/BLOWER DIVISION.											
		R.P.M.	AMP.	WATT	IN.OZ.	R.P.M.	AMP.	WATT	IN.OZ.	AMP.	WATT	IN.OZ.	MOTOR TYPE					DRAWING NUMBER						
		1755	1.50	81	30.0	1580	1.83	123	10.8	2.18	186	36.0	APPLICATION: COUNTER SALES	SHADED POLE					7163 1855					
													MOTOR WEIGHT: 3.22 POUNDS	ENVIRONMENT: DRY					REV. 54					
													ENVIRONMENT: DRY	B	LA	FR	A	S	C	E	B	A	REV.	
													FINISH COLOR: BLACK	00	63	30	V	05	FI	5	3	0	54	
													DRAWN BY: HELEN SHORT											
													DATE DRAWN: AUGUST 13, 2001											