







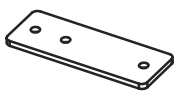
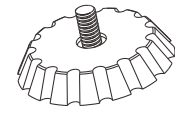

Ergo2 Series L Shape Desk - Assembly Instruction

SCREW ACCESSORIES

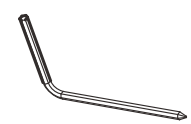
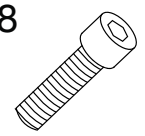
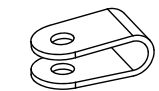
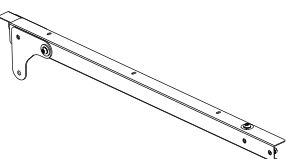
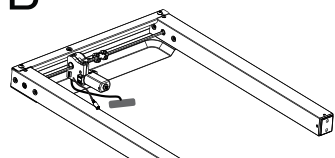
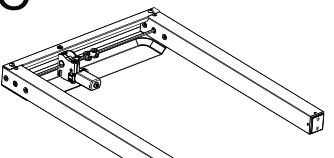
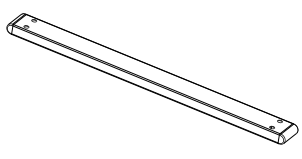
<p>S1</p>  <p>Bracket & Motor Screw (M8) x16</p>	<p>S2</p>  <p>Wood Screw (M4) x28</p>	<p>S3</p>  <p>Table Top Connector x2</p>	<p>S4</p>  <p>Footer x4</p>	<p>S5</p>  <p>Cable Hook x3</p>	<p>S6</p>  <p>3mm Allen Key x1</p>
<p>S7</p>  <p>6mm Allen Key x1</p>	<p>S8</p>  <p>Foot Base Screw (M8) x8</p>	<p>S9</p>  <p>Wire Hook x4</p>			

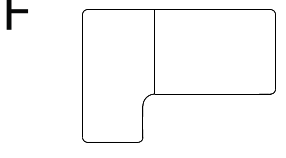
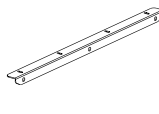
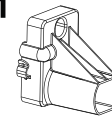
PARTS ACCESSORIES

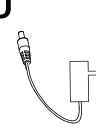
<p>A</p>  <p>Central Bracket x2</p>	<p>B</p>  <p>Left Side Frame with Motor x1</p>	<p>C</p>  <p>Right Side Frame with Motor x1</p>	<p>D</p>  <p>Short Foot Base x1</p>		
<p>E</p>  <p>Long Foot Base x1</p>	<p>F</p>  <p>Table Top x1</p>	<p>G</p>  <p>Left Side Bracket x1</p>	<p>H</p>  <p>Motor Cover x2</p>	<p>I</p>  <p>Motor Cable x1</p>	<p>J</p>  <p>Power Cord x1</p>

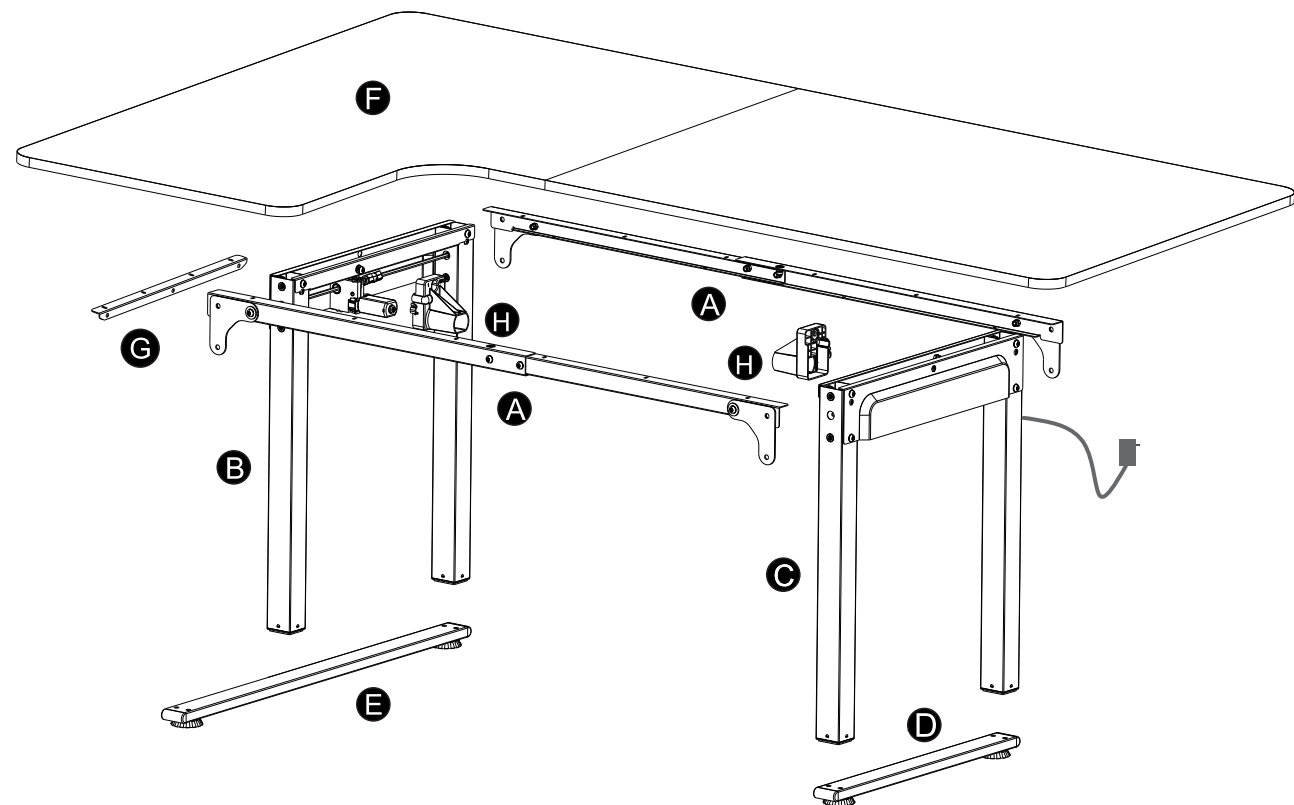

STEP 1

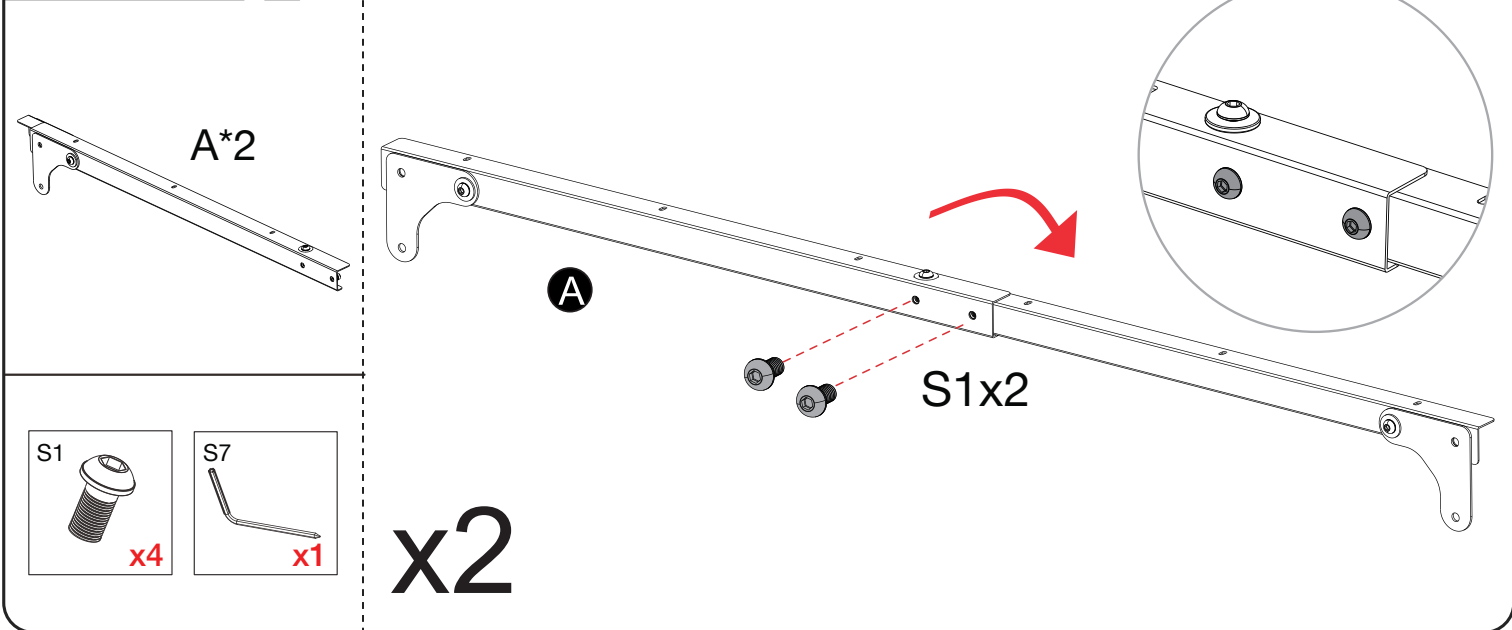

STEP 2

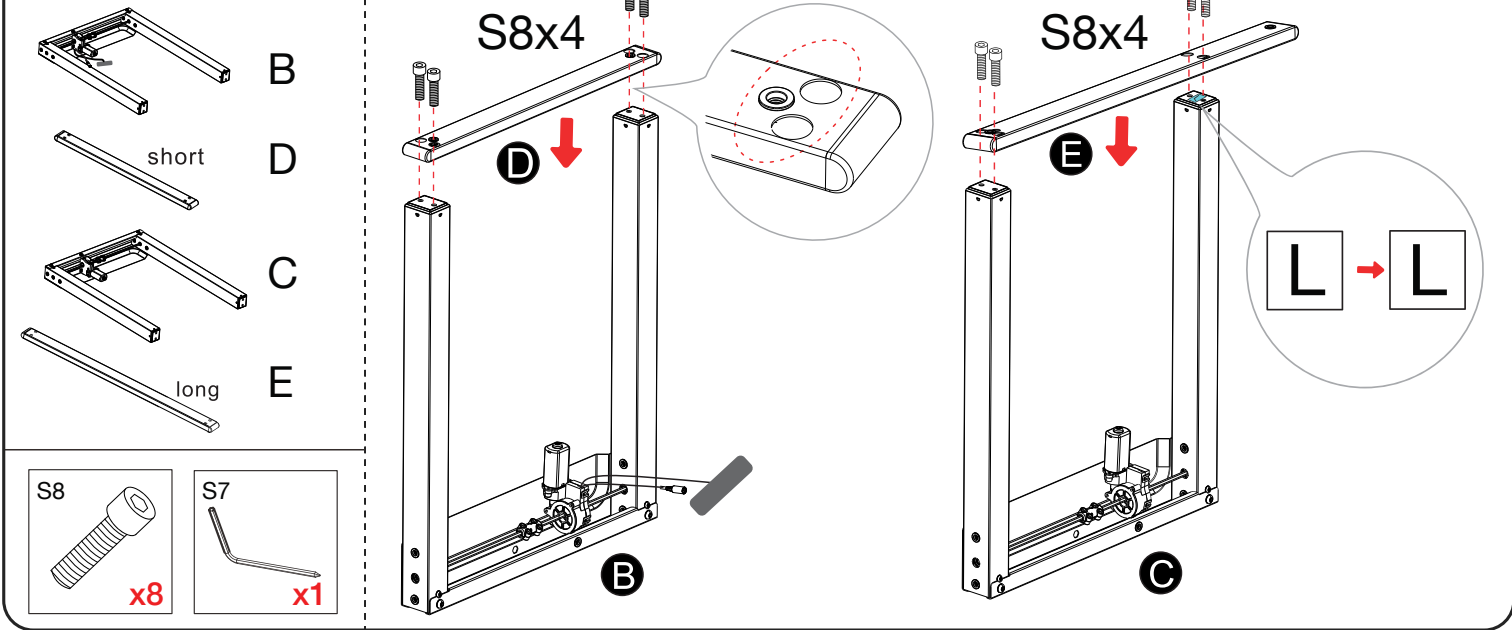

STEP 3

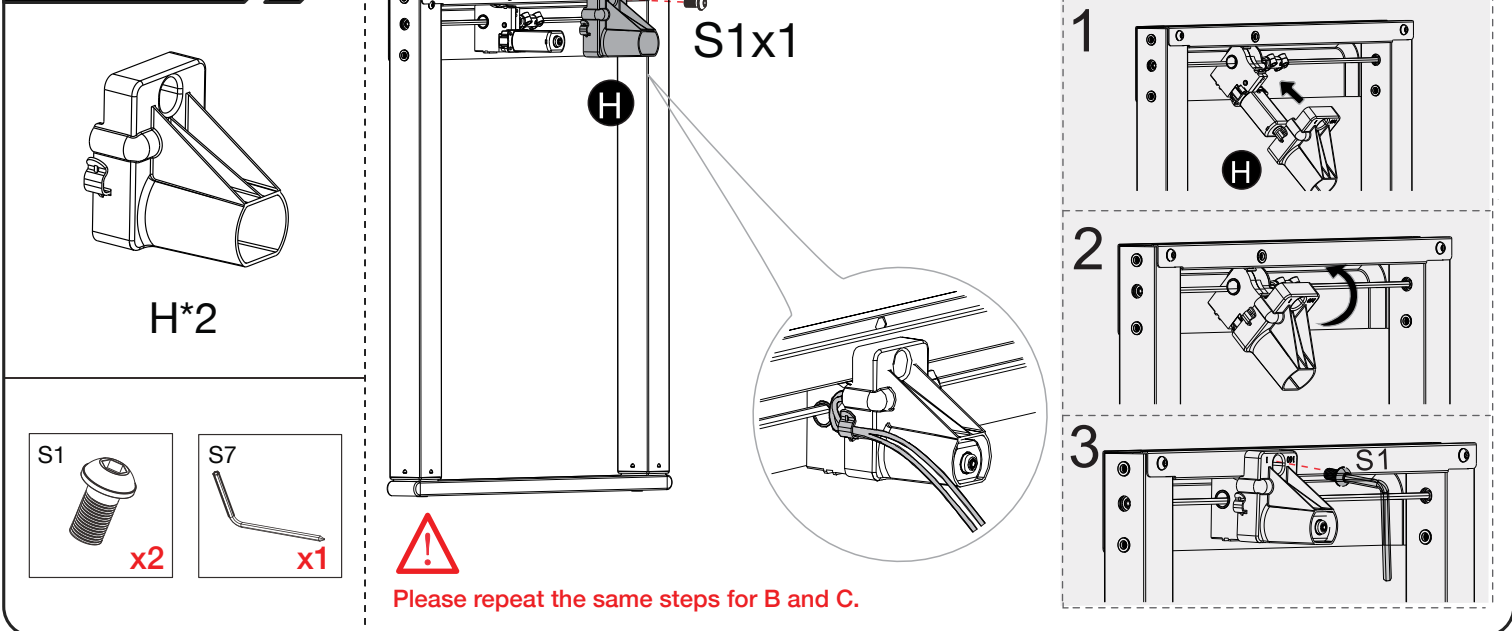

STEP 4

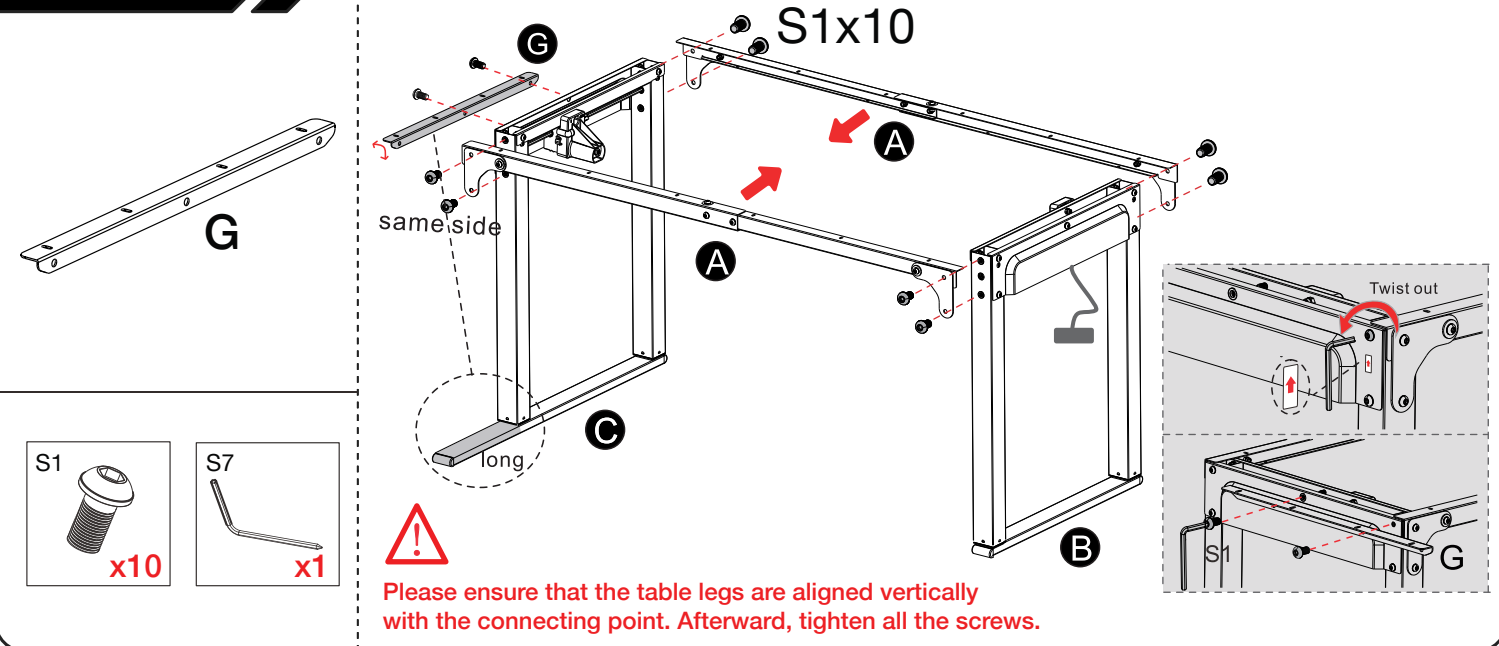

STEP 5

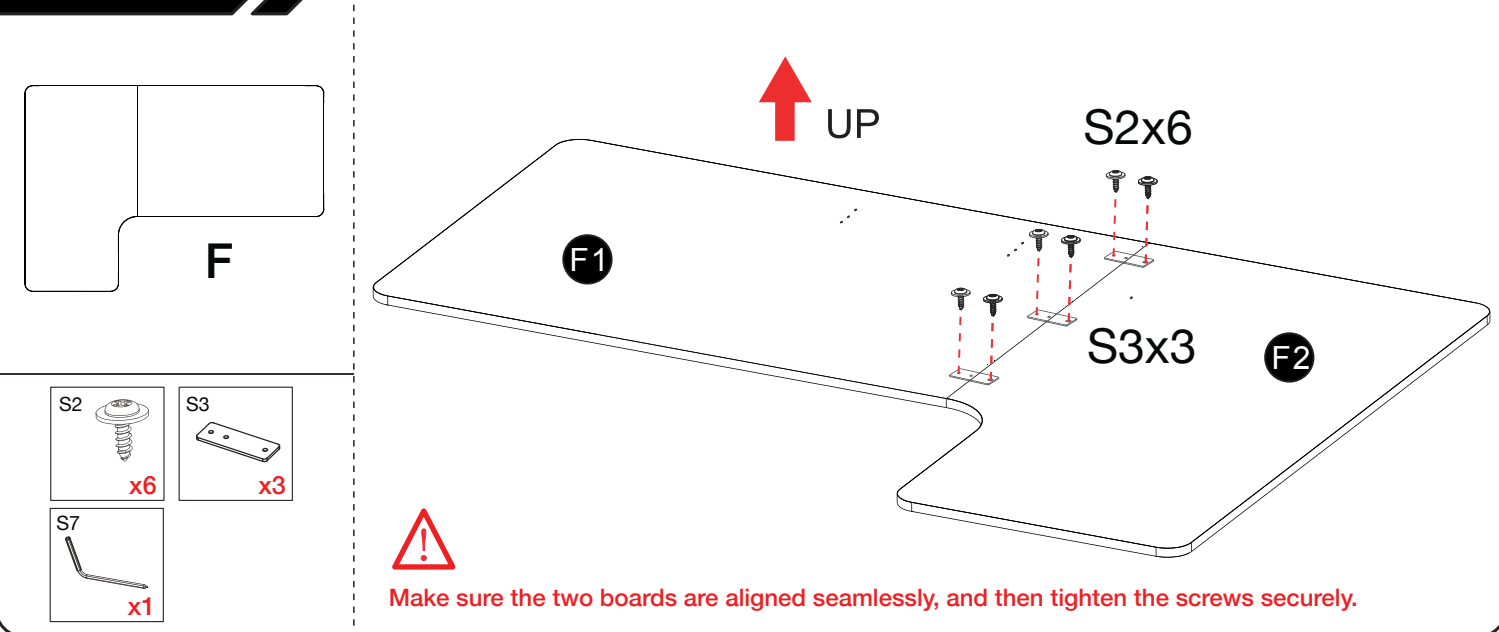

STEP 6

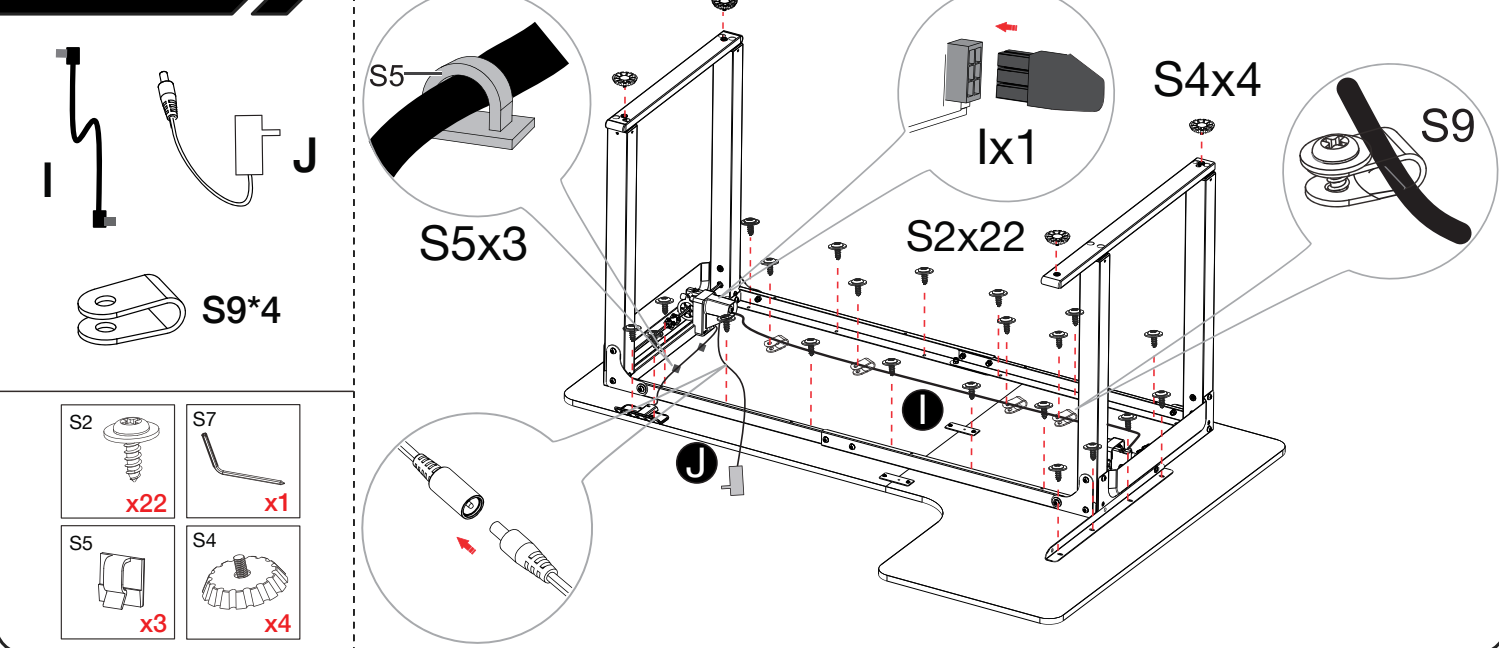

STEP 7

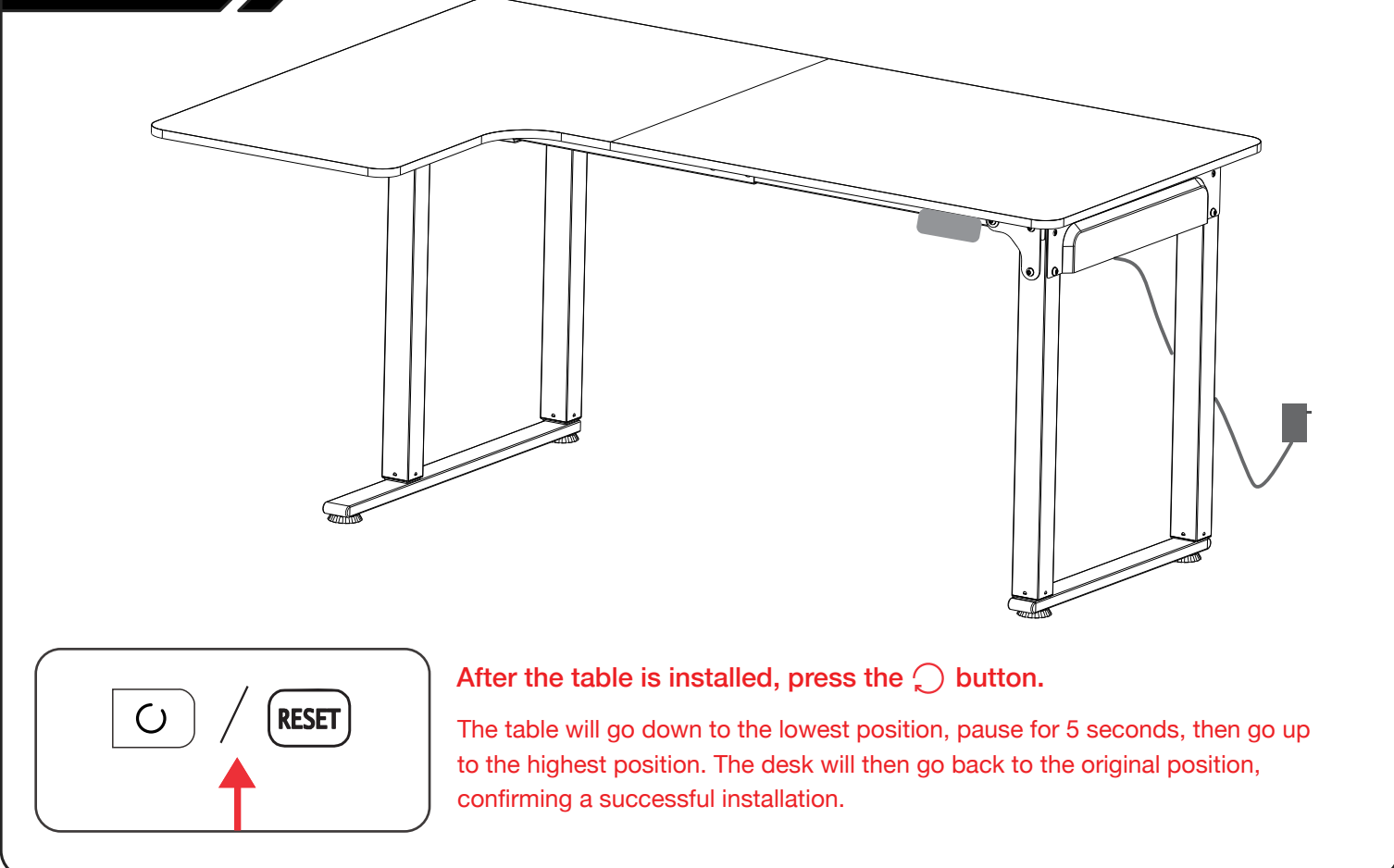

Instruction Manual

UP: Up Button	RST: Reset Button	STAND: Saving Button 1
DOWN: Down Button		SIT: Saving Button 2

UP and DOWN Button Operation

- Press the “” button to raise the desk.
- Press the “” button to lower the desk.
- Press and hold the “” or “” button for 3 seconds, then release it, to automatically raise or lower the desk to the highest or lowest position.
- While the desk is raising or lowering, you may press any button to stop the desk.

Height Position Memory Operation

- Storage of standing position: Press and hold the “” button for 5 seconds to save the current standing position.
- Storage of sitting position: Press and hold the “” button for 5 seconds to save the current sitting position.

Reset Operation

- Press and hold the “ / ” button for 5 seconds. The table will descend to the lowest position, Pause for 5 seconds, then rise to the highest position. The desk will then return to the initial position.