

Eco Mesh High Back Chair - Assembly Instruction

PARTS AND SCREW ACCESSORIES

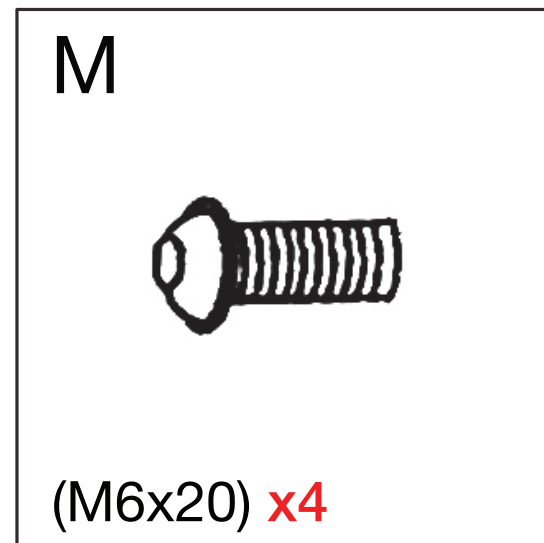
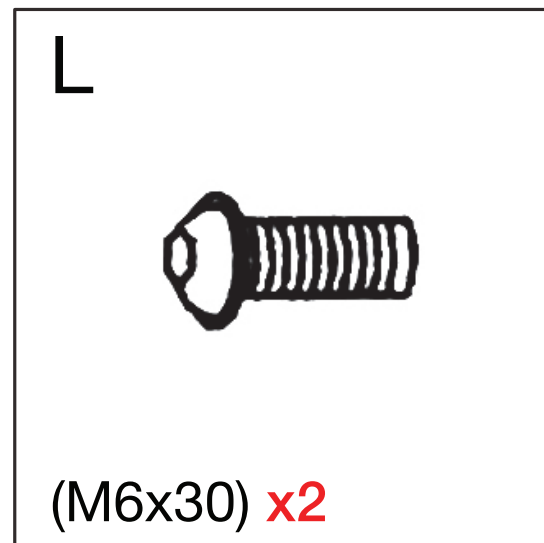
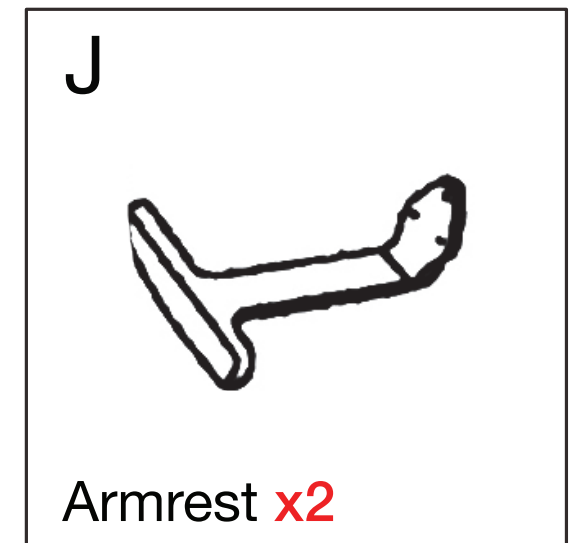
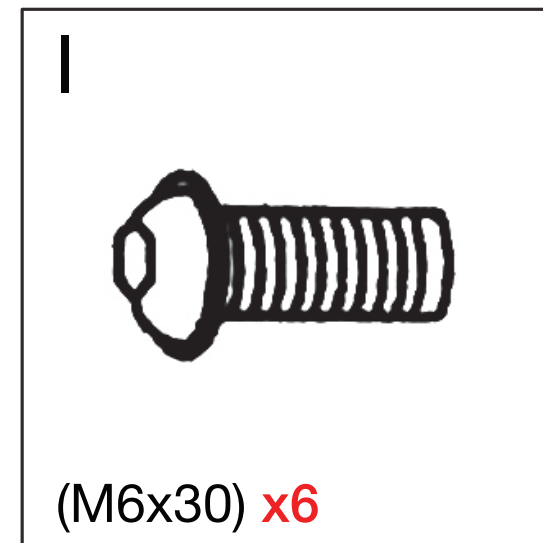
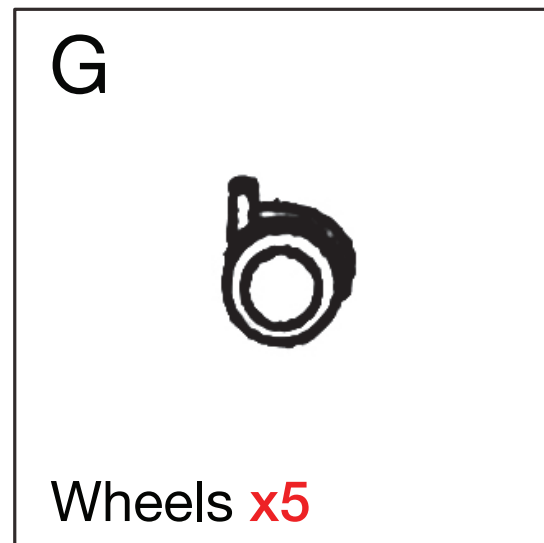
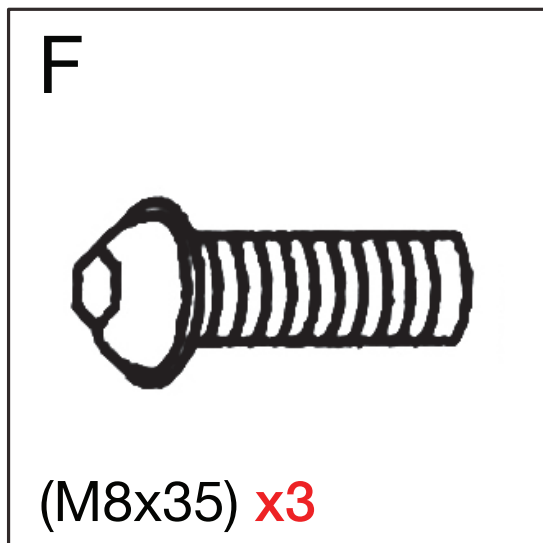
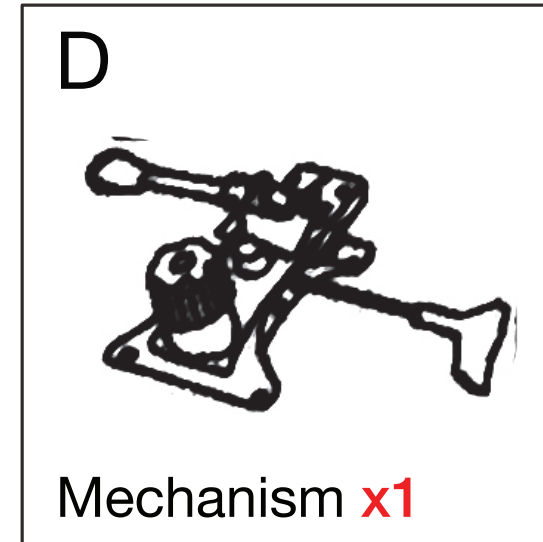
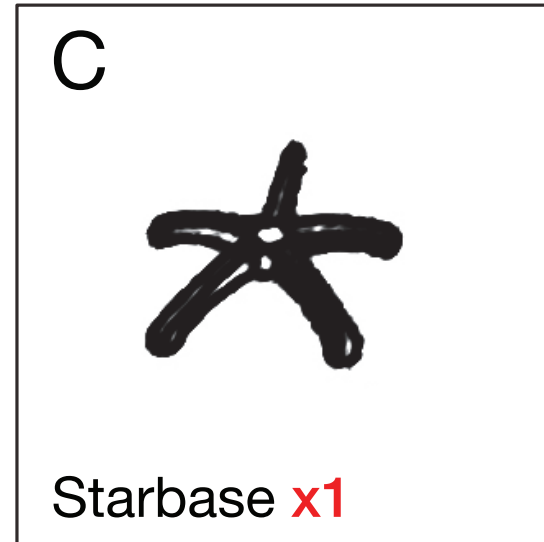
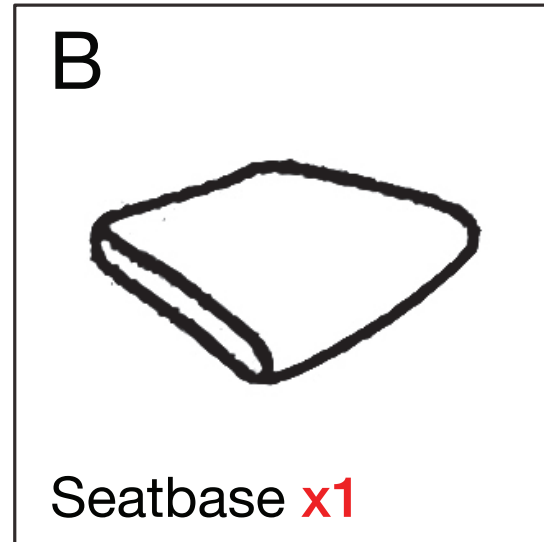
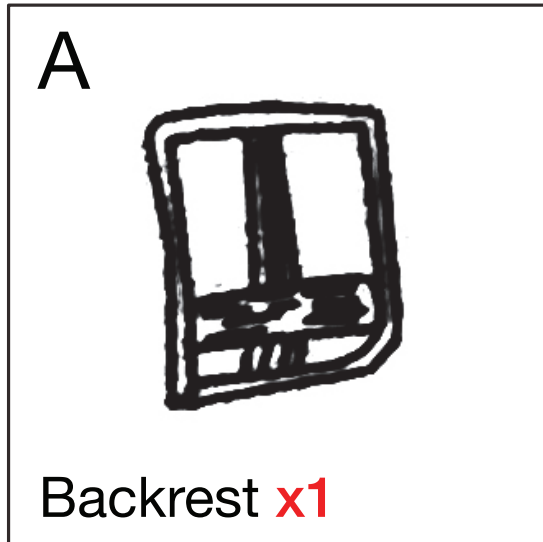

STEP 1

Attach the backrest, seatbase and armrest to the mechanism using the screws and allen key.

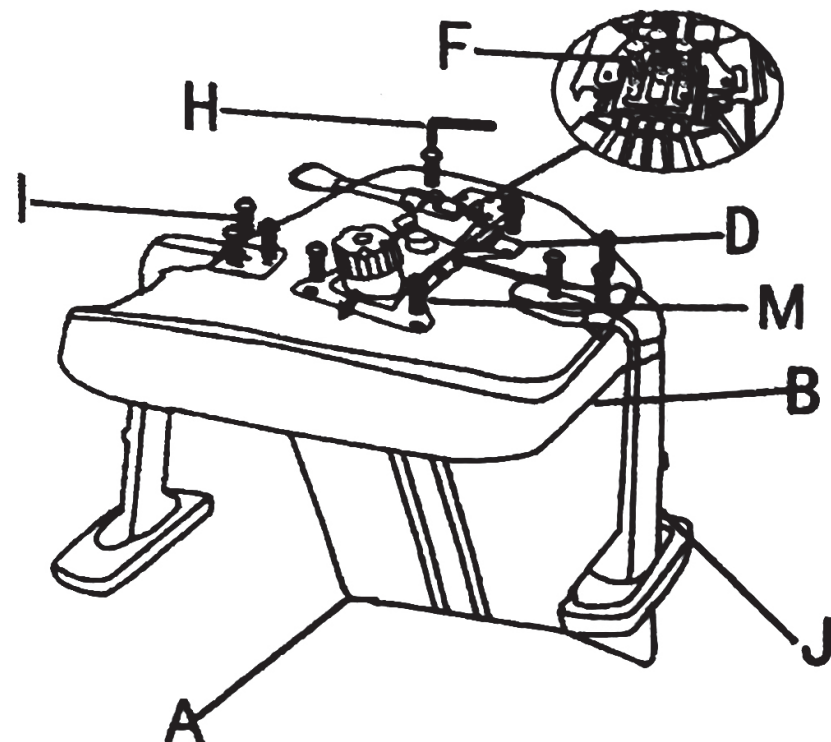

STEP 2

Insert and secure the headrest into the backrest using the screws and allen key.

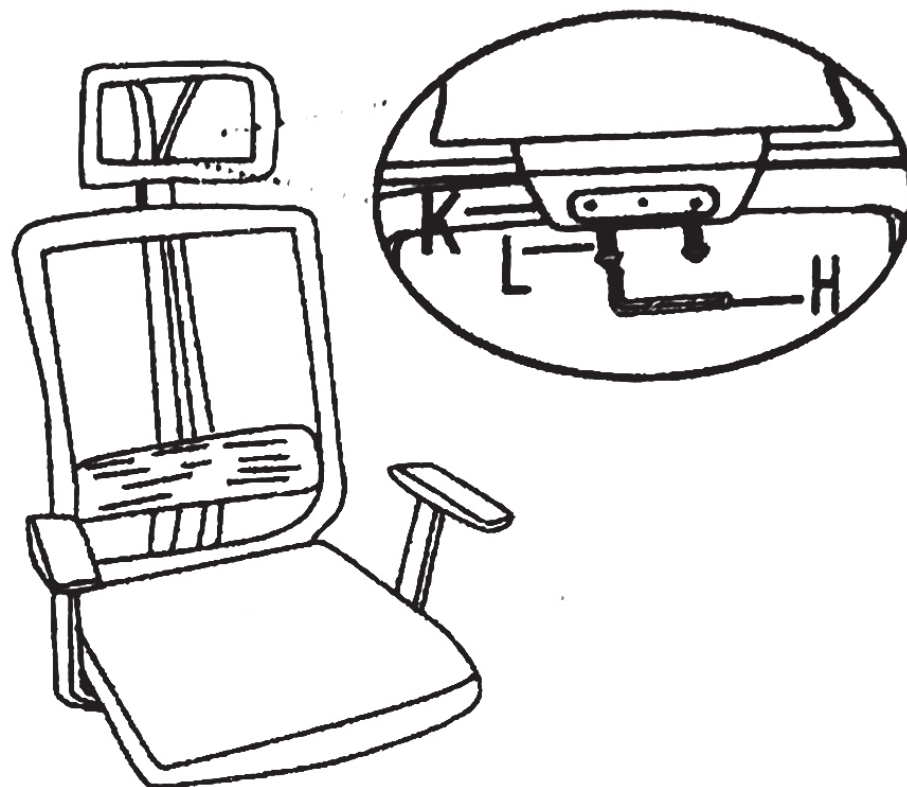

STEP 3

Attach the wheels to the starbase.

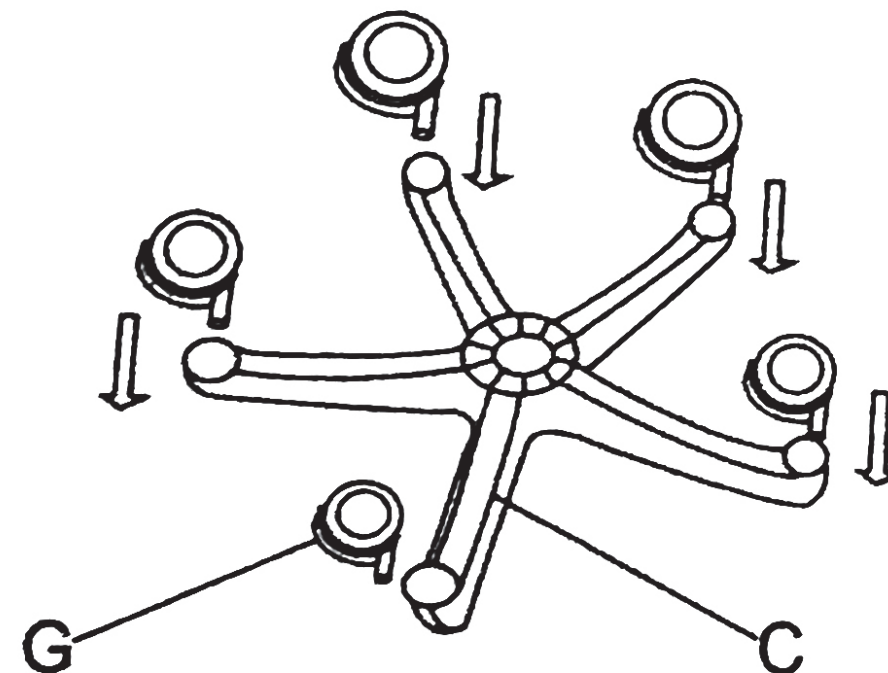

STEP 4

Insert the gas lift piston into the starbase.

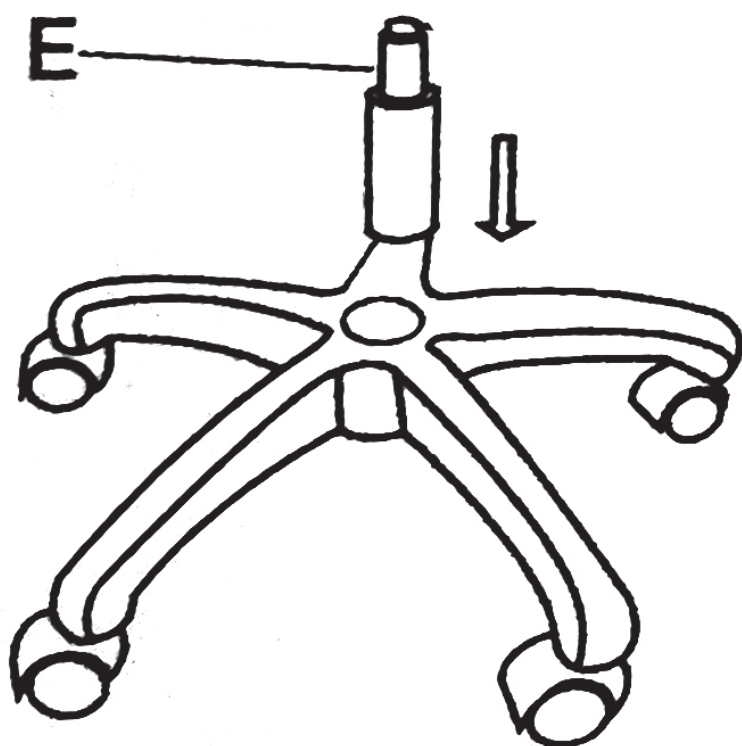

STEP 5

Attach the assembled mechanism to the gas lift piston.

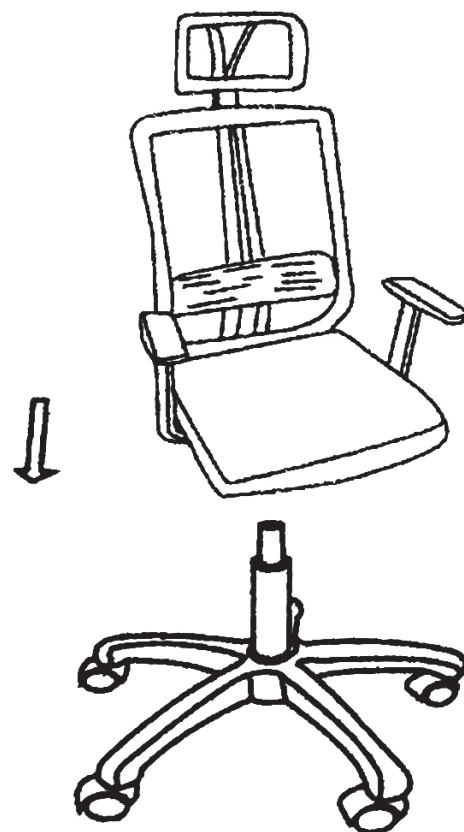

STEP 6

Double-check everything in a final inspection.

