

WATCH SIZE GUIDE

Use this chart to see which watch sizes fit you best. Just print at 100%, cut out the sizes you're considering, and hold up to your wrist to find the perfect fit.

PRINT INSTRUCTIONS

1. Open this PDF in Adobe Acrobat Reader
2. Select Print and check Print Settings
3. Select "actual size" or "turn off scaling" or "set scaling to 100%" depending on your options.
4. This will ensure your chart prints with accurate sizing.

To ensure accuracy, the line below should measure exactly 40mm with a ruler

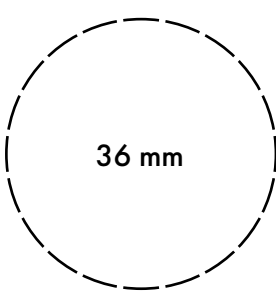

36 mm

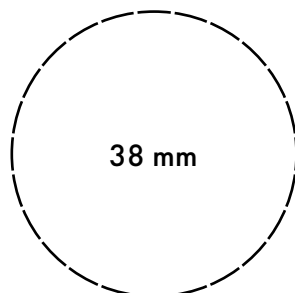

38 mm

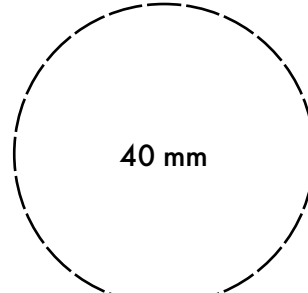

40 mm

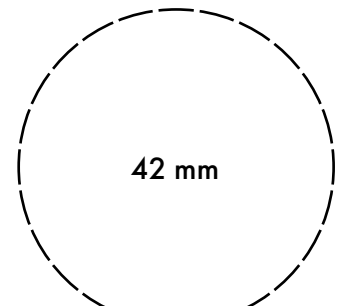

42 mm

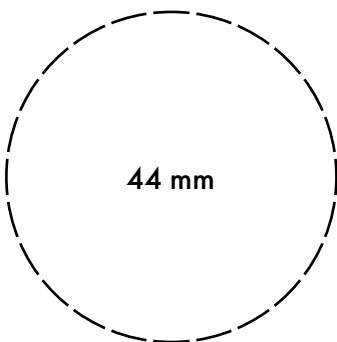

44 mm

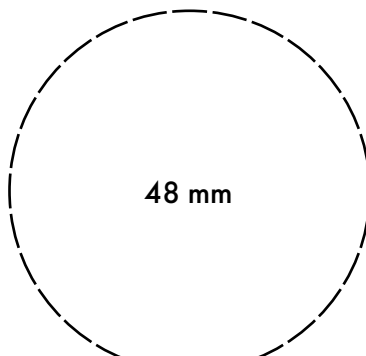

48 mm

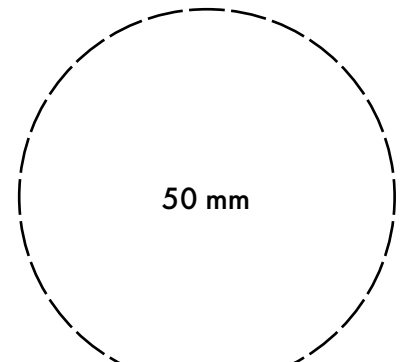

50 mm

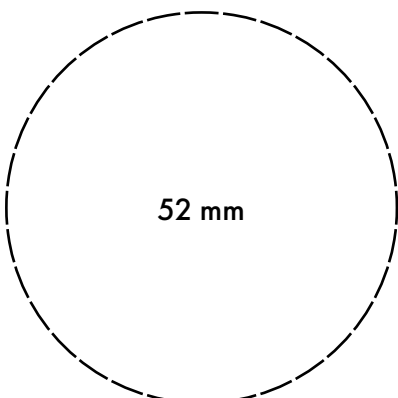

52 mm

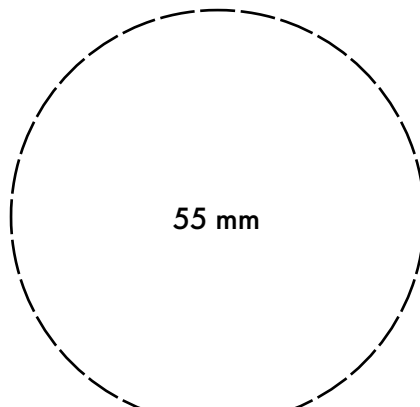

55 mm

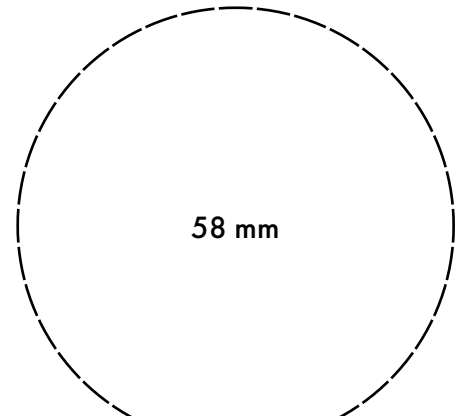

58 mm