

Power management ¶

Different parts of the board requires different voltages to operate and to fulfill requirements of all the chips on BeaglePlay we have Low Drop Out (LDO) voltage regulators for fixed voltage output and Power Management Integrated Circuit (PMIC) that interface with SoC to generate software programmable voltages. 2 x LDOs and 1 x PMIC used on BeaglePlay are shown below.

TLV75801 - LDO

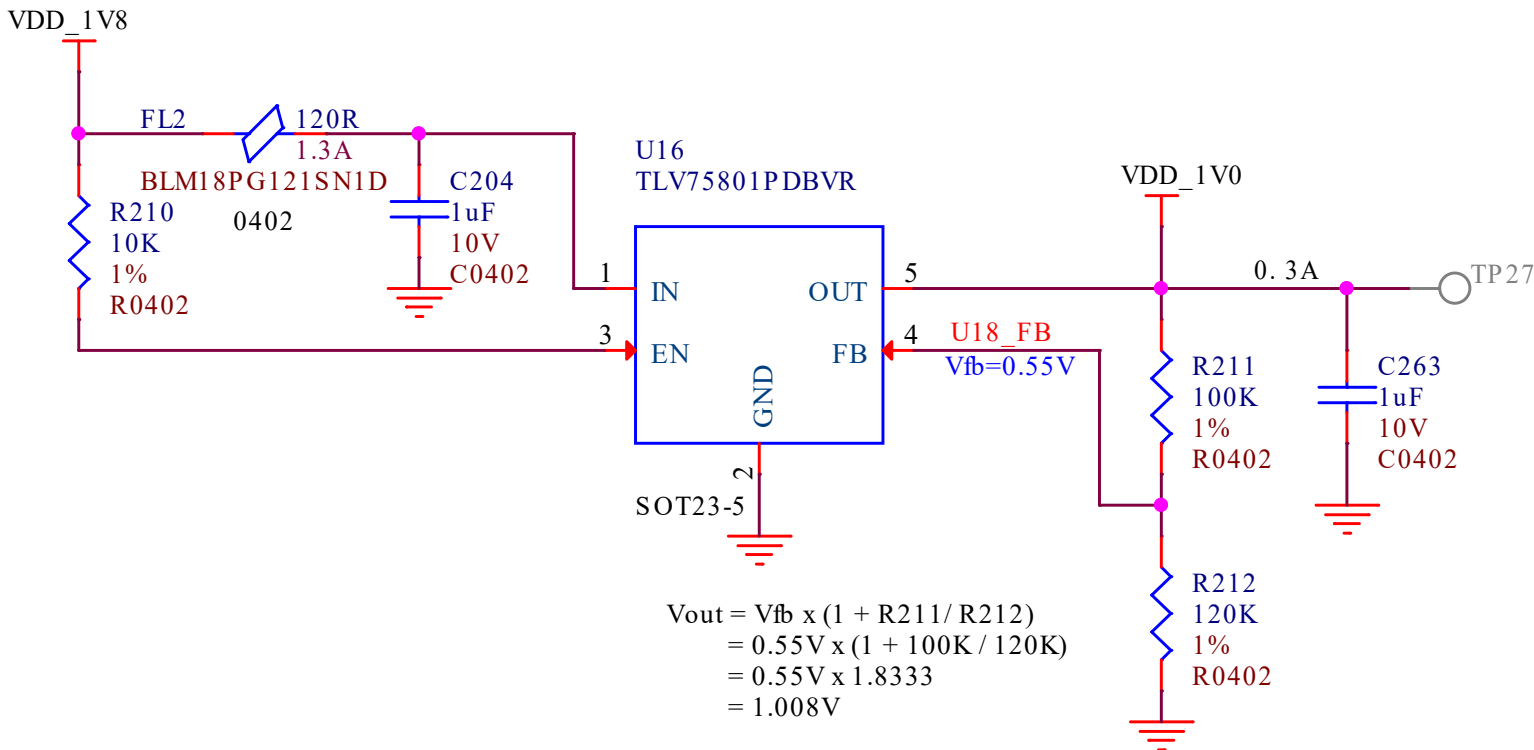

Fig. 6 TLV75801PDBVR LDO schematic for 1V0 output

TLV62595 - LDO

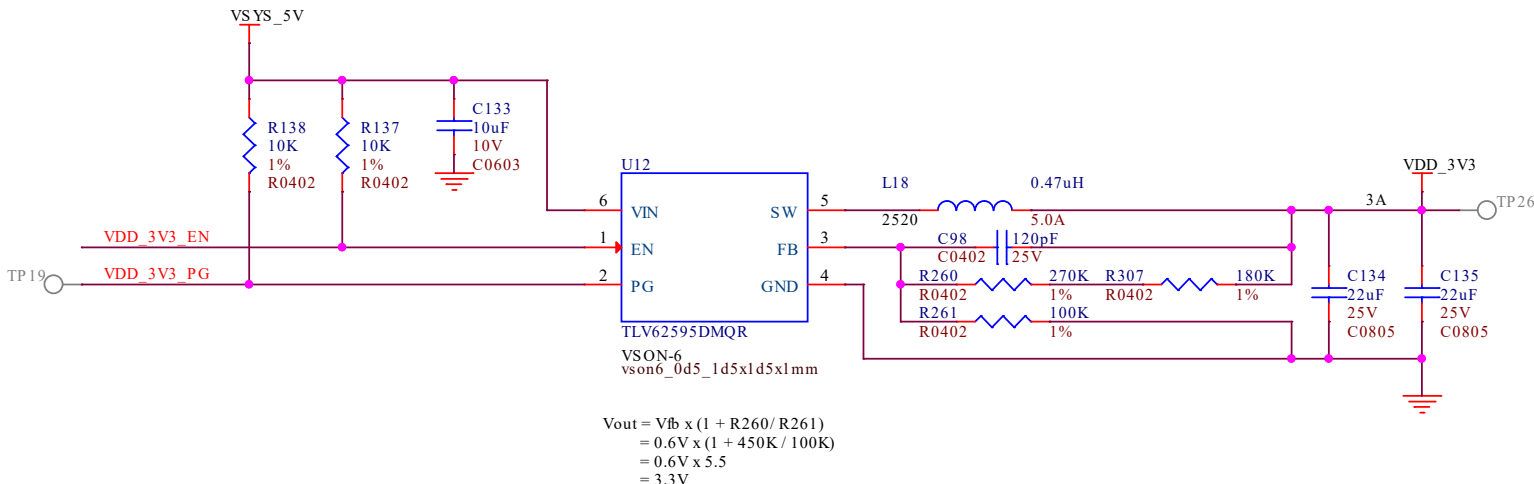

Fig. 7 TLV62595DMQR LDO schematic for 3V3 output

TPS65219 - PMIC

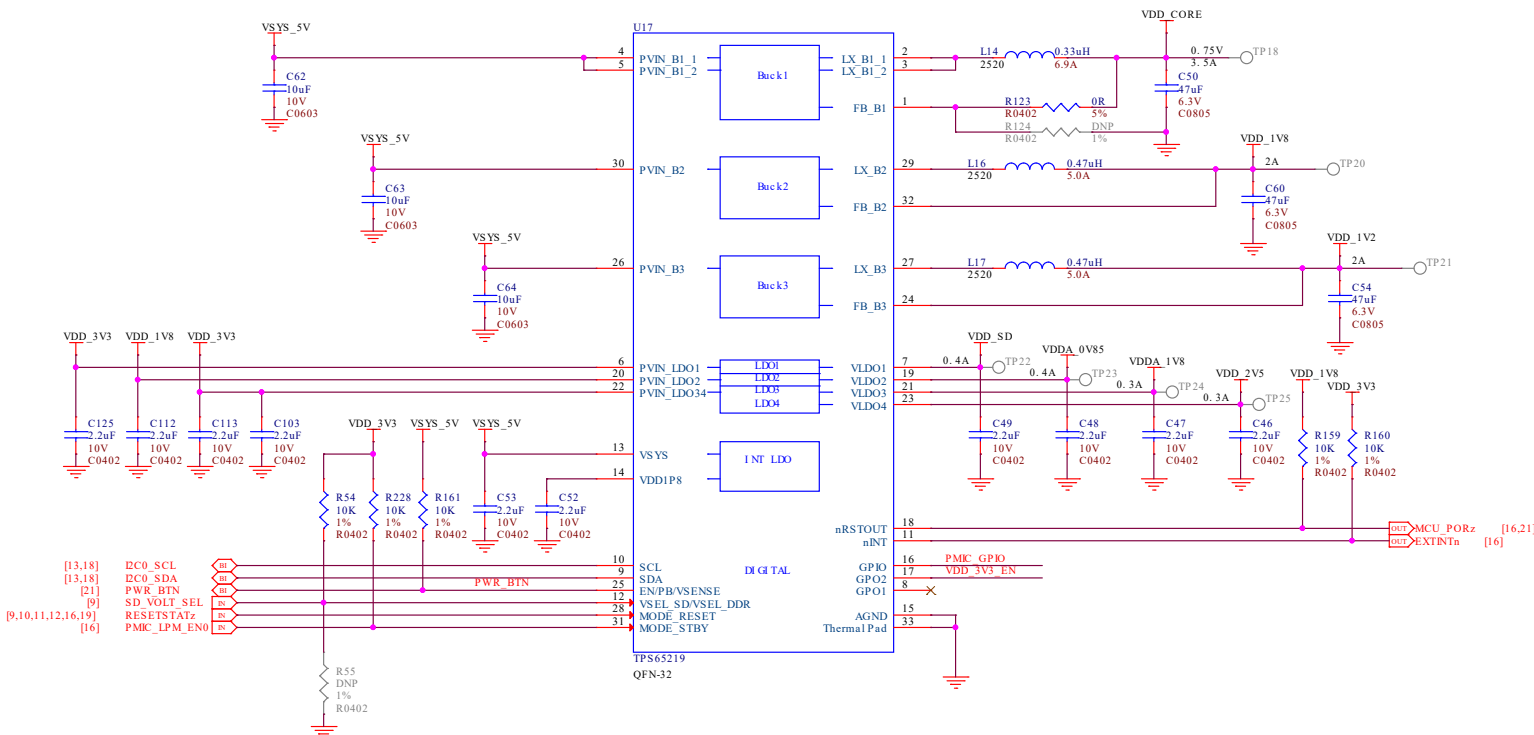

Fig. 8 TPS65219 Power Management Integrated Circuit (PMIC) schematic

General Connectivity and Expansion

One of the main advantage of using a Single Board Computer (SBC) is having direct accessibility of general purpose input & output (GPIO) pins and other interfaces like I2C, SPI, ADC, PWM. Your BeaglePlay board shines in this domain as well with mikroBUS connector that can take 1000s of click board from [MikroElektronika](#), Grove connector allows to connect hundreds of Grove modules from [Seeed Studio](#), and QWIIC connector allows to connect I2C modules like QWIIC modules from [SparkFun](#) or STEMMA QT modules from [Adafruit](#). Note that you also get one USB-A port and one USB-C port. BeaglePlay's USB-A port with host support enables you to connect any USB device like your keyboard & mouse. The USB-C connector allows you to power the board and to connect the board to a PC. You can then connect via SSH or use the pre-installed VisualStudio Code editor by putting the address `192.168.7.2:3000` in your web browser.

USB A & USB C

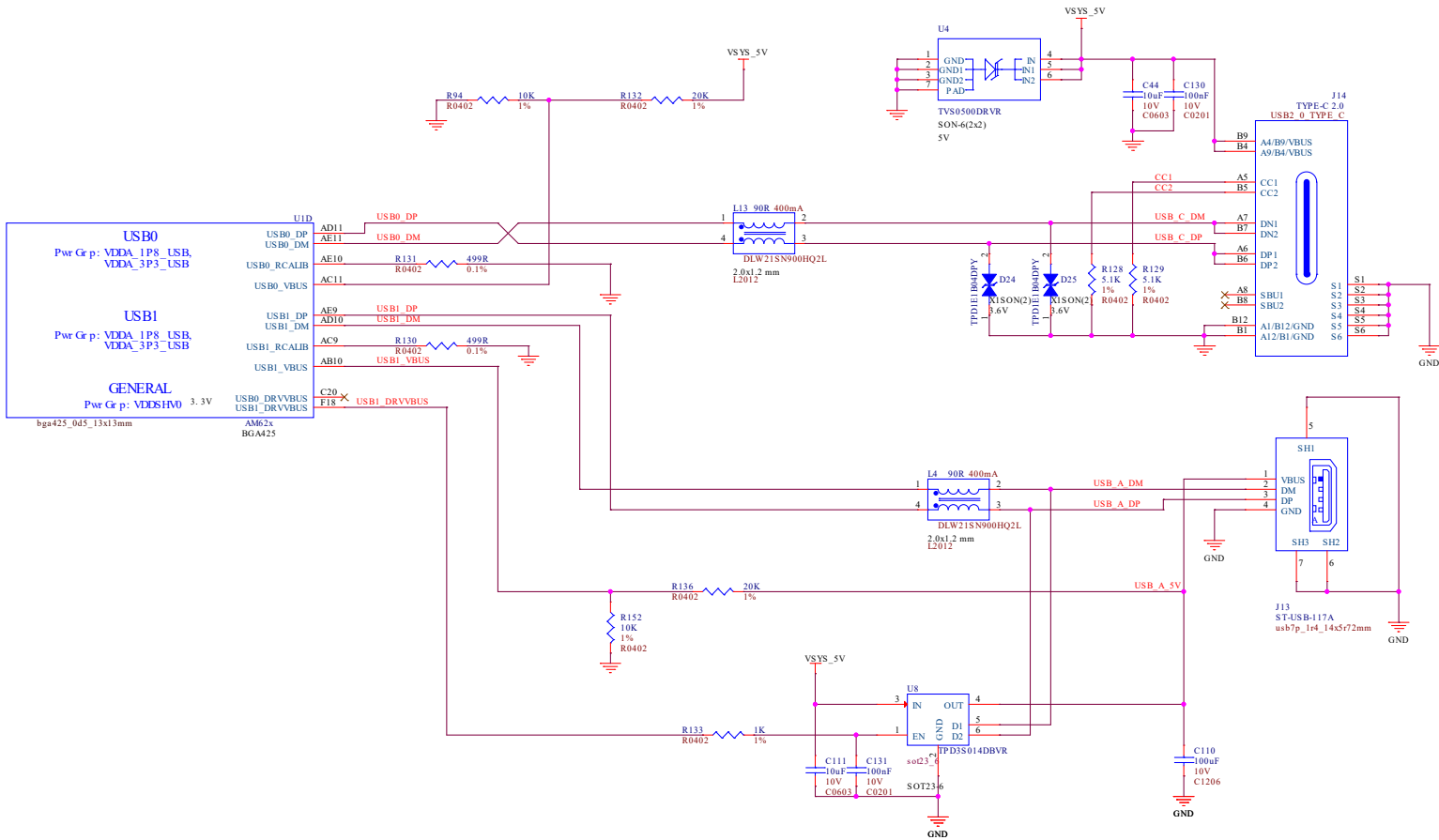

Fig. 9 USB-A and USB-C

ADC102S051 - 2ch 10bit ADC

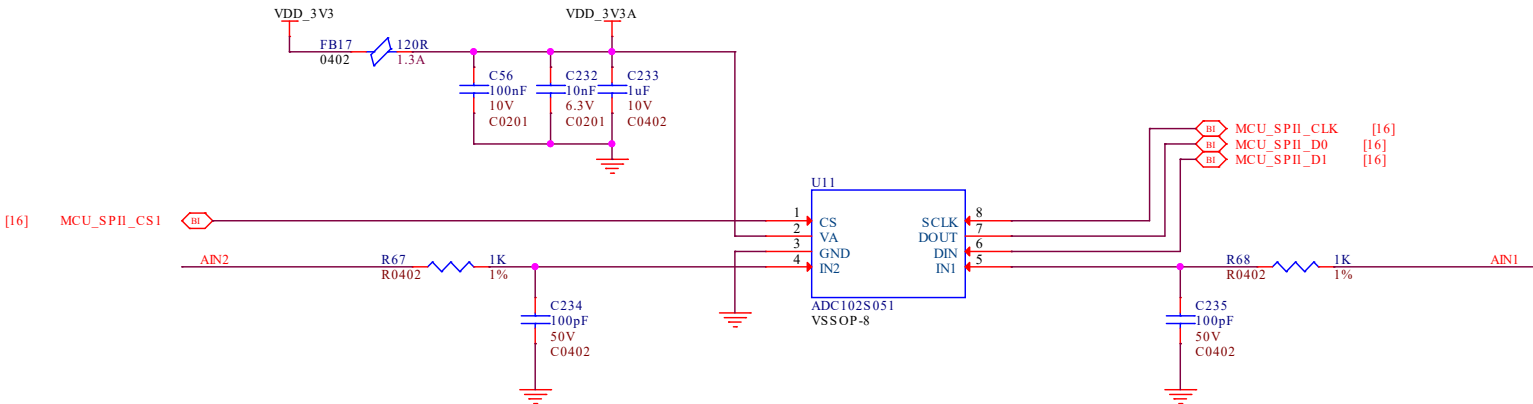

Fig. 10 ADC102S051 - 12bit Analog to Digital Converter (ADC)

mikroBUS

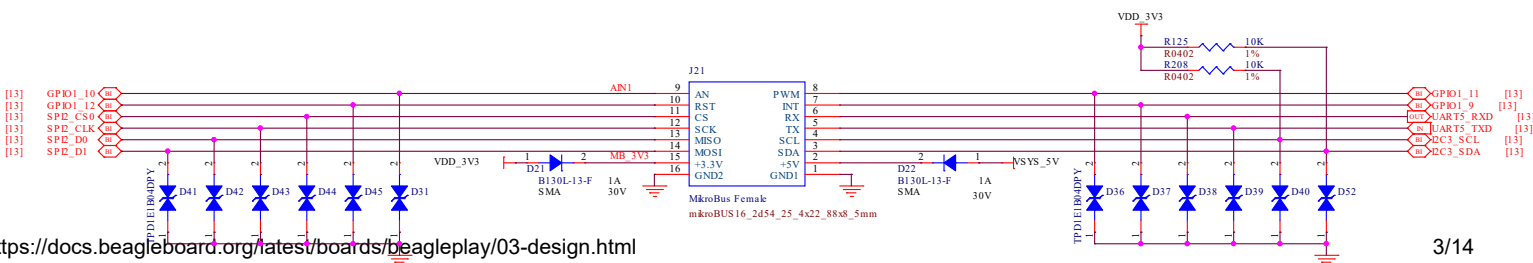

Fig. 11 mikroBUS connector schematic

Grove

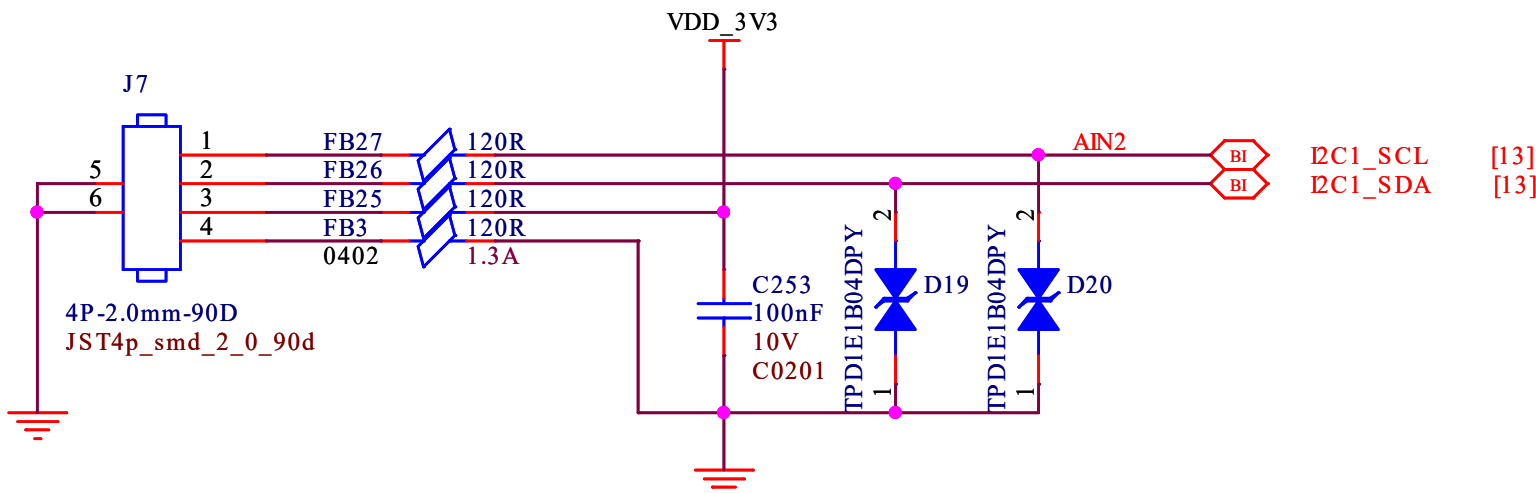

Fig. 12 Grove connector schematic

Qwiic

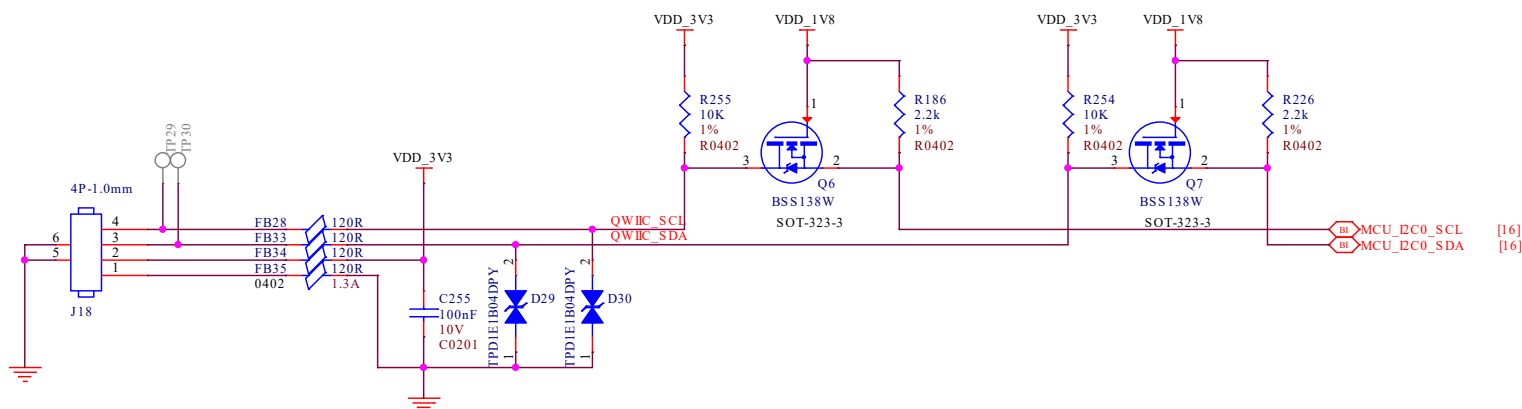

Fig. 13 QWIIC connector for I2C modules

Buttons and LEDs

To interact with the Single Board Computers we use buttons for input and LEDs for visual feedback. On your BeaglePlay board you will find 3 buttons each with a specific purpose: power, reset, and user. For visual feedback you will find 5 user LEDs near USB-C port and 6 more indicator LEDs near your BeaglePlay’s Single Pair ethernet port. Schematic diagrams below show how these buttons and LEDs are wired.

Buttons

Table 4 BeaglePlay buttons

Power	Reset	User
-------	-------	------

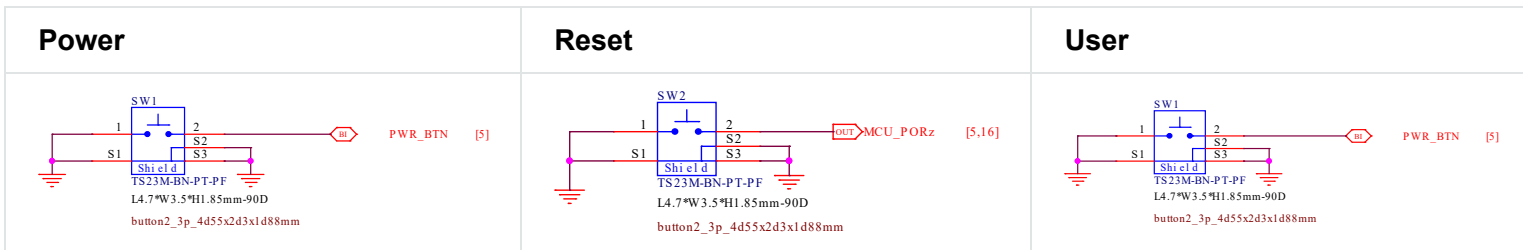

LEDs

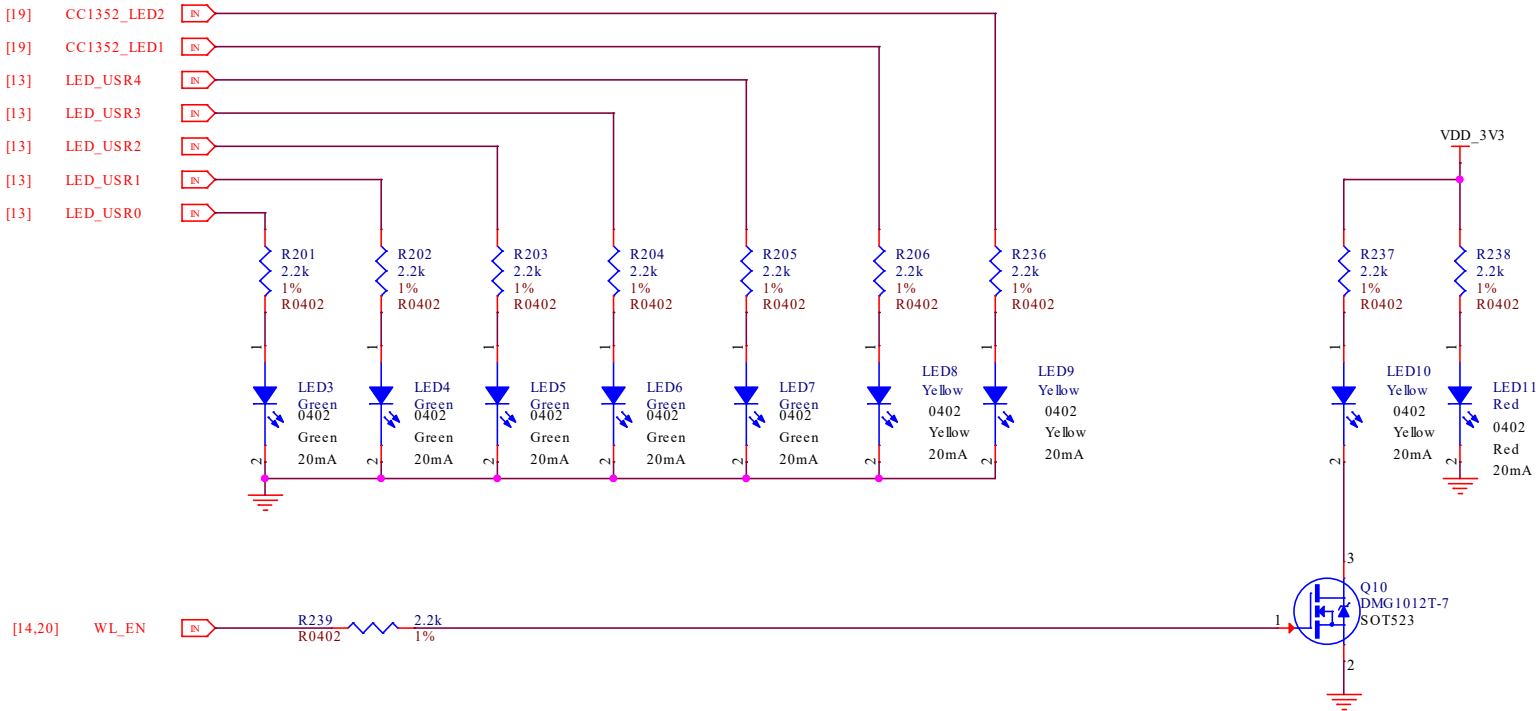

Fig. 14 BeaglePlay LEDs

WL1807MOD - WiFi 2.4G/5G

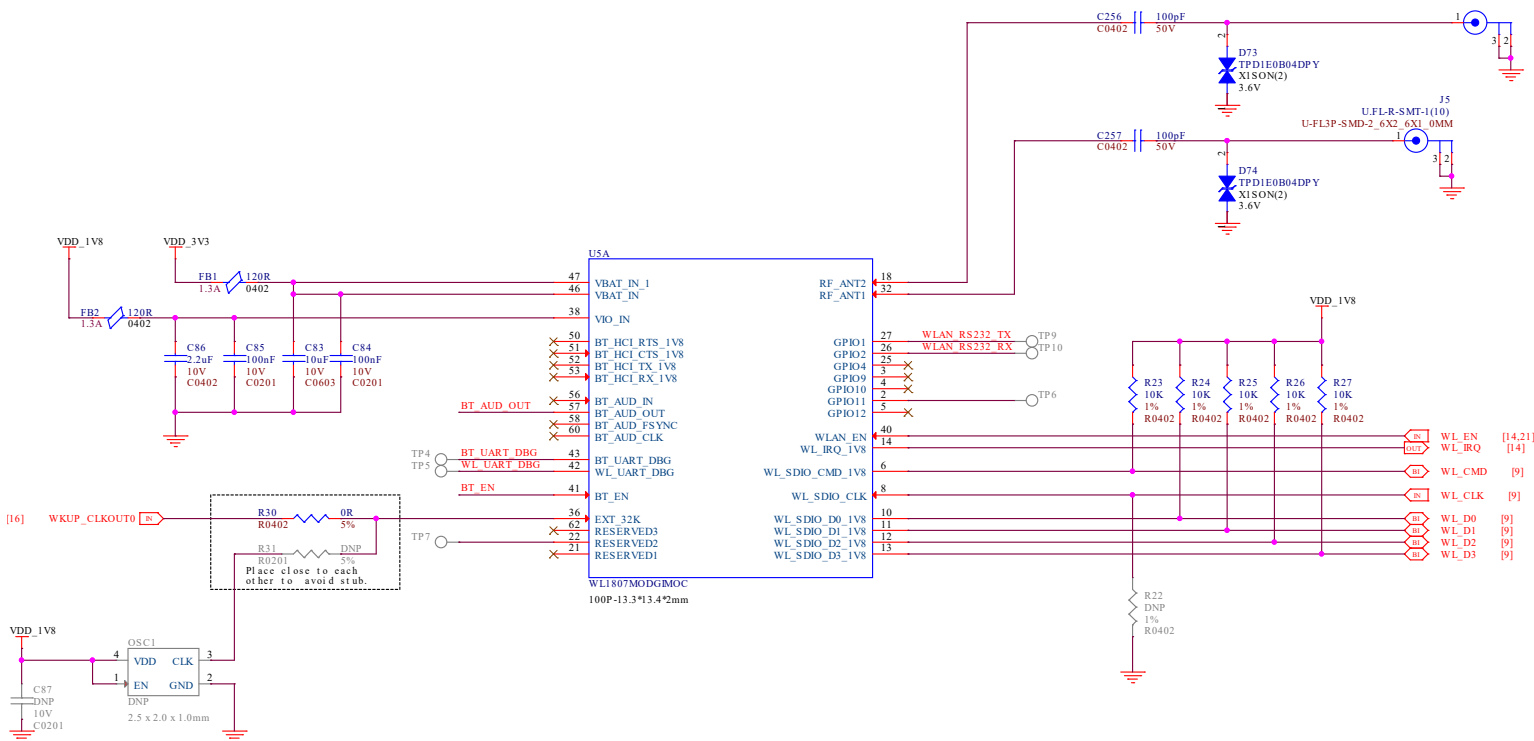

Fig. 17 WL1807MOD dual-band (2.4G/5G) WiFi

CC1352P7 - BLE & SubGHz

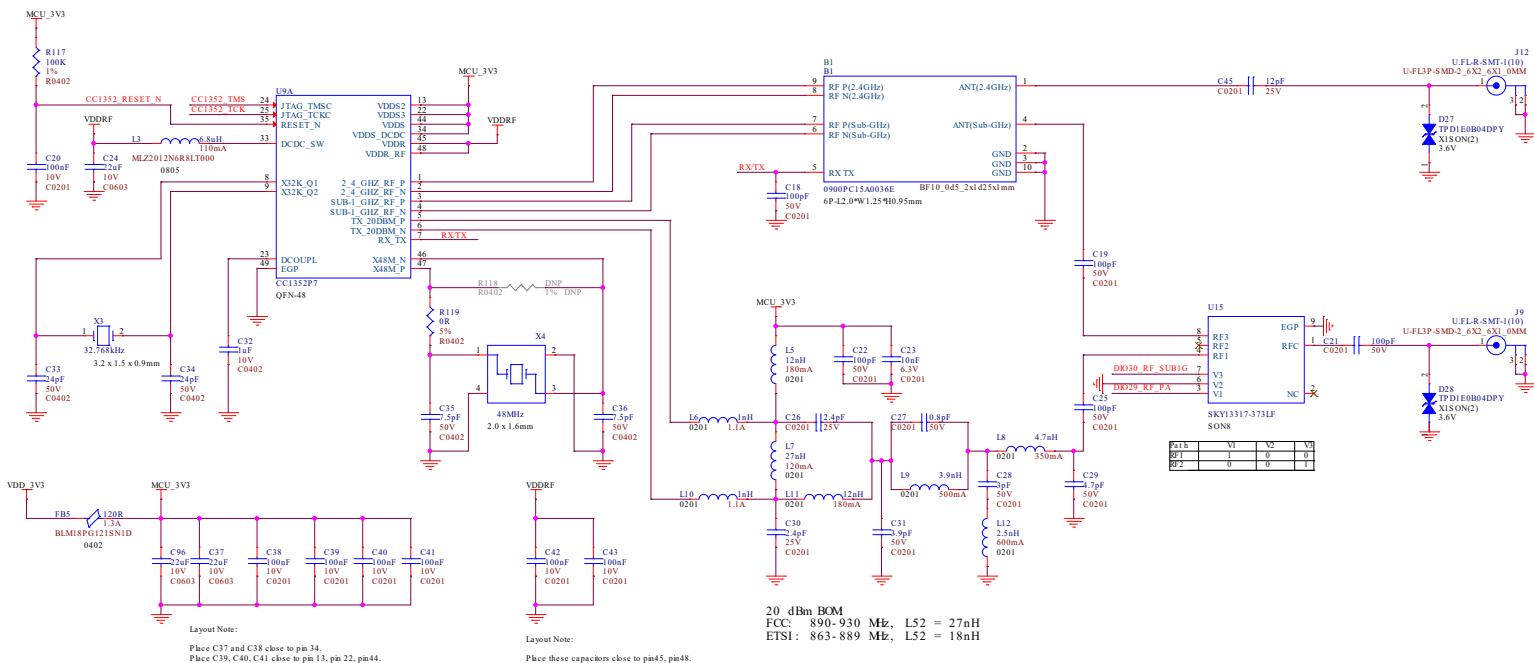

Fig. 18 CC1352P7 Bluetooth Low Energy (BLE) and SubGHz connectivity

Memory, Media and Data storage

DDR4

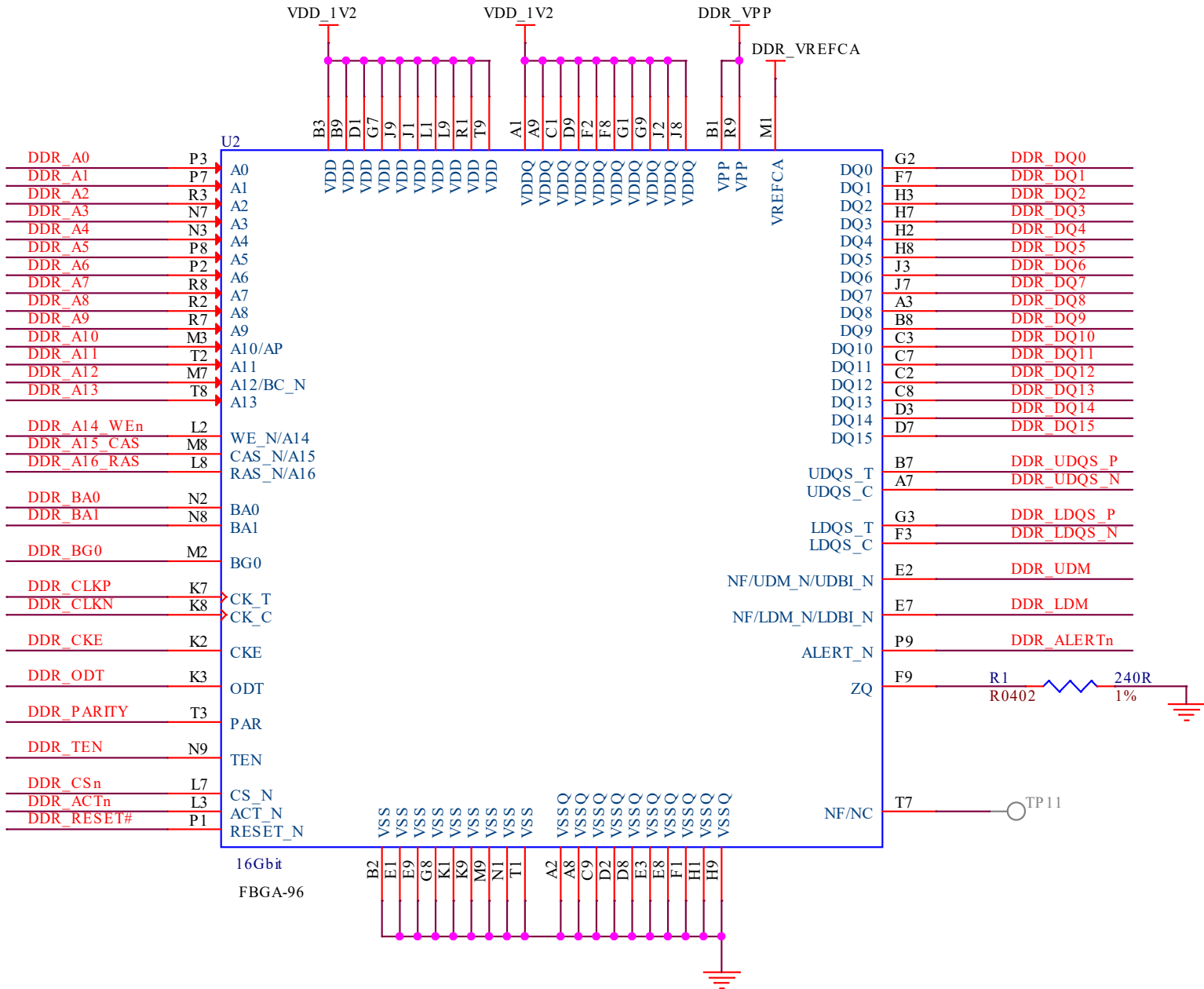

Fig. 19 DDR4 Memory

CSI

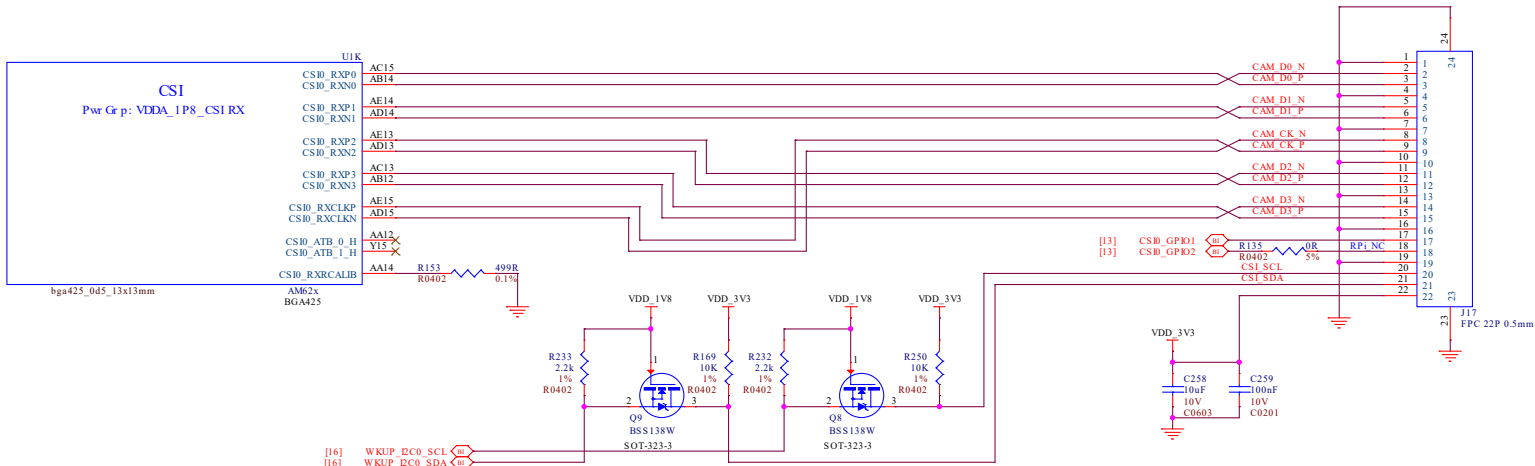

Fig. 25 CSI camera interface

RTC & Debug

RTC

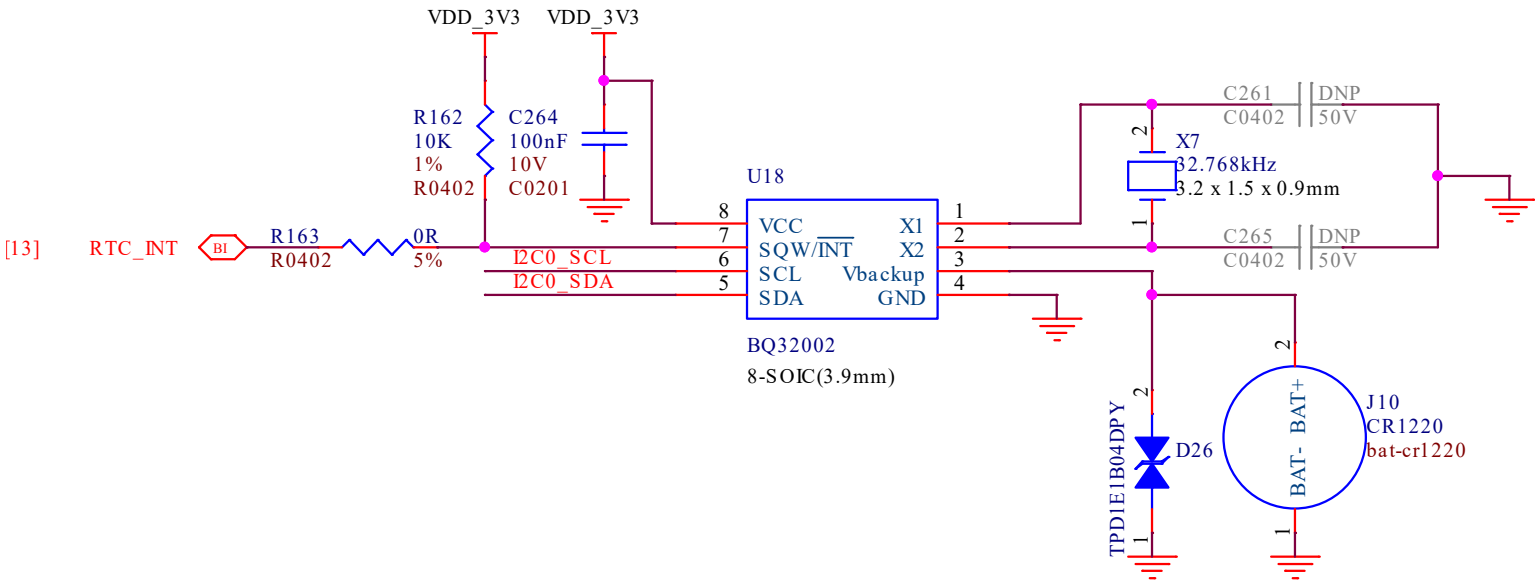

Fig. 26 Real Time Clock (RTC)

UART Debug Port

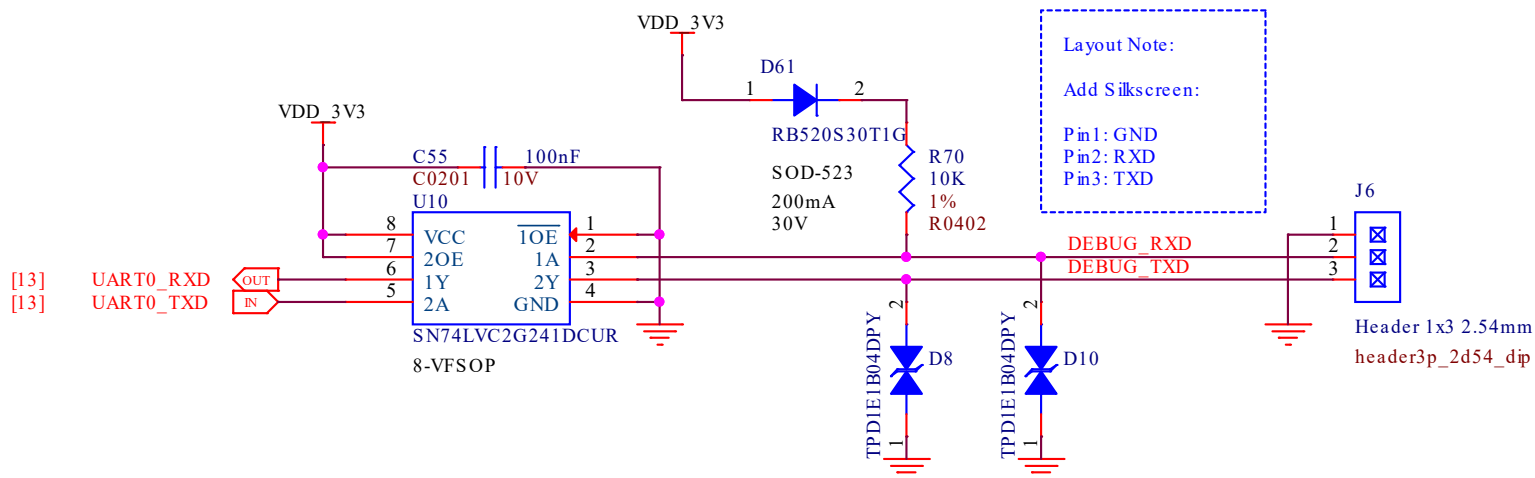

Fig. 27 UART debug port

AM62x JTAG & TagConnect

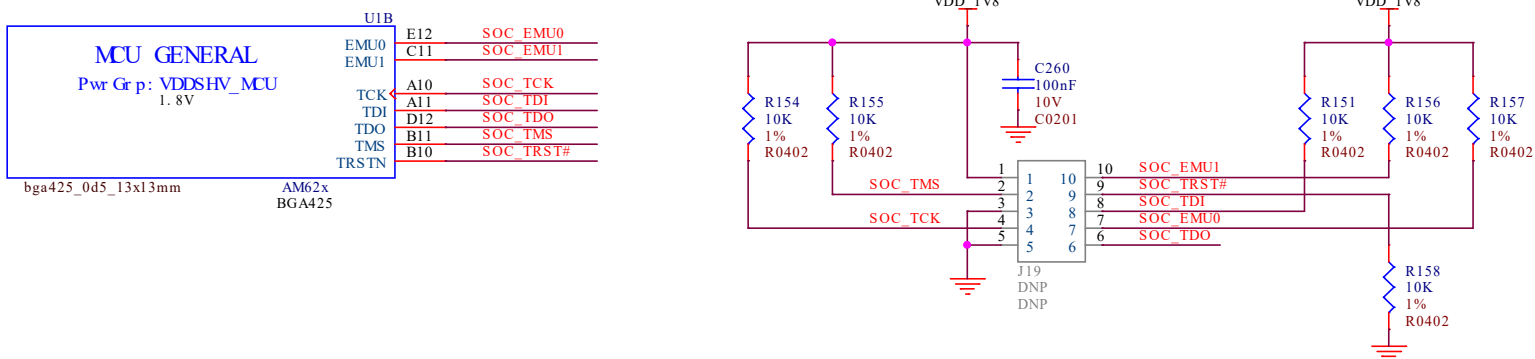

Fig. 28 AM62 JTAG debug port and TagConnect interface

CC1352 JTAG & TagConnect

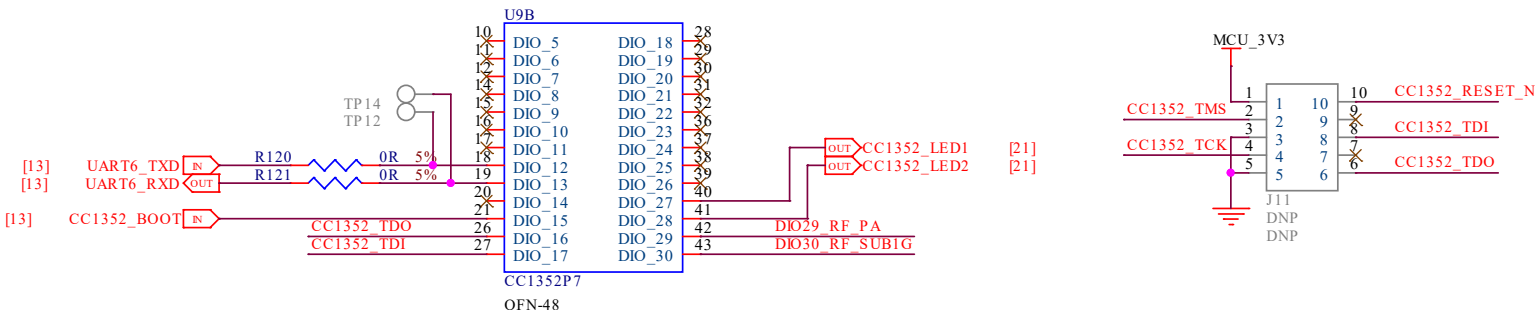

Fig. 29 CC1352 JTAG debug port and TagConnect interface

Mechanical Specifications

Dimensions & Weight

Table 5 Dimensions & weight

Parameter	Value
Size	82.5x80x20mm
Max heigh	20mm
PCB Size	80x80mm
PCB Layers	8 layers
PCB Thickness	1.6mm
RoHS compliant	Yes
Weight	55.3g

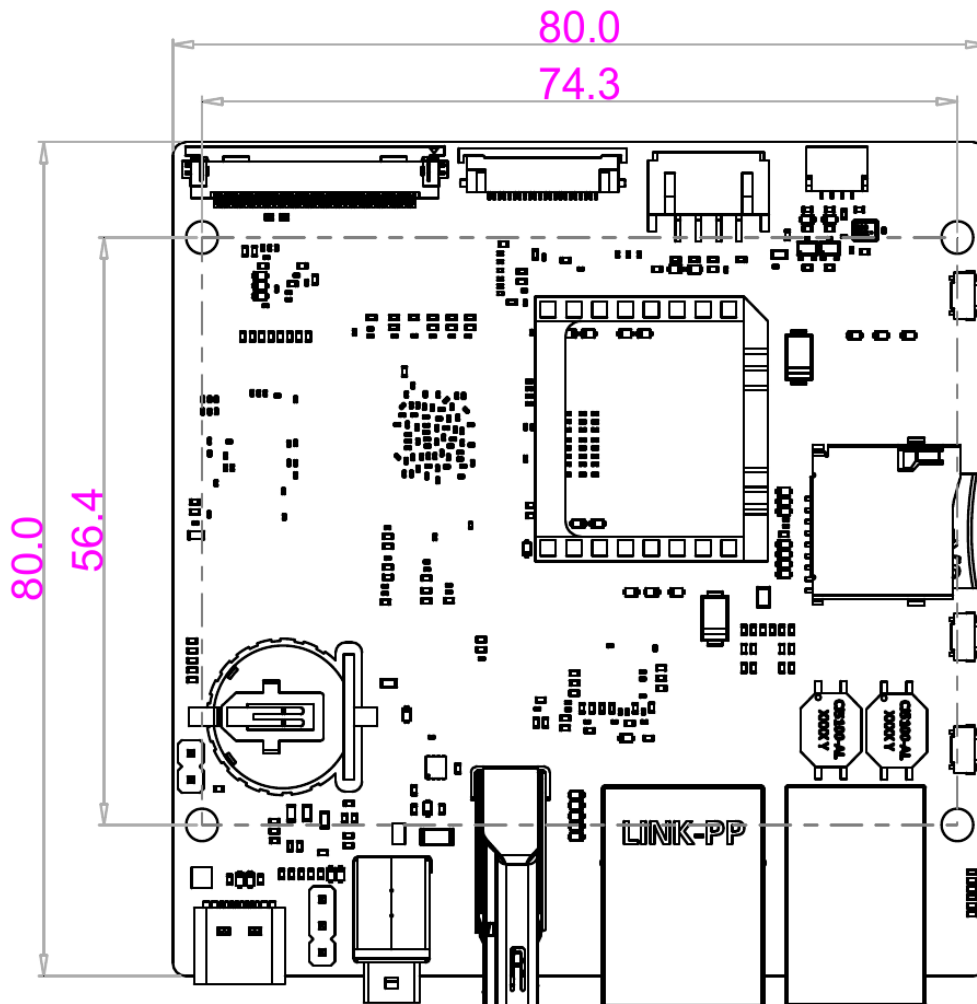

Fig. 30 *BeaglePlay* board dimensions

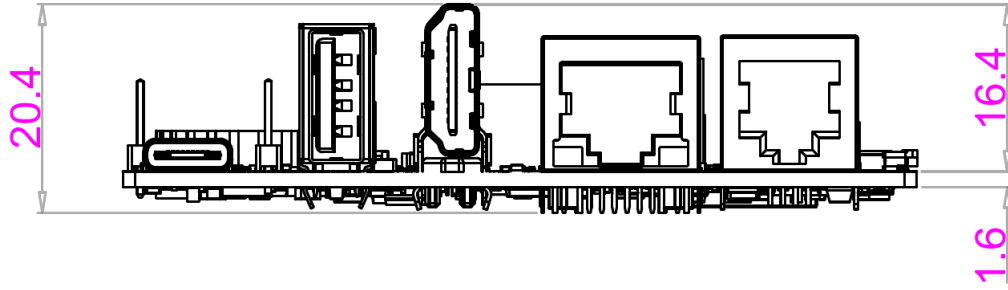

Fig. 31 *BeaglePlay board side dimensions*