



# Instructions / Directions

Training Table Keyboard Tray / Drawer  
# 5500-3-100-02



[www.kendallhoward.com](http://www.kendallhoward.com)

For details about product warranty, please visit [www.kendallhoward.com](http://www.kendallhoward.com)

**DISCLAIMER:** Kendall Howard LLC. endeavors to make this manual accurate and complete. However, Kendall Howard LLC makes no representations or warranties of any kind, expressed or implied, about whether the use of products contained herein would infringe any rights or the correctness, accuracy or reliability of the information contained herein or that said information covers all details, conditions or variations. The information herein does not provide for every possible contingency in connection with the installation or use of the product(s). The information contained in this document is subject to change without notice or obligation. Kendall Howard LLC assumes no responsibility for the accuracy, completeness or reliability of the information contained in this document. Any reliance placed on the information is therefore strictly at your own risk.

**KENDALL HOWARD** ™  
INNOVATORS IN PRODUCT DESIGN

Address: 10152 Liberty Lane  
Chisago City, Minnesota, 55013  
United States of America

Phone: 651-213-1333  
Fax: 800-418-6897

## Tools Needed:



Screw Driver

## Included:



(2) Bracket/Slides

## Assembly - Step 1:

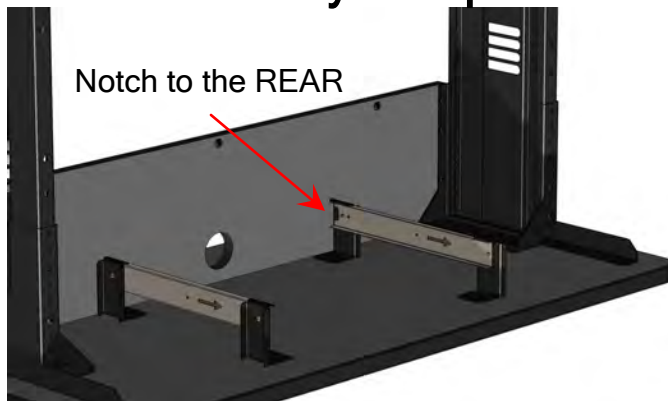

- Line up keyboard tray brackets/slides with the pre-drilled holes in the table top surface
- Make sure the notch in the slide rails is facing the rear of the table

2

## Assembly - Step 2:

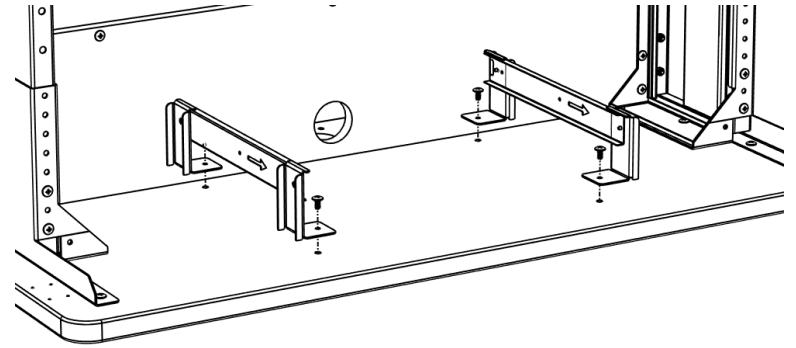

- Secure with included 1/4" screws

## Assembly - Step 3:

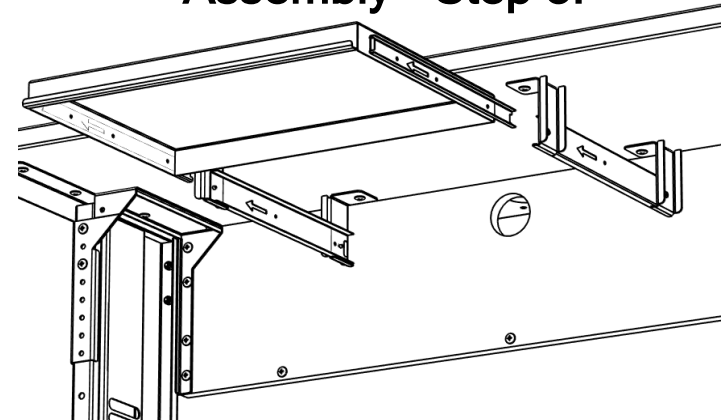

- Insert Keyboard Tray into mounted slides.
  - To utilize as a Keyboard Tray insert with hollow area facing down
  - To utilize as a Pencil Drawer insert with hollow area facing up

3