

# KENDALL HOWARD ®

## Performance Series® LAN Station / Workbench Instructions

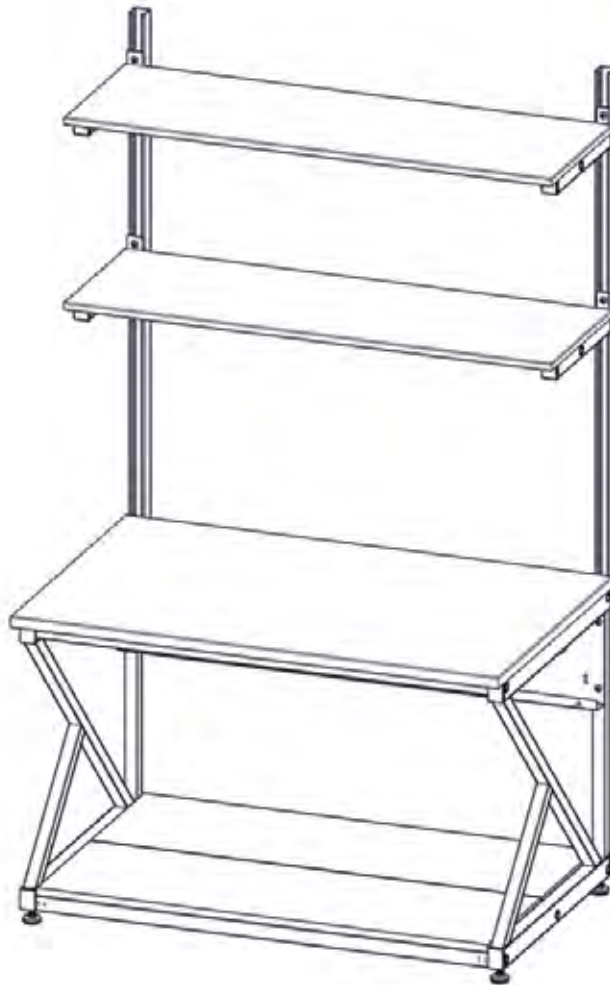

Address: 10152 Liberty Lane  
Chisago City, MN 55013  
Phone: 651-213-1333  
Fax: 800-418-6897

[www.kendallhoward.com](http://www.kendallhoward.com)



# KENDALL HOWARD

Welcome to your new Kendall Howard Performance Series® LAN Station / Workbench. Here is a little information to get you started on assembling your LAN Station / Workbench.

This instruction manual goes over the complete assembly of all four of the standard configurations. Please pay close attention to the series that you have purchased and follow along making sure you follow the steps that only pertain to your series. If you need to identify which series you have purchased, please reference the chart below by matching it with the SKU / Part Number listed on the crate.

As always, if you have any questions or concerns please reach out to us in any of the following ways:

EMAIL: [sales@kendallhoward.com](mailto:sales@kendallhoward.com)

PHONE: 651-213-1333

LIVE CHAT: Click on the blue button on the left hand of our website ([www.kendallhoward.com](http://www.kendallhoward.com)).



**100 Series**

Half Bottom Shelf & Two Upper Shelves



**200 Series**

Full Bottom Shelf & Two Upper Shelves



**300 Series**

Full Bottom Shelf & No Upper Shelves



**400 Series**

Half Bottom Shelf & No Upper Shelves

SKU / Part Number	Series Number
5000-3-100-24	100 Series
5000-3-100-48	100 Series
5000-3-100-72	100 Series
5000-3-100-96	100 Series
5000-3-101-24	100 Series
5000-3-101-48	100 Series
5000-3-101-72	100 Series
5000-3-101-96	100 Series
5000-3-102-24	100 Series
5000-3-102-48	100 Series
5000-3-102-72	100 Series
5000-3-102-96	100 Series
5000-3-103-24	100 Series
5000-3-103-48	100 Series
5000-3-103-72	100 Series
5000-3-103-96	100 Series
5000-3-104-24	100 Series
5000-3-104-48	100 Series
5000-3-104-72	100 Series
5000-3-104-96	100 Series

SKU / Part Number	Series Number
5000-3-200-24	200 Series
5000-3-200-48	200 Series
5000-3-200-72	200 Series
5000-3-200-96	200 Series
5000-3-201-24	200 Series
5000-3-201-48	200 Series
5000-3-201-72	200 Series
5000-3-201-96	200 Series
5000-3-202-24	200 Series
5000-3-202-48	200 Series
5000-3-202-72	200 Series
5000-3-202-96	200 Series
5000-3-203-24	200 Series
5000-3-203-48	200 Series
5000-3-203-72	200 Series
5000-3-203-96	200 Series
5000-3-204-24	200 Series
5000-3-204-48	200 Series
5000-3-204-72	200 Series
5000-3-204-96	200 Series

SKU / Part Number	Series Number
5000-3-300-24	300 Series
5000-3-300-48	300 Series
5000-3-300-72	300 Series
5000-3-300-96	300 Series
5000-3-301-24	300 Series
5000-3-301-48	300 Series
5000-3-301-72	300 Series
5000-3-301-96	300 Series
5000-3-302-24	300 Series
5000-3-302-48	300 Series
5000-3-302-72	300 Series
5000-3-302-96	300 Series
5000-3-303-24	300 Series
5000-3-303-48	300 Series
5000-3-303-72	300 Series
5000-3-303-96	300 Series
5000-3-304-24	300 Series
5000-3-304-48	300 Series
5000-3-304-72	300 Series
5000-3-304-96	300 Series

SKU / Part Number	Series Number
5000-3-400-24	400 Series
5000-3-400-48	400 Series
5000-3-400-72	400 Series
5000-3-400-96	400 Series
5000-3-401-24	400 Series
5000-3-401-48	400 Series
5000-3-401-72	400 Series
5000-3-401-96	400 Series
5000-3-402-24	400 Series
5000-3-402-48	400 Series
5000-3-402-72	400 Series
5000-3-402-96	400 Series
5000-3-403-24	400 Series
5000-3-403-48	400 Series
5000-3-403-72	400 Series
5000-3-403-96	400 Series
5000-3-404-24	400 Series
5000-3-404-48	400 Series
5000-3-404-72	400 Series
5000-3-404-96	400 Series

# What's in the Crate?

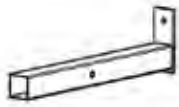

Left Upper Shelf Support

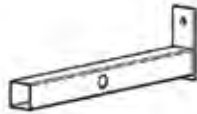

Right Upper Shelf Support

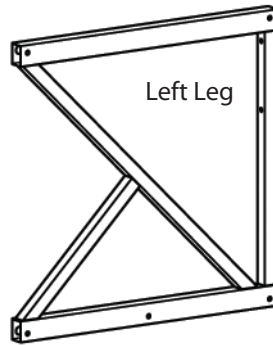

Left Leg

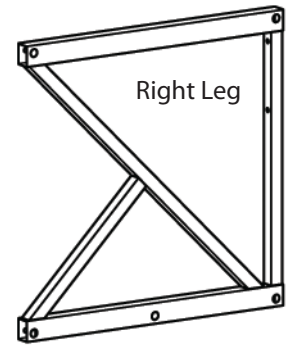

Right Leg



Cross Bar



Upper Shelf Channel  
QTY 2

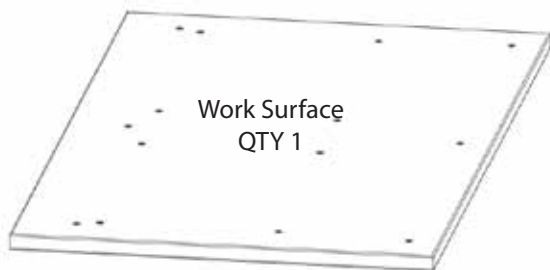

Work Surface  
QTY 1

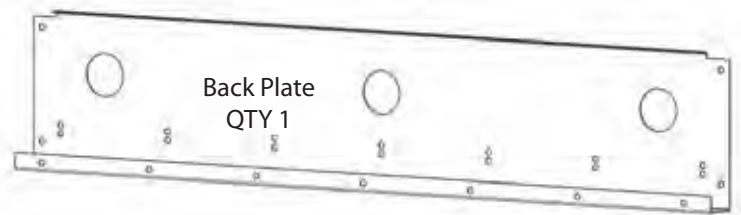

Back Plate  
QTY 1

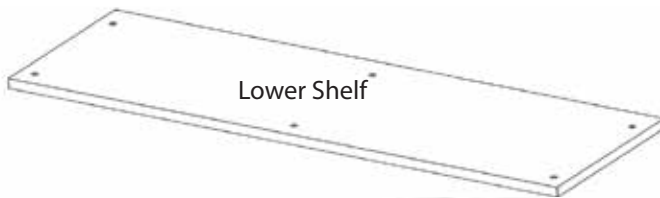

Lower Shelf

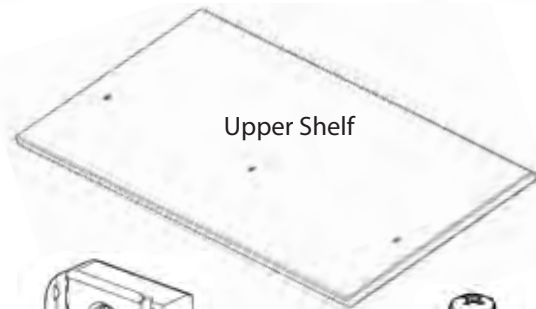

Upper Shelf



1 1/2" Bolt - Black  
QTY 18



2 1/2" Bolt - Black  
QTY 4



Channel Nut  
QTY 8



1/4-20 Cross Head Screw - Silver  
QTY 14



1 1/2" x 1 1/2" End Cap  
QTY 4

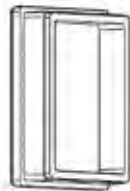

1 1/2" x 2" End Cap  
QTY 4



3/4" Round End Cap  
QTY 14



Leveler  
QTY 4

## Tools Needed:



T-Handle Hex  
Wrench  
(Included)



Phillips Head  
Screwdriver



Cordless  
Drill\*

\*If you are using a cordless drill, be sure to adjust the speed and slip so you do not cross thread or over tighten the screws.

## Step 1 - ALL SERIES

\*Please note that the number of screw locations varies by the size of the bench.  
Picture below is of a 48" bench.

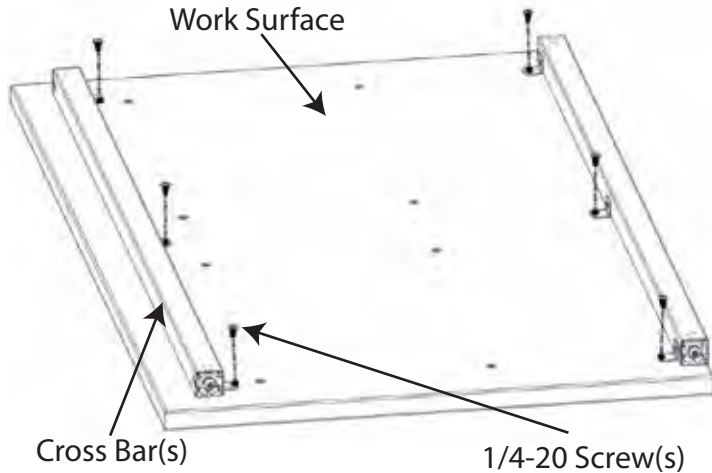

## Step 2 - ALL SERIES

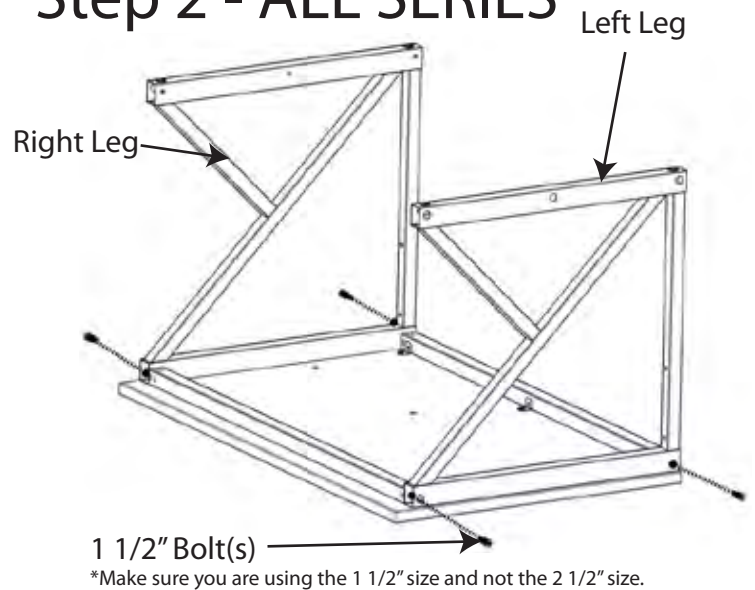

## Step 3 - ALL SERIES

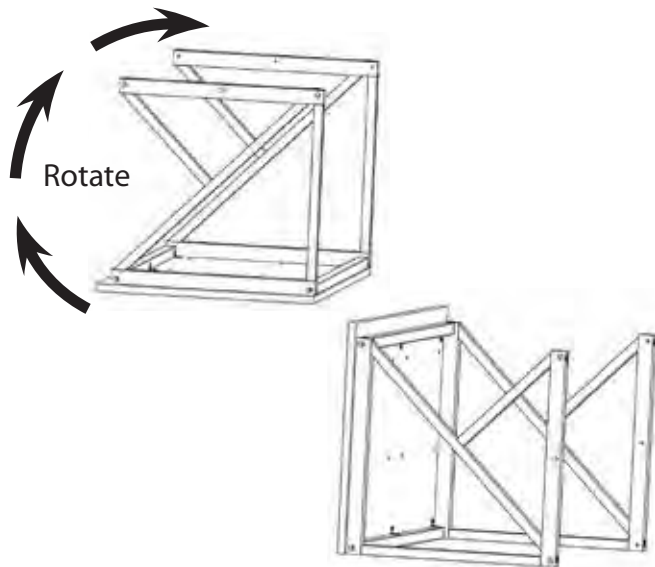

## Step 4 - 100 & 400 SERIES only have one bottom shelf. 200 & 300 SERIES have two bottom shelves.

\*Please note that the number of screw locations varies by the size of the bench.  
Picture below is of a 48" bench.

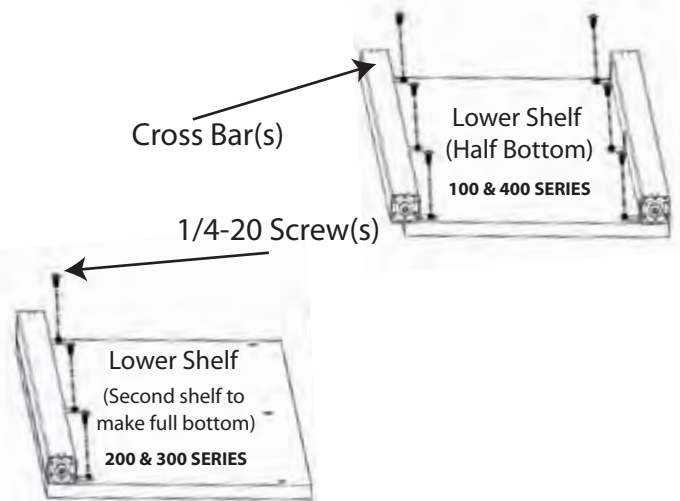

## Step 5 - ALL SERIES

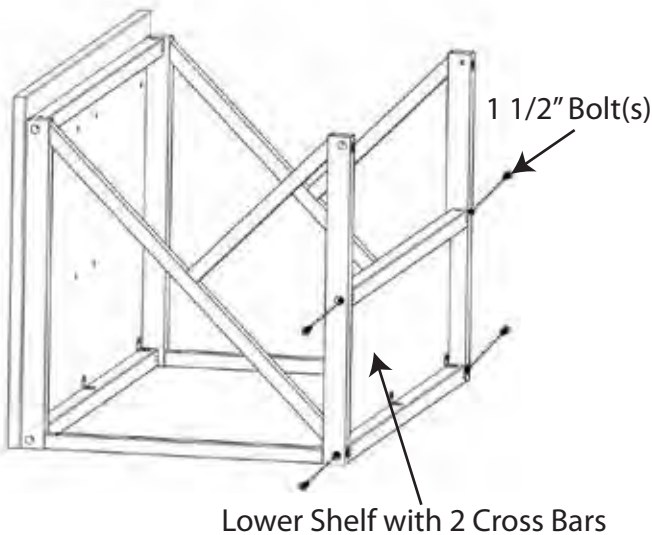

## Step 6 ONLY FOR 200 & 300 SERIES which have the full bottom shelf. 100 SERIES & 400 SERIES skip this step.

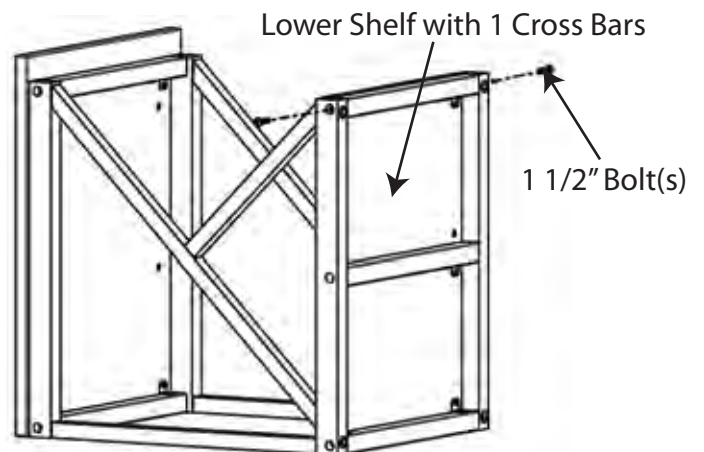

## Step 7 - ALL SERIES

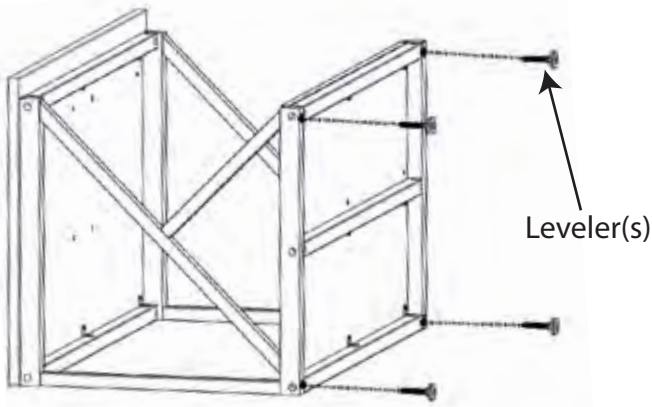

\*If you purchased the optional caster kit, install the casters instead of the levelers.

## Step 8 This completes the assembly for the 300 SERIES & 400 SERIES!

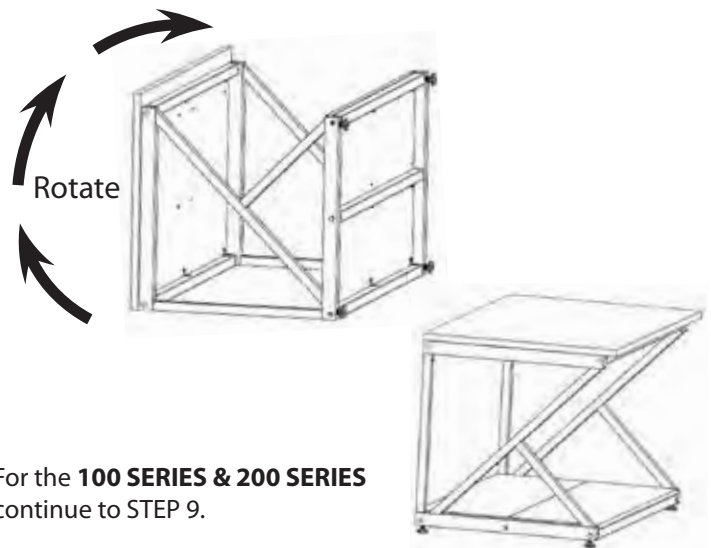

## Step 9 100 SERIES & 200 SERIES

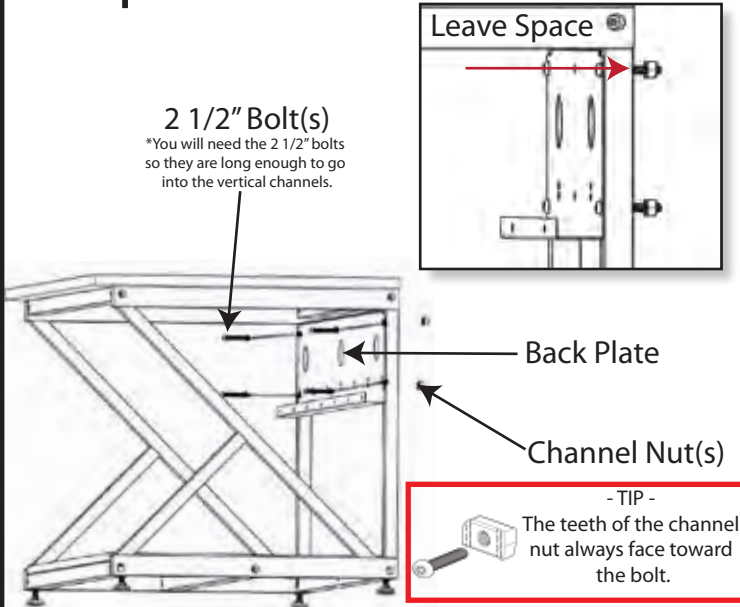

## Step 10 100 SERIES & 200 SERIES

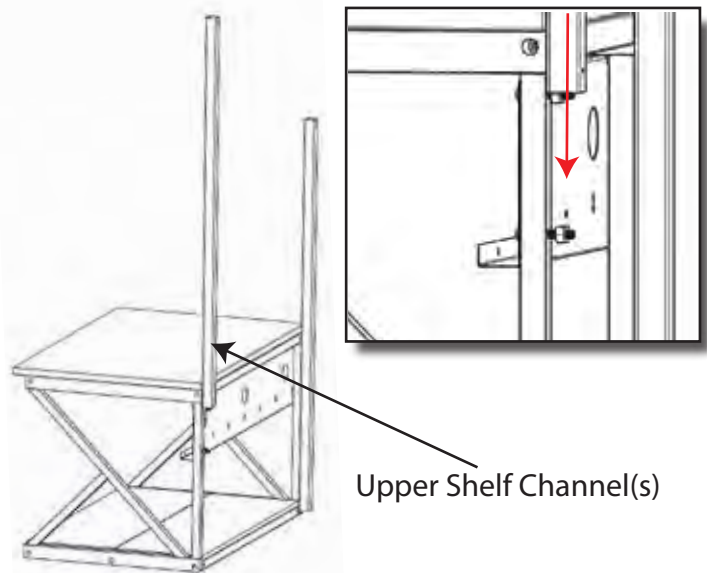

## Step 11 100 SERIES & 200 SERIES

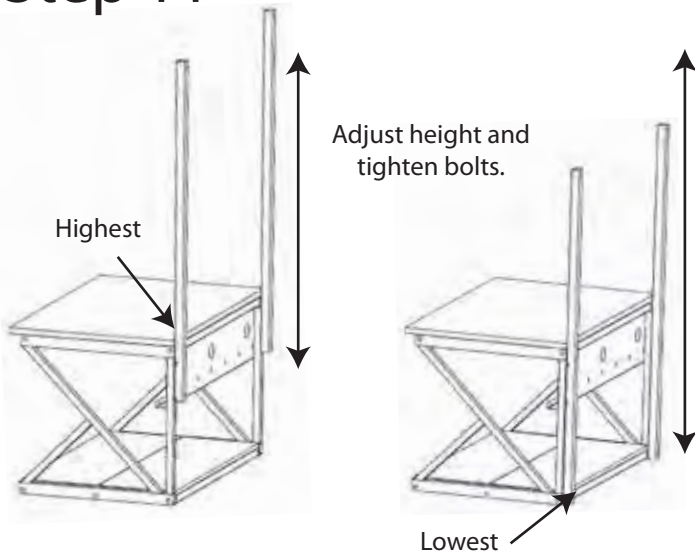

## Step 12 100 SERIES & 200 SERIES

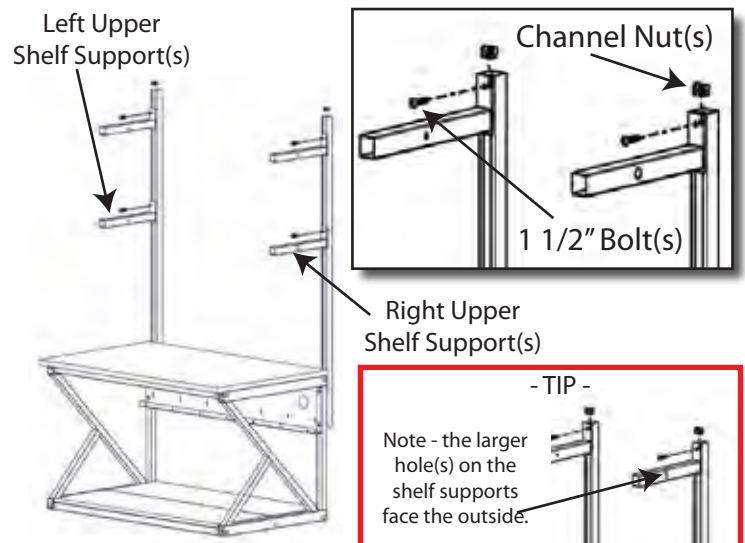

## Step 13 100 SERIES & 200 SERIES

\*Please note that the number of screw locations varies by the size of the bench.  
Picture below is of a 48" bench.

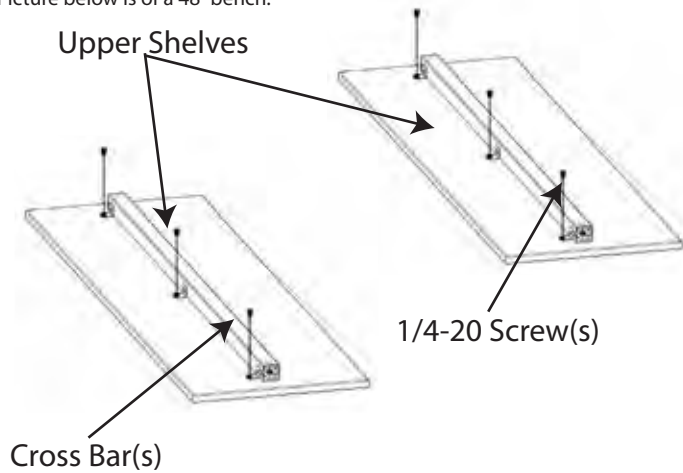

## Step 14 100 SERIES & 200 SERIES

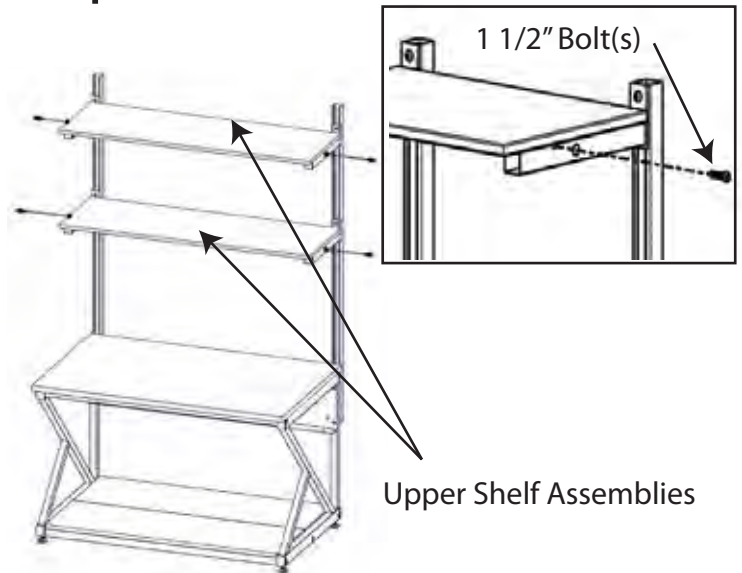

## Step 15 100 SERIES & 200 SERIES

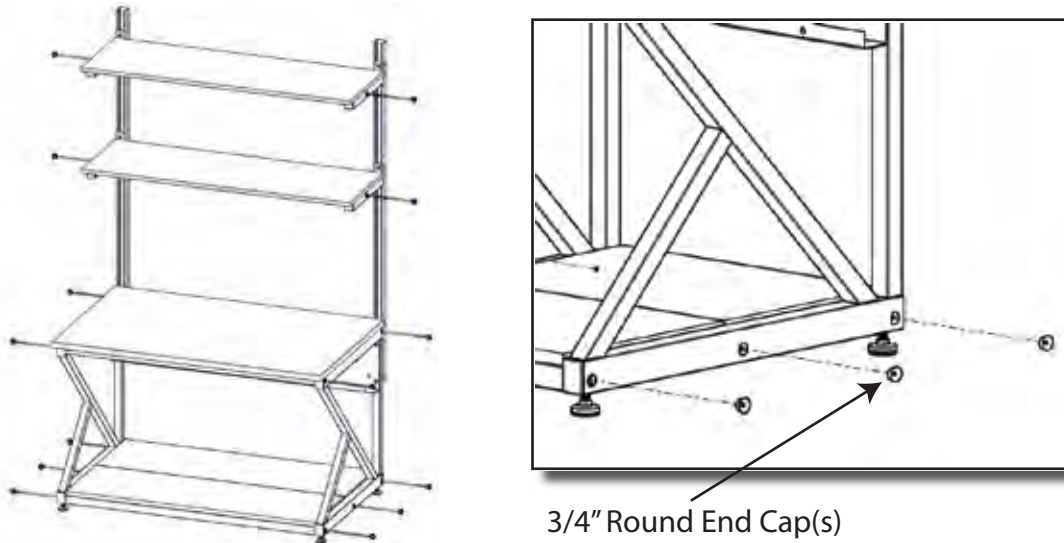

## Step 16 100 SERIES & 200 SERIES

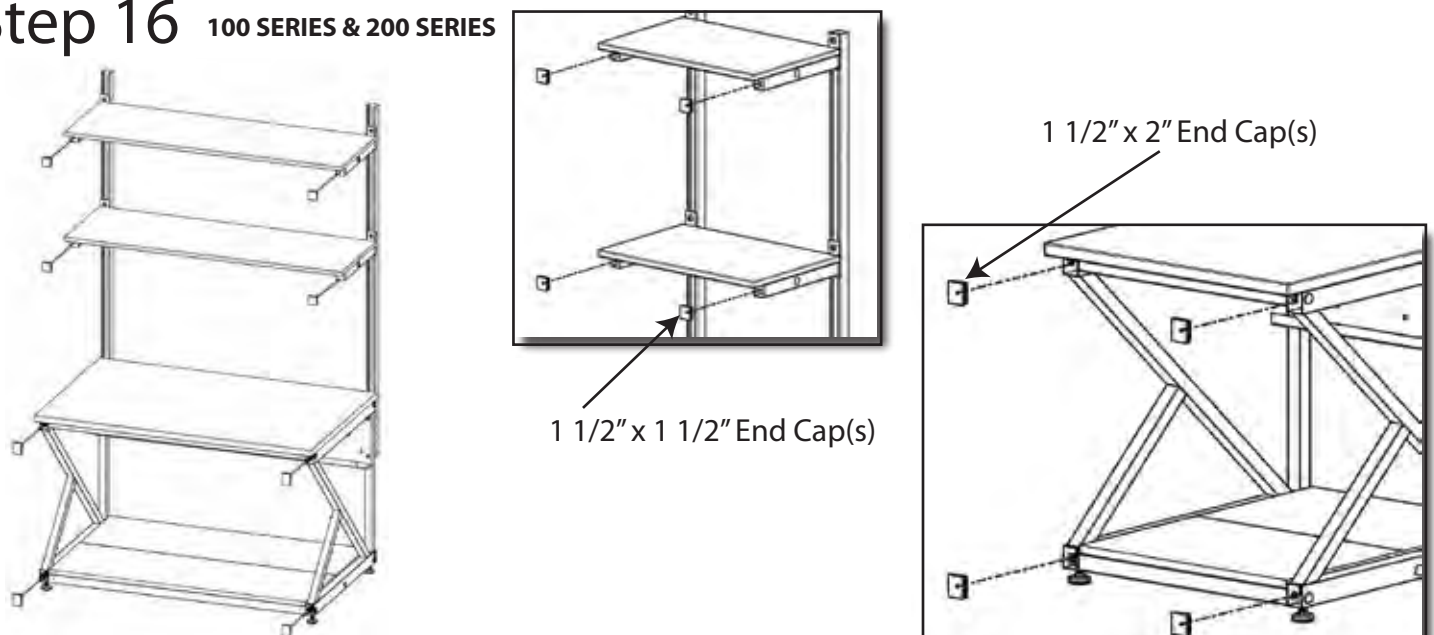



For details about product warranty, please visit [www.kendallhoward.com](http://www.kendallhoward.com)

**DISCLAIMER:** Kendall Howard LLC. endeavors to make this manual accurate and complete. However, Kendall Howard LLC makes no representations or warranties of any kind, expressed or implied, about whether the use of products contained herein would infringe any rights or the correctness, accuracy or reliability of the information contained herein or that said information covers all details, conditions or variations. The information herein does not provide for every possible contingency in connection with the installation or use of the product(s). The information contained in this document is subject to change without notice or obligation. Kendall Howard LLC assumes no responsibility for the accuracy, completeness or reliability of the information contained in this document. Any reliance placed on the information is therefore strictly at your own risk.