

XMT® 650 ArcReach® Systems

Multiprocess Welding System 

Quick Specs

Heavy Industrial Applications

Fabrication and construction
Structural steel fabrication/erection
Heavy manufacturing
MRO — maintenance/repair
Pressure tank/vessel fabrication
Shipbuilding
Refineries and foundries
Railcar manufacturing
Earth-moving equipment manufacturing

Processes

MIG (GMAW)
Flux-cored (FCAW)
Stick (SMAW)
DC TIG (GTAW)*
Submerged arc (SAW)*
Air carbon arc (CAC-A) cutting and gouging
Rated: 3/8-inch carbons
Induction heating**

Input Power 460 V, 60 Hz, 3-phase power

Output Range 10–815 A, 10–65 V

Rated Output 650 A at 44 VDC, 100% duty cycle

Net Weight 187 lb. (84.8 kg)

ArcReach Remote voltage control without a control cord

**Not available with Polarity Reversing model.*

***Available with ArcReach Heater only.*



Game-changing welding technologies can stop you from wasting hours every day.

ArcReach welding technology minimizes the non-value-added time spent walking to and from the power source — and maximizes arc-on time, weld quality and jobsite safety.

When operators have complete control at the feeder or remote — even hundreds of feet away from the power source — it minimizes downtime and maximizes productivity, while improving operator safety and delivering high quality welds.



Next Level Productivity



Next Level Cost Savings



Next Level Power



XMT 650 ArcReach with Polarity Reversing power source shown with ArcReach 16 field roller wire feeder.

ArcReach®

Remote voltage control at the wire feeder or remote without a control cord. See page 2 for more information.

XMT 650 ArcReach system is ideal for:

- Structural steel fabrication
- General construction
- Shipbuilding

XMT 650 ArcReach with Polarity Reversing system is ideal for:

- Structural steel erection



Power source is warranted for three years, parts and labor.



Miller Electric Mfg. LLC

An ITW Welding Company
1635 West Spencer Street
P.O. Box 1079
Appleton, WI 54912-1079 USA

Equipment Sales US and Canada

Phone: 866-931-9730
FAX: 800-637-2315
International Phone: 920-735-4554
International FAX: 920-735-4125

MillerWelds.com



XMT® 650 ArcReach® Systems Benefits



Next Level Productivity

ArcReach® capabilities eliminate the time spent tracing weld cables hundreds of feet back to the power source because weld operators can make adjustments at the ArcReach wire feeder or remote.

- **Cable Length Compensation (CLC™)** ensures that the voltage a weld operator sets is the voltage they get by automatically adjusting voltage based on weld cable length, even hundreds of feet away from the power source.
- **Process selection at point of use** to easily switch between welding and gouging with ArcReach 16 wire feeder.
- **Return to a previous weld process faster** because the power source is restored to its previous settings once the ArcReach accessory is removed.
- **Decrease the chance of an incorrect weld process used** because Auto-Process Select™ automatically sets the power source to the correct weld process based on the polarity applied to the weld accessory.
- **Shop cart** option with caster wheels and handle makes it easy to transport the wire feeder across the shop and under I-beams.
- **Field roller** is equipped with rollers to make it easier than ever to pull the ArcReach 16 wire feeder across pan decking.



Next Level Cost Savings

Maximize savings by simplifying your fleet and accessories, being ready-to-weld with preassembled wire feeders, eliminating inefficiencies, and minimizing equipment downtime with XMT 650 ArcReach systems.

- **Eliminate the control cable** and reduce inventory and maintenance expense with ArcReach.
- **Eliminate dedicated gouging power sources** with integrated gouging stud at the wire feeder.
- **Eliminate cart/sled custom design and assembly** and be ready-to-weld in minutes with a preassembled ArcReach 16 wire feeder.
- **Enable welder with full control at point of use**, increasing efficiency.
- **Adjust While Welding (AWW™)** allows weld operators to change weld parameters while the arc is on.
- **Rugged and durable** means equipment lasts — with IP23 rating, Wind Tunnel Technology™ and Fan-On-Demand™.



Next Level Power

Power for all your welding and gouging needs.

- **Field-proven gouge process.** Remove more material per pass with optimized gouge process without sacrificing control.
- **Weld power to meet productivity needs.** Improve your project timelines with the ability to use large diameter filler wires and minimize downtime with large spools.
- **Elevated arc performance across jobs.** Provides the ability to run a vast range of wire diameters with ideal power. Enables flexibility without sacrificing performance.
- **Rack option** houses four XMT 650 power sources in one convenient package for multiple operators.

ArcReach®

Remote control of the power source without a cord.

ArcReach technology uses the existing weld cable to communicate welding control information between the feeder or remote and power source. This technology eliminates the need for control cords, and their associated problems and costs.

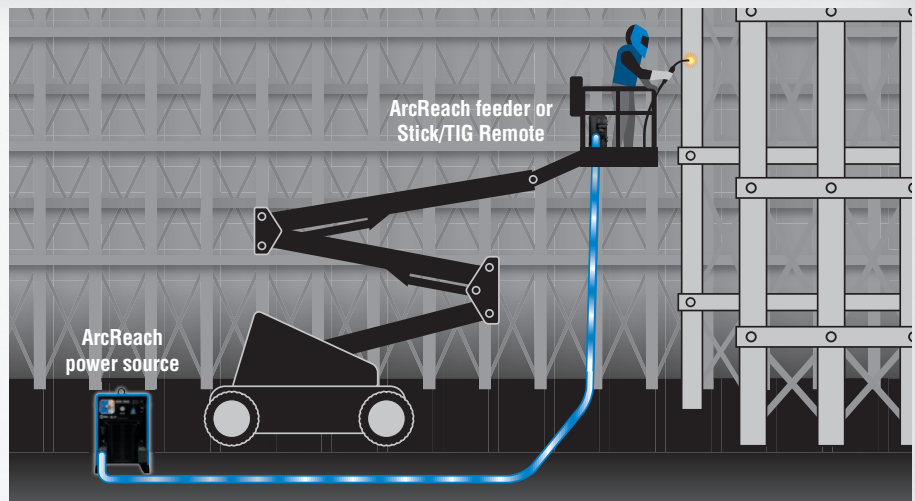

XMT® 650 ArcReach® Features



Remote in use indicator provides convenient feedback indicating an ArcReach® wire feeder is controlling the power source. While under ArcReach control, process and voltage/ amperage adjustments are locked out, preventing accidental changes by personnel other than the welding operator.

Auto Remote Sense™ enables unit to automatically use remote control if connected to remote control receptacle.

14-pin receptacle has the flexibility to be used with spool guns, feeders, and remote controls.

Arc control is active in the stick and solid-wire processes. It allows the operator to customize arc characteristics to match preference, electrode and joint design from a softer arc with more fluid puddle to a stiffer arc with a more controllable puddle. The Star setting is optimized for most applications and pointing the control at Soft or Stiff is optimal for most arc preferences. Control is fully adjustable from 0 to 25 Soft or 0 to 25 Stiff.



Back panel. 20 amps of 120-volt power to run power tools — like grinders, chop saws, drills and lights.



LED process indicator. Front panel process selections are illuminated with an LED that identifies the active process. This enables the selected weld process to be seen at a distance from the power source.

- Gouging mode is an optimized stick position for better gouging performance
- Three wire modes (GMAW/FCAW/SAW) for simplified setup and optimized arc performance
 - Solid and flux-cored wires with gas
 - Flux-cored (self-shielded)
 - Sub arc
- Stick mode for all electrode types
- Lift-Arc™ TIG

XMT 650 ArcReach with Polarity Reversing Features

Easy to use. The XMT 650 ArcReach with Polarity Reversing power source is streamlined and simplified to reduce setup time and potential weld defects. Process changeover eliminates the need for swapping cables. The robust design withstands harsh environments common in the field.

Auto Remote Sense™ enables unit to automatically use remote control if connected to remote control receptacle.

14-pin receptacle for remote controls.

Arc control is active in the stick and solid-wire processes. It allows the operator to customize arc characteristics to match preference, electrode and joint design from a softer arc with more fluid puddle to a stiffer arc with a more controllable puddle. The Star setting is optimized for most applications and pointing the control at Soft or Stiff is optimal for most arc preferences. Control is fully adjustable from 0 to 25 Soft or 0 to 25 Stiff.



LED process indicator. Front panel process selections are illuminated with an LED that identifies the active process. This enables the selected weld process to be seen at a distance from the power source.

- Gouging mode is an optimized stick position for better gouging performance
- Two wire modes (GMAW/FCAW) for simplified setup and optimized arc performance
 - Solid and flux-cored wires with gas
 - Flux-cored (self-shielded)

ArcReach® 16 Features

Set volts, wire feed speed and process remotely. The simple interface allows operators to adjust parameters at the point of use with no control cords.



Setting the standard for performance. Heavy-duty drive motor with tachometer control provides wire feed speed

that is accurate and consistent from the start of the weld to the finish and from one weld to the next, providing consistent arc quality. Wide voltage range for small and large wires with no contactor chatter or arc outages.

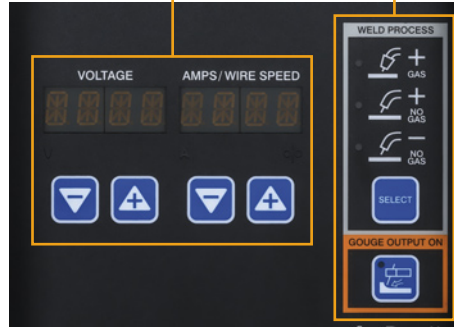

Durable design reduces downtime. The elimination of feeder control cords and field assembly IP23 rating provides a solid solution to last in harsh environments.

Easy process changeover. Simply connect the ArcReach 16 wire feeder to your weld lead and you are ready to go. Switch between welding and gouging with a push of a button with no need to swap leads or disconnect the wire feeder with isolated outputs.

Weld with up to 60-pound spools and large diameter (3/32 in.) wire to minimize downtime and maximize productivity.

Integrated gouging stud on wire feeder. Isolated gouging stud allows easy connection for gouging at point of use, eliminating the need to disconnect the wire feeder and to swap leads.

ArcReach 16 options

Easy mobility in the shop and on-site. The ArcReach 16 wire feeder preassembled options include a shop cart and a field roller for your mobility needs.



Bench feeder



Preassembled shop cart provides easy shop mobility with low clearance. Handle doubles as a cable holder.



Preassembled field roller provides easy field mobility over pan decking and other surfaces. Designed for the environment with spool cover and IP23 rating. Includes spool cover, hanging bail and cable holder.

Bernard® IronPro™ 450-15 Self-Shielded FCAW Gun



Gun designed for structural steel erector sites with 15-foot (4.6 m) cable and short handle for excellent joint access and maneuverability. Rated at 450 amps at 60 percent duty cycle with 3/32-inch (2.4 mm) liner for large diameter FCAW wires. Includes AccuLock™ consumables.

- Extended life with sealed trigger that remains slag and spatter free, gasless tip insulation and replaceable neck
- Ergonomic design provides excellent access and maneuverability for hard-to-reach weld joints
- Durable gun ideal for outdoor environments

Insulators	NS-AFLX	Gasless tip insulation — AccuLock
Neck	1370270	Gasless, 12 in. long, 30° bend, "Q" neck assembly, AccuLock
	1370271	Gasless, 7 in. long, 60° bend, "Q" neck assembly, AccuLock
Liner	L7A-15	For 3/32 in. (2.4 mm)
Jump Liner	QJL-L7	Gasless, 3/32 in. (2.4 mm)
Tips	T-A078CH	5/64 in. (2.0 mm)
	T-A094CH	3/32 in. (2.4 mm)
Heat Shield	1760013	"Q" neck adapter, one-piece heat shield

XMT® 650 ArcReach® Specifications (Subject to change without notice.)



Amperage/Voltage Ranges	Rated Output	Amps Input at Rated Output, 60 Hz			Max. Open-Circuit Voltage	Dimensions	Net Weight
		460 V	KVA	KW			
10–815 A in CC mode	650 A at 44 VDC, 100% duty cycle	42.6	33.9	31.9	82	H: 28.187 in. (716 mm) (including lift eye) W: 16.687 in. (424 mm) D: 31.625 in. (803 mm)	187 lb. (84.8 kg)
10–44 V in CV mode	750 A at 44 VDC, 60% duty cycle	49.1	39.1	37.2			
10–65 V in SAW model*	825 A at 44 VDC, 25% duty cycle	53.6	42.7	40.5			

*Not available with Polarity Reversing model.

Certified by Canadian Standards Association to both the Canadian and U.S. Standards.

ArcReach® 16 Specifications (Subject to change without notice.)

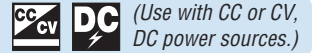

Input Power	Input Welding Circuit Rating	Wire Feed Speed	Wire Type and Diameter Capacity	Max. Spool Size Capacity	Dimensions (H x W x D)	Net Weight
Operates on open-circuit voltage and arc voltage: 12–110 VDC	450 A at 100% duty cycle	50–780 ipm (1.3–19.8 m/min.) dependent on arc voltage	Solid wire .035–5/64 in. (0.9–1.9 mm)	18 in. (457 mm) 60 lb. (27.2 kg)	Base feeder 15.3 x 16.7 x 32.8 in. (388 x 424 x 833 mm)	Base feeder 101 lb. (45.8 kg)
	500 A at 60% duty cycle					
	CAC-A 600 A at 40% duty cycle				Field roller 28.2 x 19.9 x 42.7 in. (716 x 505 x 1,084 mm)	Field roller 123 lb. (55.7 kg)

Performance Data

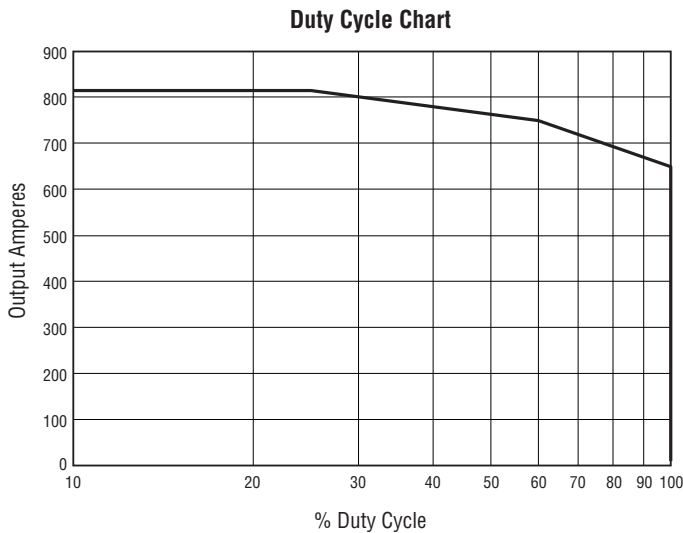

Mounting Specifications

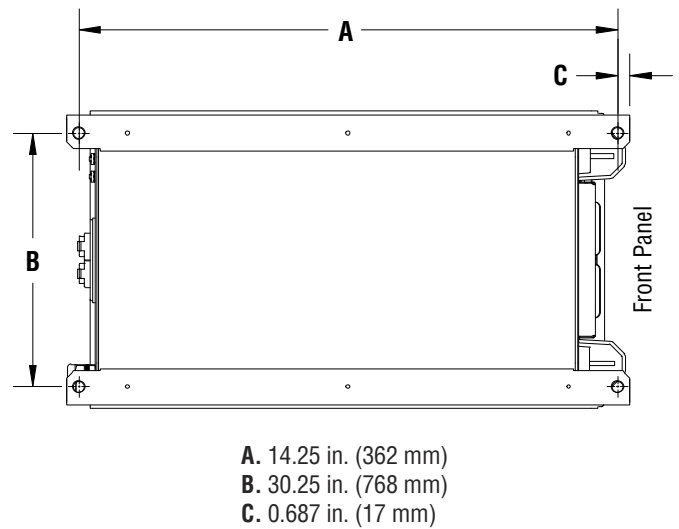

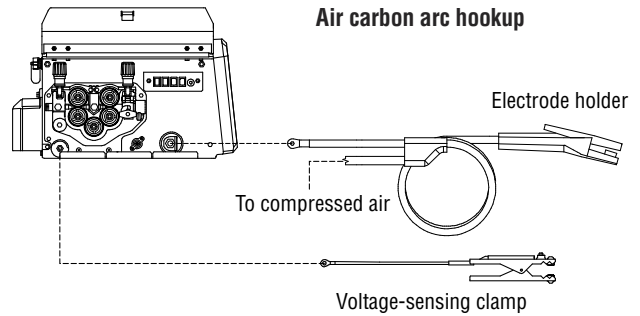
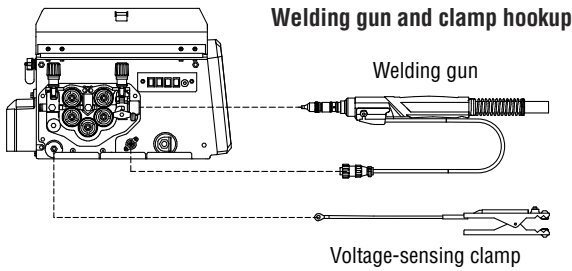
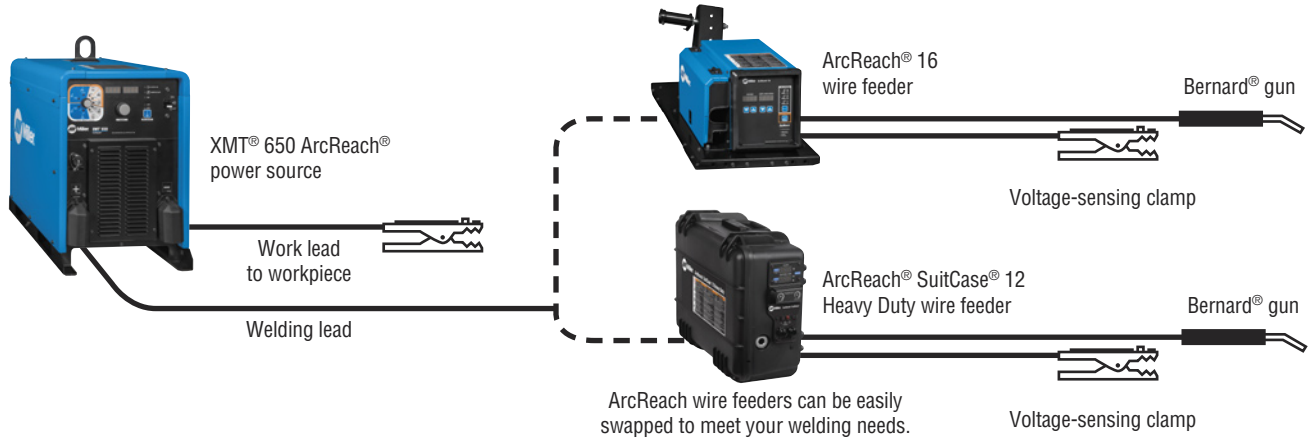

Typical Installation and Hookups

MIG/FCAW installation diagram



ArcReach® 16 Drive Roll Kits and Guides

Select drive roll kits from chart below according to type and wire size being used. Drive roll kits include four drive rolls, necessary guides and feature an anti-wear sleeve for inlet guide.

Wire Size	V-groove for hard wire 	V-knurled for hard-shelled cored wires 	U-cogged for extremely soft wire or soft-shelled cored wires (i.e., hard facing types) 
.035 in. (0.9 mm)	151026	151052	—
.035 and .045 in. (0.9 and 1.2 mm)	235336*	151052	—
.040 in. (1.0 mm)	161190	—	—
.045 in. (1.1/1.2 mm)	151027	151053	151070
.052 in. (1.3/1.4 mm)	151028	151054	—
1/16 in. (1.6 mm)	151029	151055	151072
.068/.072 in. (1.8 mm)	—	151056	—
5/64 in. (2.0 mm)	—	151057	—
3/32 in. (2.4 mm)	—	151058	—

Wire Guides

Wire Size	Inlet Guide	Intermediate Guide
.023–.040 in. (0.6–1.0 mm)	221030	056206
.045–.052 in. (1.2–1.3 mm)	221030	056207
1/16–5/64 in. (1.6–2.0 mm)	221030	056209
5/64–1/8 in. (2.0–3.2 mm)	229919	056211

*Drive roll is dual-size reversible with one .035-inch and one .045-inch groove.

Genuine Miller® Accessories



XMT® 650 ArcReach® 4-Pack Racks
Coming Soon Without polarity reversing
Coming Soon With polarity reversing
 Comes assembled with four XMT 650 ArcReach power sources fused for 460 volts. Features include:

- Provision to parallel power sources on common work connections
- Two lifting eyes for transportation
- Rugged skids for dragging or pushing



ArcReach® SuitCase® 12 Heavy Duty 301604
 Feeder only — for 3/32-inch cored wire. Portable feeder designed to run off of arc voltage. When paired with an ArcReach power source, provides remote control of

the power source without a control cord — saving time and money. See literature M/6.55.



Running Gear Cylinder Rack 300408
 Small footprint and easily maneuverable, with cylinder rack low enough that you do not have to lift bottles.



ArcReach® Stick/TIG Remote 301325
 When paired with an ArcReach power source, provides remote control of the power source

without a cord — saving time and money. See literature AY/14.5.



Industrial MIG 4/0 Kit 300390
 Consists of flowmeter regulator with 10-foot (3 m) gas hose, 10-foot (3 m) 4/0 feeder weld cable with lugs, and 15-foot (4.6 m) work cable with 600-amp C-clamp.



Wire Reel Assembly 108008
 For 60-pound (27 kg) coil of wire.

ArcReach® Heater System



ArcReach Heater Packages
951848 ArcReach Heater CSA model and extension cable
951849 ArcReach Heater CSA model, extension cable and two air-cooled quick wraps

ArcReach Heater Only
301390 CSA model
301591 CE model
 The ArcReach Heater is equipped with built-in temperature control allowing for either manual or computer-loaded programming using up to six thermocouples. The ArcReach Heater can run either one or two heating tools (air-cooled cable or air-cooled quick wrap) simultaneously. Requires ArcReach Heater extension cable to operate. See literature IN/16.0.
Note: Weld cables are not included.



ArcReach Heater Extension Cable 301451 10 ft. (3 m)
 Air-cooled cables or quick wraps connect to the side of the box. Up to six thermocouple sensors connect to the yellow panel, and provide temperature feedback from the piece being heated.



Air-Cooled Quick Wrap 301452
 The quick wrap works on pipe up to 10-inch (25.4 cm) diameter, and can heat up to a maximum of 600 degrees Fahrenheit (315°C). Requires preheat insulation for temperatures over 392 degrees Fahrenheit (200°C) to protect the tool. Most joints will require simultaneous use of two-air cooled quick wraps — one on each side of the joint.



Preheat Insulation with Cable Harness 301334 1/2 x 16 x 120 in. (1.3 x 41 x 305 cm)
 Air-cooled heating cable coils of various sizes can be attached directly to this preheat insulation. Once a coil is set up it can easily be moved from part to part reducing setup times. The insulation is 10-foot (3 m) long and can be cut to length to fit your application.
Note: Heating cable not included.

High-Temperature Rope 194965
 1-inch (2.5 cm) wide, 50-foot (15.2 m) roll.

Ordering Information

Power Source and Options	Stock No.	Description	Qty.	Price
XMT® 650 ArcReach®	907823	460 V, 60 Hz		
XMT® 650 ArcReach® with Polarity Reversing	Coming Soon	460 V, 60 Hz		
XMT® 650 ArcReach® 4-Pack Rack	Coming Soon	Fused for 460 V, 60 Hz		
XMT® 650 ArcReach® with Polarity Reversing 4-Pack Rack	Coming Soon	Fused for 460 V, 60 Hz		
Wire Feeders				
ArcReach® 16	301619 301664 Coming Soon Coming Soon Coming Soon	Base feeder only With shop cart With shop cart and Bernard® BTB Gun 400 A with AccuLock™ consumables With integrated field rollers, spool cover, hanging bail and cable holder With field roller and Bernard® IronPro™ 450-15 gun with AccuLock™ consumables		
ArcReach® SuitCase® 12 Heavy Duty	301604	Tweco-style connectors, feeder only, for 3/32 in. flux-cored wire		
Guns				
Bernard® BTB Gun 400 A (GMAW)		See Bernard literature SP-BTB		
Bernard® IronPro™ 450-15 (FCAW)	Coming Soon	15 ft. (4.6 m), AccuLock™ consumables, configured for 3/32 in. wire		
Bernard® Dura-Flux™ (FCAW)		See Bernard literature SP-DF		
Accessories				
Running Gear Cylinder Rack	300408			
ArcReach® Stick/TIG Remote	301325	Point-of-use control for stick or TIG welding and gouging		
Industrial MIG 4/0 Kit	300390	Includes flowmeter regulator with 10 ft. (3 m) gas hose, 10 ft. (3 m) 4/0 feeder weld cable with lugs, and 15 ft. (4.6 m) work cable with 600-amp C-clamp		
Wire Reel Assembly	108008	For 60 lb. coils		
Inline Filter	211989			
ArcReach® Heater System				
ArcReach Heater Packages	951848 951849	Includes ArcReach Heater and extension cable Includes ArcReach Heater, extension cable and two air-cooled quick wraps		
ArcReach Heater Only	301390 301591	Requires extension cable to operate. Included in packages above, CSA Requires extension cable to operate. Not available as a package, CE		
ArcReach Heater Extension Cable Only	301451	10 ft. (3 m)		
Air-Cooled Quick Wrap <i>Requires preheat insulation for temperatures over 392°F (200°C).</i>	301452	For up to 10 in. (25.4 cm) diameter pipes		
Preheat Insulation with Cable Harness	301334	1/2 x 16 x 120 in. (1.3 x 41 x 305 cm)		
High-Temperature Rope	194965	1-inch (2.5 cm) wide, 50-foot (15.2 m) roll		
ArcReach® 16 Consumables				
Drive Rolls		See page 6		
Guides		See page 6		

Date:

Total Quoted Price:

Distributed by:

