



TECHNICAL CATALOGUE

SELF-CLEANING STRAINER



ITAP SpA, founded in Lumezzane (Brescia) in 1972, is currently one of the leading production companies in Italy of valves, fittings and distribution manifolds for plumbing and heating systems. Thanks to fully automated production processes, with 72 tooling machines and 51 assembly lines, we are able to produce 200,000 pieces per day. Our innate pursuit for innovation and observance of technical regulations is supported by the company certification ISO 9001: 2008. The company has always considered its focus on quality as the main tool to obtain significant business results: today ITAP SpA is proud to offer products bearing the approval of numerous international certifying bodies.



SELF-CLEANING STRAINER



SELF-CLEANING
STRAINER

SUITABLE FOR DOMESTIC
WATER SERVICES, HEATING AND
AIR-CONDITIONING PLANTS,
COMPRESSED AIR SYSTEMS.

189

SELF-CLEANING STRAINER



SIZE	PRESSURE	CODE	PACKING
1/2" (DN 15)	16bar/232psi	1890012	1/9
3/4" (DN 20)	16bar/232psi	1890034	1/9
1" (DN 25)	16bar/232psi	1890100	1/6
1"1/4 (DN 32)	16bar/232psi	1890114	1/6
1"1/2 (DN 40)	16bar/232psi	1890112	1/5
2" (DN 50)	16bar/232psi	1890200	1/5

TECHNICAL SPECIFICATIONS

Supplied with an extractable straining cartridge, double pressure gauge and hose cock to dump the impurities.

Body in nickel-plated brass.

Minimum and maximum working temperatures:

-20°C, 110°C in absence of steam.

Filtration degree: 300µm.

Threads: ISO228

(equivalent to DIN EN ISO 228 and BS EN ISO 228).

MATERIALS

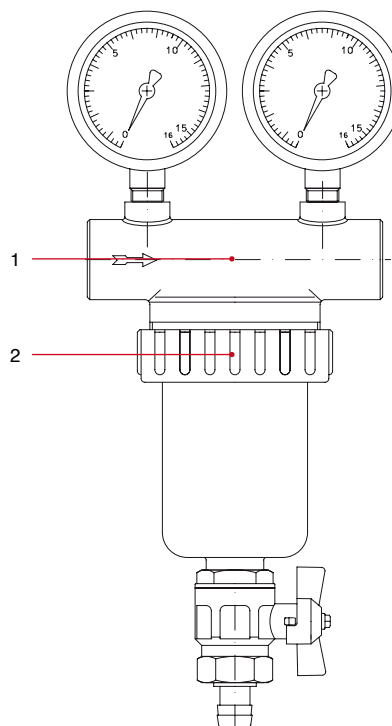

POS.	DESCRIPTION	N.	MATERIAL
1	Body	-	Nickel-plated brass CB735S
2	Nut	-	Nickel-plated brass CW617N
-	Cartridge	-	Stainless steel AISI 304
-	Cartridge seats	-	NBR
-	O-Ring	-	NBR
-	Plastic parts	-	Ultramid®



OVERALL DIMENSIONS

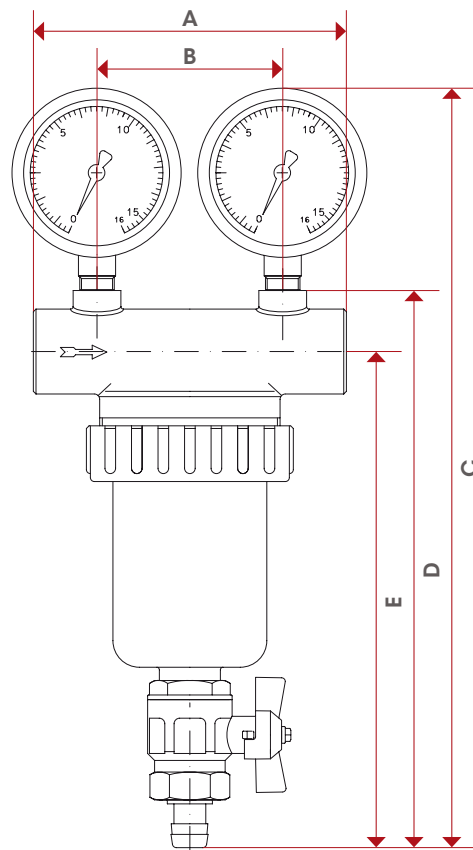

	1/2"	3/4"	1"	1 1/4"	1 1/2"	2"
A	118	118	123	123	153	153
B	70	70	72	72	98	98
C	272	272	302	302	342	342
D	208	208	234	234	272	272
E	187	187	202	202	236	236
Kg/cm ² bar	16	16	16	16	16	16
LBS - psi	232	232	232	232	232	232

CERTIFICATIONS



FLOW RATE AND PRESSURE DROP CHART

WITH WATER

Art: 189

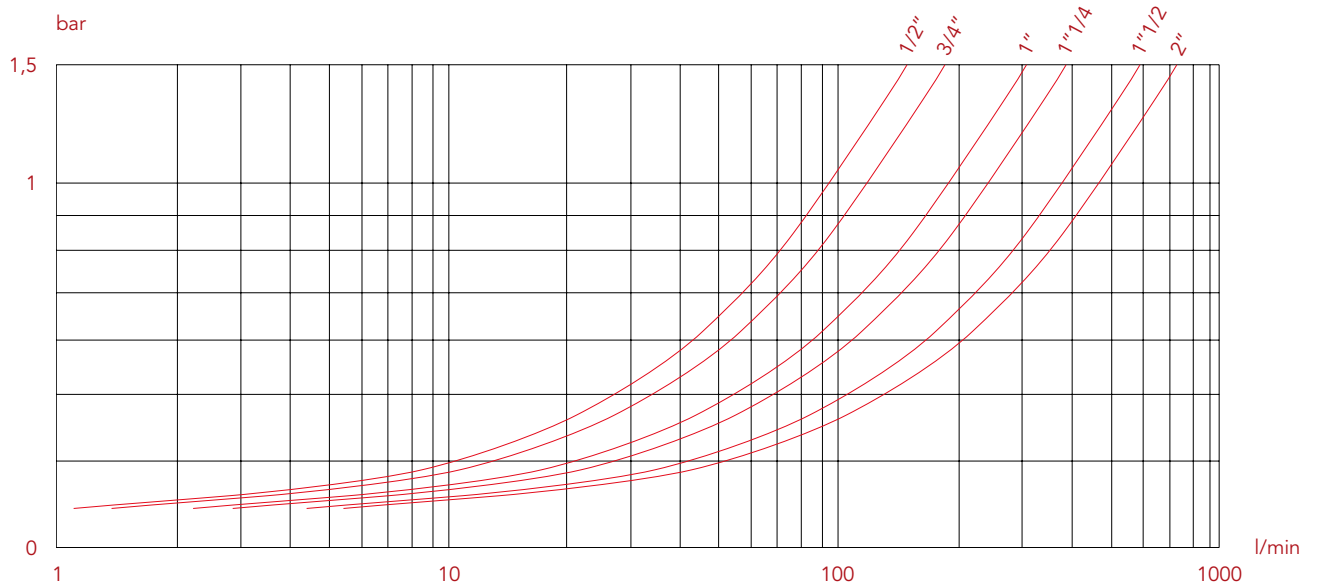

189CA

CARTRIDGE FOR SELF-CLEANING STRAINER
ART.189



SIZE	CODE	FOR STRAINER
1/2" (DN 15)	189CA012	1/2"
3/4" (DN 20)	189CA034	3/4"
1" (DN 25)	189CA100	1"
1"1/4 (DN 32)	189CA114	1"1/4
1"1/2 (DN 40)	189CA112	1"1/2
2" (DN 50)	189CA200	2"

TECHNICAL SPECIFICATIONS

Filtration degree: 300µm

MATERIALS

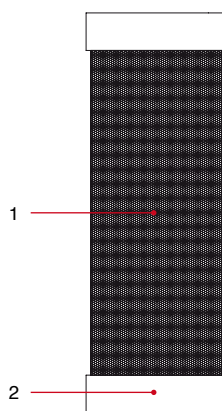

POS.	DESCRIPTION	N.	MATERIAL
1	Cartridge	-	Stainless steel AISI 304
2	End ring	-	NBR

OVERALL DIMENSIONS

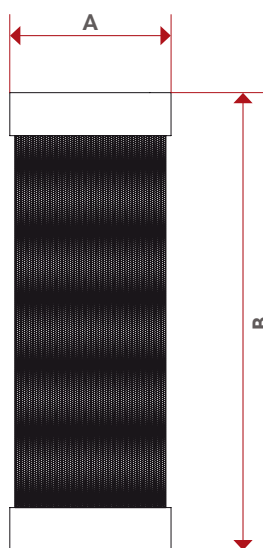

	1/2"	3/4"	1"	1"1/4	1"1/2	2"
DN	15	20	25	32	40	50
A	34	34	42	42	46	46
B	100	100	108	108	128	128



SELF-CLEANING STRAINER

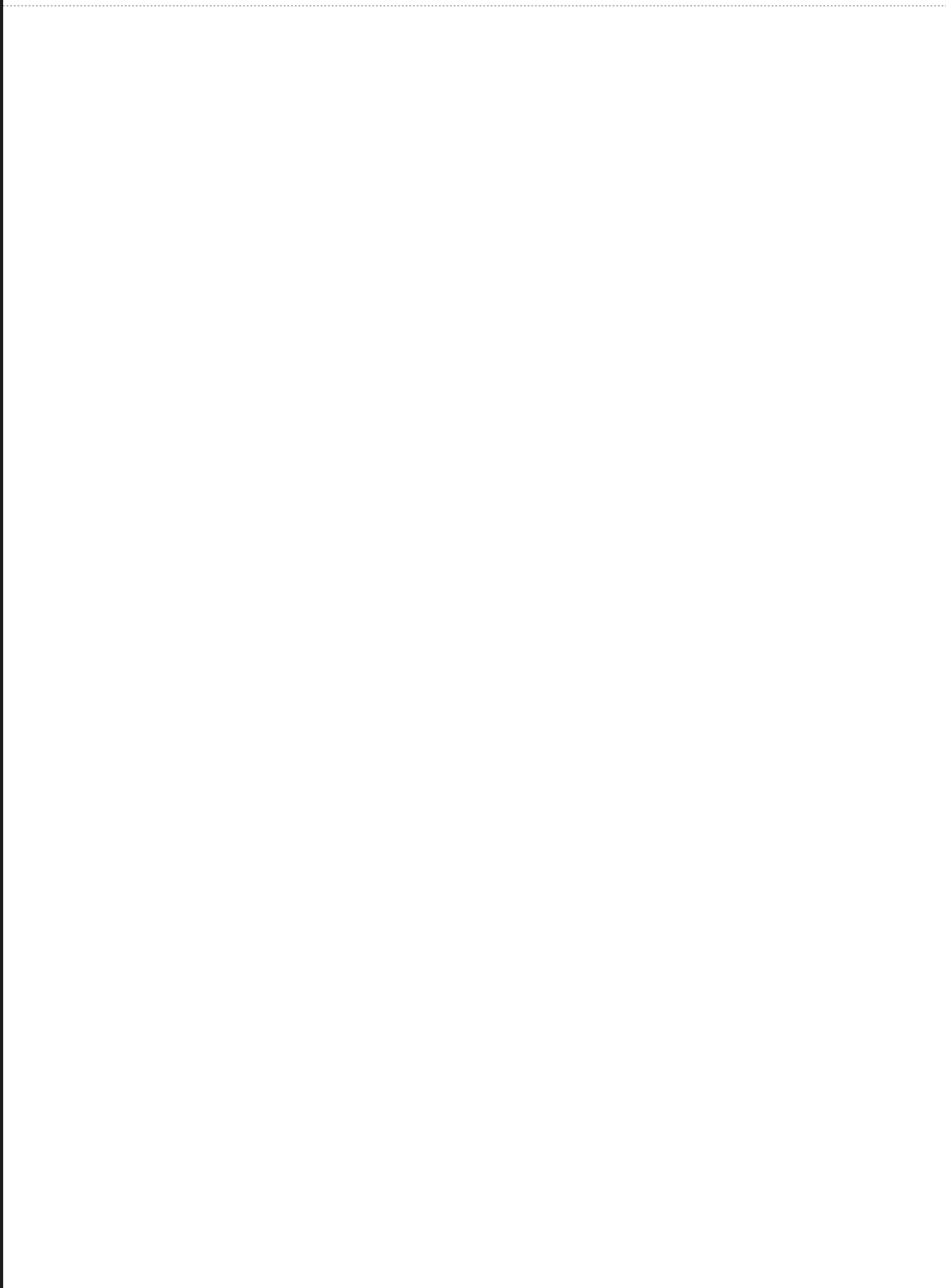



NOTES

Lined area for notes, consisting of multiple horizontal dashed lines.

STRAINERS

We reserve the right to make improvements and changes to the products described herein and to the relative technical data, at any time and without forewarning.



ITAP S.p.A.
Via Ruca 19
25065 Lumezzane
Brescia (ITALIA)
Tel 030 89270
Fax 030 8921990
www.itap.it - info@itap.it