

TECHNICAL CATALOGUE

BALL VALVES:
VIENNA®





ITAP SpA, founded in Lumezzane (Brescia) in 1972, is currently one of the leading production companies in Italy of valves, fittings and distribution manifolds for plumbing and heating systems. Thanks to fully automated production processes, with 63 tooling machines and 25 assembly lines, we are able to produce 150,000 pieces per day. Our innate pursuit for innovation and observance of technical regulations in force is supported by the company certification ISO 9001: 2008. The company has always considered its focus on quality as the main tool to obtaining significant business results: today ITAP SpA is proud to offer products bearing the approval of numerous international certifying bodies.





STANDARD FLOW
BALL VALVES:
VIENNA®

SUITABLE FOR DOMESTIC
WATER SERVICES, HEATING, AIR-
CONDITIONING PLANTS AND
COMPRESSED AIR SYSTEMS.

116

VIENNA® BALL VALVE,
STANDARD FLOW



SIZE	PRESSURE	CODE	PACKING
1/4" (DN 8)	50bar/725psi	0900014/N	12/192
3/8" (DN 10)	50bar/725psi	0900038/N	12/192
1/2" (DN 15)	30bar/435psi	1160012	15/120
3/4" (DN 20)	30bar/435psi	1160034	8/104
1" (DN 25)	30bar/435psi	1160100	8/64
1"1/4 (DN 32)	25bar/362,5psi	1160114	4/32
1"1/2 (DN 40)	25bar/362,5psi	1160112	4/32
2" (DN 50)	25bar/362,5psi	1160200	2/16

TECHNICAL SPECIFICATIONS

Female/female threads.

Lever handle in steel.

Body in nickel-plated brass.

Minimum and maximum working temperatures:

-20°C, 150°C in absence of steam.

Threads ISO228

(equivalent to DIN EN ISO 228 and BS EN ISO 228).

MATERIALS

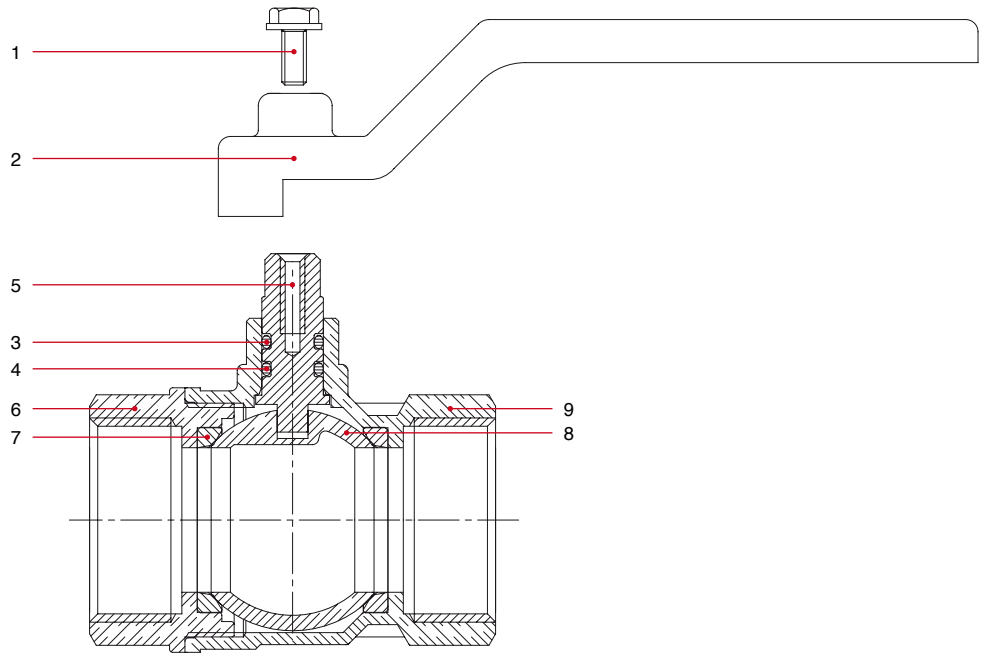

POS.	DESCRIPTION	N.	MATERIAL
1	Screw	1	Zinc-plated steel Fe CB4
2	Lever handle	1	Zinc-plated and varnished steel Fe.P04
3	O-Ring	1	VITON®
4	O-Ring	1	NBR
5	Stem	1	Brass CW614N
6	End adapter	1	Nickel-plated brass CW617N
7	Seat	2	P.T.F.E.
8	Ball	1	Chrome-plated brass CW617N
9	Body	1	Nickel-plated brass CW617N



117

VIENNA® BALL VALVE, STANDARD FLOW



SIZE	PRESSURE	CODE	PACKING
1/4" (DN 8)	50bar/725psi	0910014/N	12/192
3/8" (DN 10)	50bar/725psi	0910038/N	12/192
1/2" (DN 15)	30bar/435psi	1170012	15/120
3/4" (DN 20)	30bar/435psi	1170034	8/64
1" (DN 25)	30bar/435psi	1170100	8/64
1"1/4 (DN 32)	25bar/362,5psi	1170114	4/32
1"1/2 (DN 40)	25bar/362,5psi	1170112	4/24
2" (DN 50)	25bar/362,5psi	1170200	2/12

TECHNICAL SPECIFICATIONS

Male/female threads.
Lever handle in steel.
Body in nickel-plated brass.
Minimum and maximum working temperatures:
-20°C, 150°C in absence of steam.
Threads ISO228
(equivalent to DIN EN ISO 228 and BS EN ISO 228).

MATERIALS

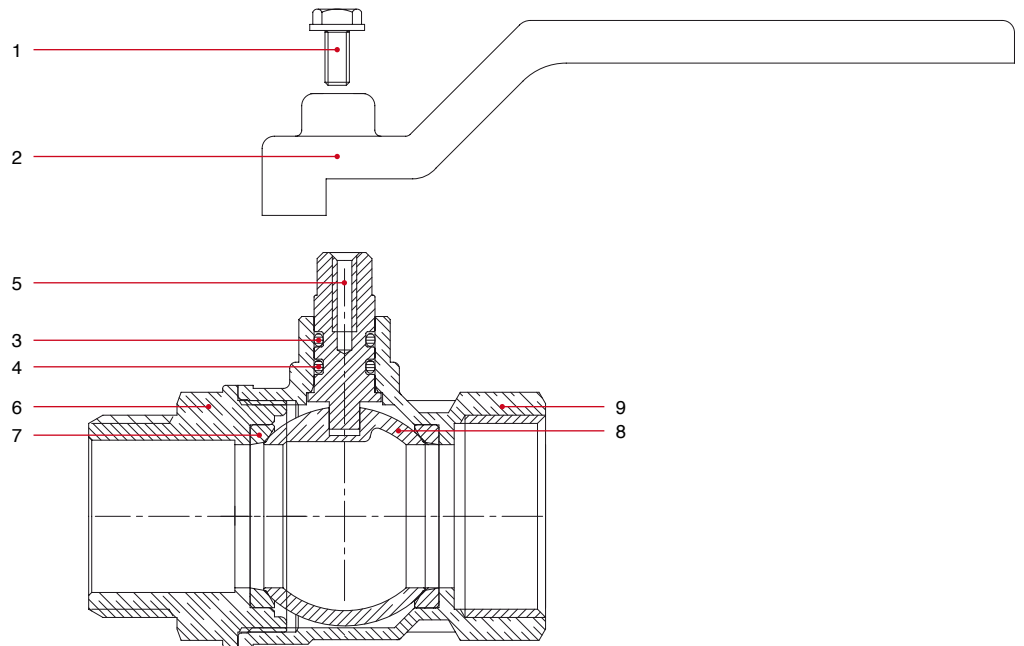

POS.	DESCRIPTION	N.	MATERIAL
1	Screw	1	Zinc-plated steel Fe CB4
2	Lever handle	1	Zinc-plated and varnished steel Fe.P04
3	O-Ring	1	VITON®
4	O-Ring	1	NBR
5	Stem	1	Brass CW614N
6	End adapter	1	Nickel-plated brass CW617N
7	Seat	2	P.T.F.E.
8	Ball	1	Chrome-plated brass CW617N
9	Body	1	Nickel-plated brass CW617N



118

VIENNA® BALL VALVE,
STANDARD FLOW



SIZE	PRESSURE	CODE	PACKING
1/4" (DN 8)	50bar/725psi	0920014/N	15/240
3/8" (DN 10)	50bar/725psi	0920038/N	15/240
1/2" (DN 15)	30bar/435psi	1180012	15/195
3/4" (DN 20)	30bar/435psi	1180034	8/88
1" (DN 25)	30bar/435psi	1180100	8/64

TECHNICAL SPECIFICATIONS

Female/female threads.
T handle in aluminium.
Body in nickel-plated brass.
Minimum and maximum working temperatures:
-20°C, 150°C in absence of steam.
Threads ISO228
(equivalent to DIN EN ISO 228 and BS EN ISO 228).

MATERIALS

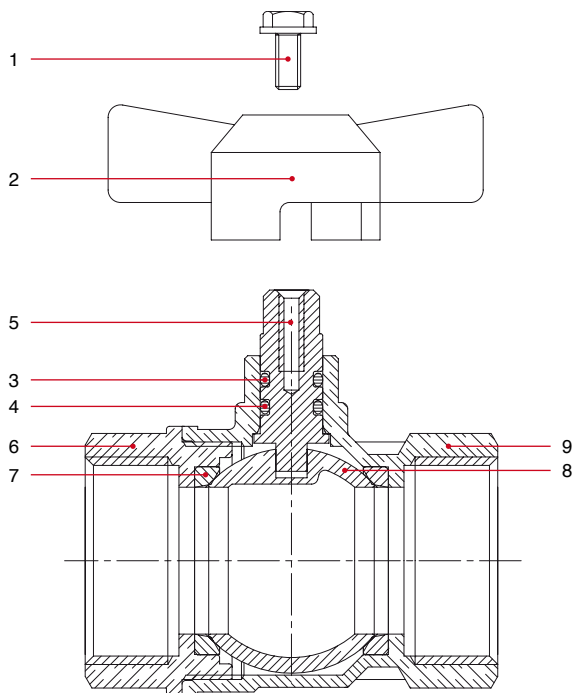

POS.	DESCRIZIONE	Q.tà	MATERIALE
1	Screw	1	Zinc-plated steel Fe CB4
2	T handle	1	Aluminium
3	O-Ring	1	VITON®
4	O-Ring	1	NBR
5	Stem	1	Brass CW614N
6	End adapter	1	Nickel-plated brass CW617N
7	Seat	2	P.T.F.E.
8	Ball	1	Chrome-plated brass CW617N
9	Body	1	Nickel-plated brass CW617N



119

VIENNA® BALL VALVE,
STANDARD FLOW



SIZE	PRESSURE	CODE	PACKING
1/4" (DN 8)	50bar/725psi	0930014/N	15/165
3/8" (DN 10)	50bar/725psi	0930038/N	15/165
1/2" (DN 15)	30bar/435psi	1190012	15/120
3/4" (DN 20)	30bar/435psi	1190034	8/88
1" (DN 25)	30bar/435psi	1190100	8/64

TECHNICAL SPECIFICATIONS

Male/female threads.
T handle in aluminium.
Body in nickel-plated brass.
Minimum and maximum working temperatures:
-20°C, 150°C in absence of steam.
Threads ISO228
(equivalent to DIN EN ISO 228 and BS EN ISO 228).

MATERIALS

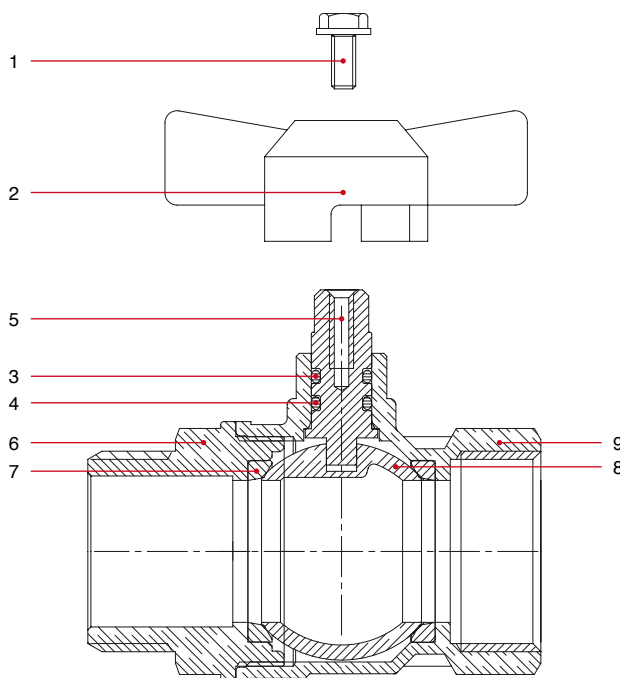

POS.	DESCRIZIONE	Q.tà	MATERIALE
1	Screw	1	Zinc-plated steel Fe CB4
2	T handle	1	Aluminium
3	O-Ring	1	VITON®
4	O-Ring	1	NBR
5	Stem	1	Brass CW614N
6	End adapter	1	Nickel-plated brass CW617N
7	Seat	2	P.T.F.E.
8	Ball	1	Chrome-plated brass CW617N
9	Body	1	Nickel-plated brass CW617N



OVERALL DIMENSIONS

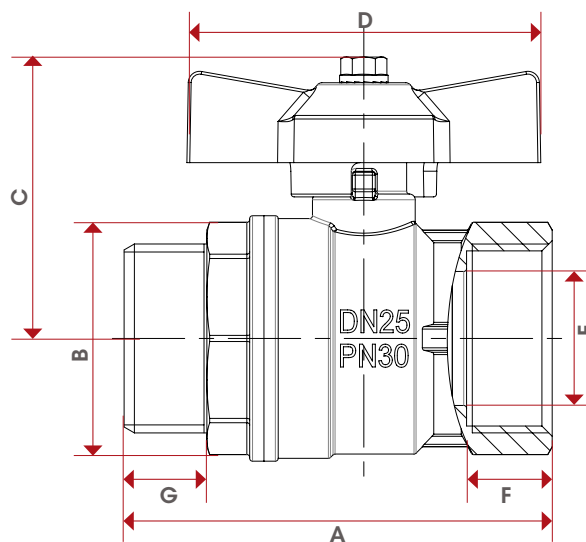

	1/4"	3/8"	1/2"	3/4"	1"
DN	8	10	15	20	25
A	54	54	58	62,5	75
B	23,5	24	29	36	43
C	37	37	40	46	49
D	47	47	47	54	62
E	8	10	14	18,5	23,5
F	10	10	12	12	15
G	10,5	10,5	11,5	12,5	14,5
Kg/cm ² bar	50	50	30	30	30
LBS - psi	725	725	435	435	435

CERTIFICATIONS



216

VIENNA® BALL VALVE, STANDARD FLOW



SIZE	PRESSURE	CODE	PACKING
1/4" (DN 8)	50bar/725psi	2160014	12/192
3/8" (DN 10)	50bar/725psi	2160038	12/192
1/2" (DN 15)	30bar/435psi	2160012	15/120
3/4" (DN 20)	30bar/435psi	2160034	8/64
1" (DN 25)	30bar/435psi	2160100	8/64
1"1/4 (DN 32)	25bar/362,5psi	2160114	4/32
1"1/2 (DN 40)	25bar/362,5psi	2160112	4/24
2" (DN 50)	25bar/362,5psi	2160200	2/18

TECHNICAL SPECIFICATIONS

Female/female threads.
 Flat lever handle in lined steel.
 Body in nickel-plated brass.
 Minimum and maximum working temperatures:
 -20°C, 150°C in absence of steam.
 Threads ISO228
 (equivalent to DIN EN ISO 228 and BS EN ISO 228).

MATERIALS

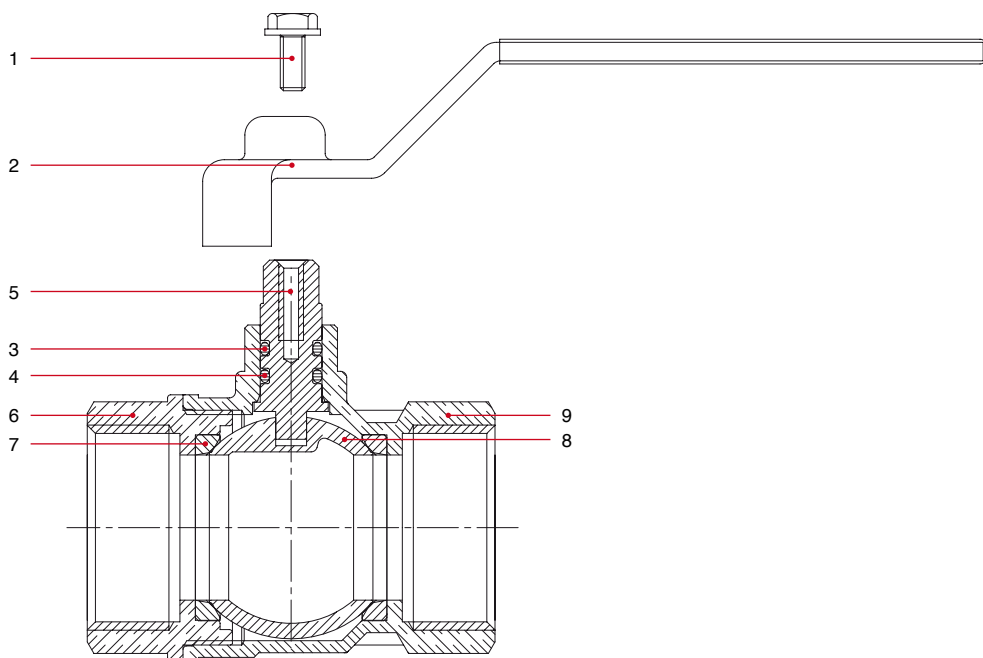

POS.	DESCRIZIONE	Q.tà	MATERIALE
1	Screw	1	Zinc-plated steel Fe CB4
2	Flat lever handle	1	Zinc-plated steel Fe.P04
3	O-Ring	1	VITON®
4	O-Ring	1	NBR
5	Stem	1	Brass CW614N
6	End adapter	1	Nickel-plated brass CW617N
7	Seat	2	P.T.F.E.
8	Ball	1	Chrome-plated brass CW617N
9	Body	1	Nickel-plated brass CW617N



OVERALL DIMENSIONS

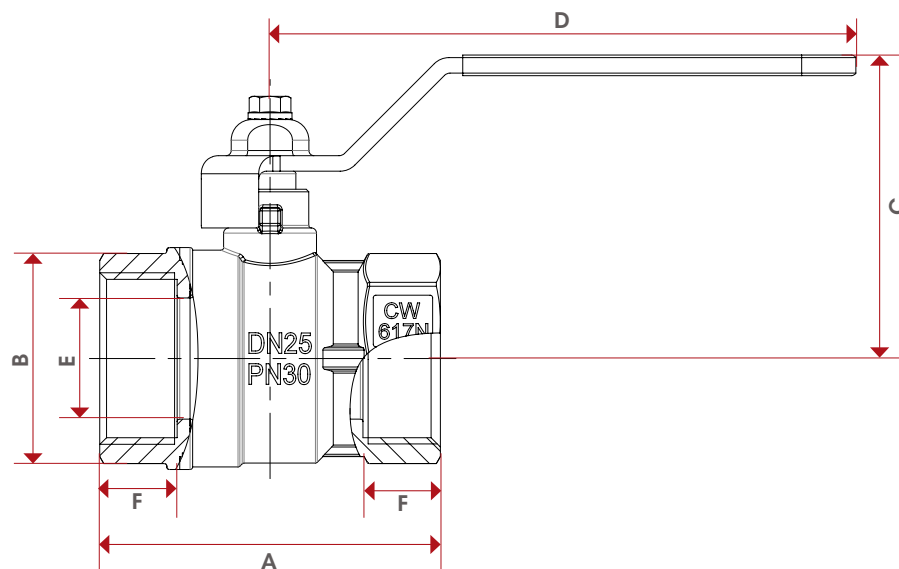

	1/4"	3/8"	1/2"	3/4"	1"	1"1/4	1"1/2	2"
DN	8	10	15	20	25	32	40	50
A	44,4	44,4	48	53	66	76	88	103
B	23,5	24	29	36	43	53	63	79
C	42	42	44	55	59	74	79	95
D	85,5	85,5	85,5	113,5	113,5	138	138	157,5
E	10	10	14	18,5	23,5	30	37	47
F	10	10	12	12	15	16	18	19
Kg/cm ² bar	50	50	30	30	30	25	25	25
LBS - psi	725	725	435	435	435	362,5	362,5	362,5

CERTIFICATIONS



217

VIENNA® BALL VALVE,
STANDARD FLOW



SIZE	PRESSURE	CODE	PACKING
1/4" (DN 8)	50bar/725psi	2170014	12/156
3/8" (DN 10)	50bar/725psi	2170038	12/156
1/2" (DN 15)	30bar/435psi	2170012	15/120
3/4" (DN 20)	30bar/435psi	2170034	8/64
1" (DN 25)	30bar/435psi	2170100	8/64
1"1/4 (DN 32)	25bar/362,5psi	2170114	4/32
1"1/2 (DN 40)	25bar/362,5psi	2170112	4/28
2" (DN 50)	25bar/362,5psi	2170200	2/12

TECHNICAL SPECIFICATIONS

Male/female threads.
Flat lever handle in lined steel.
Body in nickel-plated brass.
Minimum and maximum working temperatures:
-20°C, 150°C in absence of steam.
Threads ISO228
(equivalent to DIN EN ISO 228 and BS EN ISO 228).

MATERIALS

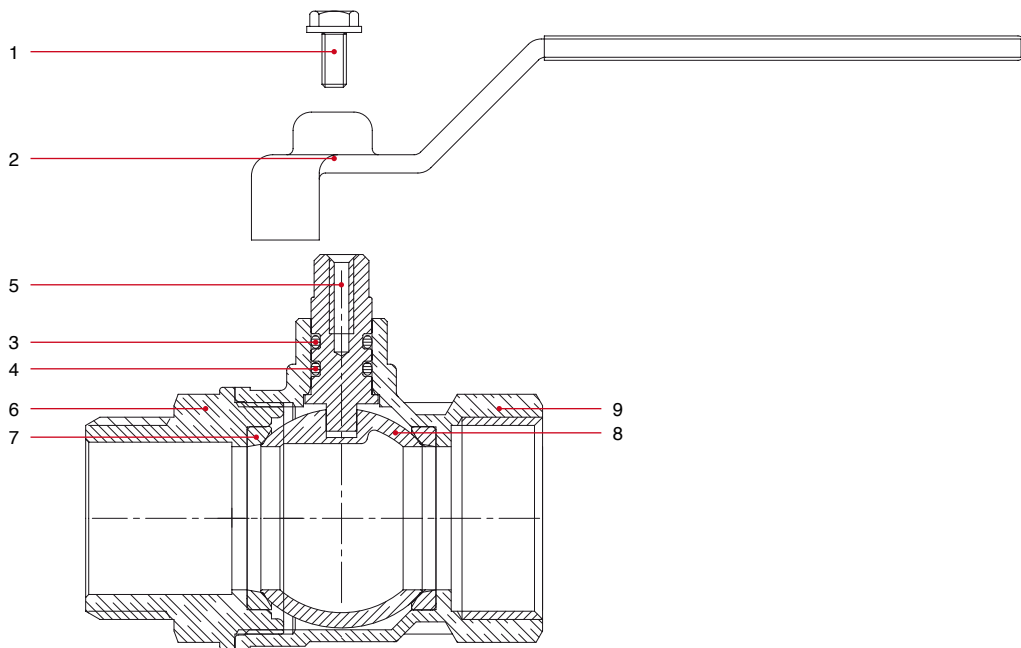

POS.	DESCRIZIONE	Q.tà	MATERIALE
1	Screw	1	Zinc-plated steel Fe CB4
2	Flat lever handle	1	Zinc-plated steel Fe.P04
3	O-Ring	1	VITON®
4	O-Ring	1	NBR
5	Stem	1	Brass CW614N
6	End adapter	1	Nickel-plated brass CW617N
7	Seat	2	P.T.F.E.
8	Ball	1	Chrome-plated brass CW617N
9	Body	1	Nickel-plated brass CW617N



OVERALL DIMENSIONS

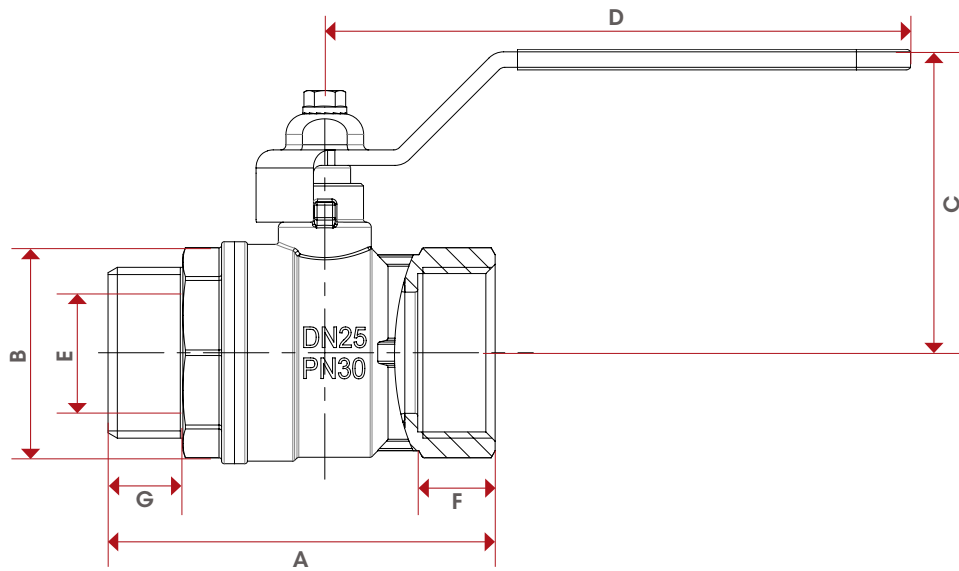

	1/4"	3/8"	1/2"	3/4"	1"	1 1/4"	1 1/2"	2"
DN	8	10	15	20	25	32	40	50
A	54	54	58	62,5	75	87,5	100,5	115,5
B	23,5	24	29	36	43	53	63	79
C	42	42	44	55	59	74	79	95
D	85,5	85,5	85,5	113,5	113,5	138	138	157,5
E	8	10	14	18,5	23,5	30	37	47
F	10	10	12	12	15	16	18	19
G	10,5	10,5	11,5	12,5	14,5	17	19	21
Kg/cm ² bar	50	50	30	30	30	25	25	25
LBS - psi	725	725	435	435	435	362,5	362,5	362,5

CERTIFICATIONS



FLOW RATE AND PRESSURE DROP CHART

WITH WATER

Art: 116 - 117 - 118 - 119 - 216 - 217

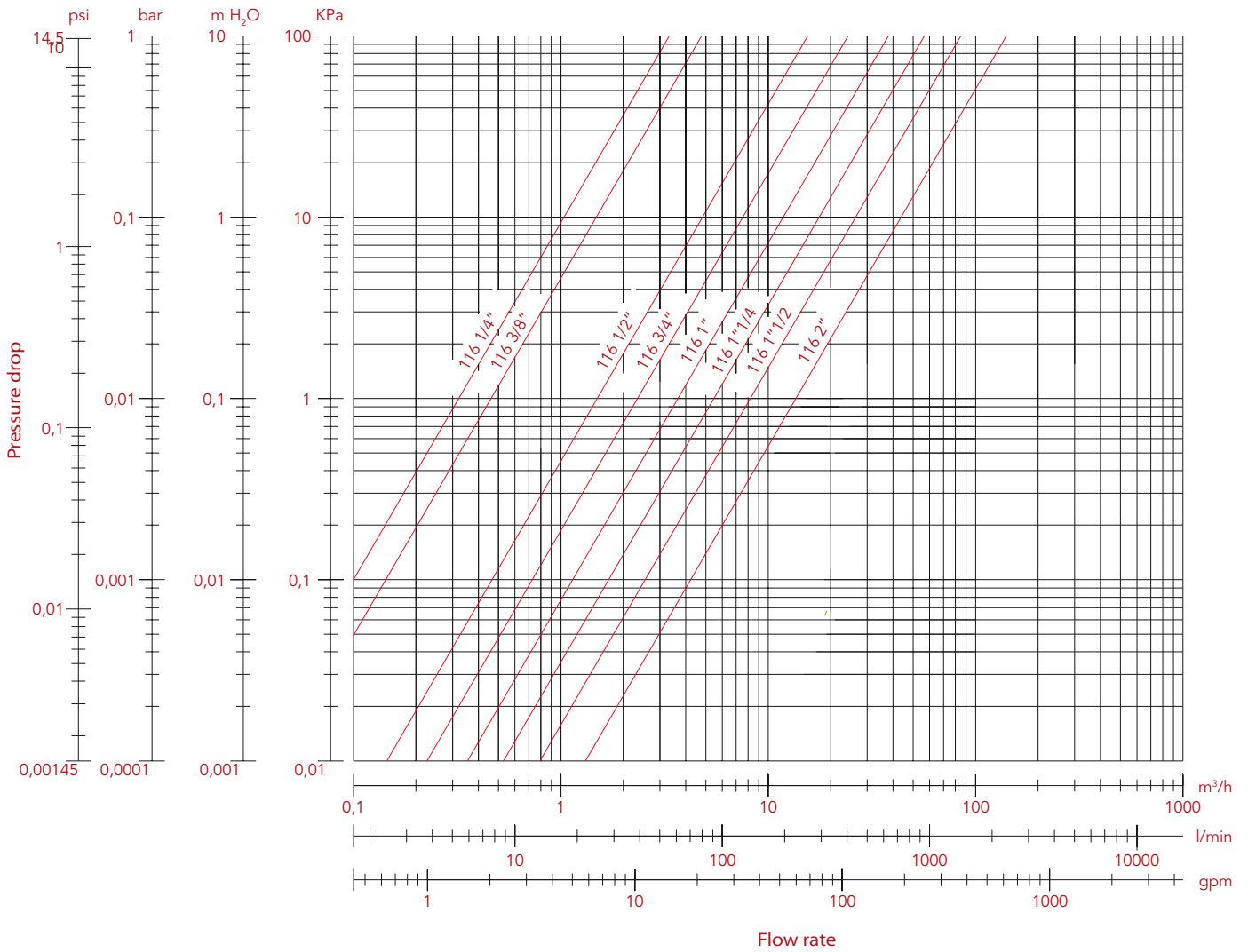

SIZE	1/4"	3/8"	1/2"	3/4"	1"	1 1/4"	1 1/2"	2"
Ø	10	10	14	18,5	23,5	30	37	47
Kv	3,33	4,92	14,65	23,46	38,67	56,07	86,60	160,25



PRESSURE-TEMPERATURE DIAGRAM

BALL VALVES

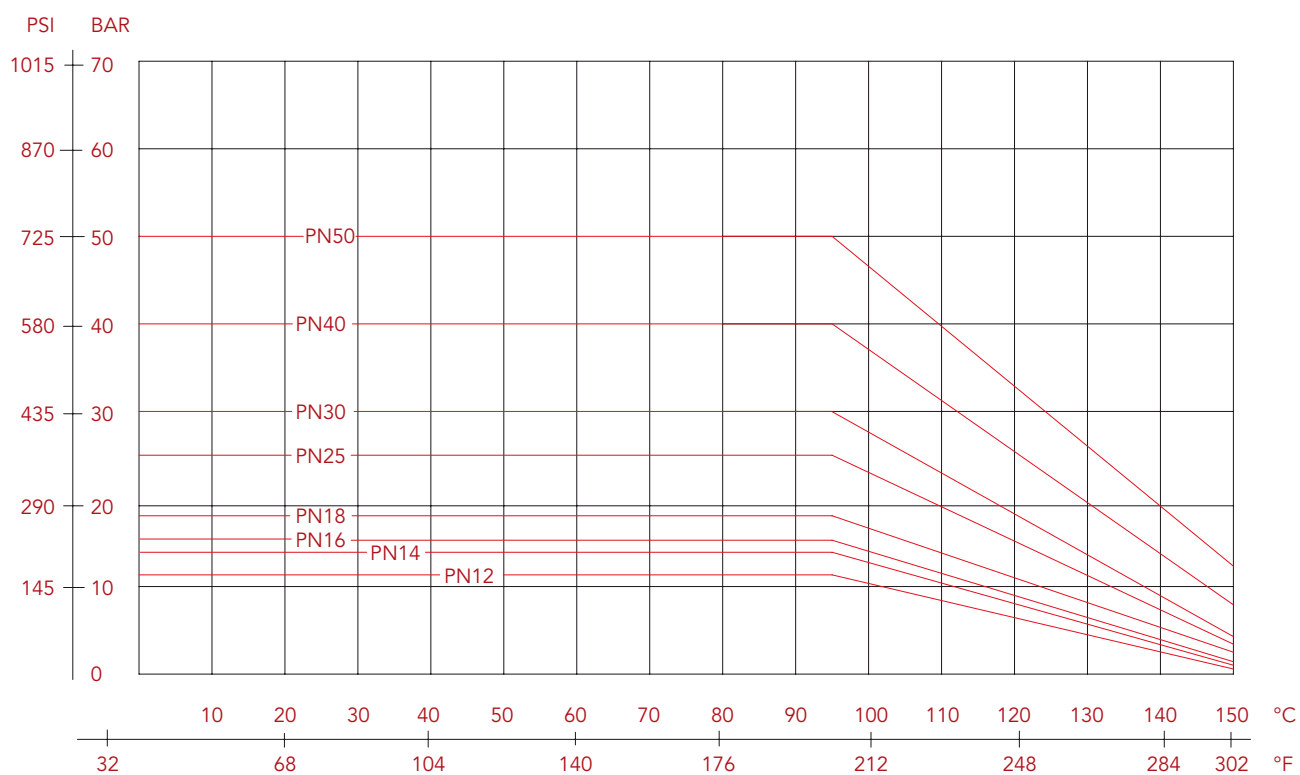

The values shown by the dropping lines state the maximum limit of employment of the valves.
The shown valves are approximate.

MANUFACTURER INSTRUCTIONS

Installation

The itap S.p.A.'s valves are bi-directional, that means they manage the flow in both the directions. The valves are composed by a ball, two seal in PTFE material, one stem, two sailing rings (O-Rings), one handle and a couple of parts made of brass (body and end adopter) that contain them and that are assembled by means of threat and a sealed material to obtain their aim. To avoid that the sealing material gets brake and than the valve gets lose the connection between body and the end adopter, it's necessary to avoid to submit the two parts under the influence of a torque.

For their installation ones have to use the normal hydraulic practices, and in particular:

- Ones have to be sure that the two pipes are correctly aligned,
- during the assembling ones have to apply the assembling tool at the end that is nearest to the pipe,
- the application of the sealing materials by the fitter (PTFE or hempen cloth) must be limited at the threat zone. An excess should interferes in the ball-gasket's closure zone, compromising the tightness.
- In the case that the fluid transported presents some impurities (dust, water too hard, etc.) ones have to remove these impurities by the means of a filter. Otherwise they could damage the seals.

Disassembly the installed valve

To remove the valve from the pipe line or anyhow before to unscrew the junctions linked to it:

- wear the clothing protective normally required to work with the fluid transported within the line.
- Depressurize the line and operate in this way:
 - positioning the valve in opened position and than empty the line
 - handle the valve to put down the residue pressure contained inside the space between the ball and the body before of remove it from the line,
 - during the disassembly apply the screw tool at the end of the valve nearest the pipe

Maintenance

Verify the valves periodically, in function oh their application's field and in function of their work conditions, to be sure that the valves work correctly.





TEC

VIENNA®



STANDARD FLOW BALL VALVES: VIENNA®





NOTES

Lined area for notes with horizontal dashed lines.



ITAP S.p.A.
Via Ruca 19
25065 Lumezzane
Brescia (ITALIA)
Tel 030 89270
Fax 030 8921990
www.itap.it - info@itap.it