

# ECOJET

HYGIENE

## Ecological and high speed hand dryer



White finish

Inox finish



### TECHNICAL SPECIFICATIONS

RPM	30.000
Air velocity (Km/h)	410
Air temperature	40°C
Total Power (W)	420 - 1.100
Power consumption (A)	3,2 - 5
Noise level (dBA) a 2 m	65 - 68
Voltage (V)	220 - 240
Frequency (Hz)	50 - 60
Electrical insulation	Classe II
Drying time	8 - 10 sec.
Weight (Kg)	8,3
Protection	IPX4

- Exclusive design
- ABS cover
- 4 air scatterers
- 2 IR sensors
- Drying time: 8 sec
- Air velocity: 410 km/h at 40°C
- Energy saving: no heating element



Dry hands in 8 seconds!

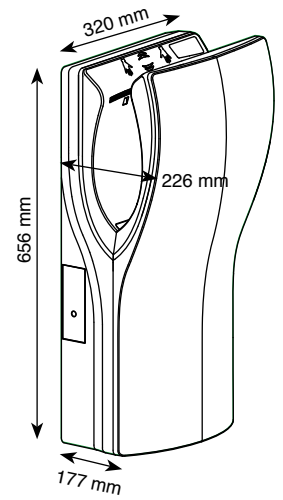

# ECOFLOW

HYGIENE

## Ecological and high speed hand dryer



Steel AISI 304

ECOFLOW  
Automatic  
steel white finish

ECOFLOW X  
Automatic steel inox



### TECHNICAL SPECIFICATIONS

Airflow (m³/h)	187
RPM	19.000 - 30.000
Air velocity (Km/h)	325
Air temperature	40° C
Total power (W)	420 - 1150
Power consumption (A)	3,3 - 4,7
Noise level (dBA)	68-75 dB
Voltage (V)	220-240 V
Frequency (Hz)	50-60
Electrical insulation	Classe I
Drying time	12 sec
Weight	4,7 Kg
Protection	IP23

- Compact, one-piece steel cover
- Sensor operated for a complete automatic operation
- Drying time: 8-12 sec.
- Energy saving: no heating element
- Air velocity: 325 km/h at 40°C

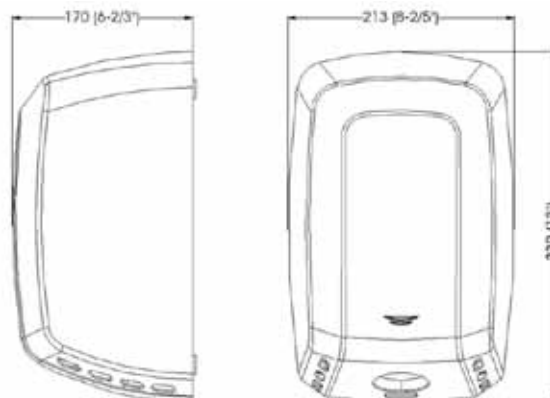

# HD300

## HYGIENE ANTI-VANDAL Hand Dryer



**HD300A**  
Automatic white or inox finish

**Automatic**  
Sensor operated (adjustable through internal trimmer)  
Optimized energy consumption: immediate stop after the hands are removed.



**HD300P**  
Manual white or inox finish

**Manual**  
Push-button activation (electronic timer with a 35 seconds cycle).

Steel  
AISI 304



### TECHNICAL SPECIFICATIONS

Airflow (m <sup>3</sup> /h)	330
RPM	5500
Air velocity (Km/h)	96
Air temperature	53°C
Motor Power (W)	250
Heating element power (W)	2000
Consumption (A)	10
Noise level (dBA)	68
Voltage (V)	220-240
Frequency (Hz)	50/60
Electrical insulation	Classe I
Drying time	25 sec
Weight Kg	4,9 Kg (A) - 4,65 Kg (P)
Protection	IP23

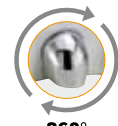

360°  
ORIENTATION

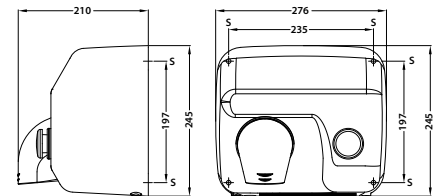

# HD100

## HYGIENE Classic Hand Dryer



**HD100A**  
Automatic



**HD100P**  
Manual



### TECHNICAL SPECIFICATIONS

Airflow (m <sup>3</sup> /h)	240
RPM	2.800
Air velocity (Km/h)	65
Air temperature	52°C
Motor Power (W)	140
Heating element power (W)	1500
Consumption (A)	7
Noise level (dBA)	58
Voltage (V)	220-240
Frequency (Hz)	50/60
Electrical insulation	Classe II -
Drying time	35 sec
Weight Kg	3 Kg
Protection	IP21

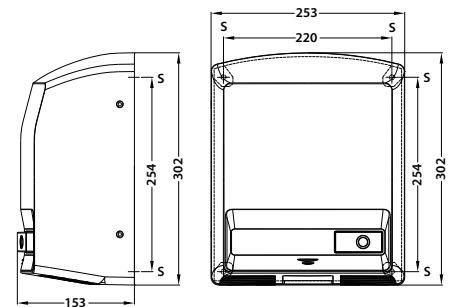

- Compact, one-piece cover made of UV resistant. ABS white plastic, 3 mm thick.
- Manual (40 sec. cycle) or Automatic.

# HR100

## HYGIENE Hair Dryer



### TECHNICAL SPECIFICATIONS

Airflow (m <sup>3</sup> /h)	40
RPM	15.000
Air velocity (Km/h)	79
Air temperature	60°C
Motor Power (W)	150
Heating element power (W)	700
Consumption (A)	3
Noise level (dBA)	60
Voltage (V)	220-240
Frequency (Hz)	50/60
Length tube (mm)	800 - 2000 mm
Weight Kg	1,8 Kg
Electrical insulation	Classe II -
Protection	IP23

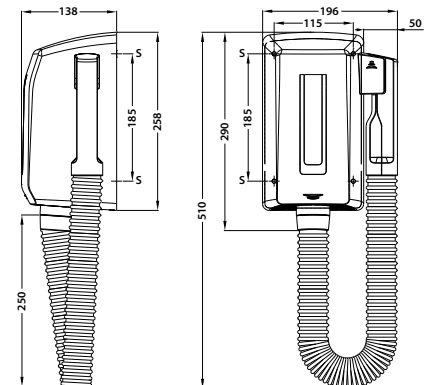

- Quick and easy installation.
- Automatically activates when hand piece is removed from the base.
- Fitted with a special security system which switches off the dryer after 15 min of use.
- High velocity airflow (79 Km/h) for a quick drying.
- White ABS plastic one-piece cover, 3 mm thick, impact-resistant and UV protected.