

 **SPARE PARTS MANUAL**
Model: RC64 (Type 104E [DW210E])

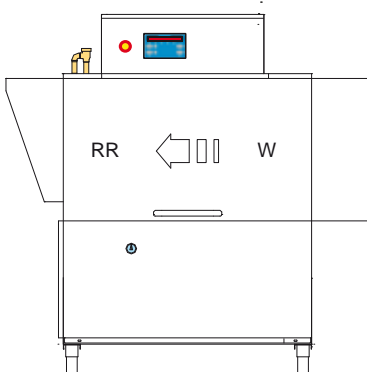
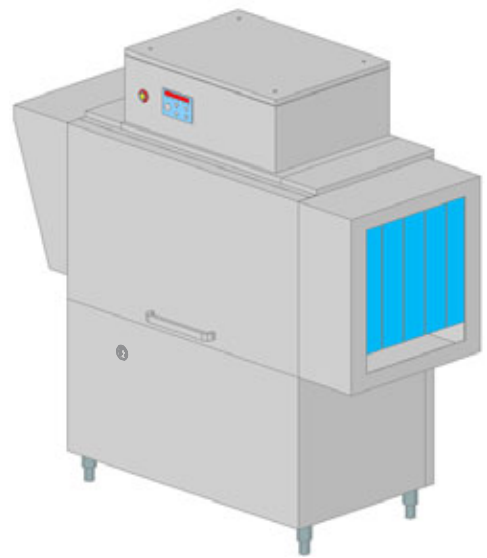
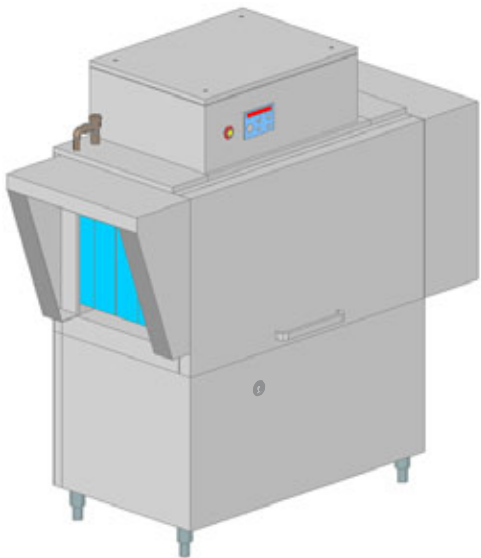

Parti di ricambio

Spare Parts

Catalogues pièces

Plezas de recambis

Ersatzteile

INFORMAZIONI GENERALI

Questo catalogo serve per richiedere con esattezza le parti di ricambio

Nelle ordinazioni indicare:

1) il numero dei codici dei particolari seguito dalla descrizione e la quantità desiderata;

2) Il codice alfa-numerico presente nella seconda colonna della tabella ;

I disegni delle parti di ricambio sono solo indicativi e non rappresentano il pezzo in oggetto.

I dati contenuti in questo catalogo sono indicativi e possono essere soggetti a modifiche senza impegno di preavviso.

ALLGEMEINE INFORMATIONEN

Dieser Ersatzteilkatalog dient zur genauen Angabe der Teile bei Ersatzteilbestellungen.

Bei Ersatzbestellung ist folgendes anzugeben:

1) Die Bestellnummer der Ersatzteile mit der entsprechenden Beschreibung genaue Menge;

2) Der alpha-numerischer Code auf der zweiten Reihe in dein Spult;

Die Zeichnungen der Ersatzteile sind nur als Hinweise gedacht und stellen nicht das betroffene Teil dar.

Bei den im Katalog angeführten Daten handelt es sich um Anhaltsdaten, die jederzeit, ohne Vorankündigung, geändert werden können.

GENERAL INFORMATION

The present spare parts order exactly the right spare parts

When ordering specify:

1) the part's code number followed by its description and quantity needed;

2) The alpha-numeric code is in the second column in the chart;

Spare parts drawings are general and do not represent the part.

The contents of this catalogue are general and can undergo changes without prior notice.

INFORMACIONES GENERALES

El presente catálogo sirve para pedir con exactitud las partes de repuesto

En los pedidos se debe indicar:

1) el número de código de la parte y a continuación la descripción cantidad deseada;

2) El código alfanumerico presente en la signada columna de la tabla;

Los diseños de las partes de recambio son solo indicativos y no representan la pieza en cuestión.

Los datos contenidos en el presente catálogo son indicativos y pueden modificarse sin aviso previo.

INFORMATIONS GENERALES

Ce catalogue permet de commander correctement les pièces détachées

Les commandes doivent être passées en indiquant:

1) le numero de code des pièces détachées suivi de leur description quantité désirée;

2) le code alphanumérique dans la deuxième colonne du tableau;

Les plans des pièces détachées sont fournis seulement à titre indicatif et ne représentent pas la pièce concernée.

Les données de ce catalogue sont citées seulement à titre indicatif et peuvent être l'objet de modifications sans avis préalable.

ESEMPIO EXAMPLE EXEMPLE BEISPIEL

ITEM / ID	CODICE / P-code
1	DW3000118
2	DW3000118/A
3	DW3000118/B
4	DW3000117

Note

Tutte le informazioni riportate si intendono aggiornate alla data di stampa. Il Produttore si riserva il diritto di apportare qualsiasi modifica richiesta dallo sviluppo evolutivo dei suddetti prodotti.

*Per la sicurezza ,la garanzia, l'affidabilità ed il valore della lavastoviglie usa solo ricambi originali. **Per alcuni codici, sono richieste quantità minime d'ordine.***

Attenzione

Questo libretto è parte integrante della lavastoviglie e, in caso di passaggio di proprietà, deve essere consegnato al nuovo acquirente.

Remarque

Toutes les informations contenues dans ce manuel s'entendent mises à jour à la date d'impression. En raison du développement constant de ses produits, usine se réserve le droit d'apporter à tout instant les modifications qu'elle jugera utiles.

*Pour la sécurité, la garantie, la fiabilité et la valeur de votre lavevaisselles, n'utilisez que des pièces de rechange d'origine. **Pour quelque référence on demande un minimum de pièces par commande***

Attention

Ce manuel doit être considéré comme partie intégrante de la lavevaisselles, en cas de transfert de propriété, doit toujours être remis au nouveau propriétaire.

Note

The information contained herein is valid at the time of going to print. The Company reserves the right to make any changes required by the future development of the above-mentioned products.

*For your safety, as well as to preserve the warranty reliability and worth of your dishwashers , use original spare parts only. **For some codes a minimum quantity for order is required.***

Warning

This manual forms an integral part of the dishwashers and - if a transfer of title occurs - must always be handed over to the new owner.

Hinweis

Die Der Hersteller behält sich das Recht vor, jegliche, durch eine Weiterentwicklung der genannten Produkte bedingte Änderungen vornehmen zu können.

*Verwenden Sie für Ihre Sicherheit, die Garantie, die Zuverlässigkeit und den Wert Ihrer machine originale Ersatzteile. **Für bestimmte Code nummer werden mindesten bestellungen verlangt.***

Achtung

Diese Betriebsanleitung ist Bestandteile des machine und muss bei seinem Weiterverkauf dem neuen Besitzer ausgehändigt werden.



Spare parts

1st WASH ZONE+RINSE ZONE (W+RR).....6

SPLASH ZONE (L=300 / L=500).....26

CONTROL PANEL.....32

SOLENOID VALVE ASSEMBLY.....40

DRAINAGE ASSEMBLIES.....43

CONVEYOR PARTS.....48

PUMP.....54

BREAK TANK & VACUUM BREAKER.....58

OVER FLOW PIPE.....63

ITEM / ID	(IT)	(EN)	(FR)
SG	PARASPRUZZI	SPLASH ZONE	SAS
AS	PREL.AUTOMATICO	PRE-WASH SHOWER	PRELAVAGE AUT.+TIROR
PW	PRELAVAGGIO	PRE-WASH	PRÉLAVAGE
W2	2°LAVAGGIO	SECOND WASH	2°LAVAGE
W1	1°LAVAGGIO	FIRST WASH	1°LAVAGE
RR	RISCIACQUO POT.	POWER RINSE	RINÇAGE PLUS
CP	PANNELLO COM.	CONTROL PANELL	PANNEAU DE CONTROLÉ
D	ASCIUGATURA	DRYER	SECHAGE

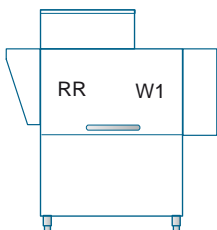

Parti di ricambio

Spare Parts

Catalogues pièces

Plezas de recambis

Ersatzteile



Code DW 009M.0001 **CL/Part**

Model DESCRIPTION 

S/N DW A 1000001 **Type**

400V 3N 50HZ 8A
3500W 500W

 16A

IPX3

Pressione Dinamica alimentazione idrica 200-500 kPa
Pression dynamique arrivèe d'eau
Dynamic pressure water supply
Dynamischer Druck asserreinlauf

Pressione dinamica vapore saturo
Pression dynamique vapore satueèe
Dymanischer Druck gesattigter Dampf
Pression Dinamica Vapor Saturado

TECHICAL SPECIFICATION



MADE IN ITALY

Temperatura massima acqua in ingresso 60°C
Temperature max eau a l'entre
Maximale Temperatur Wasseranschlu
Maximum Water temperature in-feeding

Model 

S/N 

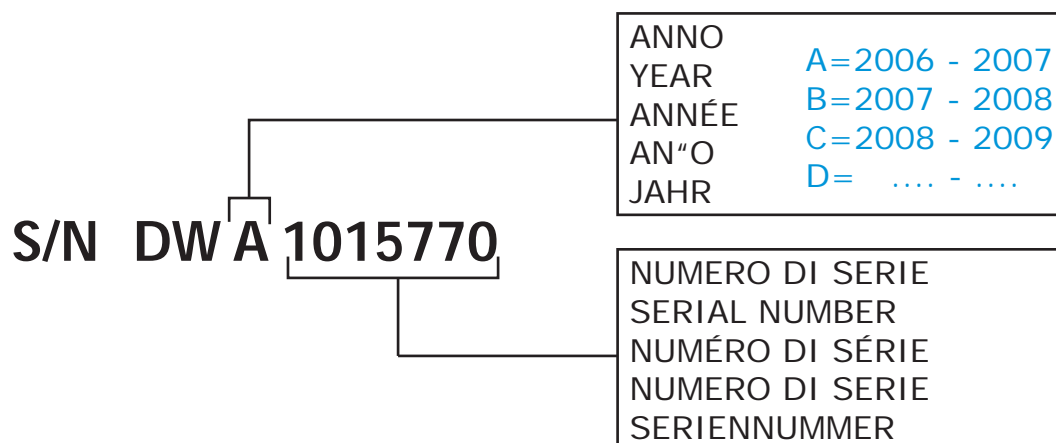
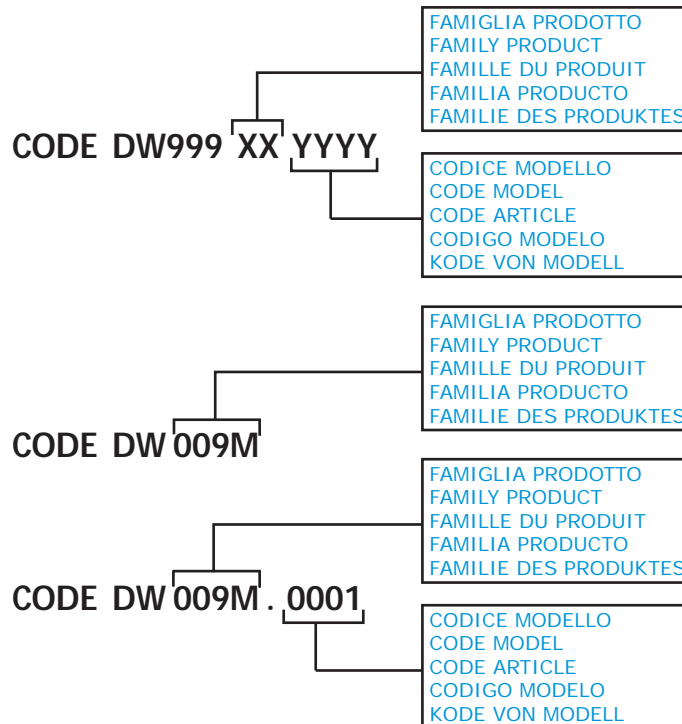

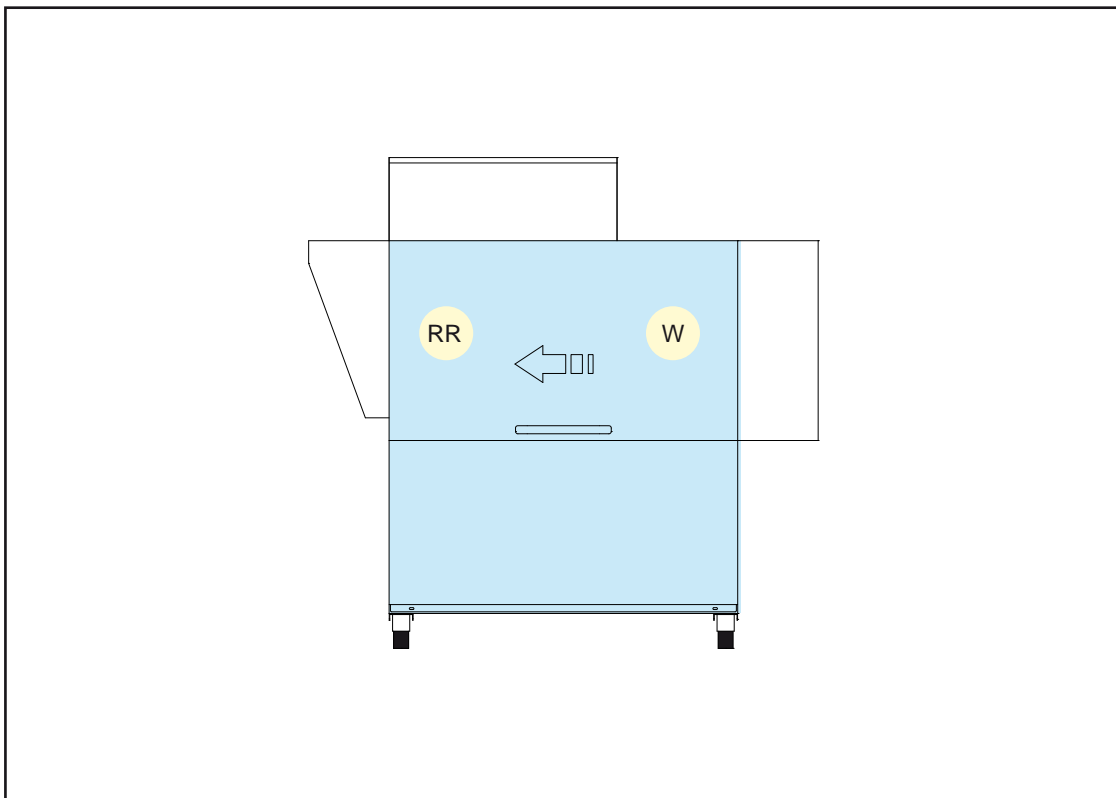

 — **1st WASH ZONE+RINSE ZONE (RR + W)**

ITEM / ID	(IT)	(EN)	(FR)
SG	PARASPRUZZI	SPLASH ZONE	SAS
AS	PREL.AUTOMATICO	PRE-WASH SHOWER	PRELAVAGE AUT.+TIROR
PW	PRELAVAGGIO	PRE-WASH	PRÉLAVAGE
W2	2°LAVAGGIO	SECOND WASH	2°LAVAGE
W1	1°LAVAGGIO	FIRST WASH	1°LAVAGE
RR	RISCIACQUO POT.	POWER RINSE	RINÇAGE PLUS
CP	PANNELLO COM.	CONTROL PANELL	PANNEAU DE CONTRÔLE
D	ASCIUGATURA	DRYER	SECHAGE

DWG-XXX
Rev.00 - 05/2017

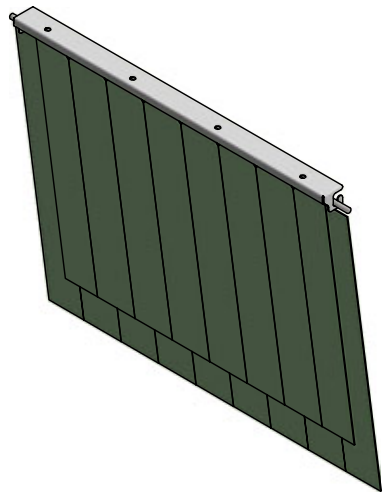
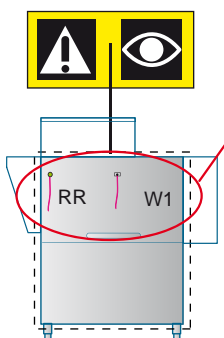
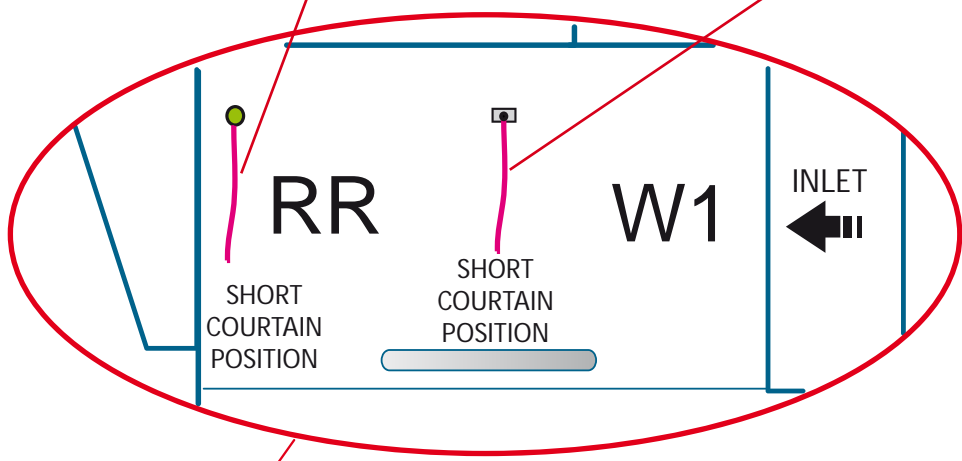
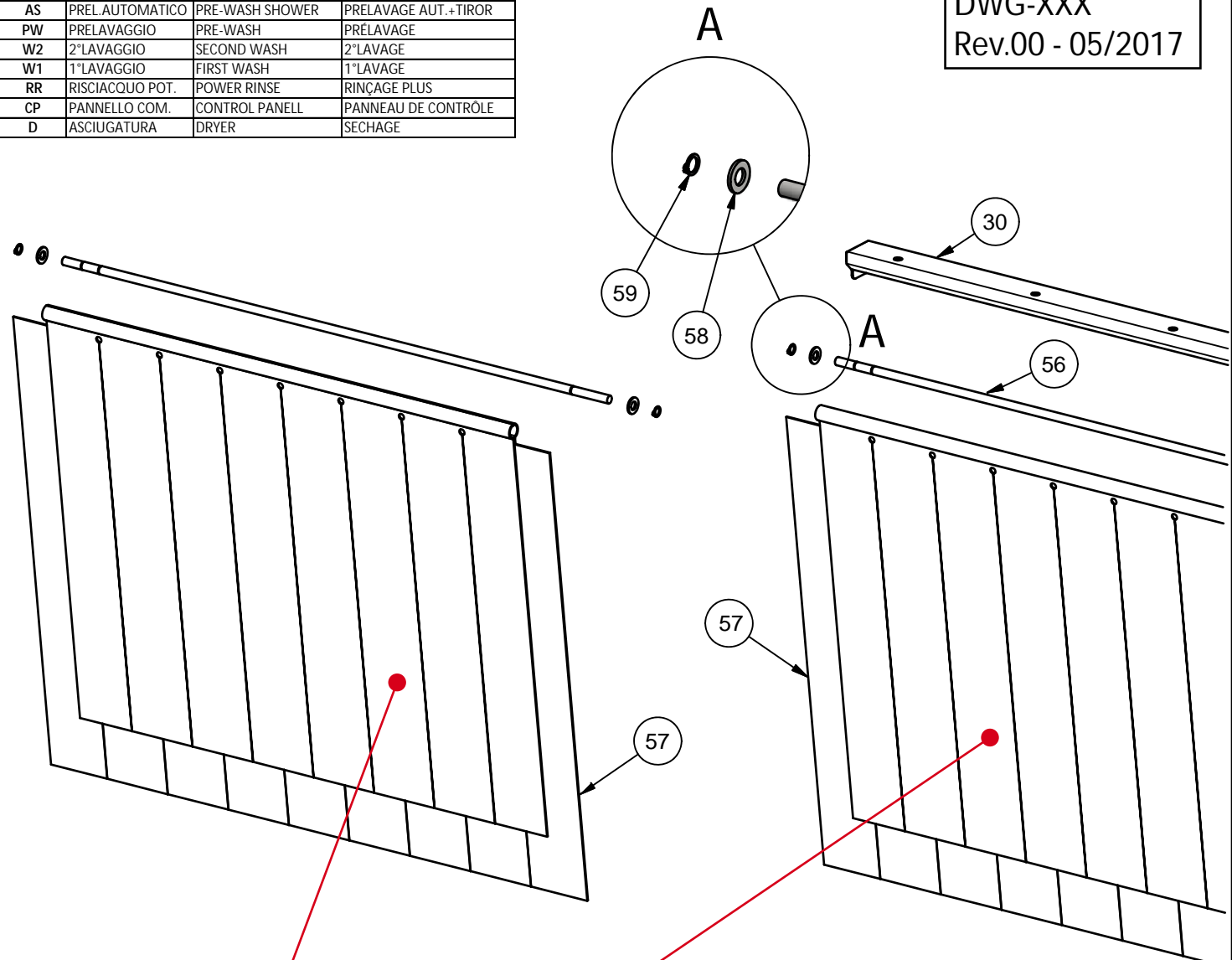



ITEM / ID	CODICE / P-code	DESCRIPTION (EN)	Q.TA'/Q.TY
30	DW3070199	CURTAIN SUPPORT	1
56	DW3004052	CURTAIN ROD	1
57	DW3071072	CURTAIN	1
58	DW11185	INOX WASHER 8x16 DIN125	2
59	DW11815	SEEGER Ø8 INOX UNI 7435	2

ITEM / ID	(IT)	(EN)	(FR)
SG	PARASPRUZZI	SPLASH ZONE	SAS
AS	PREL. AUTOMATICO	PRE-WASH SHOWER	PRELAVAGE AUT. + TROR
PW	PRELAVAGGIO	PRE-WASH	PRELAVAGE
W2	2 ^o LAVAGGIO	SECOND WASH	2 ^e LAVAGE
W1	1 ^o LAVAGGIO	FIRST WASH	1 ^{er} LAVAGE
RR	RISCIACQUO POT.	POWER RINSE	RINÇAGE PLUS
CP	PANNELLO COM.	CONTROL PANEL	PANNEAU DE CONTRÔLE
D	ASCIUGATURA	DRYER	SECHAGE

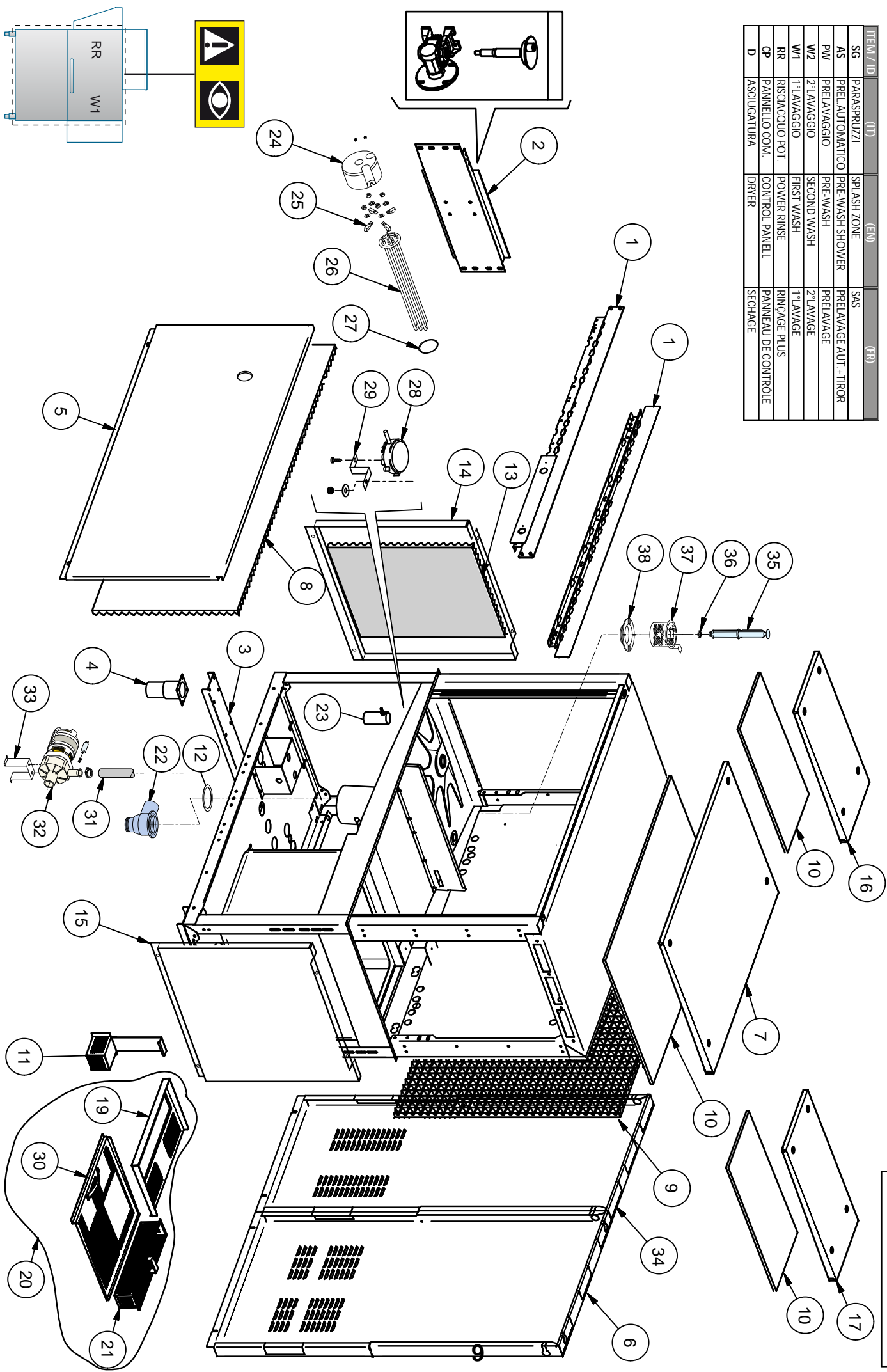



ITEM / ID	CODICE / P-code	DESCRIPTION (EN)	Q.TA'/Q.TY
1	DW3070010	BASKET GUIDE 1300	2
2	DW3006090	OMEGA FOR REDUCER	1
3	DW3070178	STAND REINFORCEMENT	1
4	DW3071266	FOOT	4
5	DW3070190/C	"UL" LOWER DOOR PANEL 1300	1
6	DW3070203	REAR SIDE COVER L=700 (1300)	1
7	DW3070365	EXTERNAL SIDE PANEL	1
8	ND	LOWER DOOR INSULATION 1300	1
9	ND	BACK SIDE COVER INSULATION 1300	1
10	DW3009121	BIADHESIVE EXPANDED POLYETHYLENE	3
11	DW3019071	PUMP SUCTION FILTER	1
12	DW80208	Ø95x75x3 GASKET	1
13	ND	BACK SIDE COVER INSULATION	2
14	DW3070304	LEFT SIDE PANEL	1
15	DW3070157	RIGHT SIDE PANEL	1
16	DW3009729	EXTERNAL SIDE PANEL (200mm)	1
17	DW3070319	EXTERNAL SIDE PANEL (250mm)	1
18	DW----	----	--
19	DW3070140/A	WASH ZONE FILTER WITH HOLE	1
20	DW3070008	FILTER ASSEMBLY	1
21	DW3070006/A	WASH-FILTER DRAWER ASS.	1
22	DW500603	WATER DRAIN SCRAP TRAY	1
23	DW80106	S/S AIR TRAP	1
24	DW75311	HEATING ELEMENT COVER	1
25	DW16045	FIXING BRACKET	1
26	DW3071244	14 Kw 230V3"UL" HEATING ELEMENT	1
27	DW13015	ORING 160 (6225)	1
28	DW3071256	"UL" PRESSURE SWITCH (250-40) [W1]	1(WASH)
28	DW3071255	"UL" PRESSURE SWITCH (190-60) [RR]	1(RINSE)
29	DW3009363	PRESSURE SWITCH SUPPORT	1
30	DW3070008/A	REAR FILTER WASH	1
31	DW540004	PIPE COUPLING	1
32	DW3071096/U	PRERINS-PUMP (UL) 0,27HP 208/240V 60HZ	1
33	DW3000318	SUPPORT PUMP	1
34	DW3070202	REAR SIDE COVER L=600 (1300)	1
35	DW3003981	OVERFLOW-PIPE	1
36	DW13021	DEM 40 O-Ring	1
37	DW3000316	FILTER WITH BASKET	1
38	DW500601	FERRULE WITH FILTER	1



ECONOMIZZATORE



ECONOMIZER



ECONOMISEUR

DWG-5xxx
Rev.00 - 05/2017

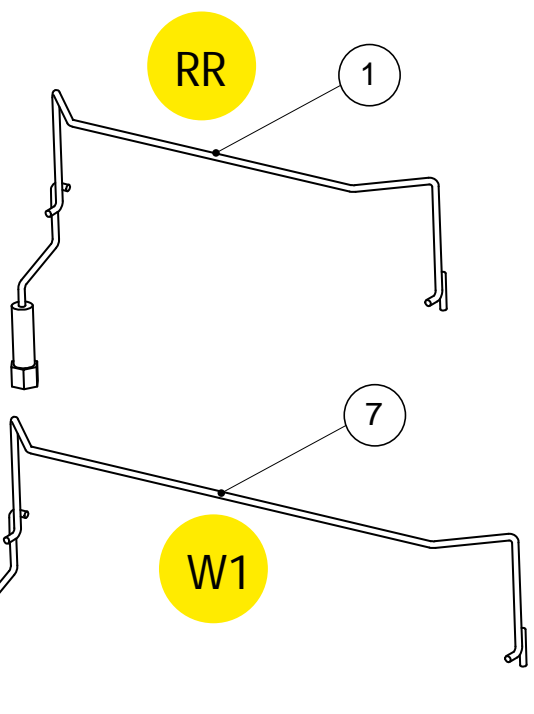
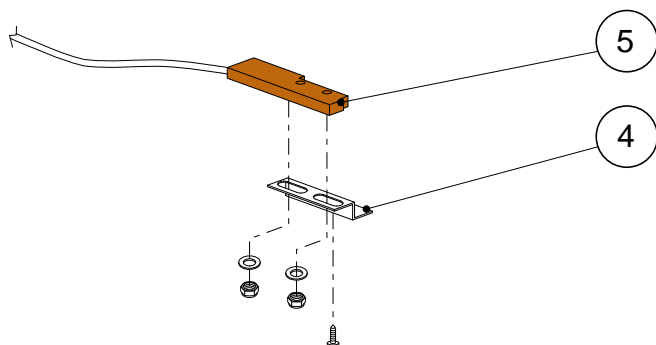
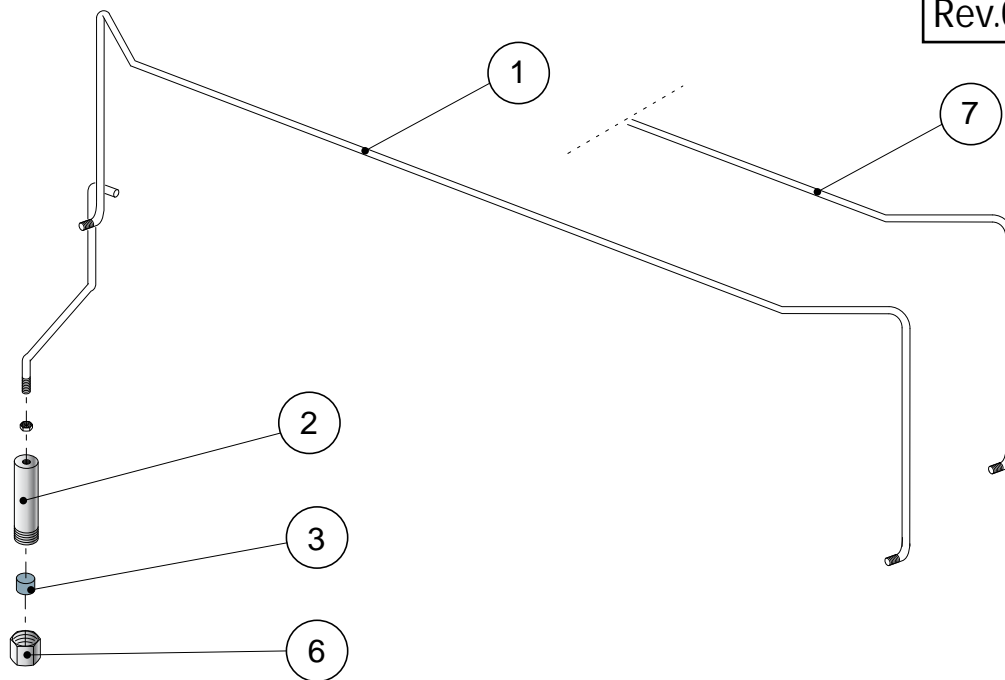

ITEM / ID	(IT)	(EN)	(FR)
SG	PARASPRUZZI	SPLASH ZONE	SAS
AS	PREL. AUTOMATICO	PRE-WASH SHOWER	PRELAVAGE AUT.+TIROR
PW	PRELAVAGGIO	PRE-WASH	PRELAVAGE
W2	2°LAVAGGIO	SECOND WASH	2°LAVAGE
W1	1°LAVAGGIO	FIRST WASH	1°LAVAGE
RR	RISCIACQUO POT.	POWER RINSE	RINÇAGE PLUS
CP	PANNELLO COM.	CONTROL PANELL	PANNEAU DE CONTRÔLE
D	ASCIUGATURA	DRYER	SECHAGE

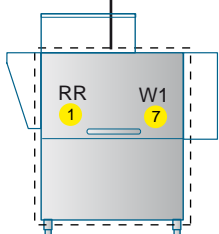



ITEM / ID	CODICE / P-code	DESCRIPTION (EN)	Q.TA'/Q.TY
1	DW3071018	RIGHT RACK SWITCH ARM (mod.1300 W1)	1
1	DW3071019	LEFT RACK SWITCH ARM (mod.1300 W1)	1
2	DW3003058	MAGNETE HOLDER	1
3	DW3003113	MAGNET	1
4	DW3009112	ECONOMIZER MICROSWITCH SUPPORT	1
5	DW3003112	ECONOMIZER MICROSWITCH	1
6	DW3004184	PLUG	1
7	DW3071016	RIGHT RACK SWITCH ARM (mod.1300 RR)	1
7	DW3071017	LEFT RACK SWITCH ARM (mod.1300 RR)	1



MOTORIDUTTORE



MOTORGEAR



MOTORÉDUCTEUR

ITEM / ID	(IT)	(EN)	(FR)
SG	PARASPRUZZI	SPLASH ZONE	SAS
AS	PREL.AUTOMATICO	PRE-WASH SHOWER	PRELAVAGE AUT.+TIROR
PW	PRELAVAGGIO	PRE-WASH	PRÉLAVAGE
W2	2°LAVAGGIO	SECOND WASH	2°LAVAGE
W1	1°LAVAGGIO	FIRST WASH	1°LAVAGE
RR	RISCIACO. POT.	POWER RINSE	RINÇAGE PLUS
CP	PANNELLO COM.	CONTROL PANELL	PANNEAU DE CONTRÔLE
D	ASCIUGATURA	DRYER	SECHAGE

DWG-XXXX
Rev.00 - 05/2017

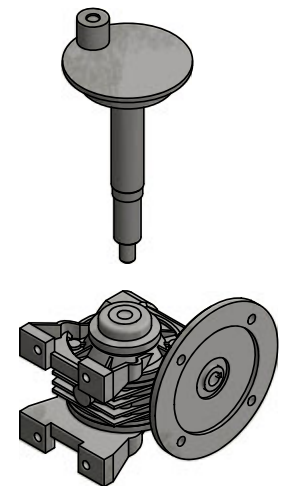
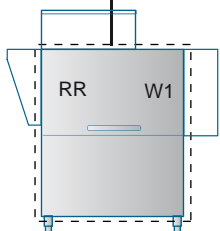
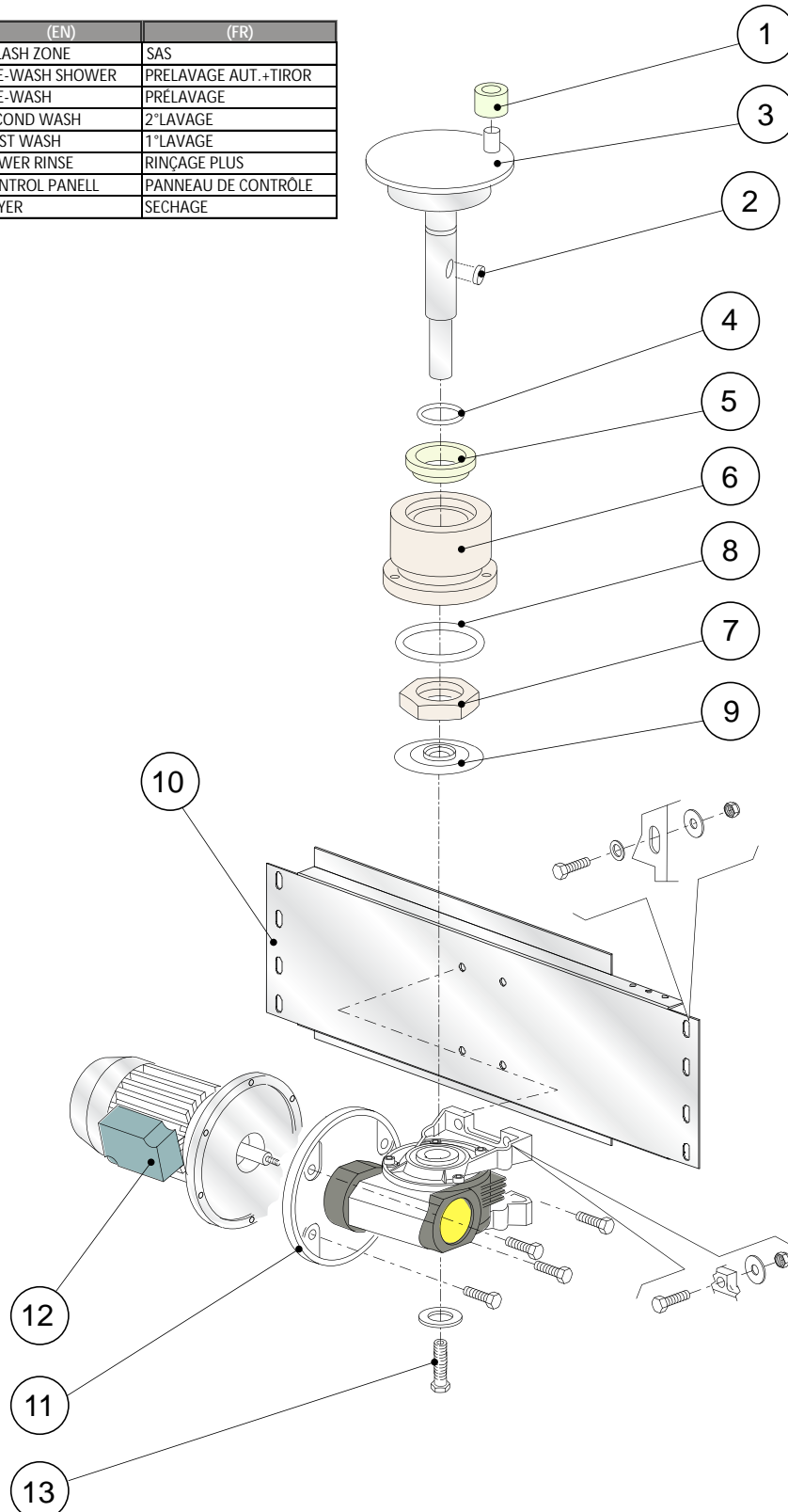



ITEM / ID	CODICE / P-code	DESCRIPTION (EN)	Q.TA'/Q.TY
1	DW3003012	CONVEYOR ROLLER	1
2	DW2001046	KEY	1
3	DW3003116	CRANK SHAFT	1
4	DW13023	O-RING131 (4093)	1
5	DW13024	OIL SPLASH GUARD DEM 40 TC 30x42x7 WITH SPRING	1
6	DW3004131	COUPLING PART DERIE	1
7	DW3004183	NUT	1
8	DW13015	O-RING 160 (6225)	1
9	DW3004161	PROTECTION DISK	1
10	DW3009060	MOTORGear SUPPORT	1
11	DW3000218	GEAR RIGHT 1:28 (60Hz)	1
11	DW3000219	GEAR LEFT 1:28 (60Hz)	1
12	DW3000110/U	CONVEYOR MOTOR 6/8P 208/240V 3 60Hz ("UL")	1
13	DW11165	SCREW	1

DWG-XXXX
Rev.00 - 05/2017

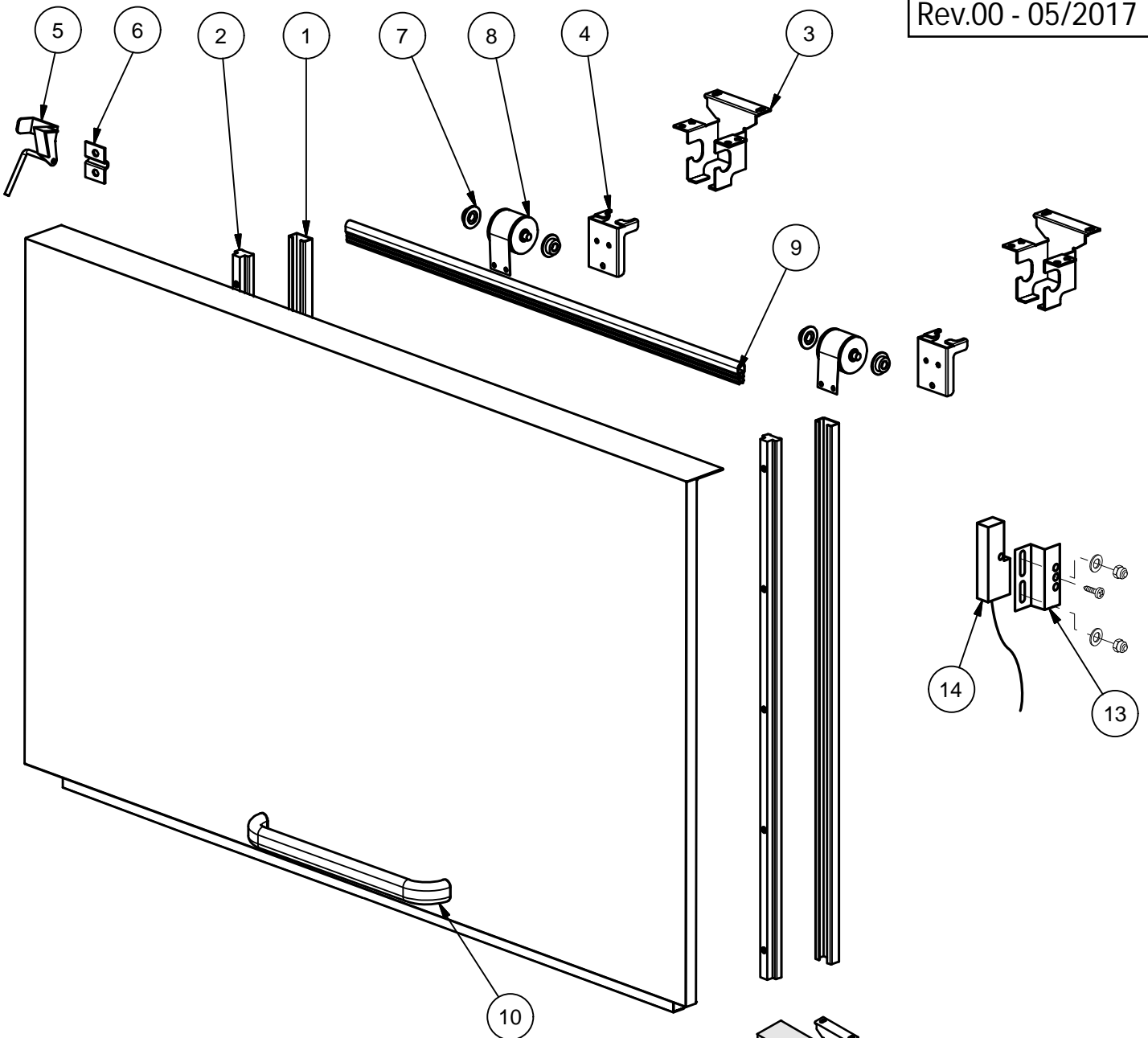

ITEM / ID	(IT)	(EN)	(FR)
SG	PARASPRUZZI	SPLASH ZONE	SAS
AS	PREL.AUTOMATICO	PRE-WASH SHOWER	PRELAVAGE AUT.+TIROR
PW	PRELAVAGGIO	PRE-WASH	PRELAVAGE
W2	2°LAVAGGIO	SECOND WASH	2°LAVAGE
W1	1°LAVAGGIO	FIRST WASH	1°LAVAGE
RR	RISCIACQUO POT.	POWER RINSE	RINÇAGE PLUS
CP	PANNELLO COM.	CONTROL PANELL	PANNEAU DE CONTRÔLE
D	ASCIUGATURA	DRYER	SECHAGE

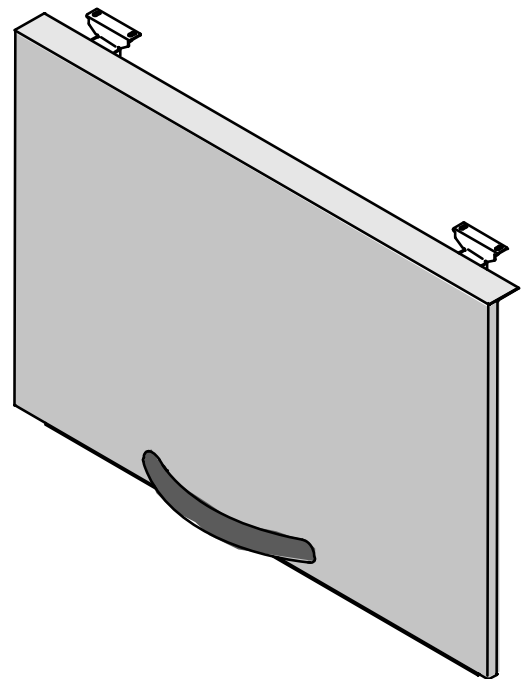
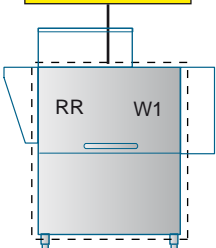



ITEM / ID	CODICE / P-code	DESCRIPTION (EN)	Q.TA'/Q.TY
1	DW3009033	SLIDEWAYS	2
2	DW3070028	DOOR ASSEMBLY 1300	1
3	DW3070197	SPRING SUPPORT L38	2
4	DW3070134	DOOR STOP	2
5	DW3000315	SAFETY DOOR HOOK	1
6	DW3000314	SAFETY DOOR BRACKET	1
7	DW3004012	SPRING HOLDER	4
8	DW3071120	DOOR SPRING MOD 1300	2
9	DW3071114	DOOR GASKET	1
10	DW22215	INOX HANDLE	1
11	DW22261	INOX HANDLE Ø 30	1
12	DW22260	INOX HANDLE 40x20	1
13	DW3009112	MICROSWITCH SUPPORT	1
14	DW3003112	DOOR MICROSWITCH	1

ITEM / ID	(IT)	(EN)	(FR)
SG	PARASPRUZZI	SPLASH ZONE	SAS
AS	PREL.AUTOMATICO	PRE-WASH SHOWER	PRÉLAVAGE AUT.+TIROR
PW	PRELAVAGGIO	PRE-WASH	PRÉLAVAGE
W2	2°LAVAGGIO	SECOND WASH	2°LAVAGE
W1	1°LAVAGGIO	FIRST WASH	1°LAVAGE
RR	DOBPIO RISCIAQ.	DOUBLE RINSE	DOUBLE RINÇAGE
CP	PANNELLO COM.	CONTROL PANELL	PANNEAU DE CONTRÔLE
D	ASCIUGATURA	DRYER	SECHAGE

DWG-5xxxx
Rev.00 - 05/2017

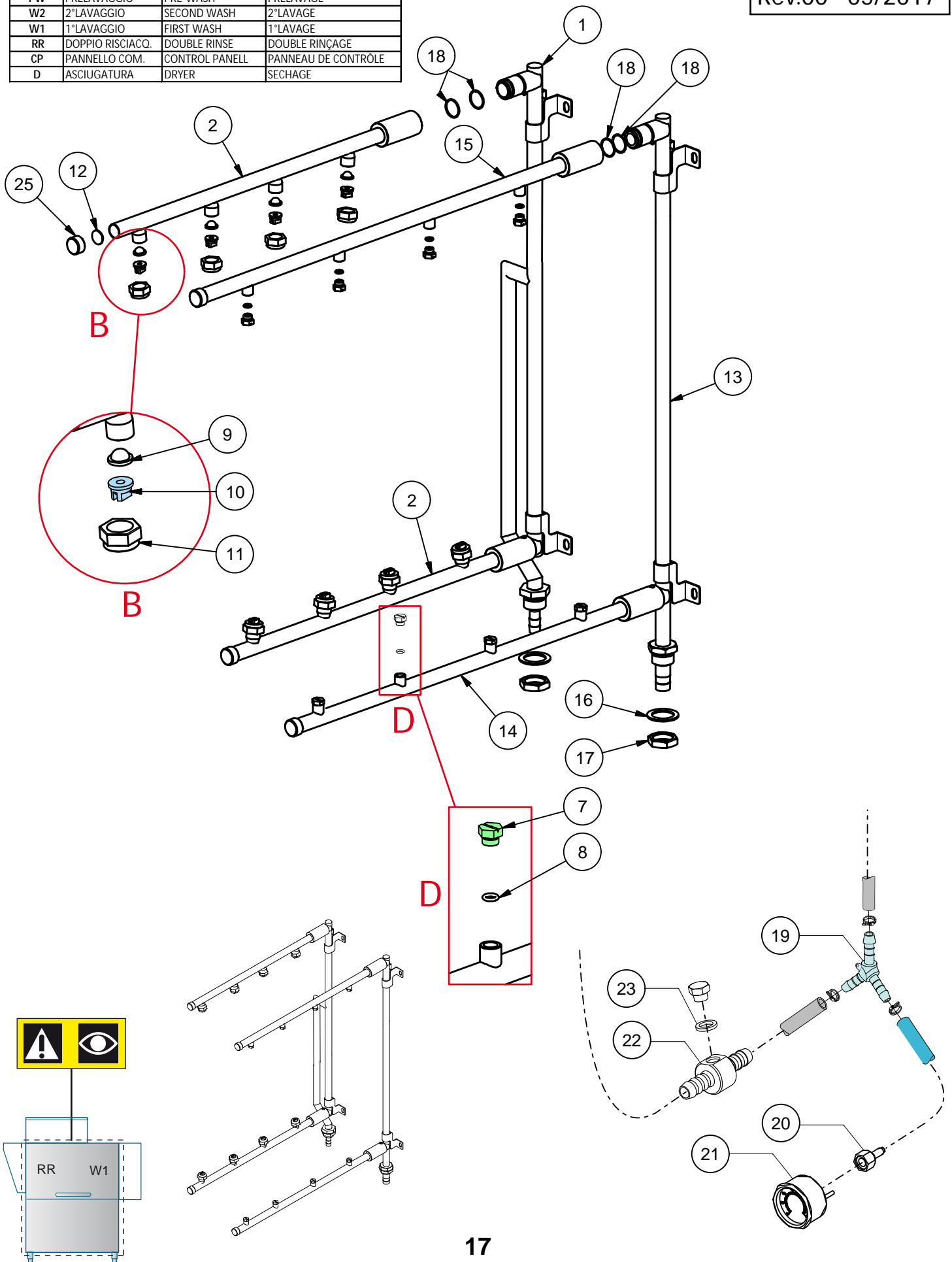



ITEM / ID	CODICE / P-code	DESCRIPTION (EN)	Q.TA'/Q.TY
1	DW3071058	RINSE RAMP ASSEMBLY	1
2	DW3071059	RINSE ARM ASSEMBLY	2
7	DW3071263	PRE RINSE NOZZLE 1/8 G (120° INOX)	8
8	DW13002	O-RING R6 NBR	8
9	DW2200117	FILTER	8
10	DW3071262	S/S RINSE NOZZLE (110° INOX)	8
11	DW2200116	S/S NUT 3/8 F	8
12	DW2002051	EPDM RINSE PLUG GASKET D.17,5X1,5	4
13	DW3071057	PRE RINSE RAMP ASSEMBLY	1
14	DW3071060	LOWER PRE RINSE ARM ASSEMBLY	1
15	DW3071060	UPPER PRE RINSE ARM ASSEMBLY	1
16	DW13326	GASKET D.38X27X2	2
17	DW2200103	BRASS NUT 3/4 ES.32X8	2
18	DW13025	OR 2081 NBR GASKET	8
19	DW540104	3 WAY CONNECTION Ø 12-10-10	1
20	DW10798/B	M10x1 RUBBER HOLDER	1
21	DW10500008	MANOMETER	1
22	DW3003906	"T" CONNECTION	1
23	DW13309	Ø 10x14x1,5 GASKET	1
25	DW2002054	PLUG M18X1 D21X9	4



RAMPA DI LAVAGGIO



WASH RAMP



RAMPE DE LAVAGE

DWG-5xxx
Rev.00 - 05/2017

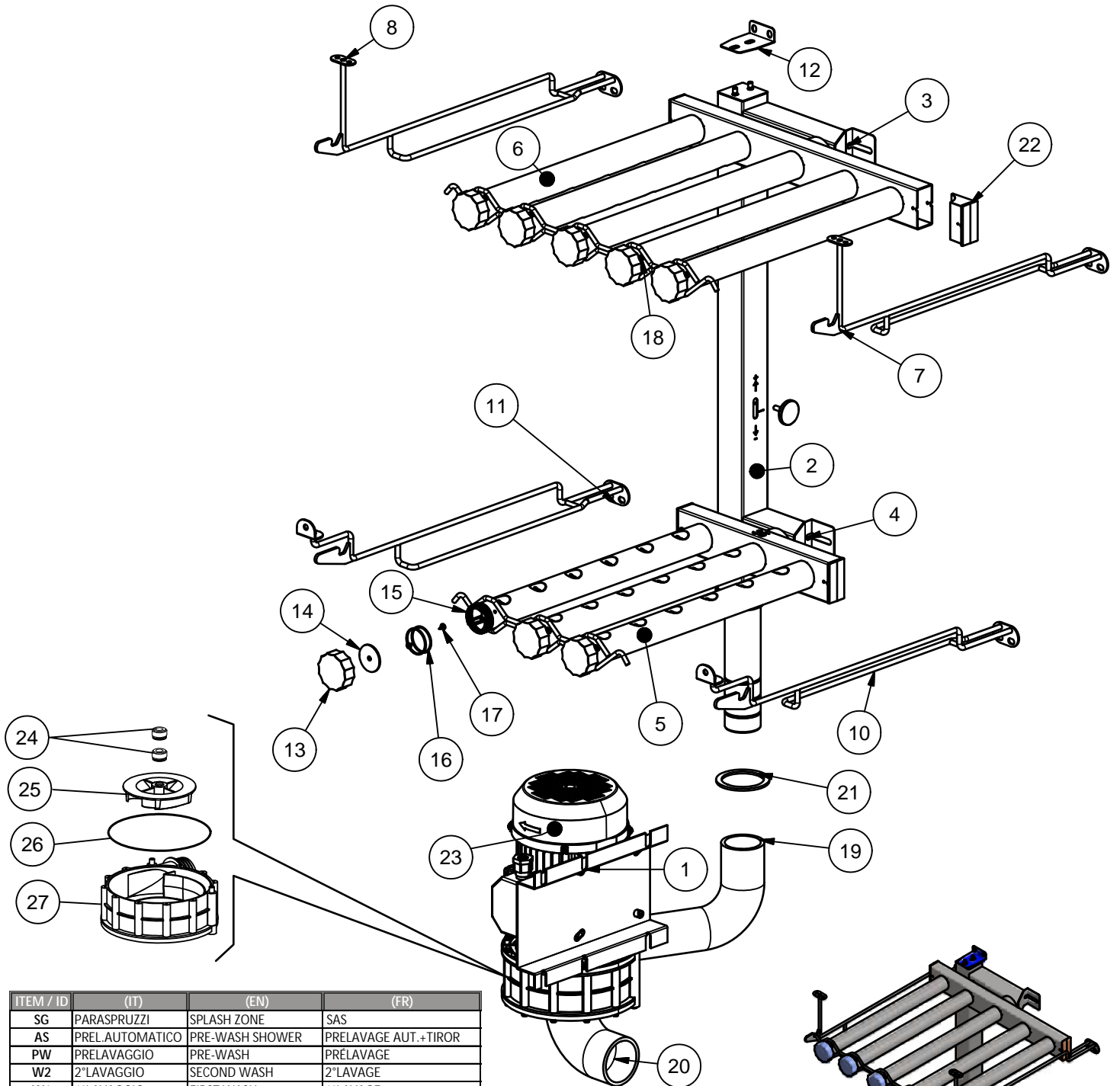

ITEM / ID	(IT)	(EN)	(FR)
SG	PARASPRUZZI	SPLASH ZONE	SAS
AS	PREL.AUTOMATICO	PRE-WASH SHOWER	PRELAVAGE AUT.+TIROR
PW	PRELAVAGGIO	PRE-WASH	PRELAVAGE
W2	2°LAVAGGIO	SECOND WASH	2°LAVAGE
W1	1°LAVAGGIO	FIRST WASH	1°LAVAGE
RR	RISCIACQUO POT.	POWER RINSE	RINÇAGE PLUS
CP	PANNELLO COM.	CONTROL PANELL	PANNEAU DE CONTRÔLE
D	ASCIUGATURA	DRYER	SECHAGE

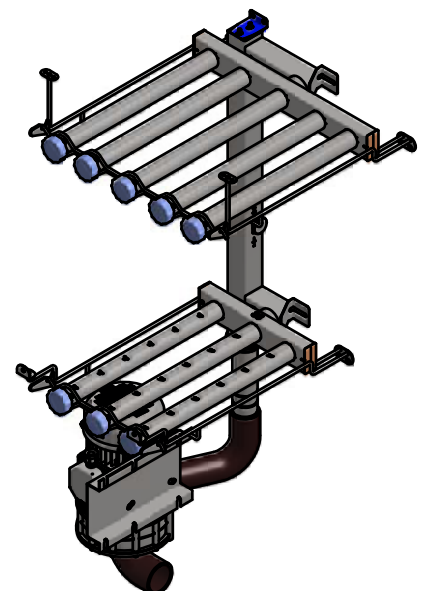
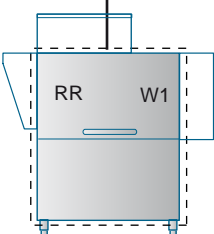



ITEM / ID	CODICE / P-code	DESCRIPTION (EN)	Q.TA'/Q.TY
1	DW3009148	WASH PUMP SUPPORT	1
2	DW3071050	WASH RAMP	1
3	DW3071047	RACK SIDE CONNECTION 5 (5+3)	1
4	DW3071043	RACK SIDE CONNECTION 3 (3+2 / 5+3)	1
5	DW3071035	RIGHT RACK 3 (5+3)	1
5	DW3071036	LEFT RACK 3 (5+3)	1
6	DW3071037	RACK 5 (5+3)	1
7	DW3071024	RIGHT UPPER GUIDE	1
8	DW3071025	LEFT UPPER GUIDE	1
22	DW3071027	RECTANGULAR PLUG FOR RAMP	4
10	DW3071022	RIGHT LOWER GUIDE	1
11	DW3071023	LEFT LOWER GUIDE	1
12	DW3070247	RAMP FIXING BRACKET	1
13	DW80304	PLUG FOR GREY TERMINAL NOZZLE	1
14	DW80305	PLUG SEAL	1
15	DW3071026	RAMP PLUG FERRULE	1
16	DW3071117	OR GASKET 2137	2
17	DW11004	4x10 SPAX SCREW	4
18	ND	PLUG + FERRULE	7
19	DW3004025	L SHAPE COUPLING 50/50	1
20	DW3002020	EPDM ELBOW COUPLING	1
21	DW10200173/A	75X58X3 GASKET	1
22	DW3071027	RECTANGULAR PLUG FOR RAMP	4
23	DW88106/U	PUMP HP 2.7 208/240V 3 60Hz ("UL")	1
24	DW15080/F	ROTATING SEALS	2
25	DW88232	HP 2,7 PUMP ROTOR ("UL")	1
26	DW88231	O-RING 1225 ("UL")	1
27	DW88230	SCROLL ("UL")	1

DWG-XXXX
Rev.00 - 05/2017

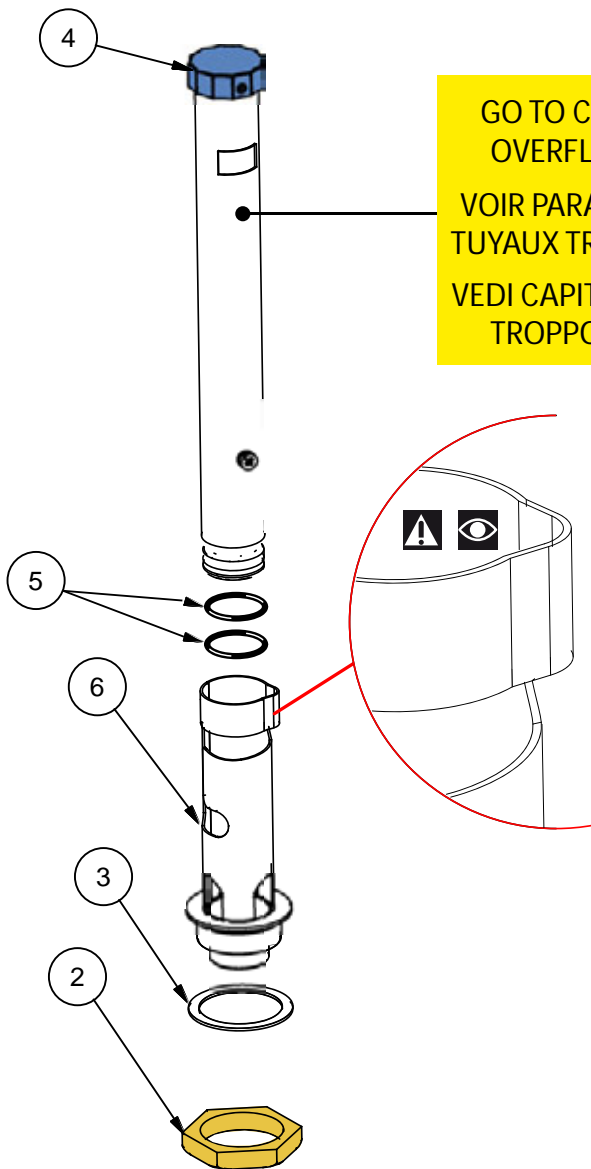

GO TO CHAPTER
 OVERFLOEPIPE
 VOIR PARAGRAPH
 TUYAUX TROP-PLEIN
 VEDI CAPITOLO TUBI
 TROPPO PIENO

ITEM / ID	(IT)	(EN)	(FR)
SG	PARASPRUZZI	SPLASH ZONE	SAS
AS	PREL. AUTOMATICO	PRE-WASH SHOWER	PRELAVAGE AUT.+TIROR
PW	PRELAVAGGIO	PRE-WASH	PRELAVAGE
W2	2°LAVAGGIO	SECOND WASH	2°LAVAGE
W1	1°LAVAGGIO	FIRST WASH	1°LAVAGE
RR	RISCIACQUO POT.	POWER RINSE	RINÇAGE PLUS
CP	PANNELLO COM.	CONTROL PANELL	PANNEAU DE CONTRÔLE
D	ASCIUGATURA	DRYER	SECHAGE

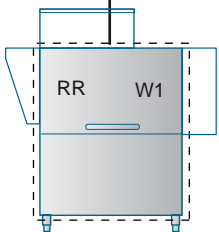



ITEM / ID	CODICE / P-code	DESCRIPTION (EN)	O.TA/O.TY
2	DW10600012	FLAT NUT	1
3	DW10200173	O-RING 75X58X2	1
4	DW88105	ARM PLUG	1
5	DW13019	O-RING GASKET 140 NBR	2
6	DW3071084	OVERFLOW DIVICE SUPPORT	1



B3 = Pre-rinsing Boiler(UL)

DWG-55xxx
Rev.00 - 05/2017

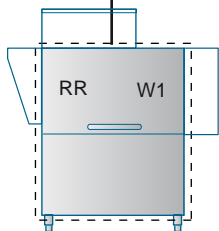
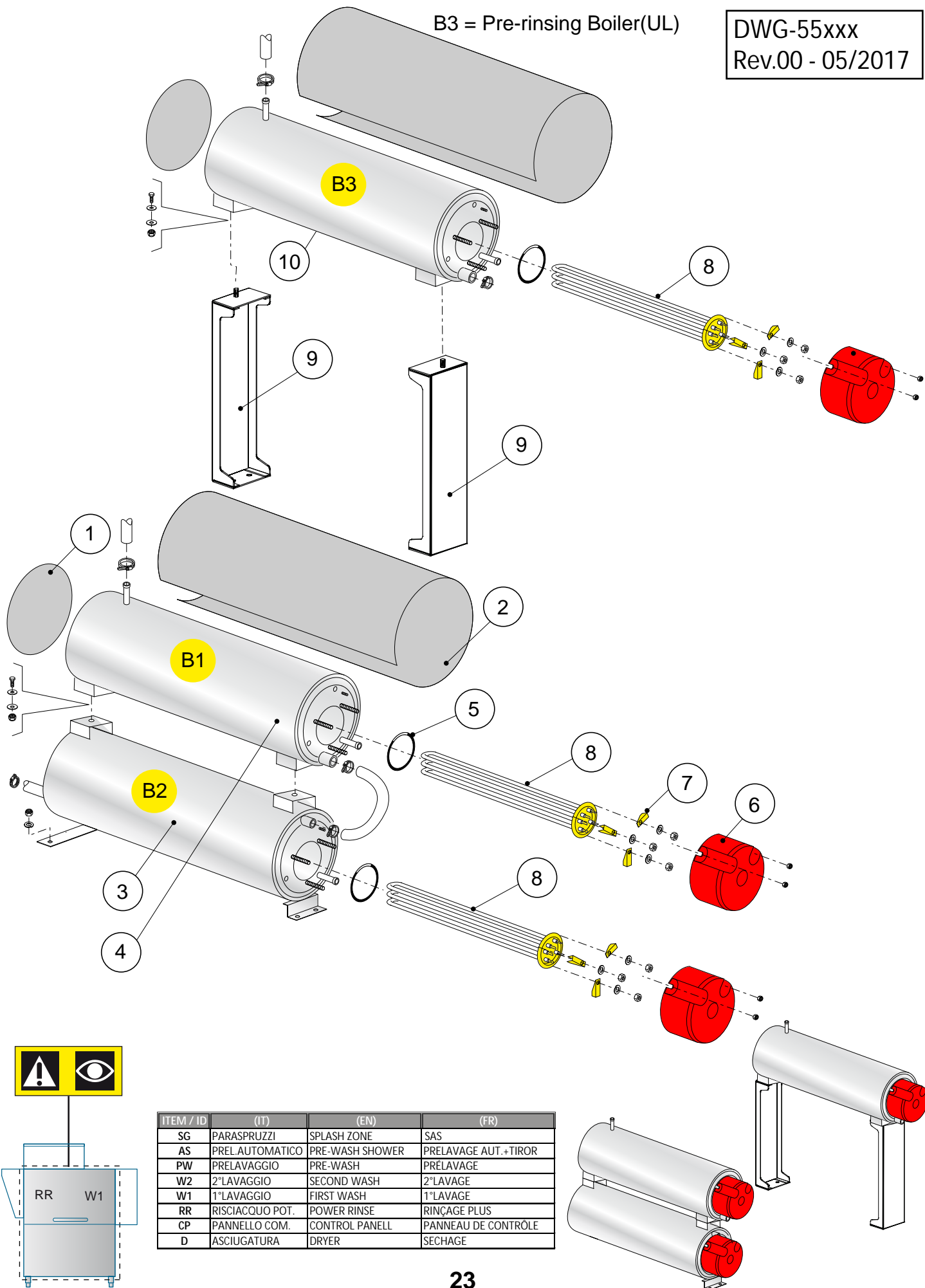

ITEM / ID	(IT)	(EN)	(FR)
SG	PARASPRUZZI	SPLASH ZONE	SAS
AS	PREL.AUTOMATICO	PRE-WASH SHOWER	PRELAVAGE AUT.+TIROR
PW	PRELAVAGGIO	PRE-WASH	PRELAVAGE
W2	2°LAVAGGIO	SECOND WASH	2°LAVAGE
W1	1°LAVAGGIO	FIRST WASH	1°LAVAGE
RR	RISCIACQUO POT.	POWER RINSE	RINÇAGE PLUS
CP	PANNELLO COM.	CONTROL PANELL	PANNEAU DE CONTRÔLE
D	ASCIUGATURA	DRYER	SECHAGE



ITEM / ID	CODICE / P-code	DESCRIPTION (EN)	Q.TA'/Q.TY
1	DW75205	BOTTOM BOILER INSULATING	2
2	DW30002030	BOILER INSULATING	2
3	DW3007012	INFERIOR BOILER	1
4	DW3007013	UPPER BOILER	1
5	DW13015	O-RING 160 (6225)	3
6	DW75311	HEATING ELEMENT COVER	3
7	DW16045	HEATING ELEMENT SUPPORT Ø6.3	9
8	DW15197	HEATING ELEMENT 9 kW 230V ("UL")	3
9	DW3070366	BOILER SUPPORT	2
10	DW3071267	UPPER PRE-RINSING BOILER ("UL")	1

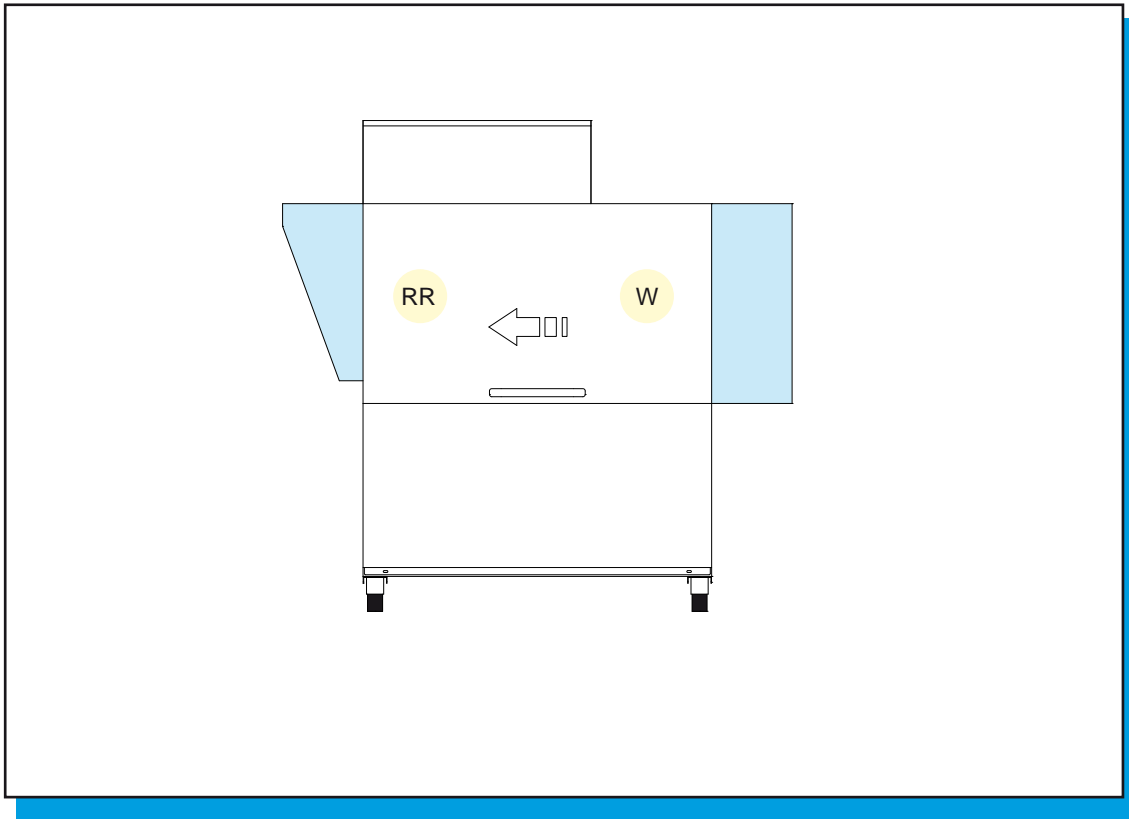

SPLASH ZONE

ITEM / ID	(IT)	(EN)	(FR)
SG	PARASPRUZZI	SPLASH ZONE	SAS
AS	PREL.AUTOMATICO	PRE-WASH SHOWER	PRELAVAGE AUT.+TIROR
PW	PRELAVAGGIO	PRE-WASH	PRELAVAGE
W2	2°LAVAGGIO	SECOND WASH	2°LAVAGE
W1	1°LAVAGGIO	FIRST WASH	1°LAVAGE
RR	RISCIACQUO POT.	POWER RINSE	RINÇAGE PLUS
CP	PANNELLO COM.	CONTROL PANELL	PANNEAU DE CONTRÔLE
D	ASCIUGATURA	DRYER	SECHAGE

DWG-XXXX
Rev.00 - 05/2017

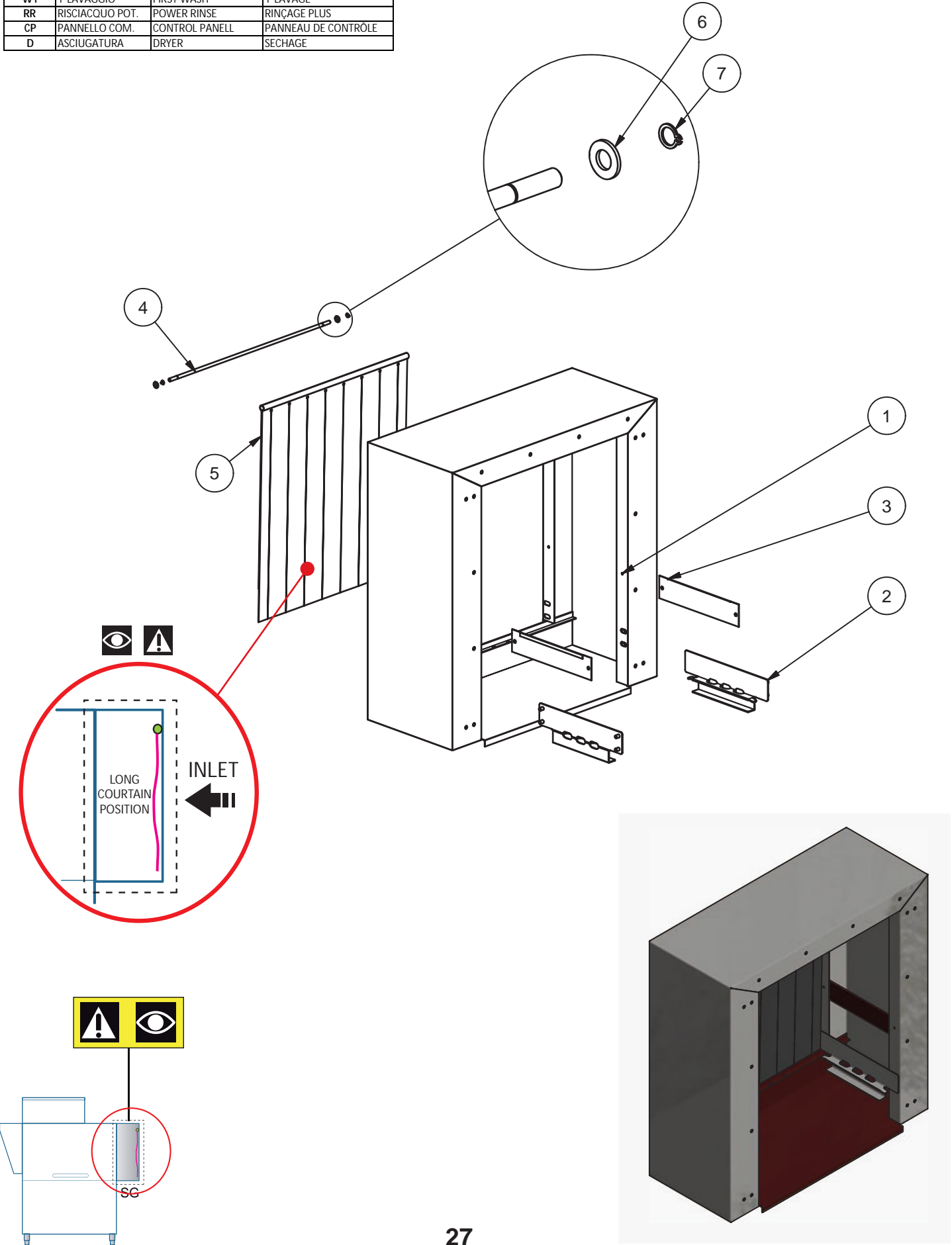



ITEM / ID	CODICE / P-code	DESCRIPTION (EN)	Q.TA'/Q.TY
1	DW3073035	SPLASH ZONE	1
2	DW3070011	SLIDE BASKET	2
3	DW3070161	BULKHEAD CURTAIN	2
4	DW3071069	CURTAIN ROD	1
5	DW3071070	CURTAIN	1
6	DW11185	INOX WASHER 8X16 DIN125	2
7	DW11815	INOX SEEGER Ø8 UNI7435	2



PARASPRUZZI L=300mm



SPLASH ZONE L=300mm



GARDE-BOUE L=300mm

ITEM / ID	(IT)	(EN)	(FR)
SG	PARASPRUZZI	SPLASH ZONE	SAS
AS	PREL.AUTOMATICO	PRE-WASH SHOWER	PRELAVAGE AUT.+TIROR
PW	PRELAVAGGIO	PRE-WASH	PRELAVAGE
W2	2°LAVAGGIO	SECOND WASH	2°LAVAGE
W1	1°LAVAGGIO	FIRST WASH	1°LAVAGE
RR	RISCIACQUO POT.	POWER RINSE	RINÇAGE PLUS
CP	PANNELLO COM.	CONTROL PANELL	PANNEAU DE CONTRÔLE
D	ASCIUGATURA	DRYER	SECHAGE

DWG-XXXX
Rev.00 - 05/2017

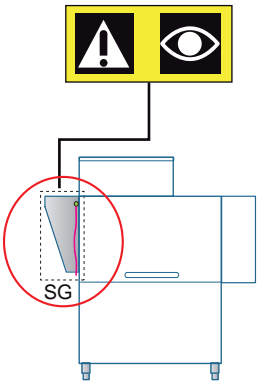
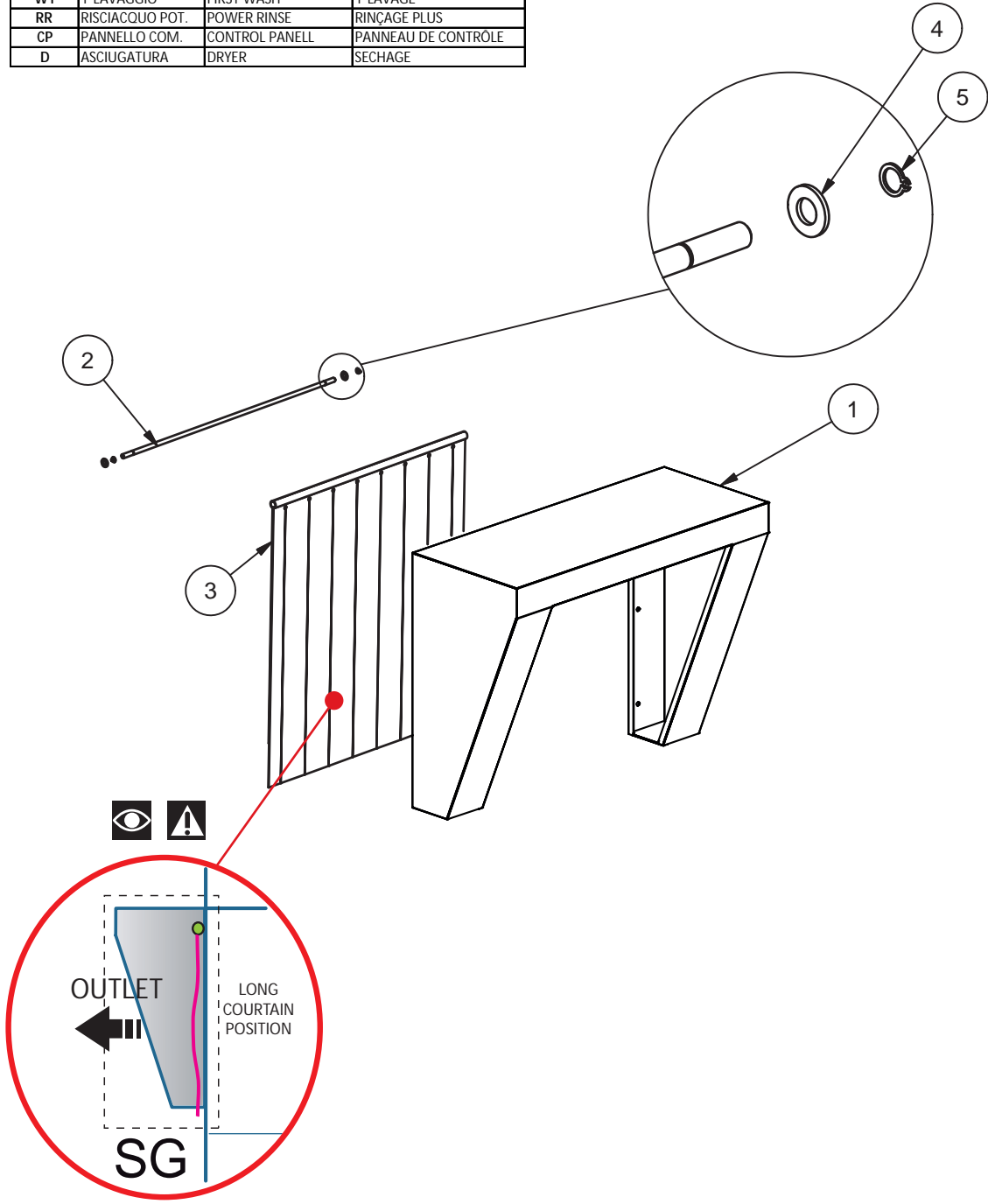



ITEM / ID	CODICE / P-code	DESCRIPTION (EN)	Q.TA'/Q.TY
1	DW3073362	SPLASH ZONE	1
2	DW3071069	CURTAIN ROD	1
3	DW3071070	CURTAIN	1
4	DW11185	INOX WASHER 8X16 DIN125	2
5	DW11815	INOX SEEGER Ø8 UNI7435	2

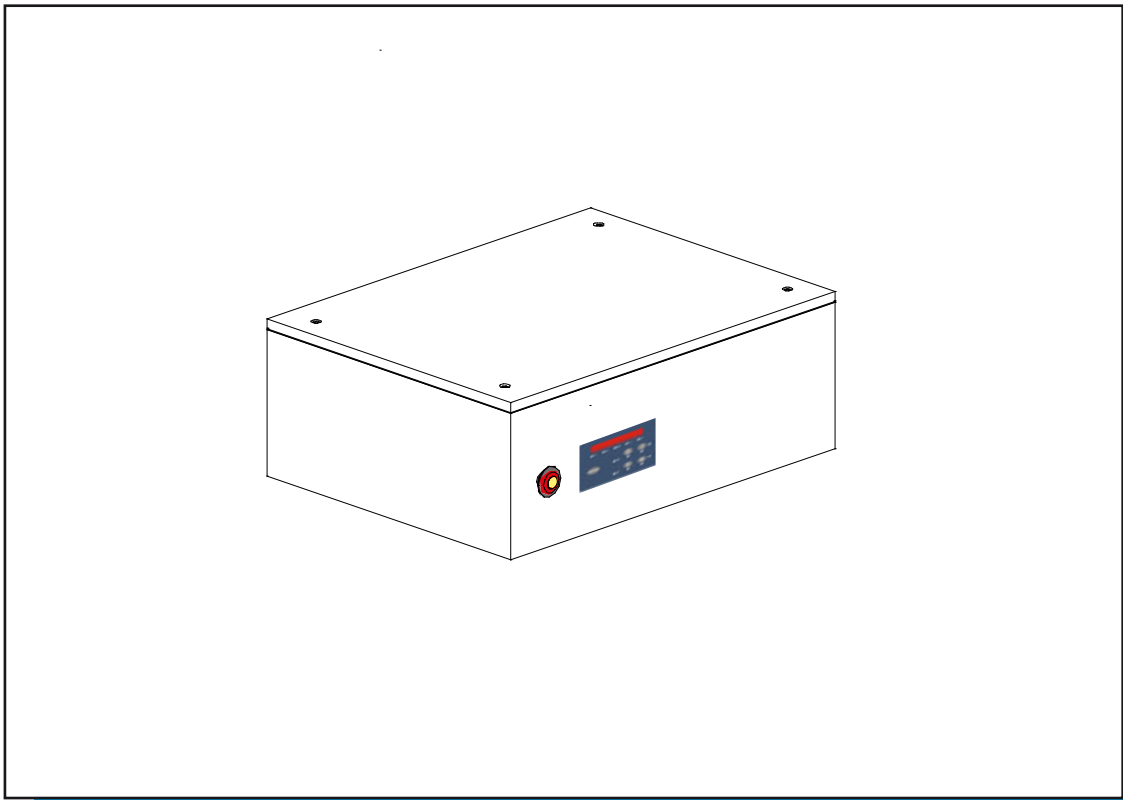

———— **CONTROL PANEL**



ITEM / ID	(IT)	(EN)	(FR)
SG	PARASPRUZZI	SPLASH ZONE	SAS
AS	PREL.AUTOMATICO	PRE-WASH SHOWER	PRELAVAGE AUT.+TIROR
PW	PRELAVAGGIO	PRE-WASH	PRELAVAGE
W2	2°LAVAGGIO	SECOND WASH	2°LAVAGE
W1	1°LAVAGGIO	FIRST WASH	1°LAVAGE
RR	RISCIACQUO POT.	POWER RINSE	RINÇAGE PLUS
CP	PANNELLO COM.	CONTROL PANELL	PANNEAU DE CONTRÔLE
D	ASCIUGATURA	DRYER	SECHAGE

01_xxxx
Rev.00 - 05/2017

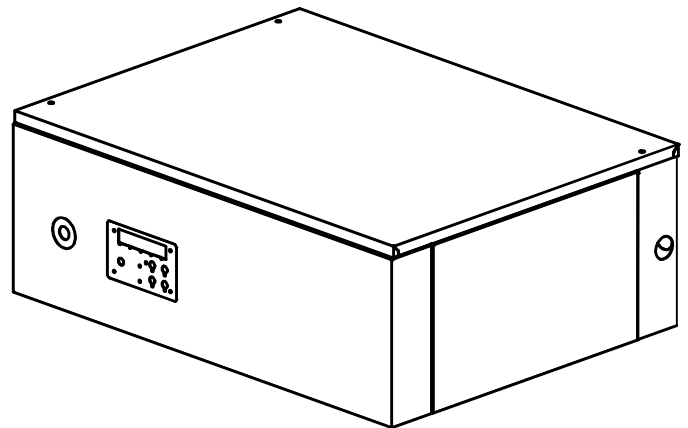
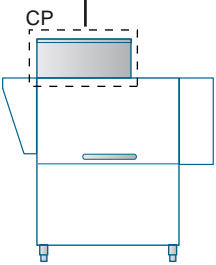
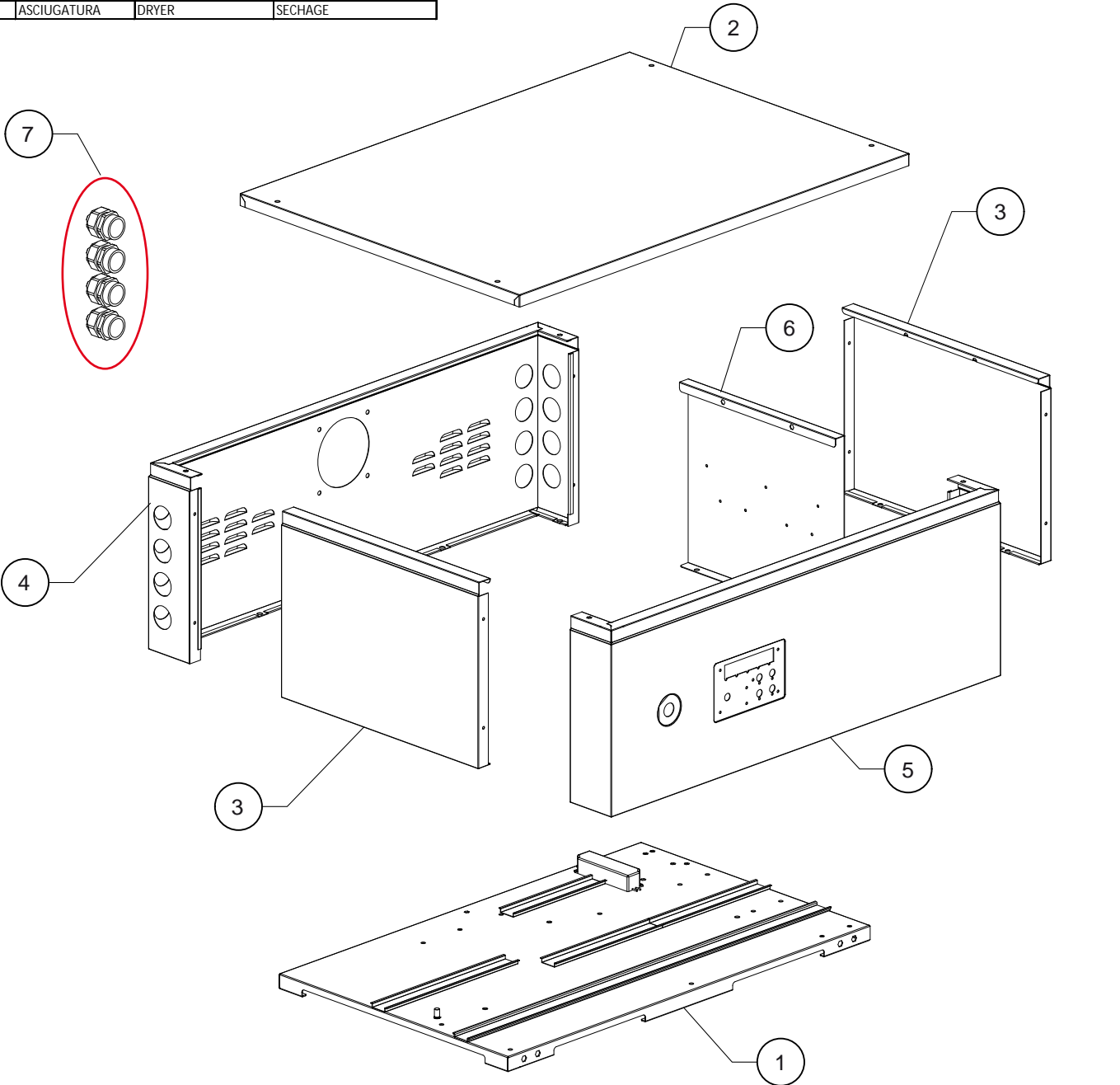

 PANNELLO COMANDI
  CONTROL PANEL
  PANNEAU DE CÔNT.

ITEM / ID	(IT)	(EN)	(FR)
SG	PARASPRUZZI	SPLASH ZONE	SAS
AS	PREL.AUTOMATICO	PRE-WASH SHOWER	PRELAVAGE AUT.+TIROR
PW	PRELAVAGGIO	PRE-WASH	PRELAVAGE
W2	2°LAVAGGIO	SECOND WASH	2°LAVAGE
W1	1°LAVAGGIO	FIRST WASH	1°LAVAGE
RR	RISCIACQUO POT.	POWER RINSE	RINÇAGE PLUS
CP	PANNELLO COM.	CONTROL PANELL	PANNEAU DE CONTRÔLE
D	ASCIUGATURA	DRYER	SECHAGE

01_XXXX
Rev.00 - 05/2017

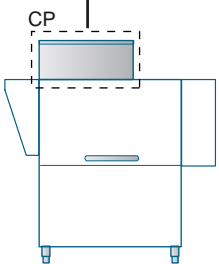
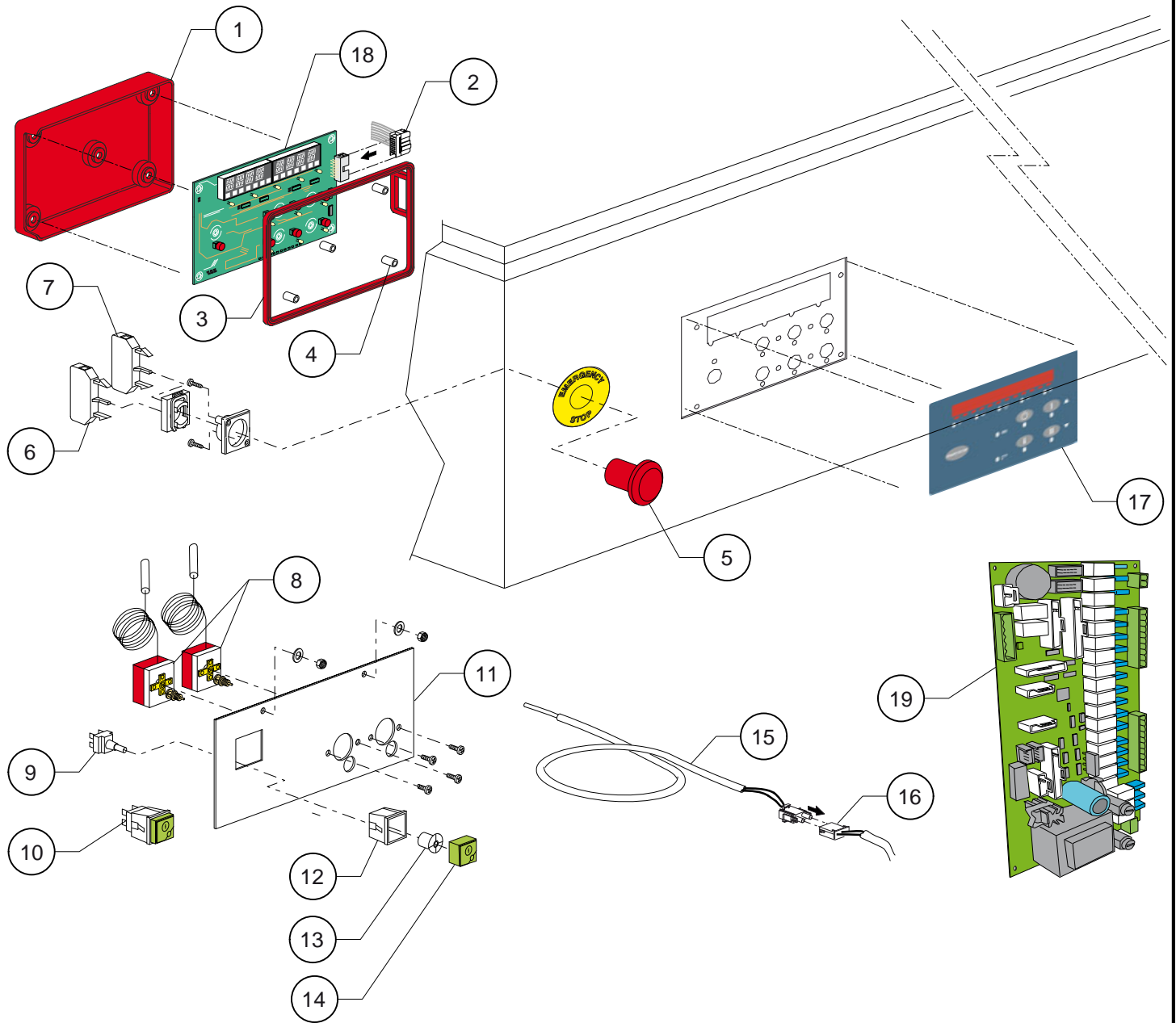



01_XXXX
Rev.00 - 05/2017

FRONT MACHINE

REAR MACHINE

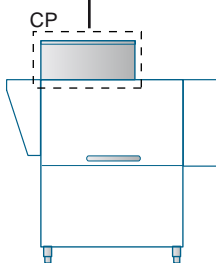
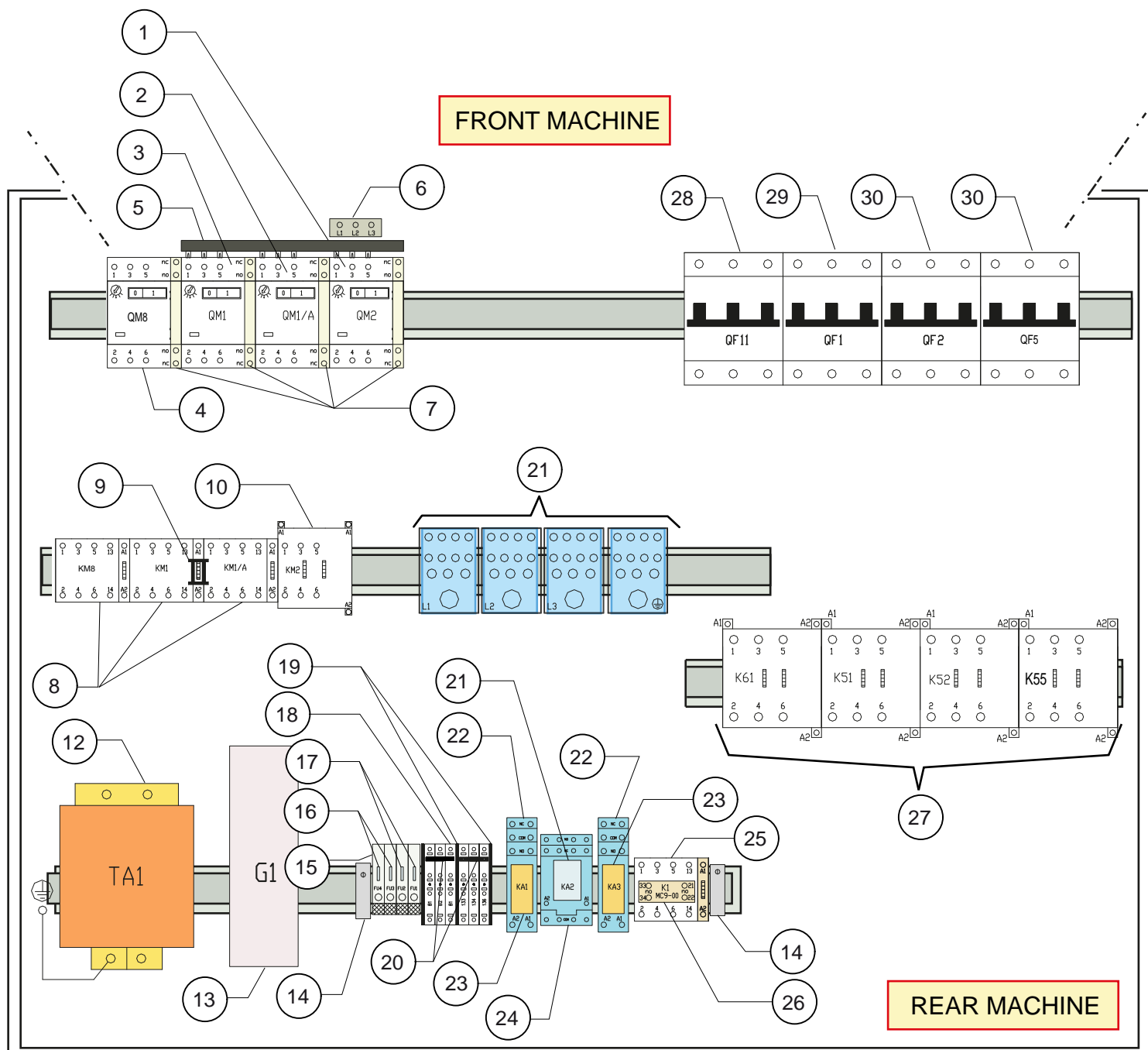

ITEM / ID	(IT)	(EN)	(FR)
SG	PARASPRUZZI	SPLASH ZONE	SAS
AS	PREL.AUTOMATICO	PRE-WASH SHOWER	PRELAVAGE AUT.+TIROR
PW	PRELAVAGGIO	PRE-WASH	PRELAVAGE
W2	2°LAVAGGIO	SECOND WASH	2°LAVAGE
W1	1°LAVAGGIO	FIRST WASH	1°LAVAGE
RR	RISCIAQUO POT.	POWER RINSE	RINÇAGE PLUS
CP	PANNELLO COM.	CONTROL PANELL	PANNEAU DE CONTRÔLE
D	ASCIUGATURA	DRYER	SECHAGE



ITEM / ID	CODICE / P-code	DESCRIZIONE (EN)	Q.TA'/Q.TY
1	DW2000395	MOTOR PROTECTOR 6,3 - 10A	---
2	DW2000389	MOTOR PROTECTOR 0,63 - 1A	---
3	DW2000390	MOTOR PROTECTOR 1 - 1,6A	---
4	DW2000393	MOTOR PROTECTOR 1,6 - 2,5A	---
5	DW3006100	4 POSITION ELECTRICAL CONTACTOR LMS25	---
6	DW3006087	CLAMP	---
7	DW3006080	AUXILIARY CONTACT LMS25	---
8	DW2000370	CONTACTOR MC9	---
9	DW3006153	MECHANICAL LOCK SAFETY	---
10	DW2000385	CONTACTOR BF20	---
11	DW3071248	UNIPOLAR DIVIDER 250 A ("UL")	---
12	DW3071246	TRANSFORMER ("UL") 200VA 0-230V 24V	---
13	DW3072237	POWER SUPPLY 20W 12V ("UL") NEC2	---
14	DW3006093	DIN GUIDE BACKSTOP	---
15	DW3006147	CLAMP SUPPORT FUSE 5x20 (5x25)	---
16	DW3071253	FUSE 5x20 10A ("UL")	---
17	DW3071254	FUSE 5x20 2A ("UL")	---
18	DW3071122	2,5mm ² (ZDK 2.5) DOUBLE TERMINAL CLAMP	---
19	DW3071123	CLAMP COVERING PLATE (ZAP/TW)	---
20	DW3071124	CONNECTING BRIDGE FOR TERMINAL BOARD	---
21	DW3071140	RELAY 4C/24V 10A	---
22	DW3006079	BASE FOR RELAY 2C/DEV 24V	---
23	DW3006078	RELAY 2C/DEV 24V	---
24	DW3071141	BASE FOR RELAY 4C/24V 10A	---
25	DW2000370	CONTACTOR MC9	---
26	DW3071252	AUXILIARY CONTACT 2NA	---
27	DW10300064	CONTACTOR BF32	---
28	DW3071249	TRIPOLAR AUTOMATIC FUSE 50A ("UL")	---
29	DW3071251	AUTOMATIC FUSE 25A ("UL")	---
30	DW3071250	AUTOMATIC FUSE 32A ("UL")	---

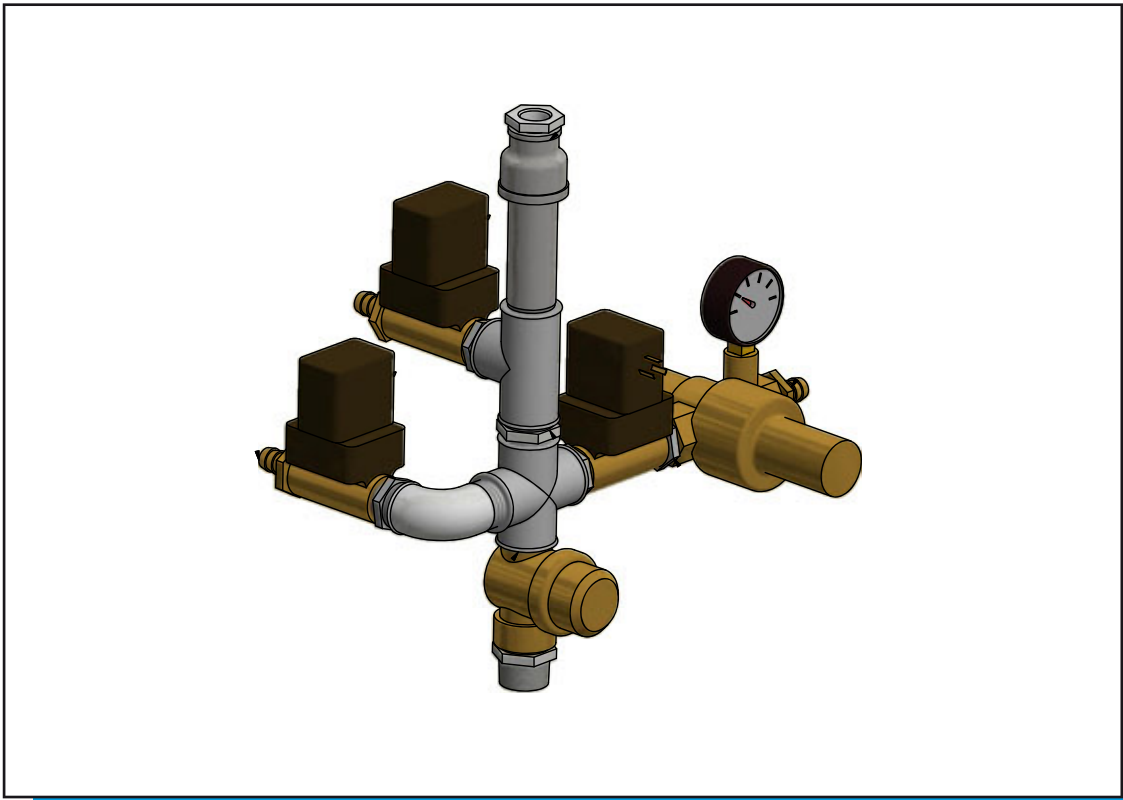

SOLENOID VALVES ASSEMBLY

DWG-XXXX
Rev.00 - 05/2017

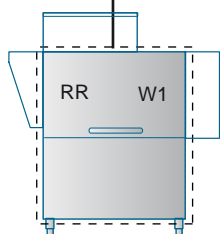
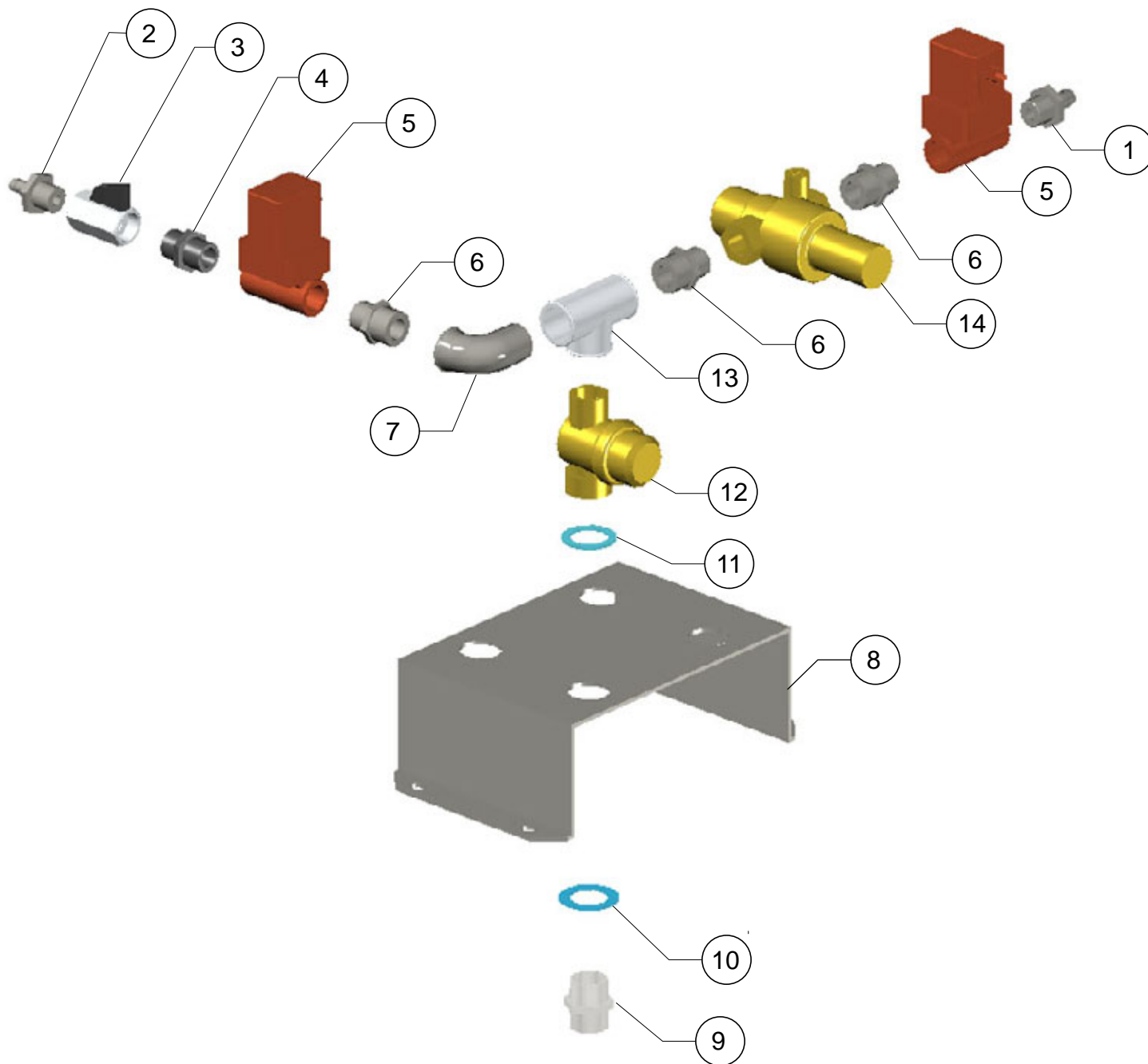

ITEM / ID	(IT)	(EN)	(FR)
SG	PARASPRUZZI	SPLASH ZONE	SAS
AS	PREL.AUTOMATICO	PRE-WASH SHOWER	PRELAVAGE AUT.+TIROR
PW	PRELAVAGGIO	PRE-WASH	PRÉLAVAGE
W2	2°LAVAGGIO	SECOND WASH	2°LAVAGE
W1	1°LAVAGGIO	FIRST WASH	1°LAVAGE
RR	RISCIACQUO POT.	POWER RINSE	RINÇAGE PLUS
CP	PANNELLO COM.	CONTROL PANELL	PANNEAU DE CONTRÔLE
D	ASCIUGATURA	DRYER	SECHAGE



ITEM / ID	CODICE / P-code	DESCRIPTION (EN)	Q.TA'/Q.TY
1	DW12023	1/2" HOSE HOLDER Ø 12/20	1
2	DW12039	M 1/2" HOSE HOLDER Ø 10	1
3	DW3002140	TAP	1
4	DW3071196	INOX PIPE FITTING 1/2" M/M	1
5	DW3071258	SOLENOID VALVE 1/2" 24V 60Hz ("UL")	2
6	DW3071205	INOX PIPE FITTING 3/4"M - 1/2" M	2
7	DW3071193	INOX PIPE FITTING 3/4"M/F	1
8	DW3070346	SOLENOID VALVE SUPPORT	1
9	DW3071197	INOX PIPE FITTING 3/4"M/M	1
10	DW3009673	RONDELLA Ø42	1
11	DW13326	GASKET Ø 38x27x2	1
12	DW2000121	FILTER	1
13	DW3071217	INOX PIPE FITTING 3/4"F-F-F	1
14	DW2000364	PRESSURE REDUCTION VALVE	1

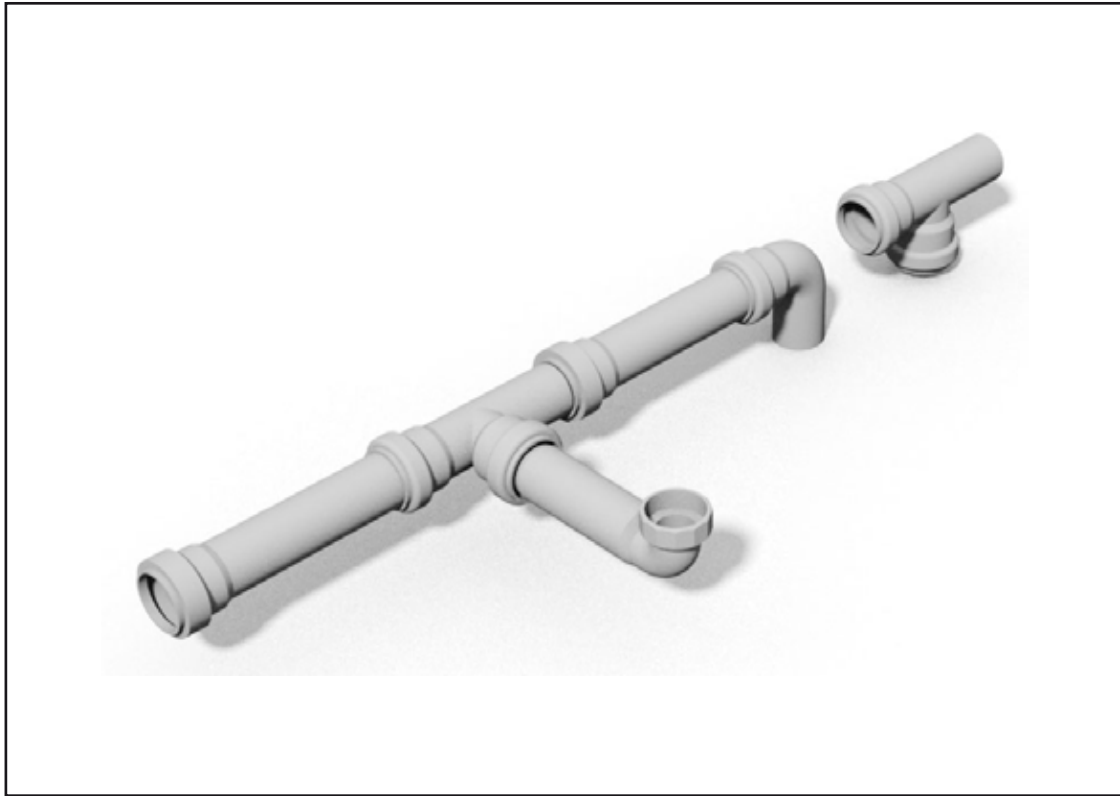

DRAINAGE ASSEMBLIES

ITEM / ID	(IT)	(EN)	(FR)
SG	PARASPRUZZI	SPLASH ZONE	SAS
AS	PREL.AUTOMATICO	PRE-WASH SHOWER	PRELAVAGE AUT.+TIROR
PW	PRELAVAGGIO	PRE-WASH	PRELAVAGE
W2	2°LAVAGGIO	SECOND WASH	2°LAVAGE
W1	1°LAVAGGIO	FIRST WASH	1°LAVAGE
RR	RISCIACQUO POT.	POWER RINSE	RINÇAGE PLUS
CP	PANNELLO COM.	CONTROL PANELL	PANNEAU DE CONTRÔLE
D	ASCIUGATURA	DRYER	SECHAGE

DWG-XXXX
Rev.00 - 05/2017

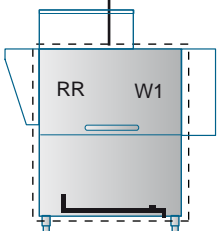
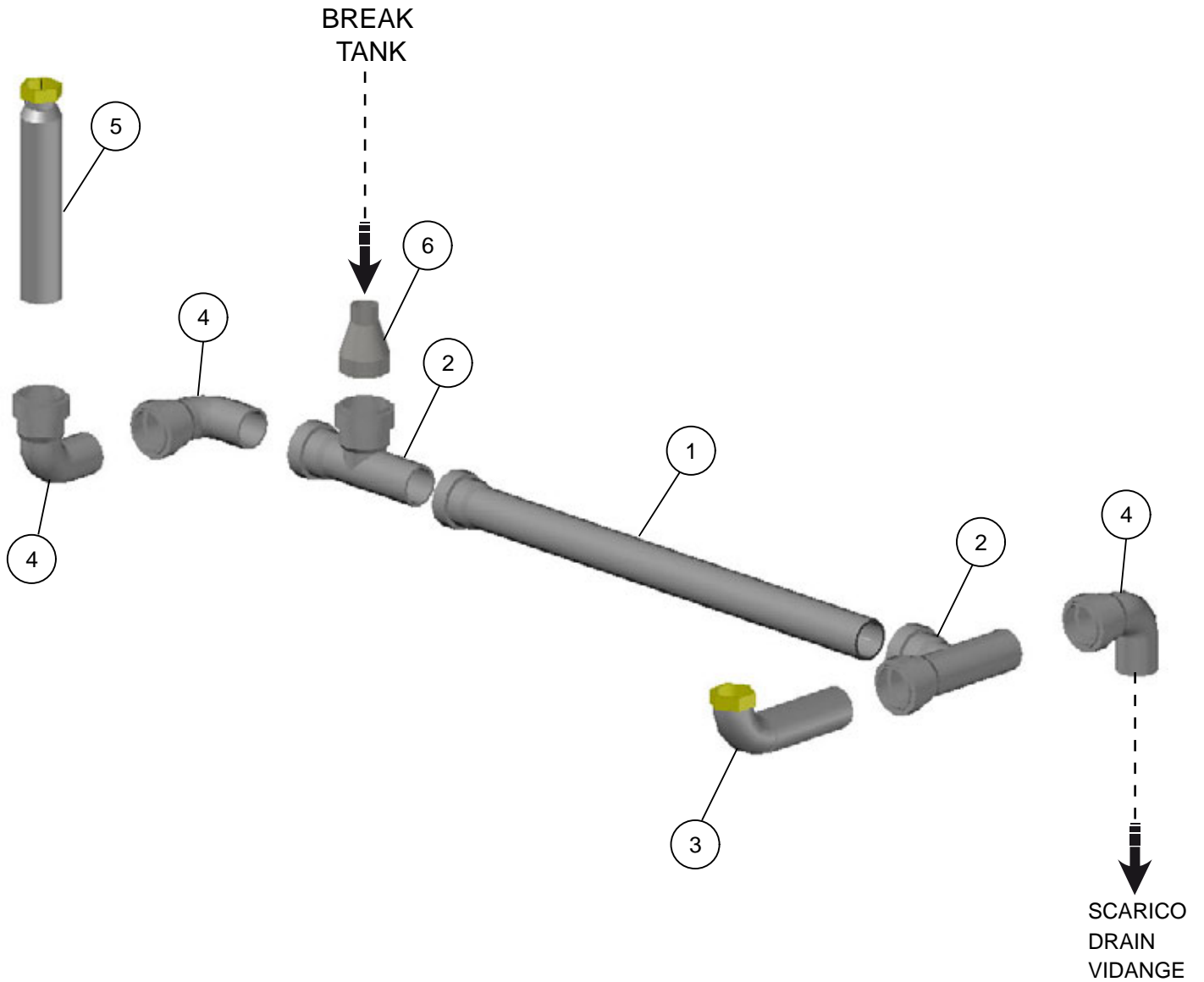



ITEM / ID	CODICE / P-code	DESCRIPTION (EN)	Q.TA'/Q.TY
1	DW3060250	Ø 40 HOSE	1
2	DW3060176	T JUNCTION PP FF M Ø40	2
3	DW3060174	CURVED HOSE WITH BRASS NUT Ø40x1"1/4	1
4	DW3060175	90° ELBOW Ø40 PP	3
5	DW3060173	STRAIGHT HOSE WITH BRASS NUT Ø40x 1/14"	1
6	DW3060249	REDUCTION PIECE Ø40/32	1

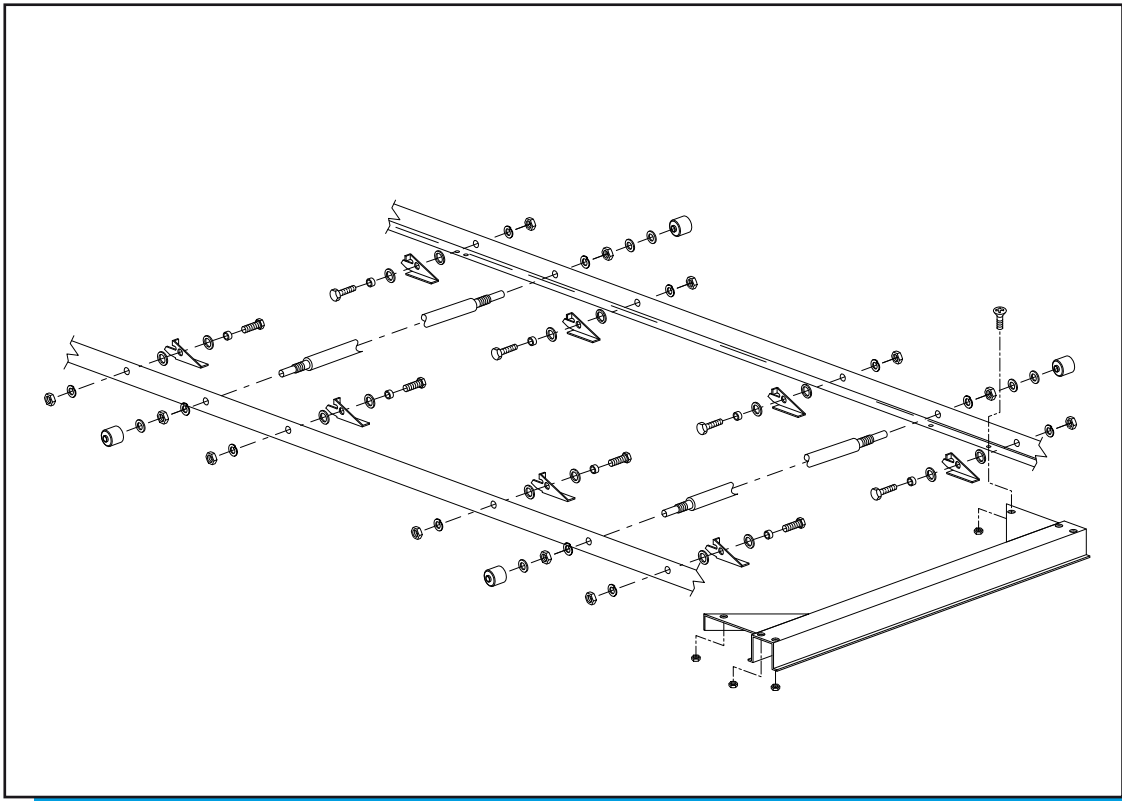

CONVEYOR PARTS

ITEM / ID	(IT)	(EN)	(FR)
SG	PARASPRUZZI	SPLASH ZONE	SAS
AS	PREL.AUTOMATICO	PRE-WASH SHOWER	PRELAVAGE AUT.+TIROR
PW	PRELAVAGGIO	PRE-WASH	PRELAVAGE
W2	2°LAVAGGIO	SECOND WASH	2°LAVAGE
W1	1°LAVAGGIO	FIRST WASH	1°LAVAGE
RR	RISCIACQUO POT.	POWER RINSE	RINÇAGE PLUS
CP	PANNELLO COM.	CONTROL PANELL	PANNEAU DE CONTROLE
D	ASCIUGATURA	DRYER	SECHAGE

Rev.00 - 05/2017

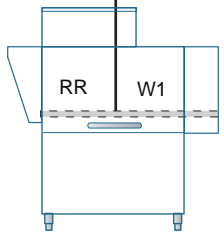
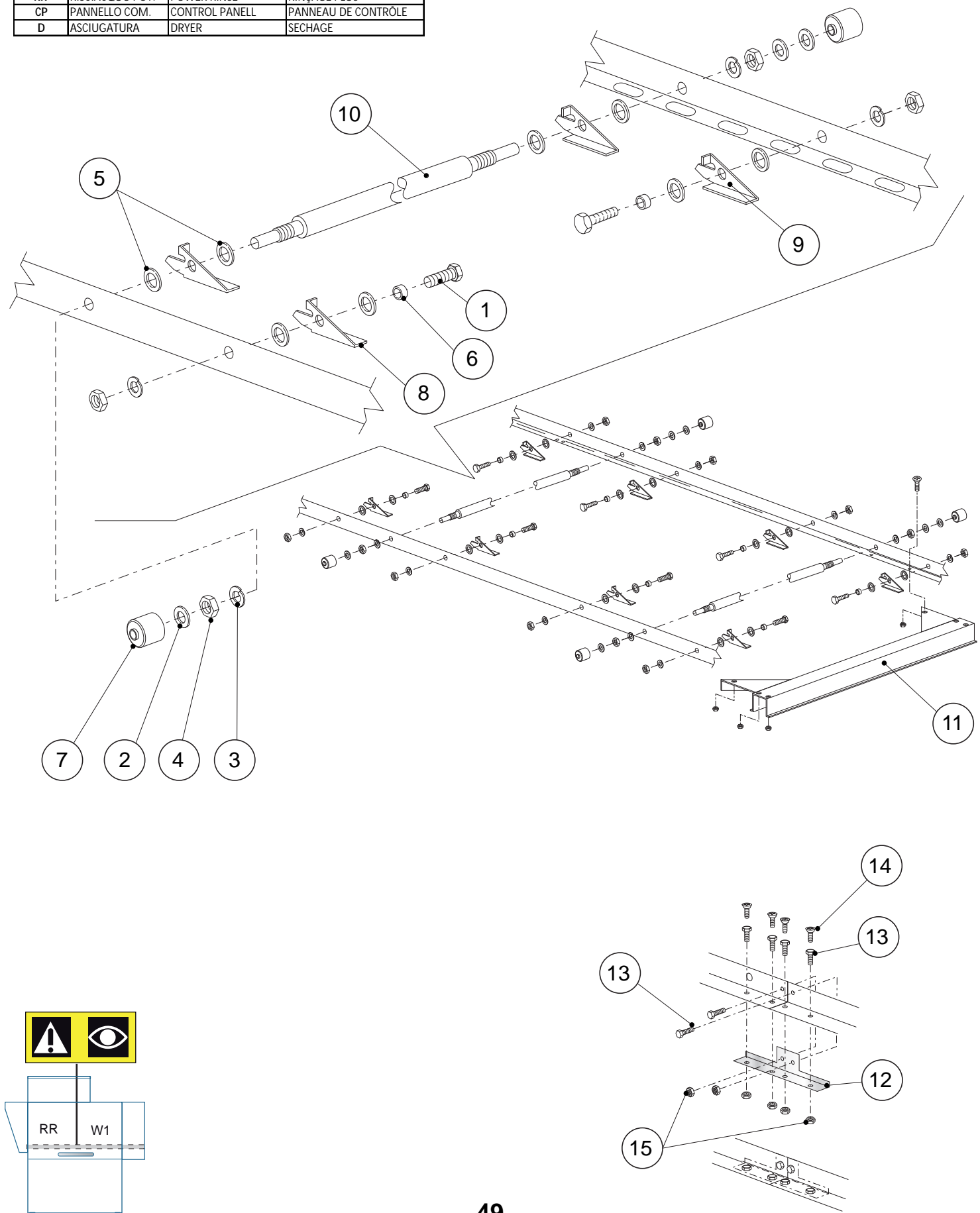



ITEM / ID	CODICE / P-code	DESCRIPTION (EN)	Q.TA'/Q.TY
1	DW11109	SCREW	X
2	DW11185	WASHER	X
3	DW11609	SPLIT WASHER	X
4	DW11719	NUT	X
5	DW3003024	WASHER	X
6	DW3003025	BUSH	X
7	DW3003026	BUSH	X
8	DW3003100	CLIP RIGHT	X
9	DW3003101	CLIP LEFT	X
10	DW3003010	AXIS	X
11	DW3009107	GUIDE	X
12	DW3009168	INOX PLATE COVERING	X
13	DW11118	INOX SCREW M6x12 TE 933	X
14	DW11117	INOX SCREW M6x12	X
15	DW11721	INOX NUT M6 AUT. UNI 7473 DIN 982	X

ITEM / ID	(IT)	(EN)	(FR)
SG	PARASPRUZZI	SPLASH ZONE	SAS
AS	PREL.AUTOMATICO	PRE-WASH SHOWER	PRELAVAGE AUT.+TIROR
PW	PRELAVAGGIO	PRE-WASH	PRELAVAGE
W2	2°LAVAGGIO	SECOND WASH	2°LAVAGE
W1	1°LAVAGGIO	FIRST WASH	1°LAVAGE
RR	RISCIACQUO POT.	POWER RINSE	RINÇAGE PLUS
CP	PANNELLO COM.	CONTROL PANELL	PANNEAU DE CONTRÔLE
D	ASCIUGATURA	DRYER	SECHAGE

Rev.00 - 05/2017

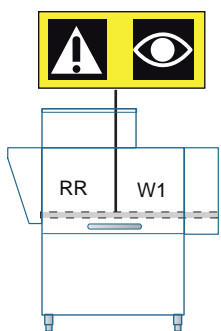
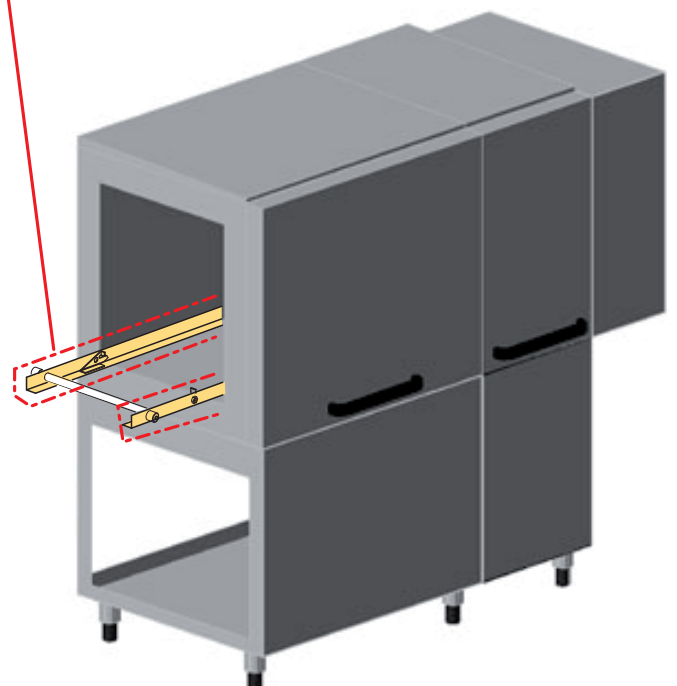
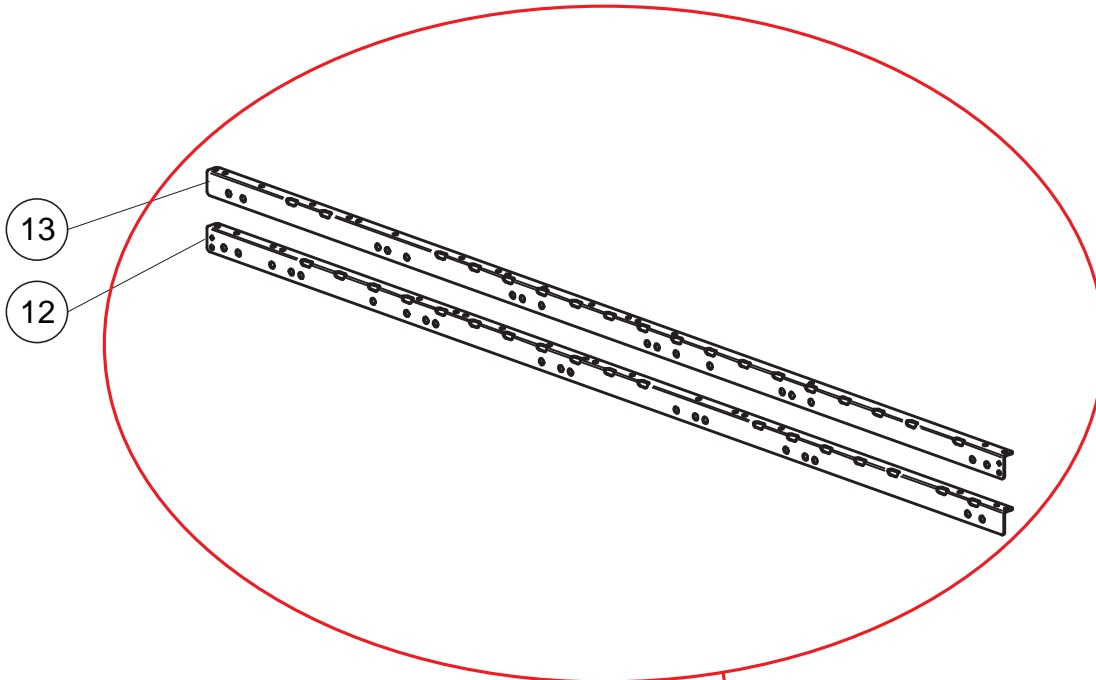



ITEM / ID	CODICE / P-code	DESCRIPTION (EN)	Q.TA'/Q.TY
12	DW3070106	LEFT CARRIAGE L=1390mm	x
13	DW3070105	RIGHT CARRIAGE L=1390mm	x

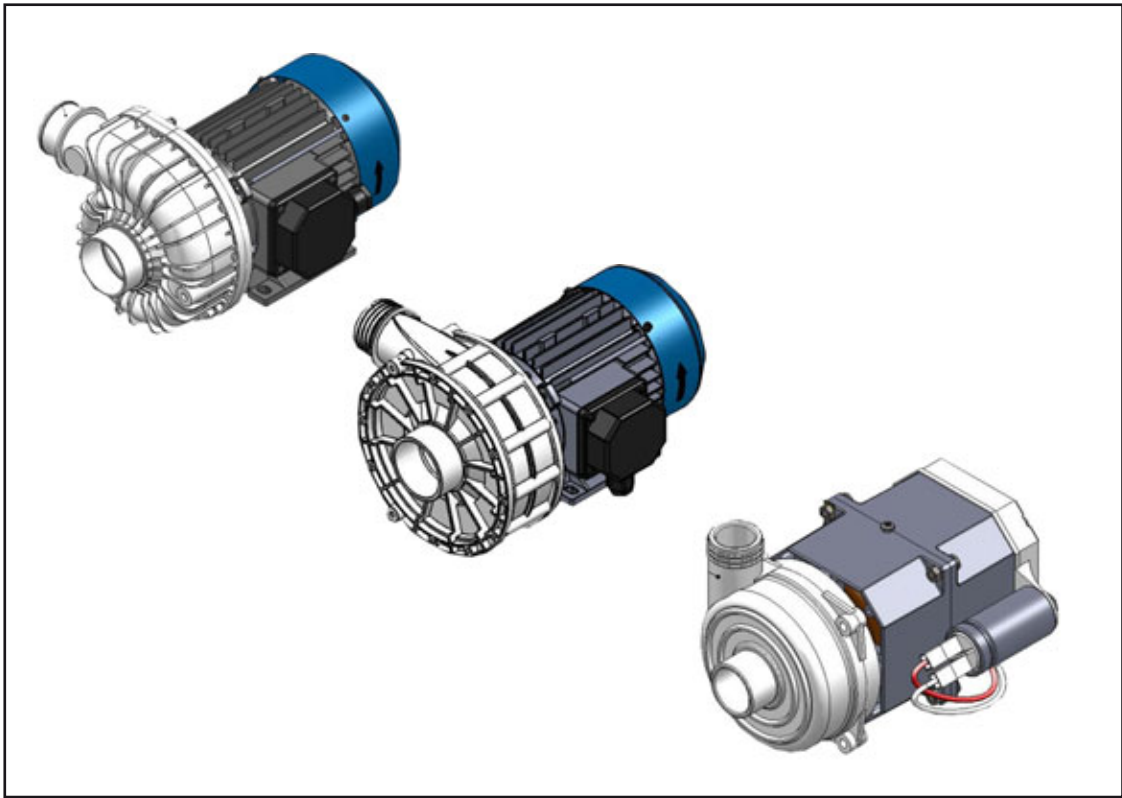

———— PUMP

ITEM / ID	(IT)	(EN)	(FR)
SG	PARASPRUZZI	SPLASH ZONE	SAS
AS	PREL.AUTOMATICO	PRE-WASH SHOWER	PRELAVAGE AUT.+TIROR
PW	PRELAVAGGIO	PRE-WASH	PRÉLAVAGE
W2	2°LAVAGGIO	SECOND WASH	2°LAVAGE
W1	1°LAVAGGIO	FIRST WASH	1°LAVAGE
RR	DOPIO RISCIAQ.	DOUBLE RINSE	DOUBLE RINÇAGE
CP	PANNELLO COM.	CONTROL PANELL	PANNEAU DE CONTRÔLE
D	ASCIUGATURA	DRYER	SECHAGE

DWG-5xxxx
Rev.00 - 05/2017

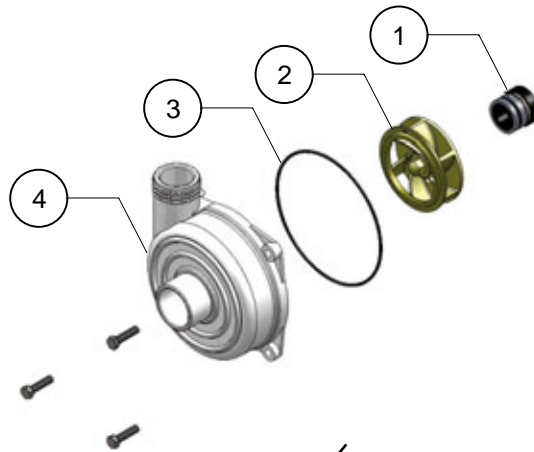

PRE-RINSING PUM (RR)
Model:DW3071096/U
Type: RC64/RC86

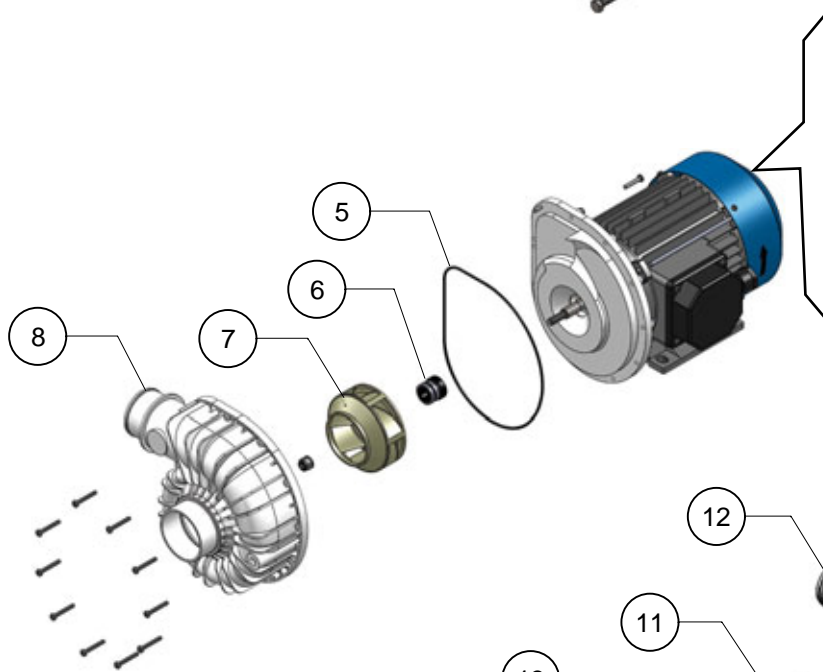

WASHING PUM (W1)
PRE-WASHING PUMP (PW)
Model:DW3000082/U
Type: RC62/RC86

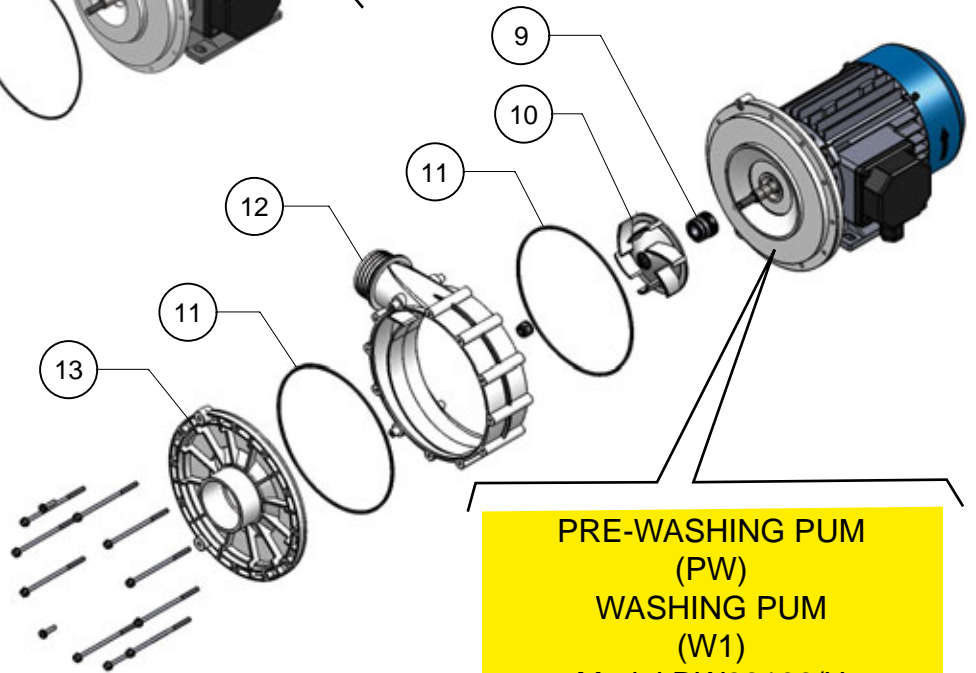

PRE-WASHING PUM (PW)
WASHING PUM (W1)
Model:DW88106/U
Type: RC86/RC64/RC62/RC44

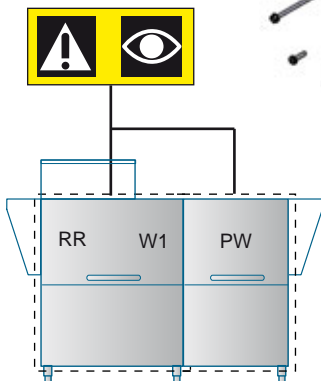
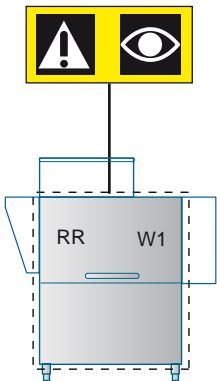



ITEM / ID	CODICE / P-code	DESCRIZIONE (EN)	Q.TA'/Q.TY
1	DW15100/S	ROTATING SEALS	1
2	DW3071096/B	PUMP ROTOR	1
3	DW18245	GASKET	1
4	DW3071096/A	SCROLL	1
5	DW88131	GASKET	1
6	DW15080/F	ROTATING SEALS	1
7	DW88232	PUMP ROTOR	1
8	DW88230	SCROLL	1
9	DW15080/F	ROTATING SEALS	1
10	DW3000082/C	PUMP ROTOR	1
11	DW88231	GASKET	2
12	DW3000082/B	SCROLL	1
13	DW3000082/A	COVER SCROLL	1

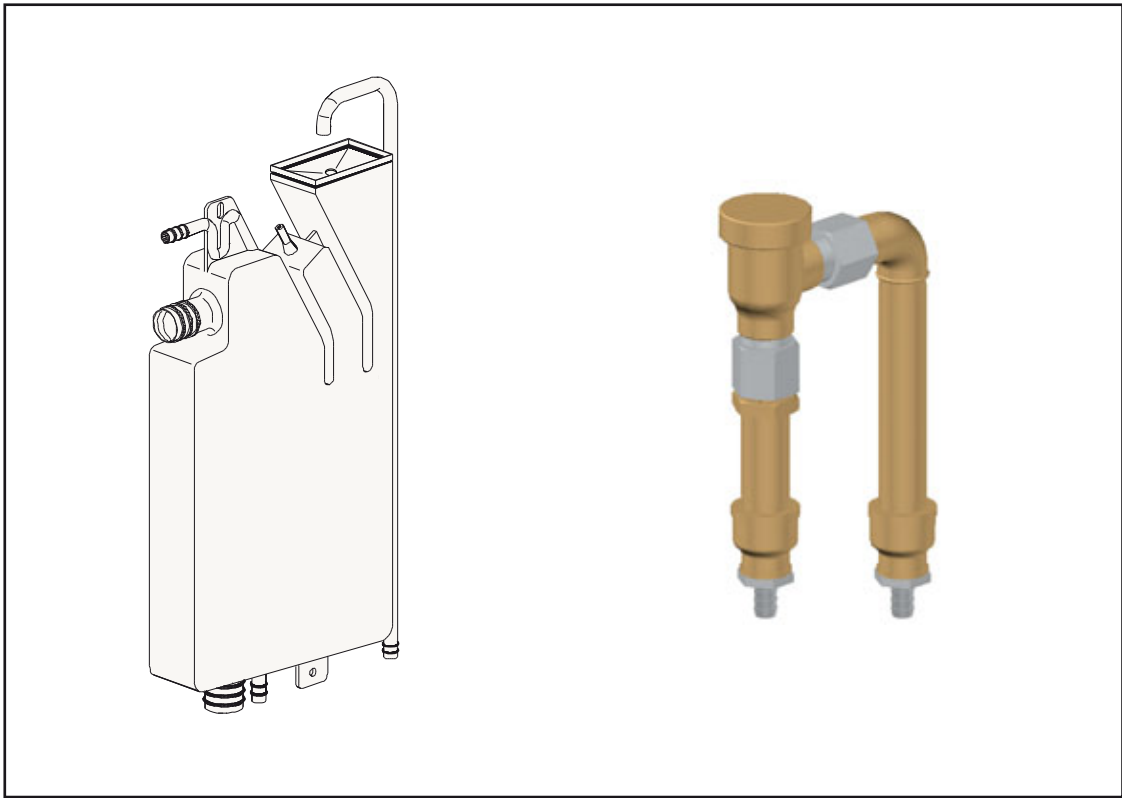

 — **BREAK TANK & VACUUM BREAKER**

ITEM / ID	(IT)	(EN)	(FR)
SG	PARASPRUZZI	SPLASH ZONE	SAS
AS	PREL.AUTOMATICO	PRE-WASH SHOWER	PRELAVAGE AUT.+TIROR
PW	PRELAVAGGIO	PRE-WASH	PRELAVAGE
W2	2°LAVAGGIO	SECOND WASH	2°LAVAGE
W1	1°LAVAGGIO	FIRST WASH	1°LAVAGE
RR	RISCIACQUO POT.	POWER RINSE	RINÇAGE PLUS
CP	PANNELLO COM.	CONTROL PANELL	PANNEAU DE CONTRÔLE
D	ASCIUGATURA	DRYER	SECHAGE

06_XXXX
Rev.00 - 05/2017

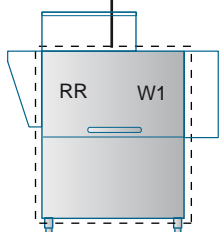
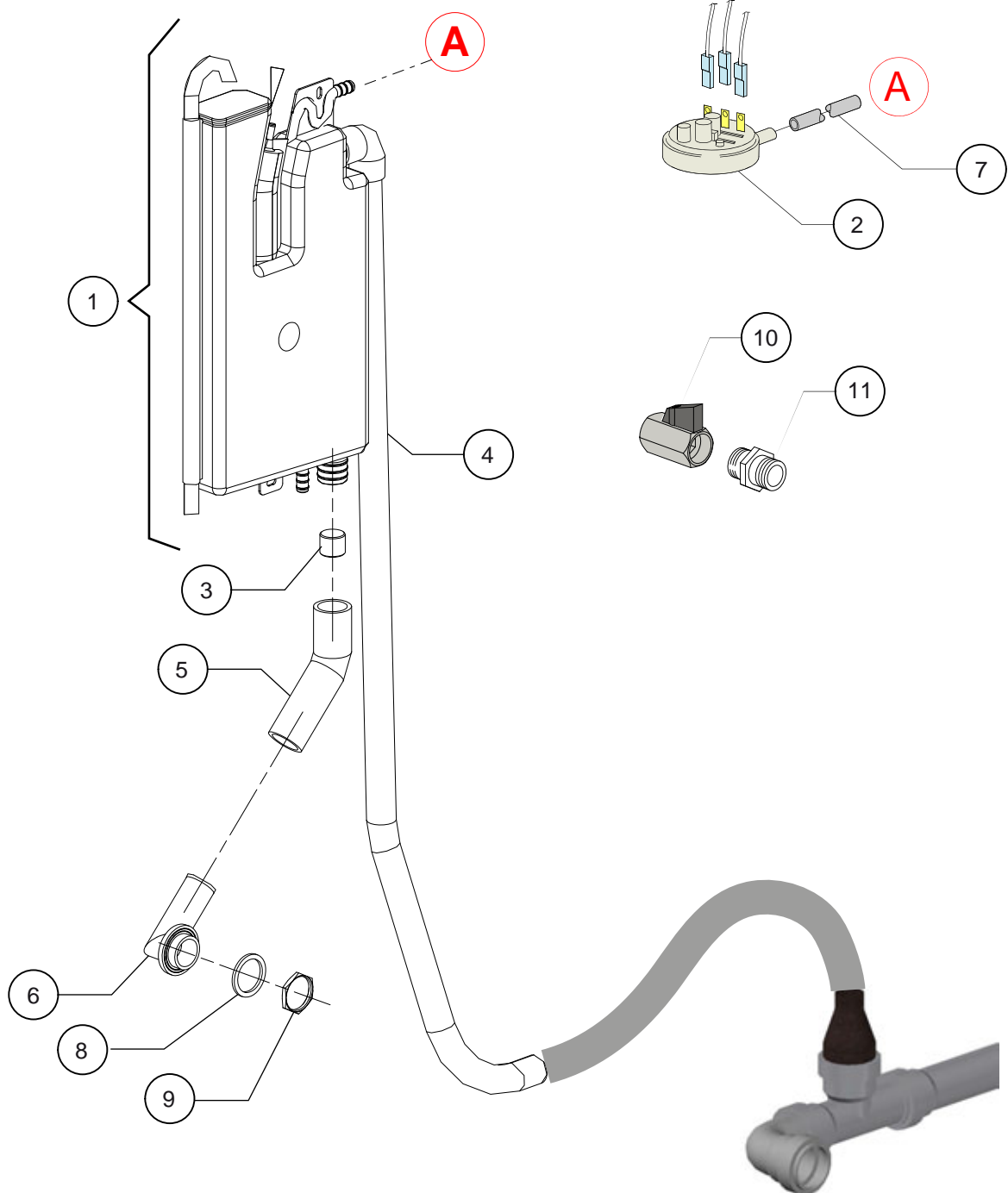



ITEM / ID	CODICE / P-code	DESCRIPTION (EN)	Q.TA'/Q.TY
1	DW15735	BREAK TANK ASSEMBLY (2,4 lt)	1
2	DW3071257	PRESSURE SWITCH ("UL) 47-28	1
3	DW12533	REINFORCE FOR PIPE IN EXIT	1
4	DW25031	BT PIPE ("UL")	1
5	DW18044	Ø 28 RUBBER HOLDER	1
6	DW10701	DRAIN PIPE	1
7	DW14508	EPDM Ø 4,5x9 RUBBER HOLDER	1
8	DW13305	GASKET Ø 44x33x3	1
9	DW11701/A	INOX NUT	1
10	DW3002140	Tap	1
11	DW3071196	Inox pipe fitting 1/2" M/M	1



ITEM / ID	(IT)	(EN)	(FR)
SG	PARASPRUZZI	SPLASH ZONE	SAS
AS	PREL.AUTOMATICO	PRE-WASH SHOWER	PRELAVAGE AUT.+TIROR
PW	PRELAVAGGIO	PRE-WASH	PRELAVAGE
W2	2°LAVAGGIO	SECOND WASH	2°LAVAGE
W1	1°LAVAGGIO	FIRST WASH	1°LAVAGE
RR	RISCIACQUO POT.	POWER RINSE	RINÇAGE PLUS
CP	PANNELLO COM.	CONTROL PANELL	PANNEAU DE CONTRÔLE
D	ASCIUGATURA	DRYER	SECHAGE

06_XXXX
Rev.00 - 05/2017

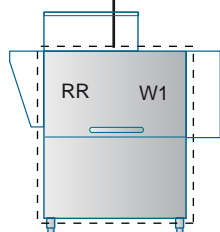
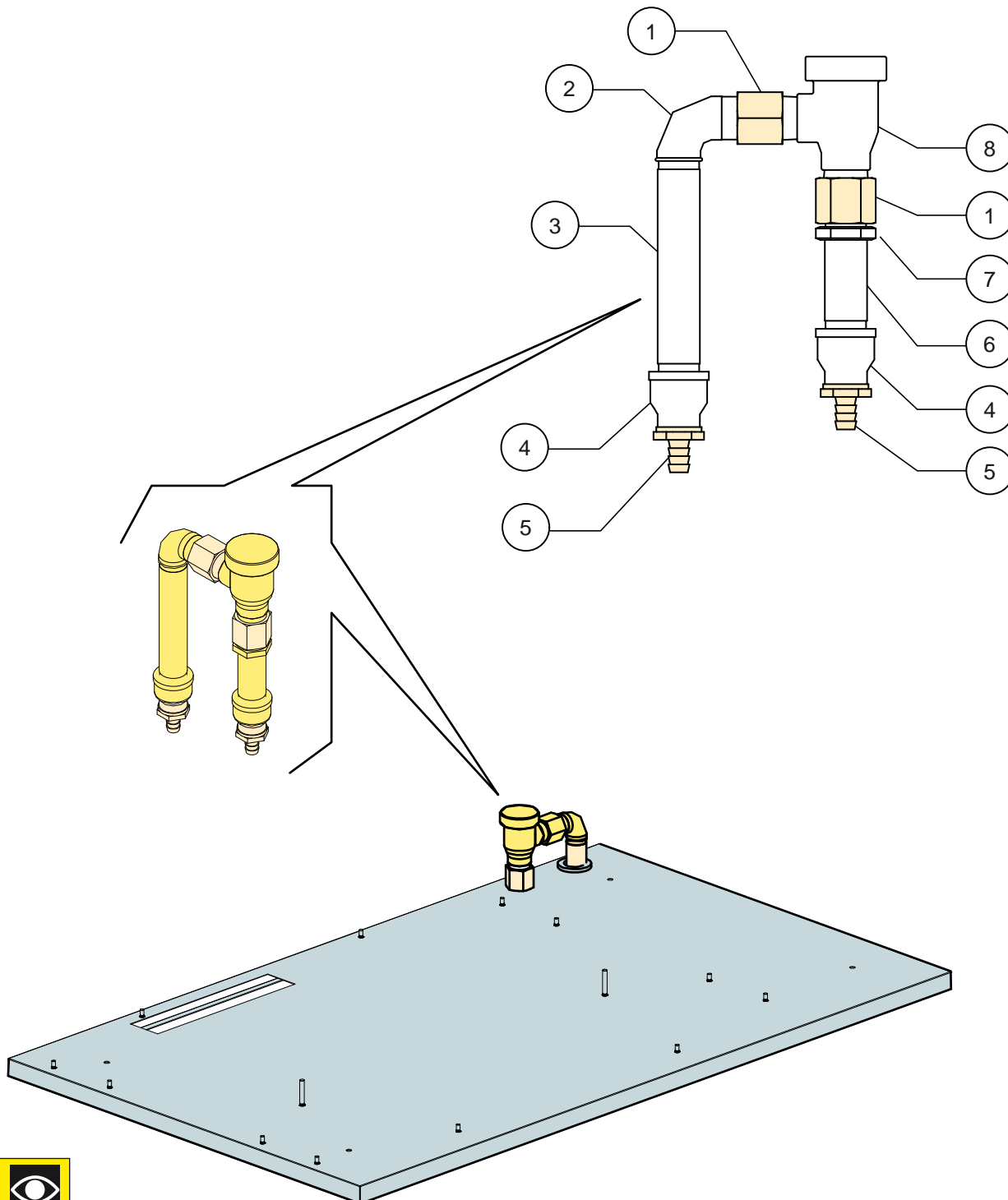



ITEM / ID	CODICE / P-code	DESCRIPTION (EN)	Q.TA'/Q.TY
1	DW3071265	INOX PIPE FITTING M 3/4" NPT x F3/4" BSP	2
2	DW3071193	INOX PIPE FITTING 3/4" M/F	1
3	DW3071213	INOX PIPE FITTING 3/4" M/M	1
4	DW3071218	INOX PIPE FITTING 3/4" - 1/2" F/F	2
5	DW12023	M 1/2" Ø12 HOSE HOLDER	2
6	DW3071211	INOX PIPE FITTING 3/4" M/M	1
7	DW2200103	3/4" NUT 32x8	1
8	DW3071264	1001 F 3/4" NPT 90° VACUUM BREAKER ASSE	1

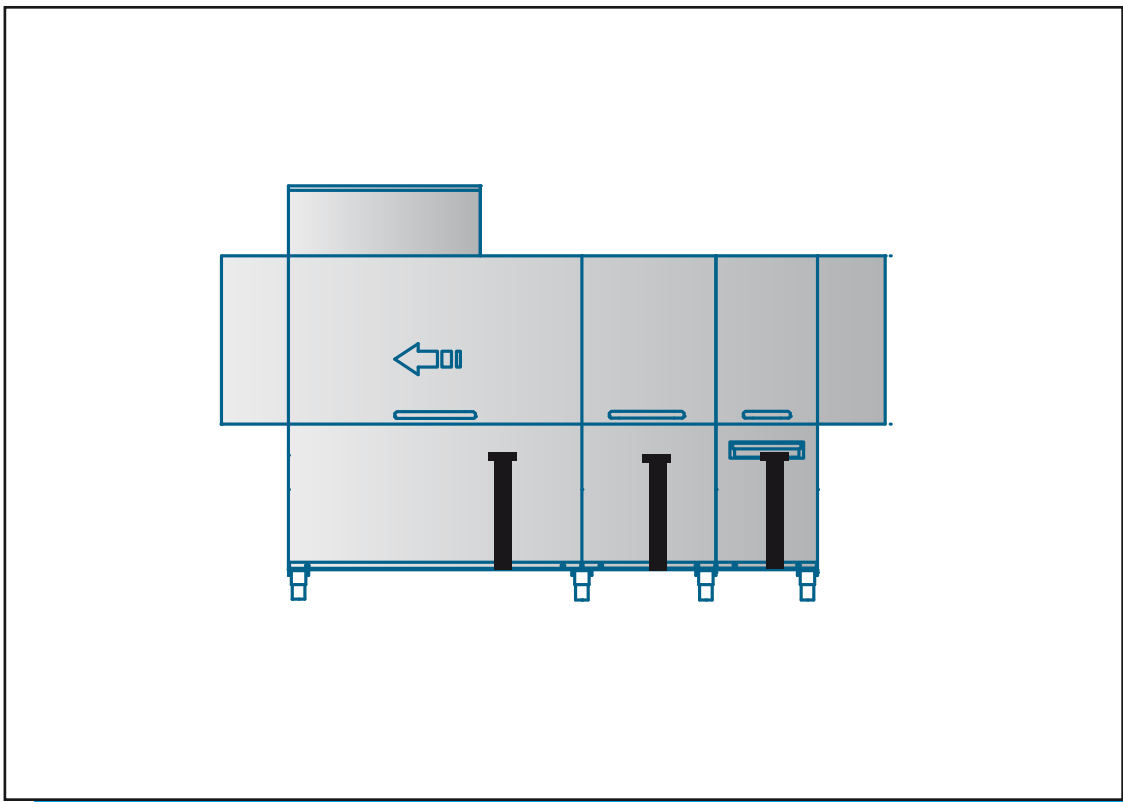

OVER FLOW PIPE



OVER FLOW PIPE WITH MODEL & POSITION

Rev.00 - 05/2017

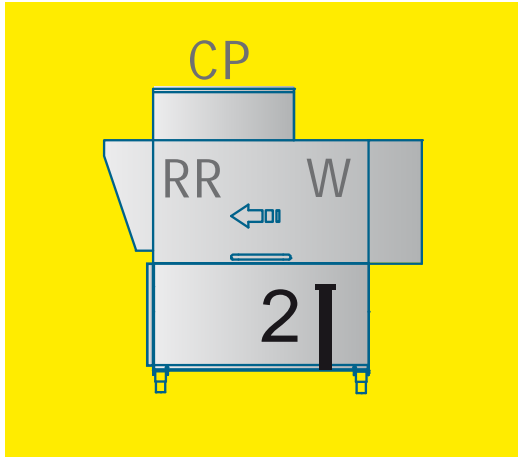

ITEM / ID	CODICE / P-code
2	DW3071182

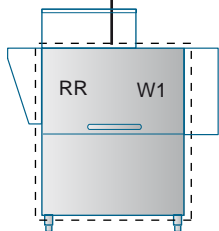
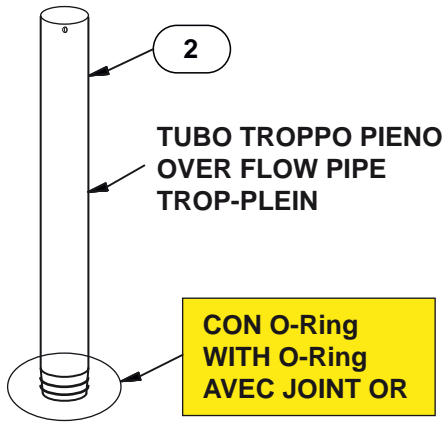

ITEM / ID	(IT)	(EN)	(FR)
SG	PARASPRUZZI	SPLASH ZONE	SAS
AS	PREL.AUTOMATICO	PRE-WASH SHOWER	PRELAVAGE AUT.+TIROR
PW	PRELAVAGGIO	PRE-WASH	PRELAVAGE
W2	2°LAVAGGIO	SECOND WASH	2°LAVAGE
W1	1°LAVAGGIO	FIRST WASH	1°LAVAGE
RR	RISCIACQUO POT.	POWER RINSE	RINÇAGE PLUS
CP	PANNELLO COM.	CONTROL PANELL	PANNEAU DE CONTRÔLE
D	ASCIUGATURA	DRYER	SECHAGE

